



FAMU-FSU
College of
Engineering

Team 502: Boeing Underwater Glider

Jake Burns, Tristan Hardy, Nicolas Lorin
Justin Sepulveda, Martin White

11/12/2024

Team Introductions



Jake Burns
Simulations Engineer

Tristan Hardy
Modeling Engineer

Nicolas Lorin
Controls Engineer

Justin Sepulveda
Systems Engineer

Martin White
Materials Engineer



Sponsor and Advisor



Project Sponsor
Shawn Butler



Project Sponsor
JaQuan Young



Academic Advisor
Shayne McConomy



Faculty Advisor
Kourosh Shoele



Objective

The objective of this project is to simulate and construct an underwater glider.



Functional Decomposition



Targets and Metrics

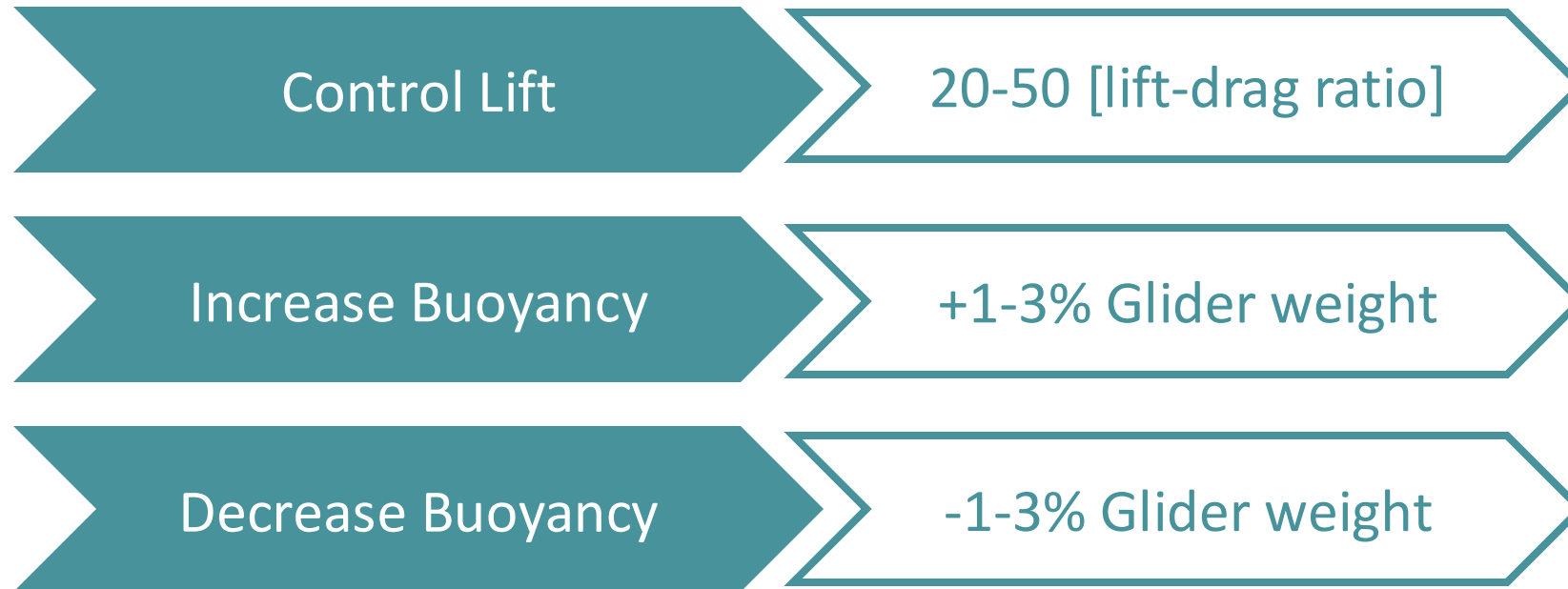

Targets and Metrics

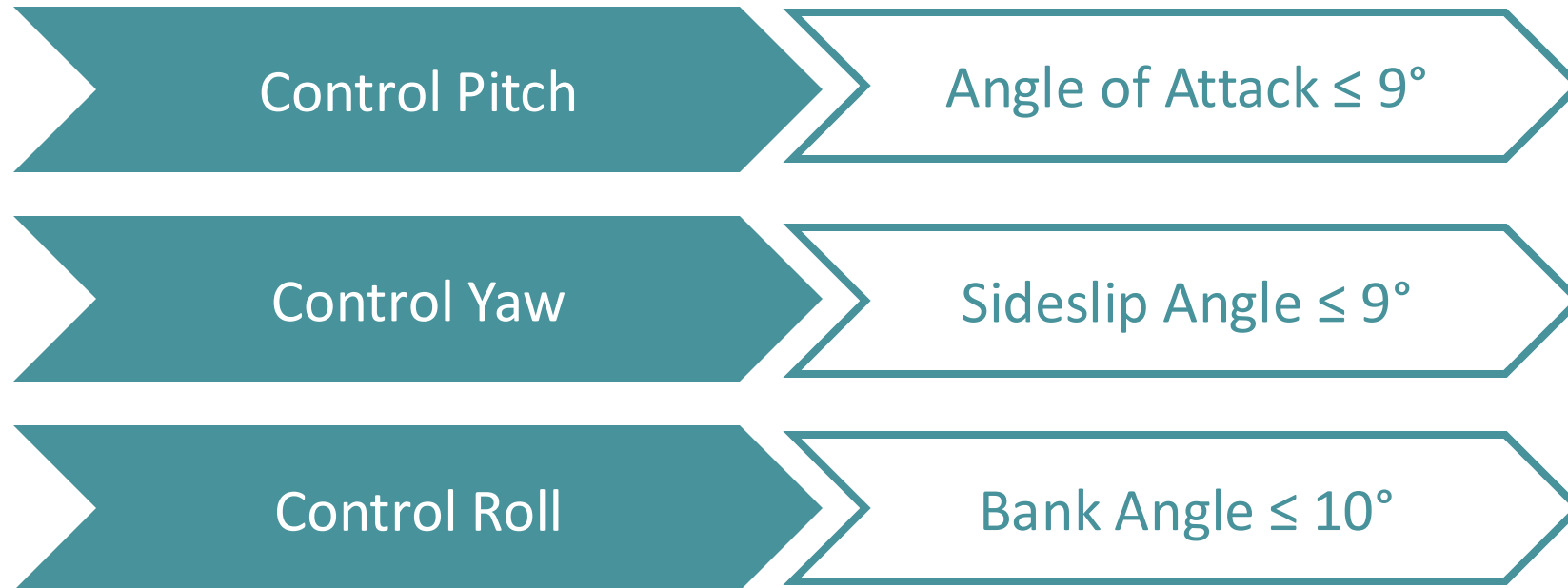

Targets and Metrics

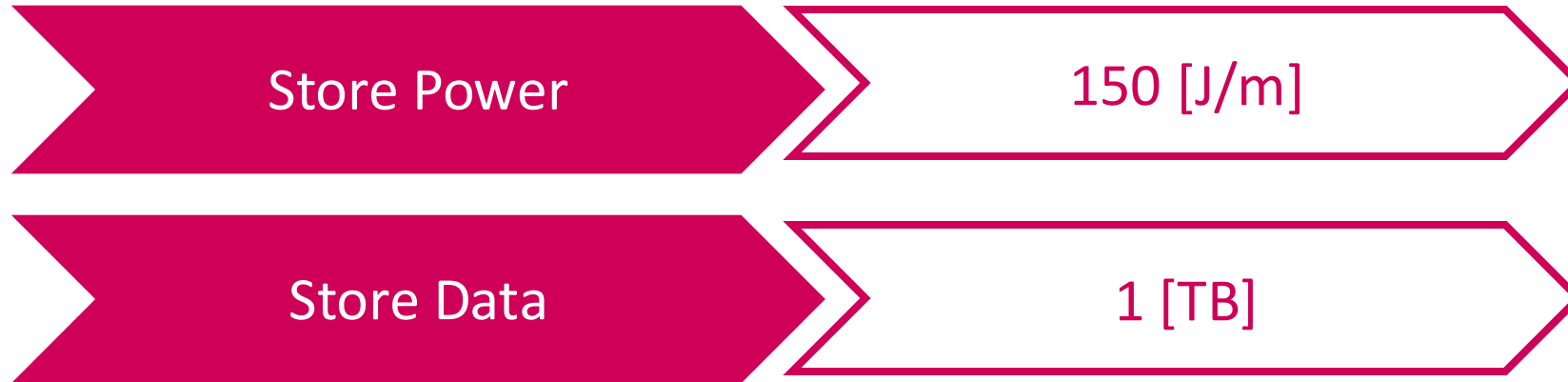

Targets and Metrics

Endure Fatigue Stress

1000 [cycles]

Withstand Pressure
Difference

0.6 [MPa]



Ideation Methodology

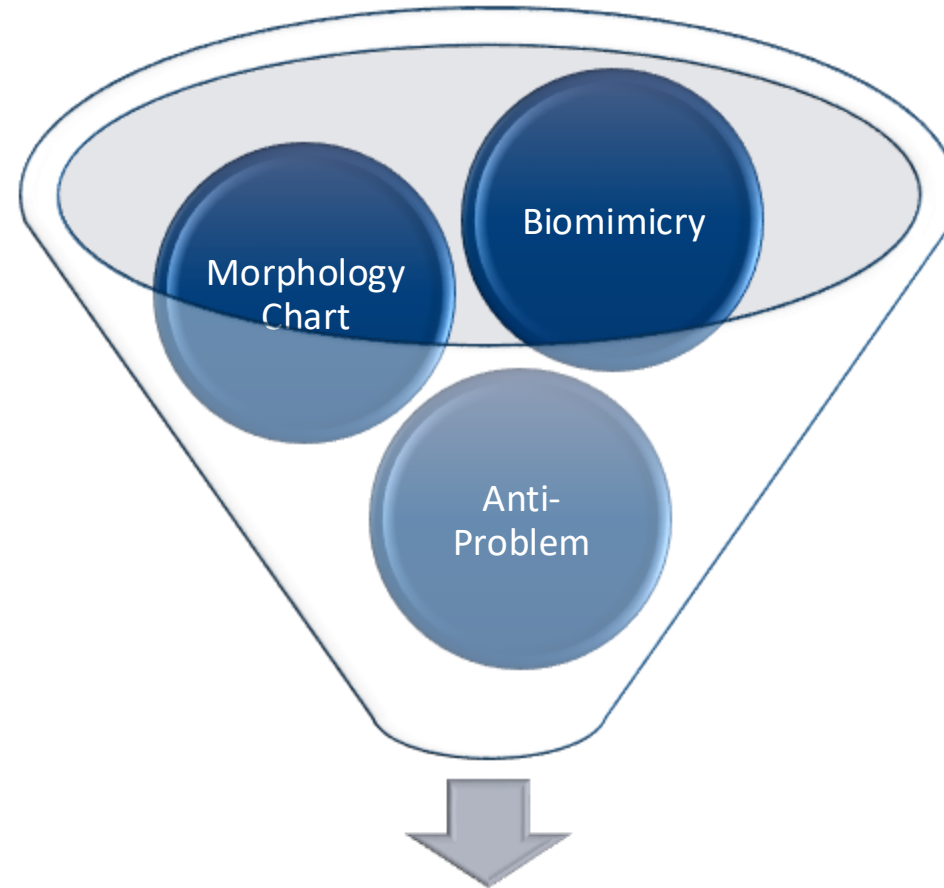

Concept Generation

Medium Fidelity

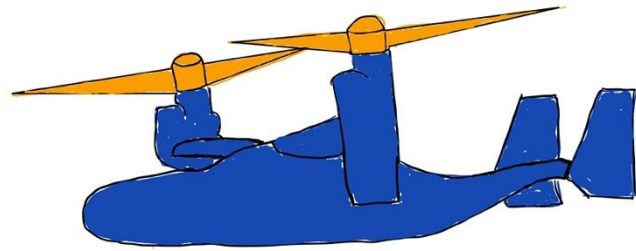

Propeller Glider

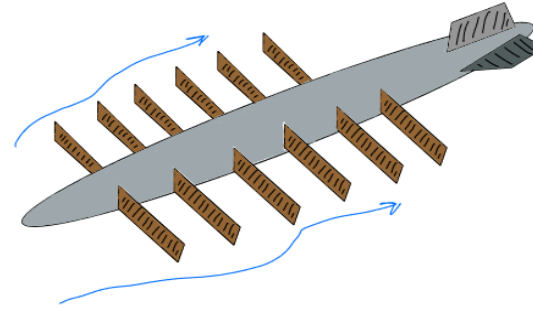

Energy Harvesting Glider

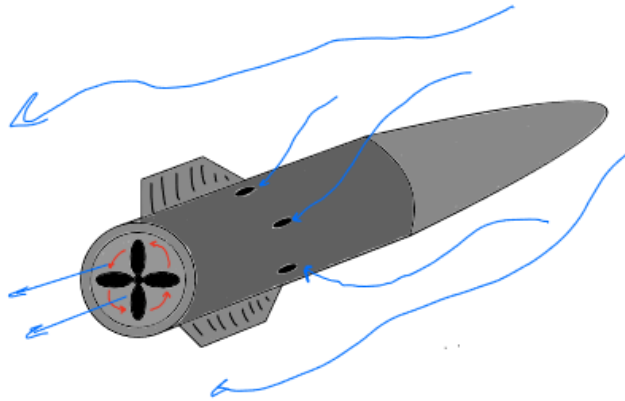

DC Motor Glider

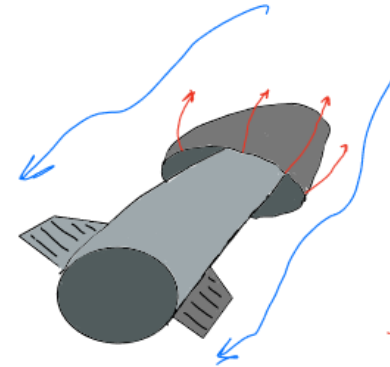

Jellyfish Glider

Dual Hull Glider

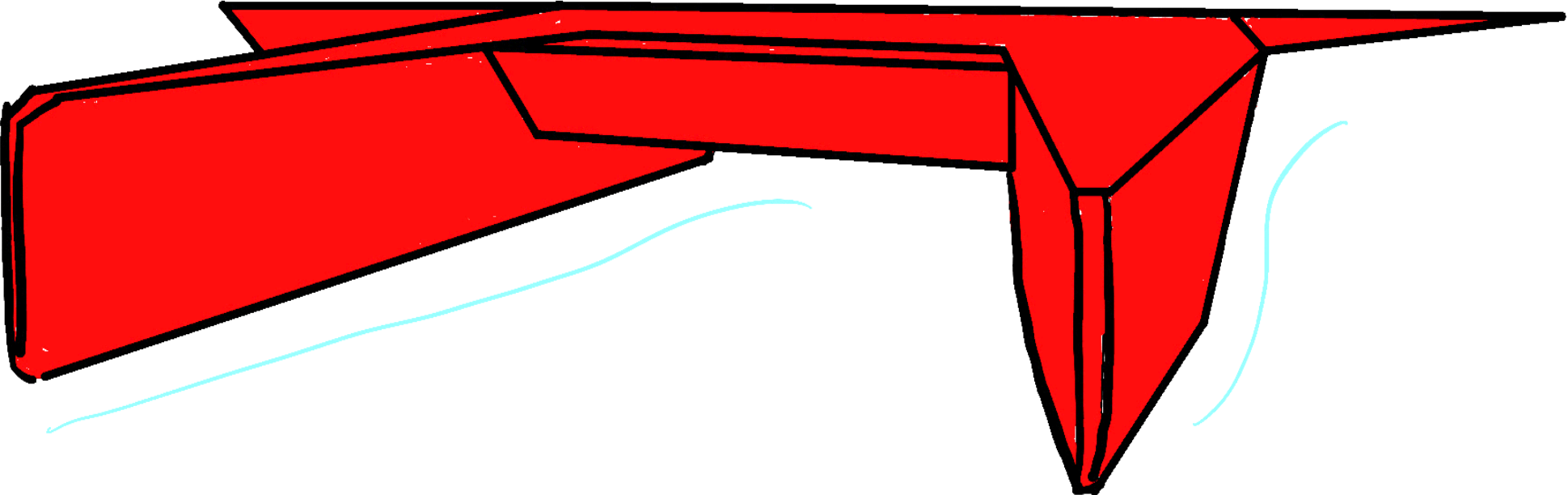

Dual Hull Glider

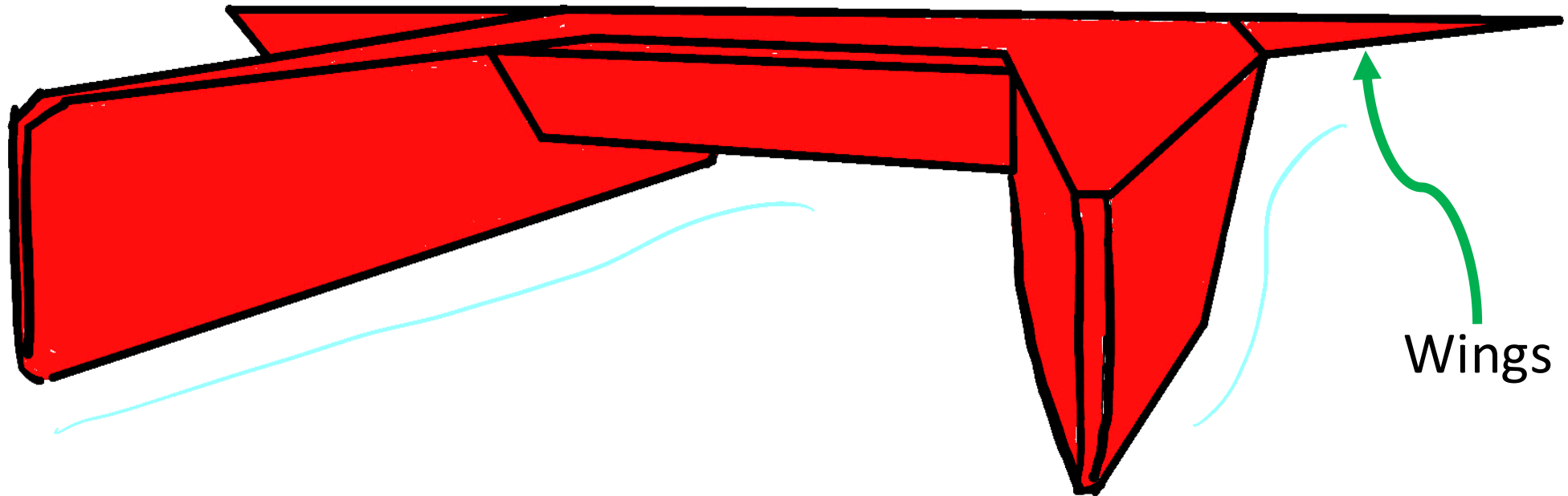

Dual Hull Glider

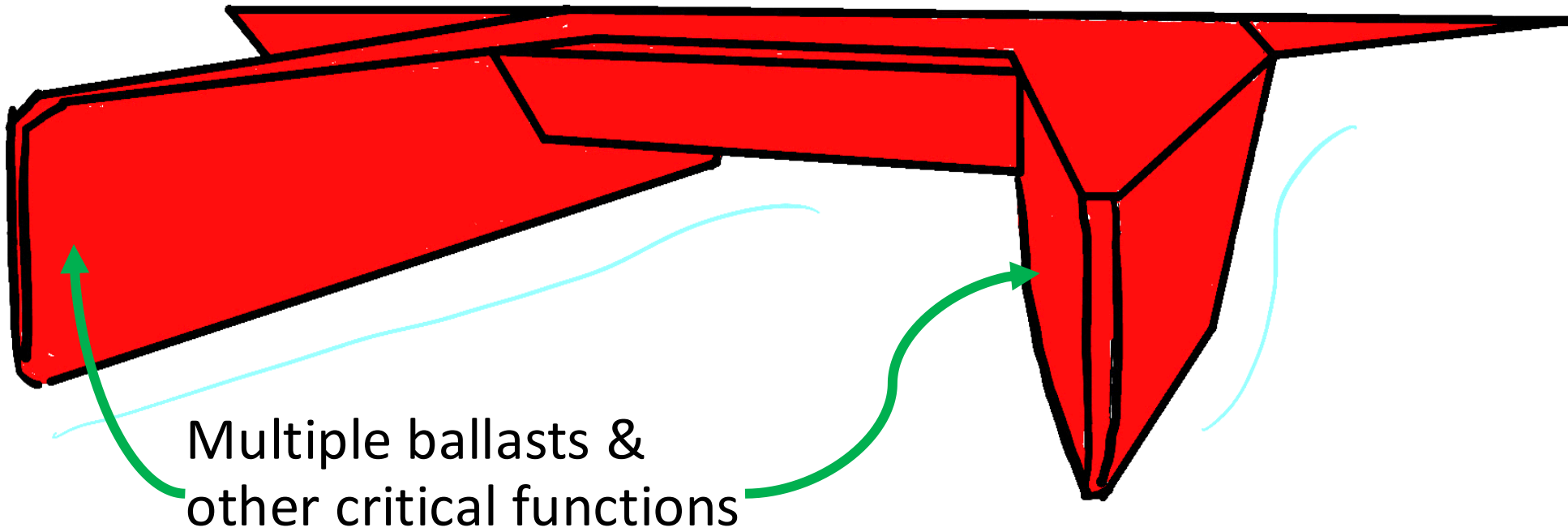

Dual Hull Glider

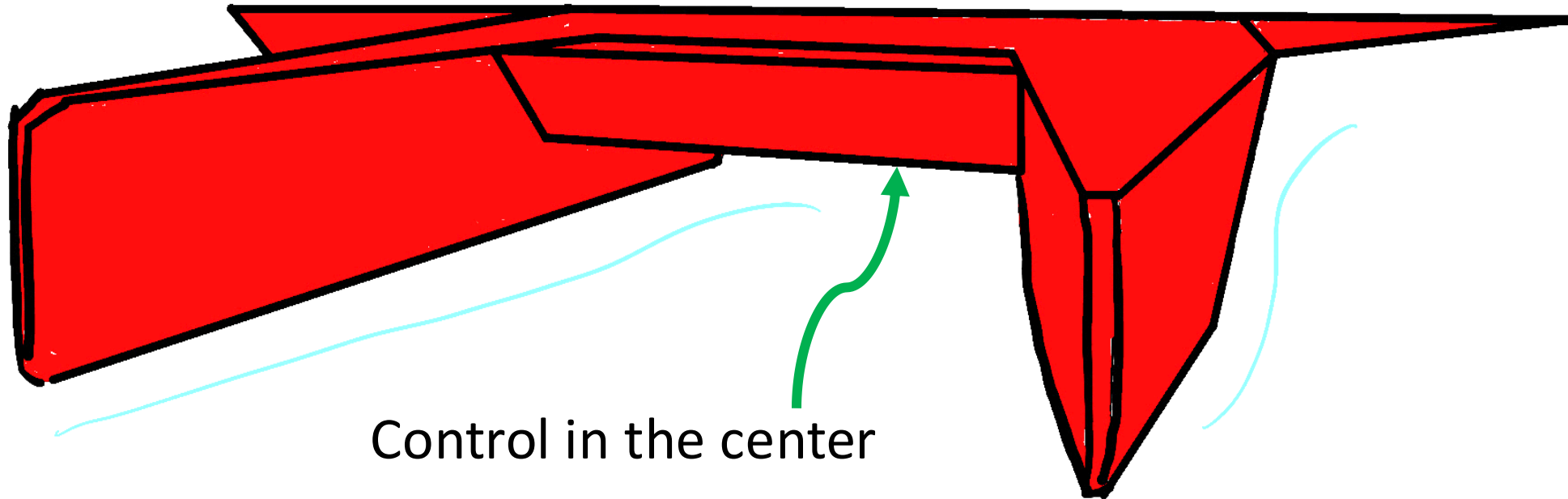

Control in the center

Adjustable Wing Glider

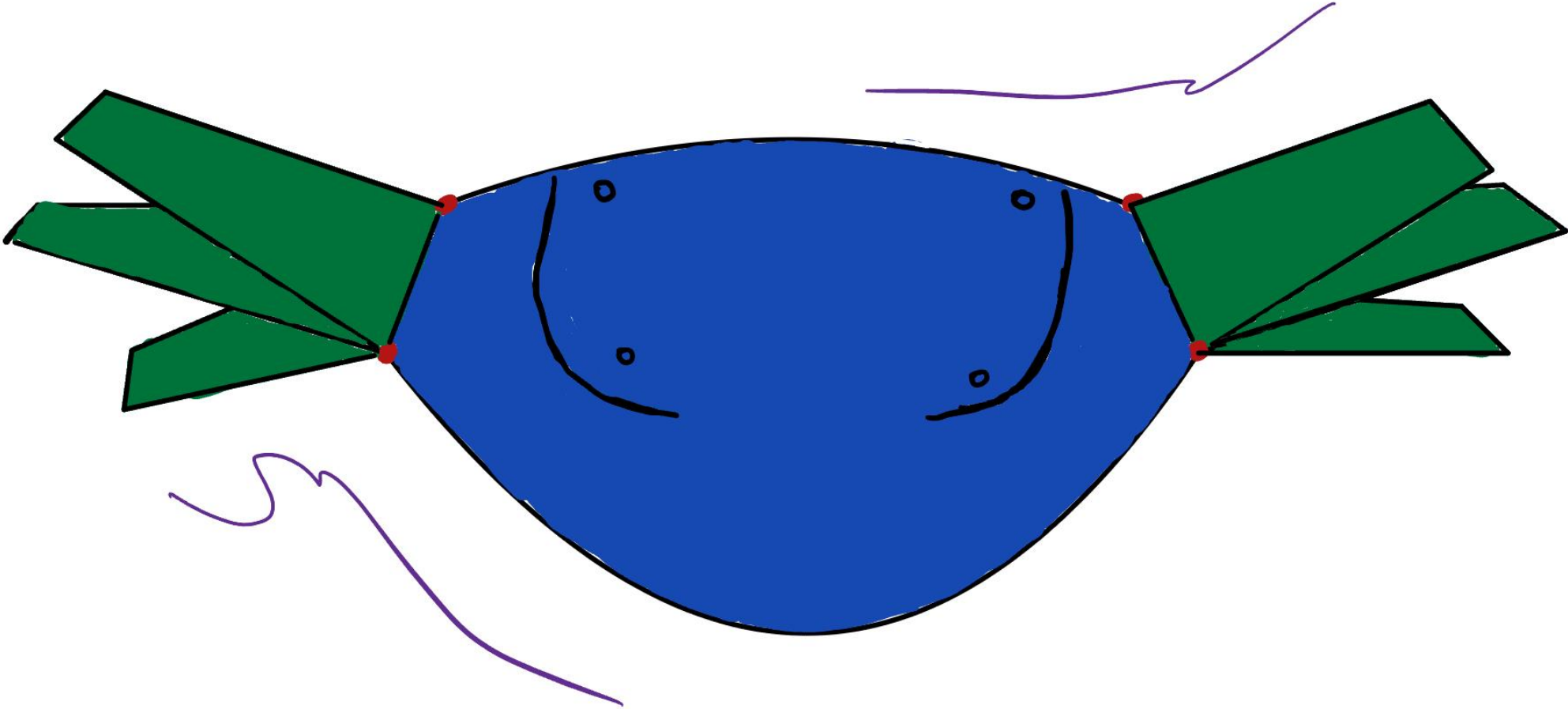

Adjustable Wing Glider

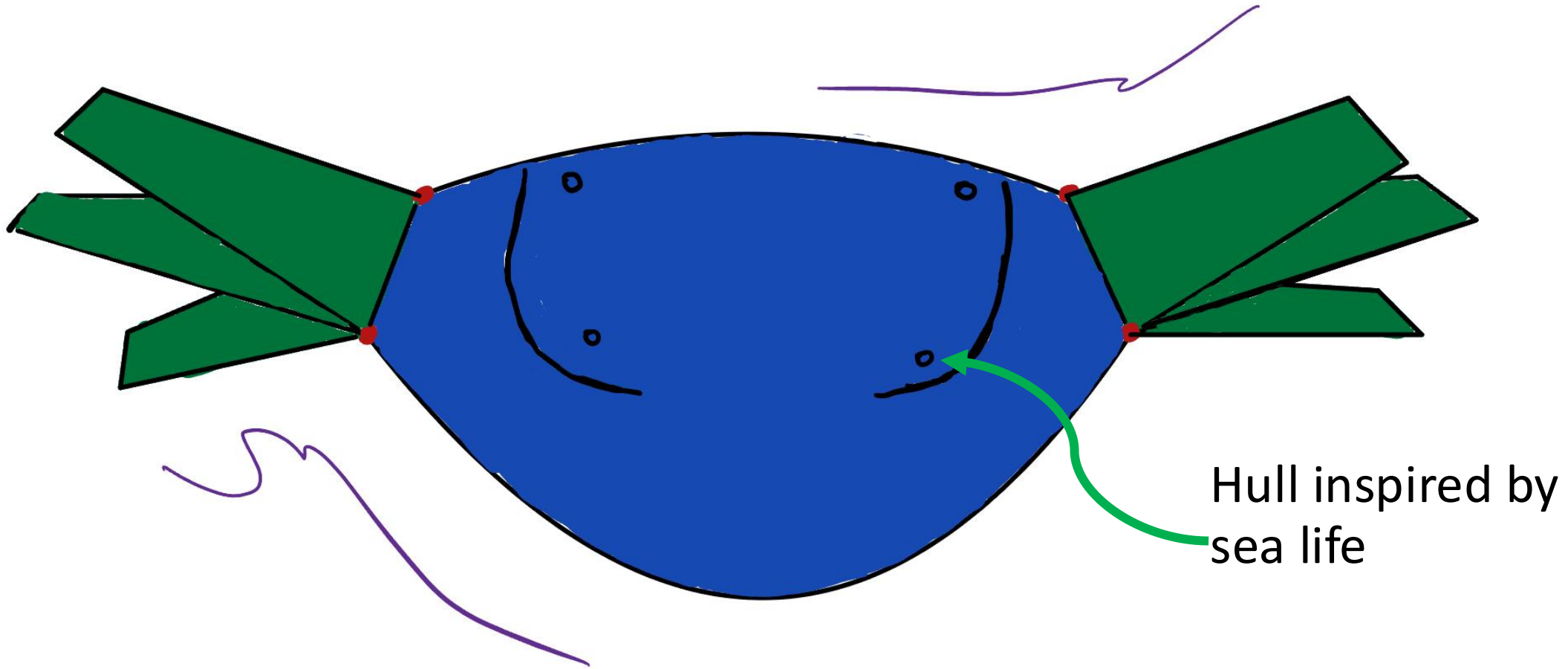

Hull inspired by
sea life

Adjustable Wing Glider

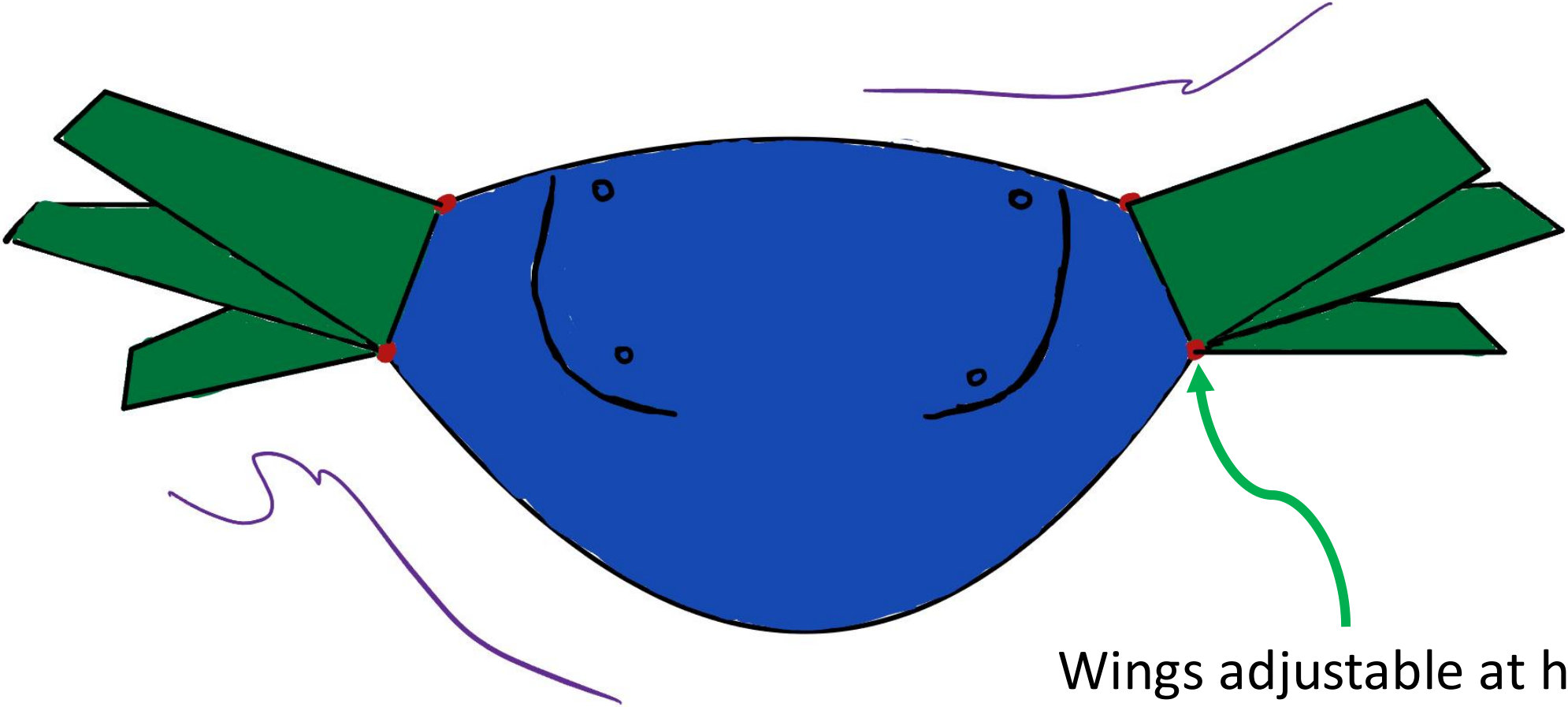

Wings adjustable at hinge



Adjustable Wing Glider

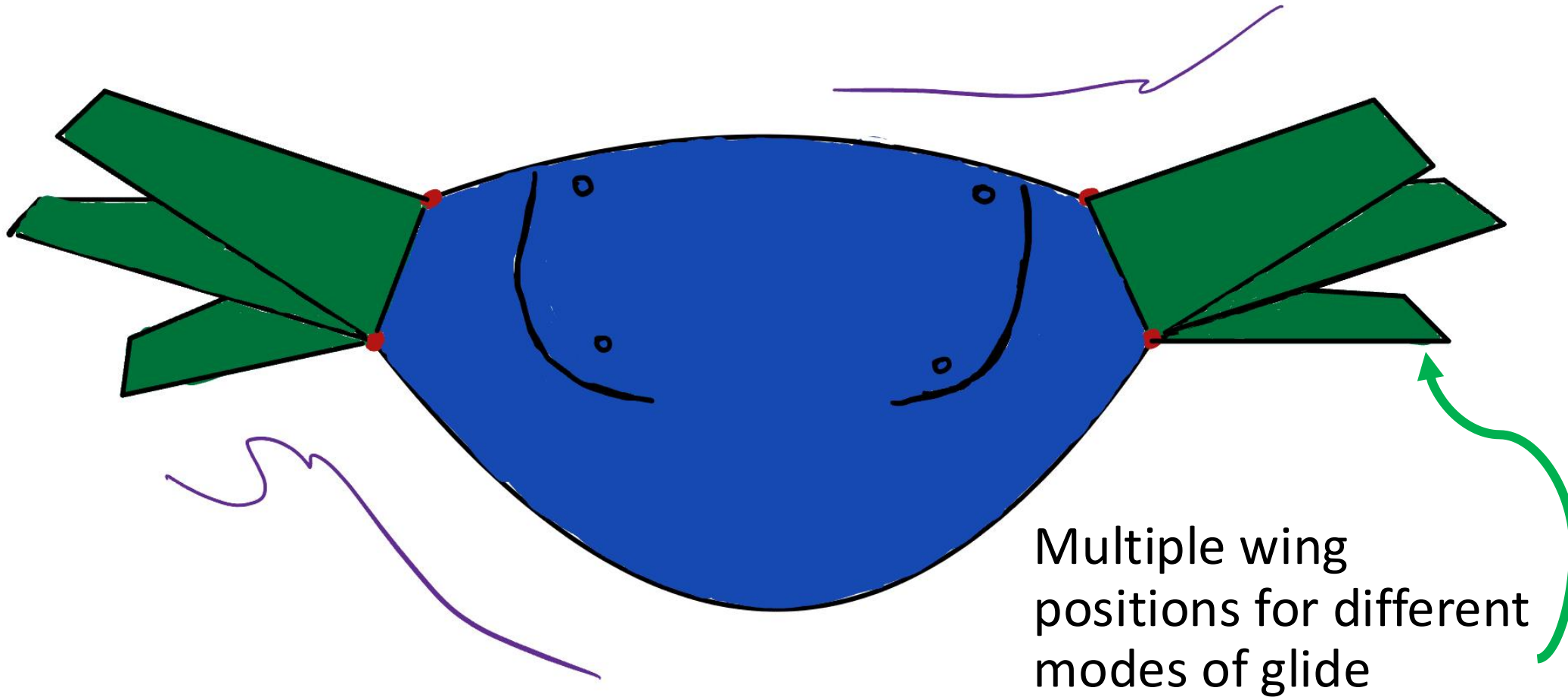

Multiple wing positions for different modes of glide

Piston Glider

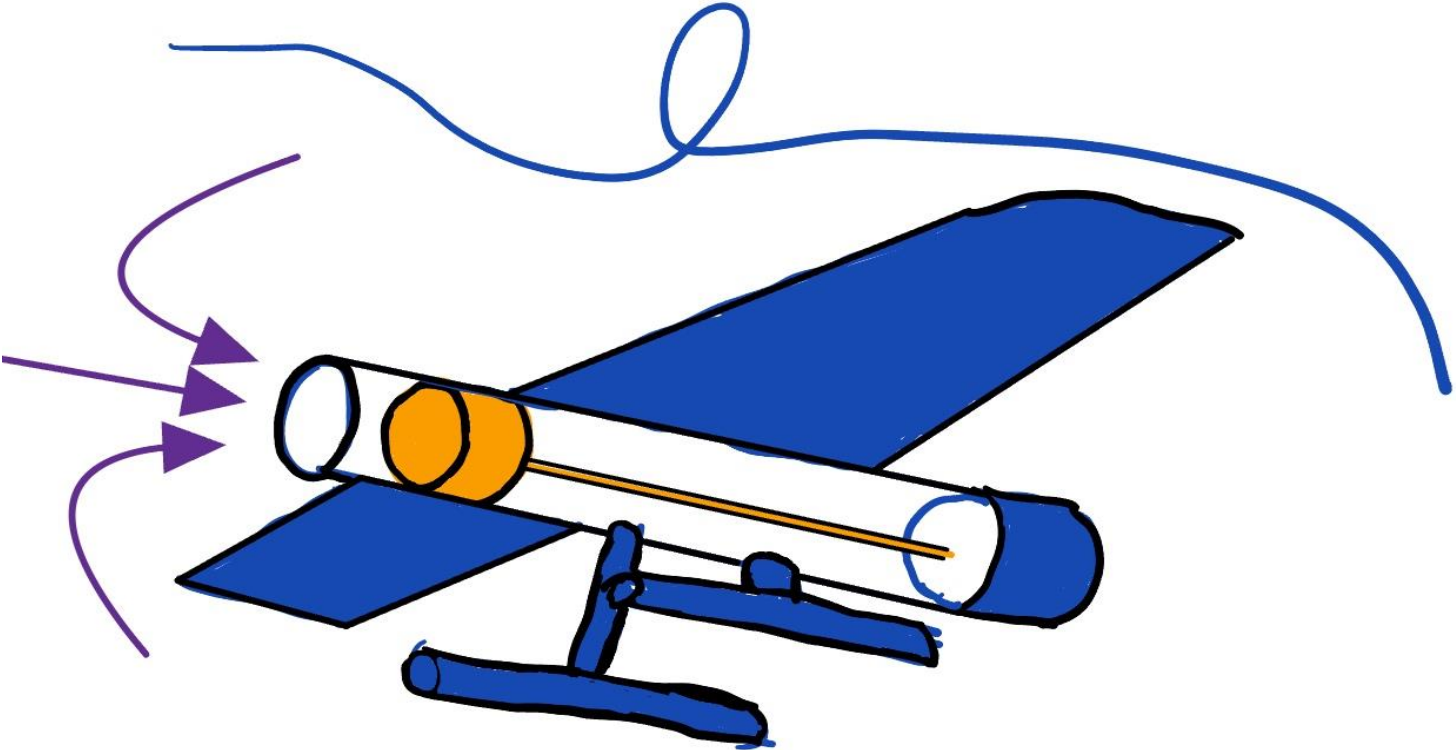

Piston Glider

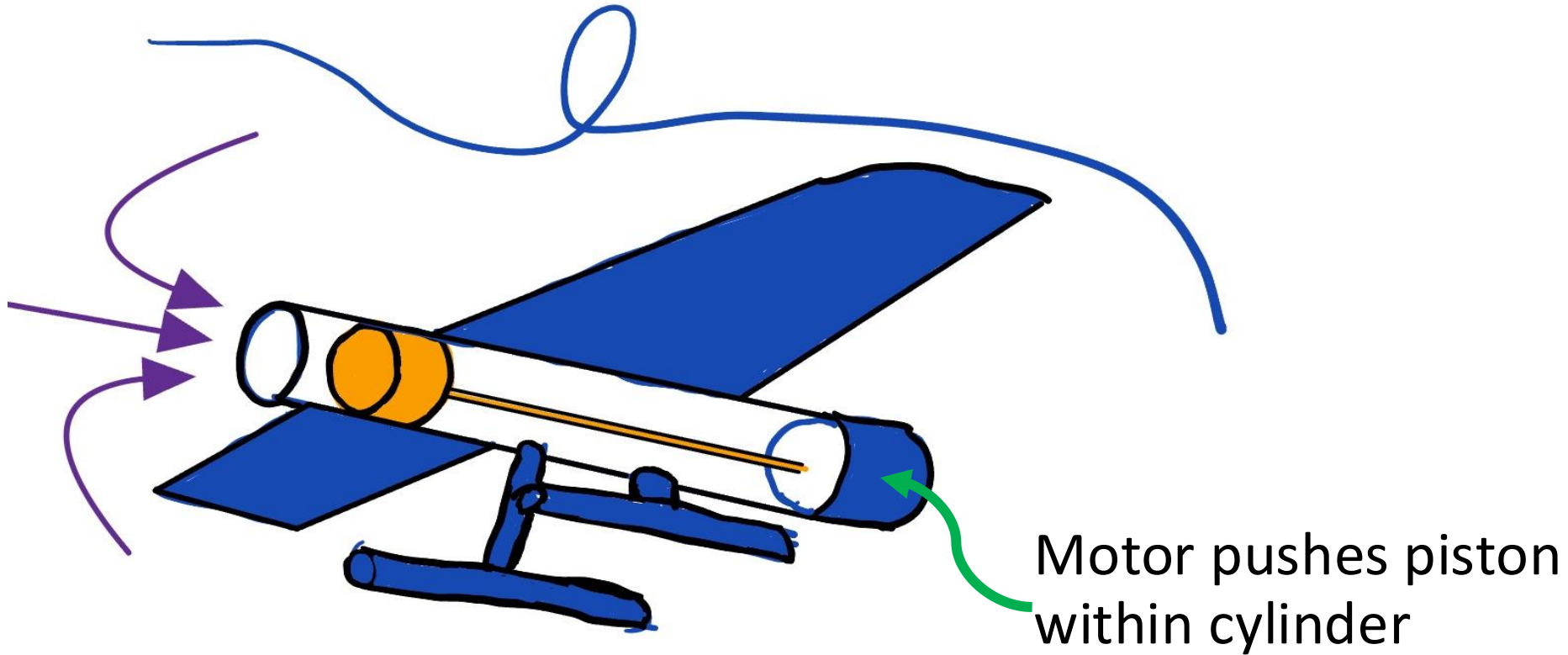

Nicolas Lorin



FAMU-FSU
College of
Engineering

Piston Glider

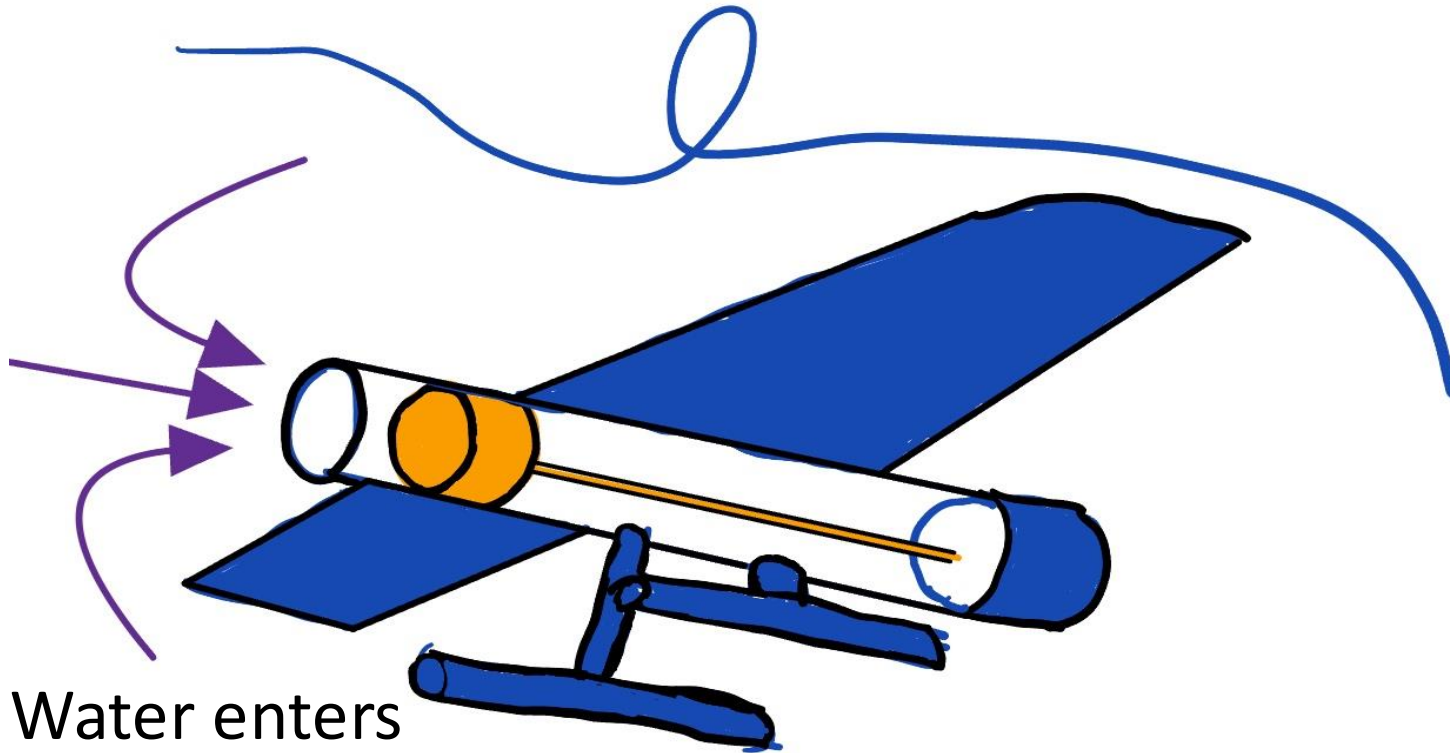

Water enters
chamber,
sinking glider

Piston Glider

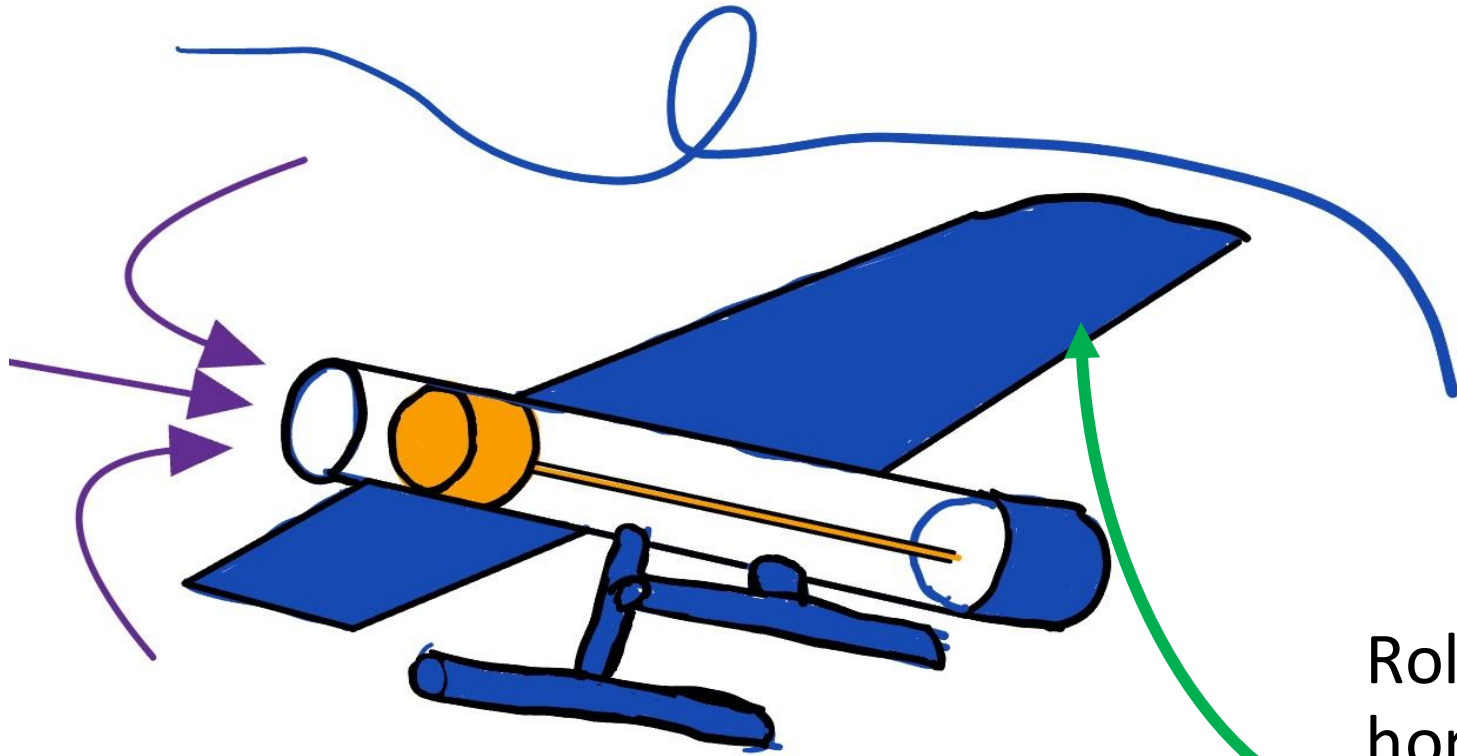

Roll, pitch, & yaw via
horizontal control
surfaces

Concept Selection Process

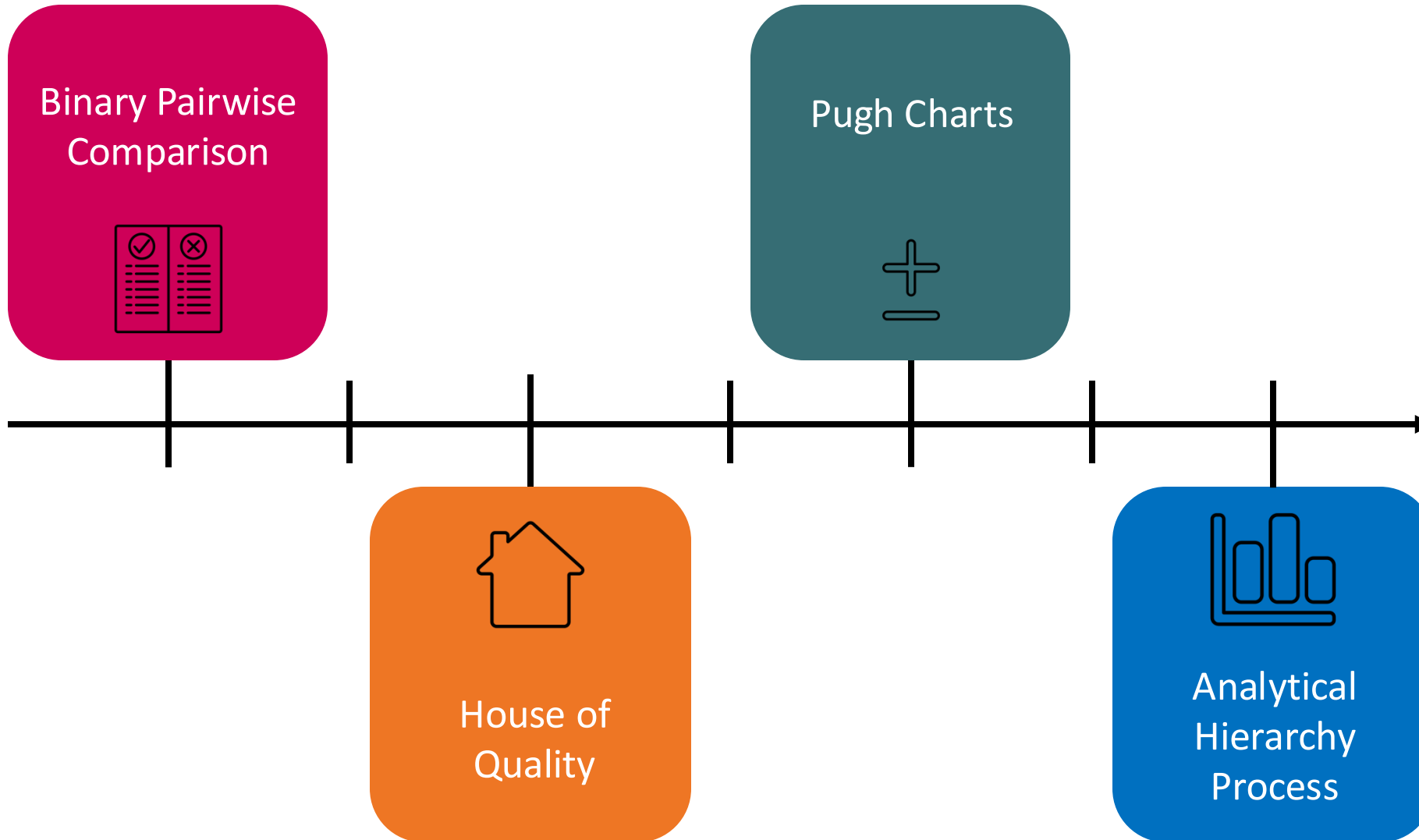

Pairwise Comparison

Survivability

Simulation

Path Optimization



House of Quality

Store Power

3

Store Data

Endure Fatigue
Stress

Regulate Drag

Control Lift

Increase
Buoyancy

4

Decrease
Buoyancy

5

Withstand
Pressure

1

Control
Orientation

2



First Pugh Chart Iteration

Datum



Boeing Wave Glider



Propeller Glider

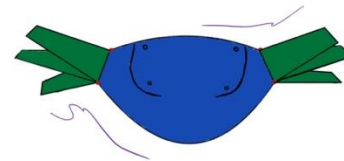

Adjustable Wing Glider

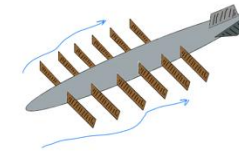

Energy Harvesting Glider

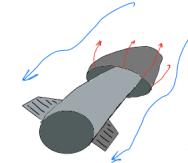

Jellyfish Glider



Piston Glider

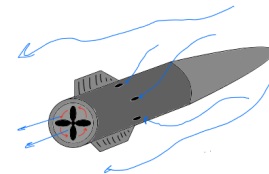

DC Motor Glider

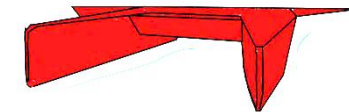

Dual Hull Glider



Second Pugh Chart Iteration

Datum



Propeller
Glider

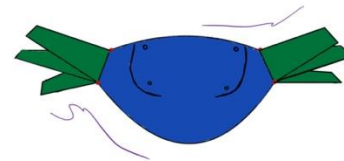

Adjustable Wing
Glider

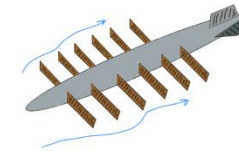

Energy Harvesting
Glider

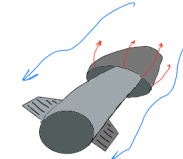

Jellyfish
Glider



Piston Glider

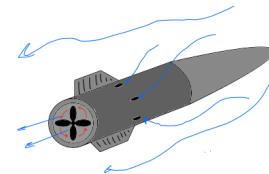

DC Motor Glider

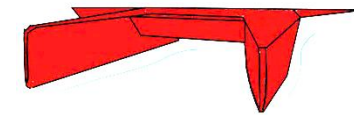

Dual Hull Glider



Analytical Hierarchy Process

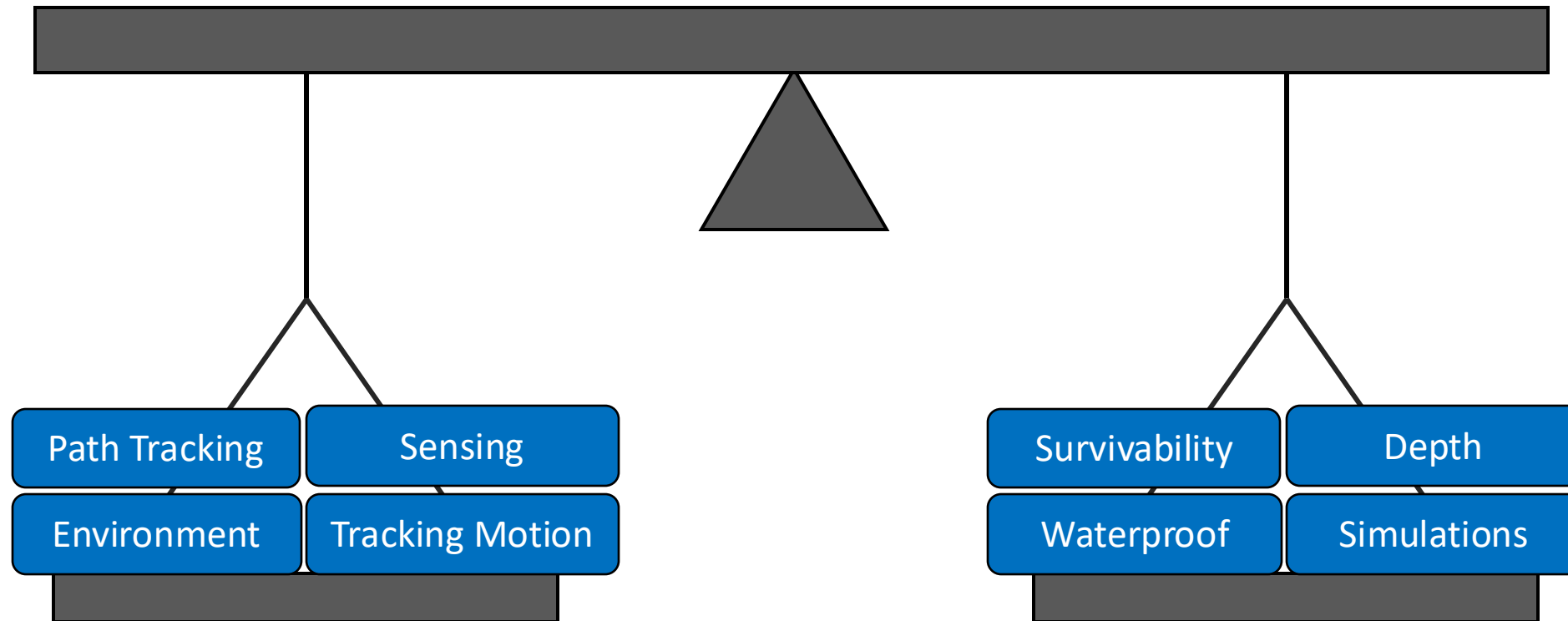

Analytical Hierarchy Process

Alternative Value Chart

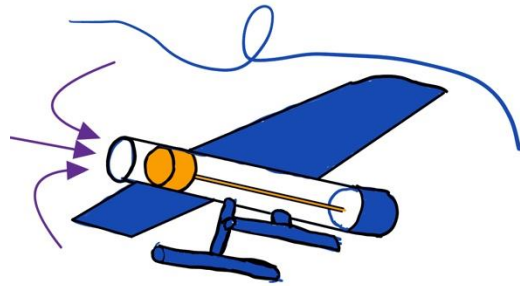

Piston Excavated Buoyancy

0.354

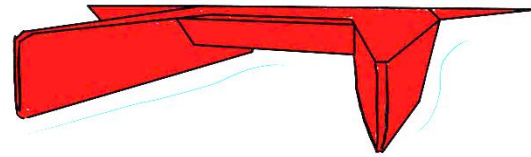

Dual Hull Glider

0.394

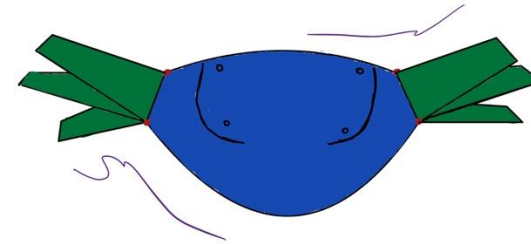

Adjustable Wing Glider

0.253



Analytical Hierarchy Process

Alternative Value Chart

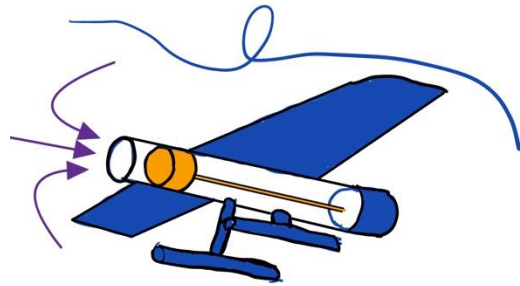

Piston Excavated Buoyancy

0.354

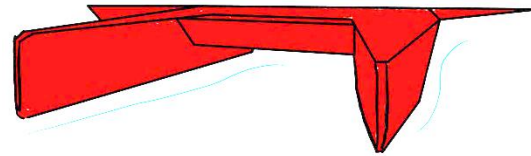

Dual Hull Glider

0.394

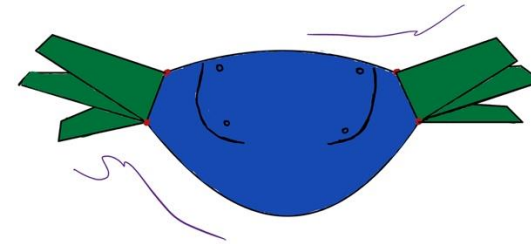

Adjustable Wing Glider

0.253



Final Selection

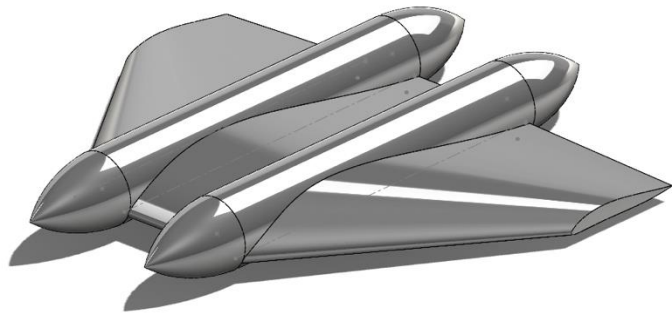
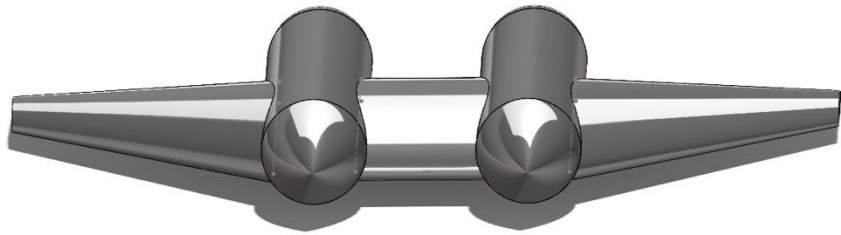

Preliminary CAD Design



Preliminary Glide Profile Animation

Connect on LinkedIn

Jake Burns



Tristan Hardy



Nicolas Lorin



Justin Sepulveda



Martin White

