



FAMU-FSU  
College of  
Engineering

# Powder Removal in Microgravity Environments (PRIME)

**Team 518**

Virtual Design Review 5



# Team Introductions



Cole Daly  
*Mechatronics  
Engineer*



Lauren McNealy  
*Systems Engineer*



Alexander Fryer  
*Project and Test  
Engineer*



FAMU-FSU  
College of  
Engineering

# Team Introductions



Kyle Evans  
*Thermal Fluids  
Engineer*



Tripp Lappalainen  
*Manufacturing  
and Design Engineer*



Chelsea Kiselewski  
*Quality and Design  
Engineer*

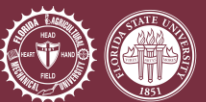

# Sponsor and Advisor



Project Sponsor

Justin McElderry

Materials Engineer -

NASA Marshall Space Flight Center



Academic Advisor

McConomy, Shayne Ph.D.

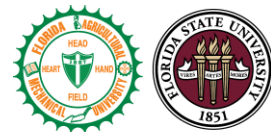

FAMU-FSU  
College of  
Engineering



FAMU-FSU  
College of  
Engineering

# Objective

The objective of this project is to develop a proof-of-concept device for removing powder residue from additive manufactured parts in microgravity environments.

Clean

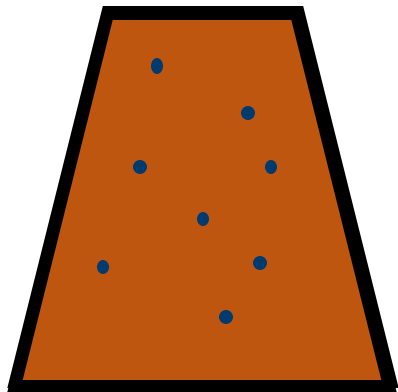

Remove



Contain

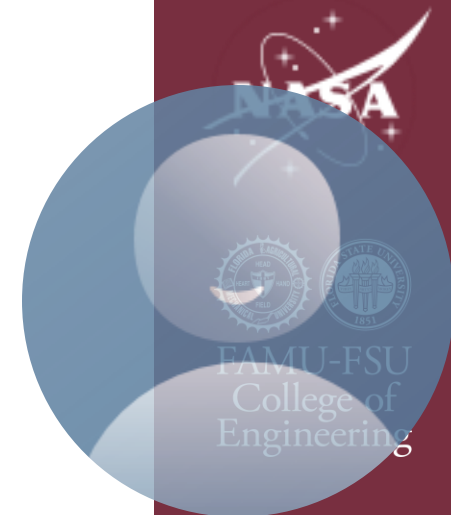
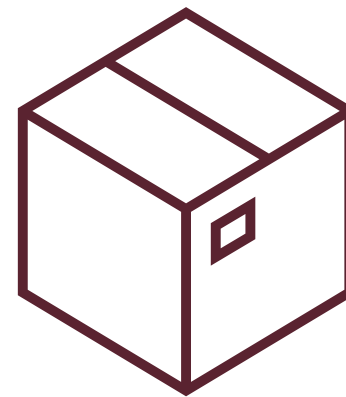

# Objective

The objective of this project is to develop a proof-of-concept device for removing powder residue from additive manufactured parts in microgravity environments.

Remove

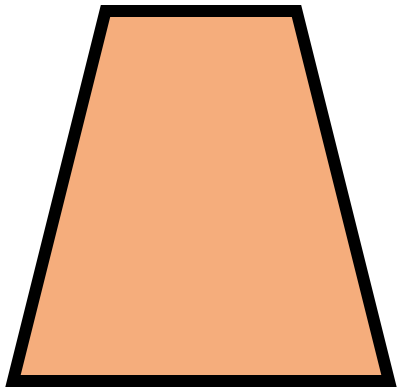

Move

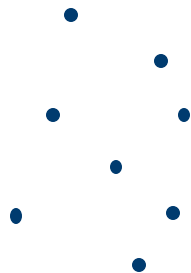

Contain

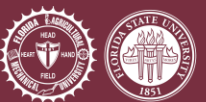
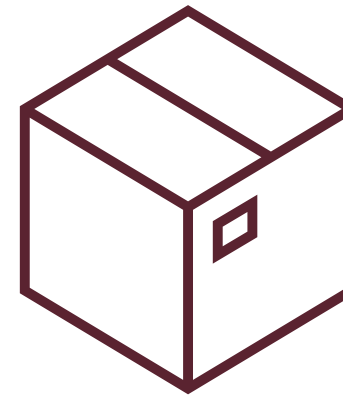

# Project Background

**Additive Manufacturing offers:  
Rapid Prototyping  
Reduced Production Time**

Trapped powder  
inside parts

Hazardous  
particles in  
microgravity

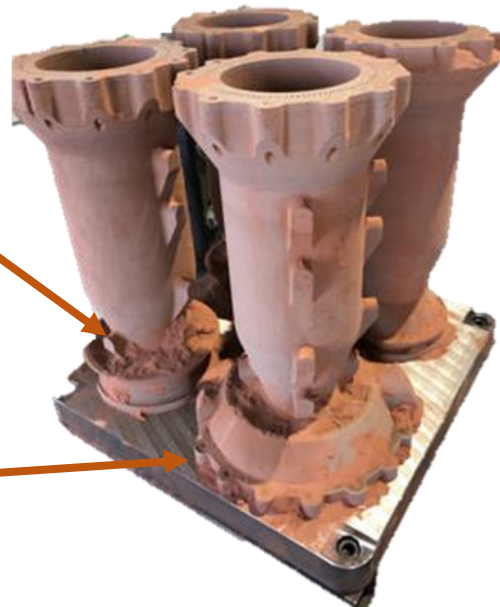

**Goal: Portable  
cleaning  
device to  
bring to ISS**

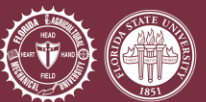

FAMU-FSU  
College of  
Engineering

# Key Goals



**Automatic  
Operation**

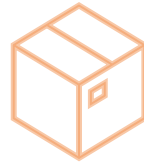

**Contain Dirty  
Solvent**



**Functions  
in Microgravity**



**Clean Internal  
Features**



**Durable**

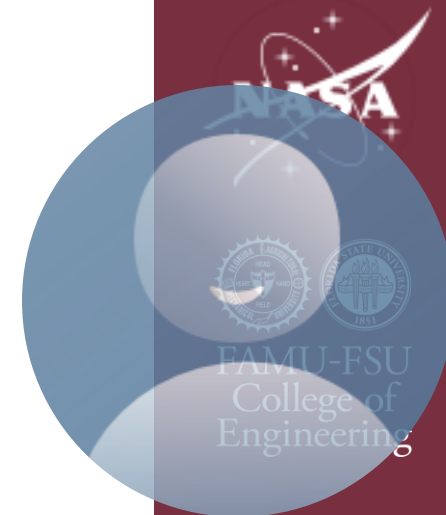



# Targets and Metrics

Design will be able to  
clean 85-90% of debris

## Cleaning

Particles are contained with  
no leaks in the device

## Containment/Safety

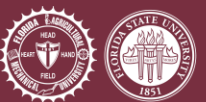

# Concept Selection Overview

Liquid Nitrogen Spray

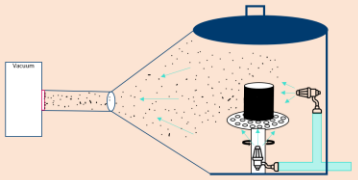

Sonic Wave Cleaner

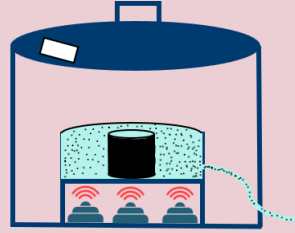

Vacuum Nucleation

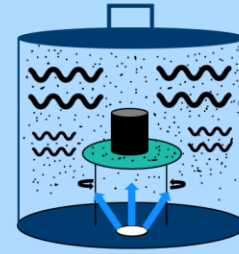

Dishwasher

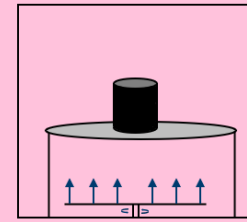

Momentum Shaker

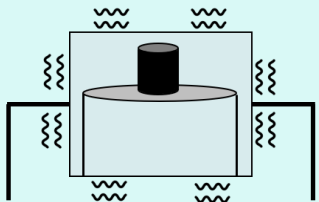

Shop-Vac Hose

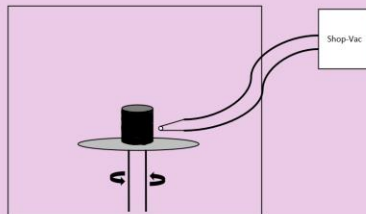

Spinning Plate

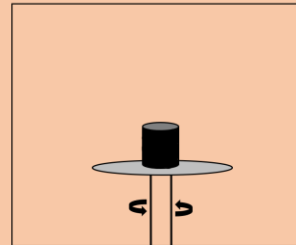

Boiling Water

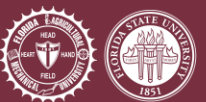
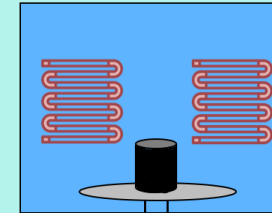

# Sonic Wave Cleaner

- Sonic waves pulsed underneath fluid
- Fluid is spun creating vortices
- Air will be pushed into the main body, while drain valve is opened

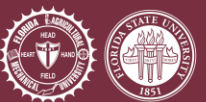

# Project Overview/Updates

## How will our prototype function:

- Sensors, sit flush against the bottom of the main body
- Sensors produce a cone of frequency; this cone will ensure the part area is covered

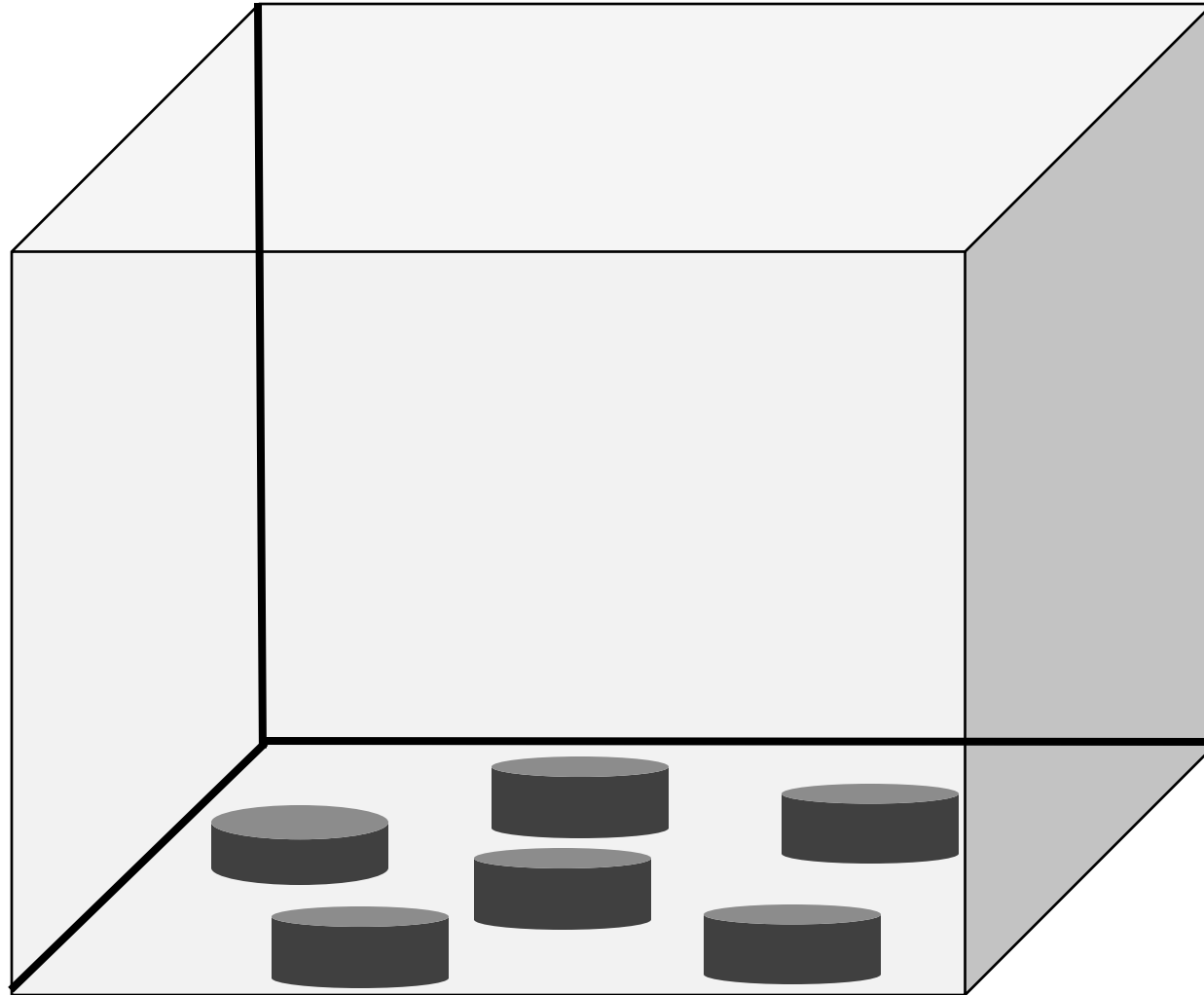

# Project Overview/Updates

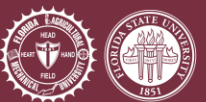
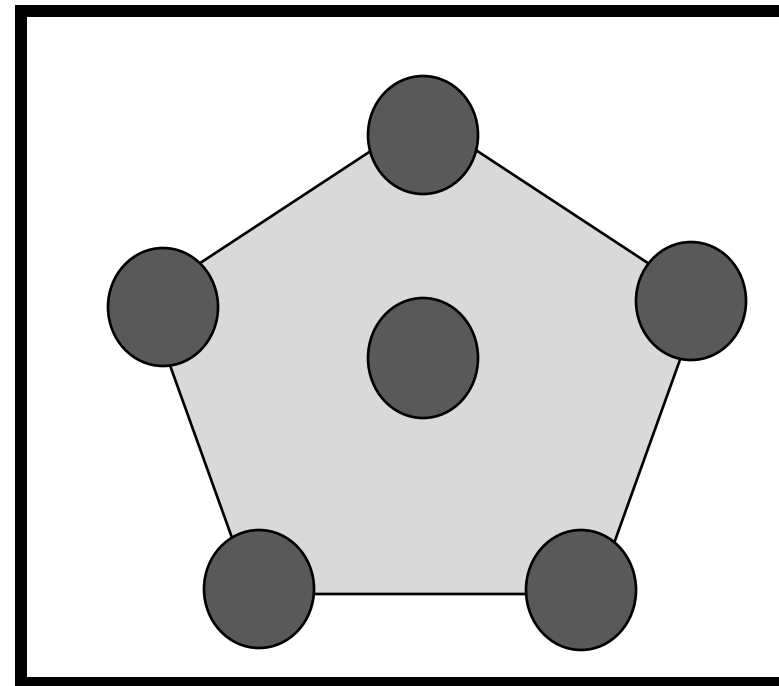
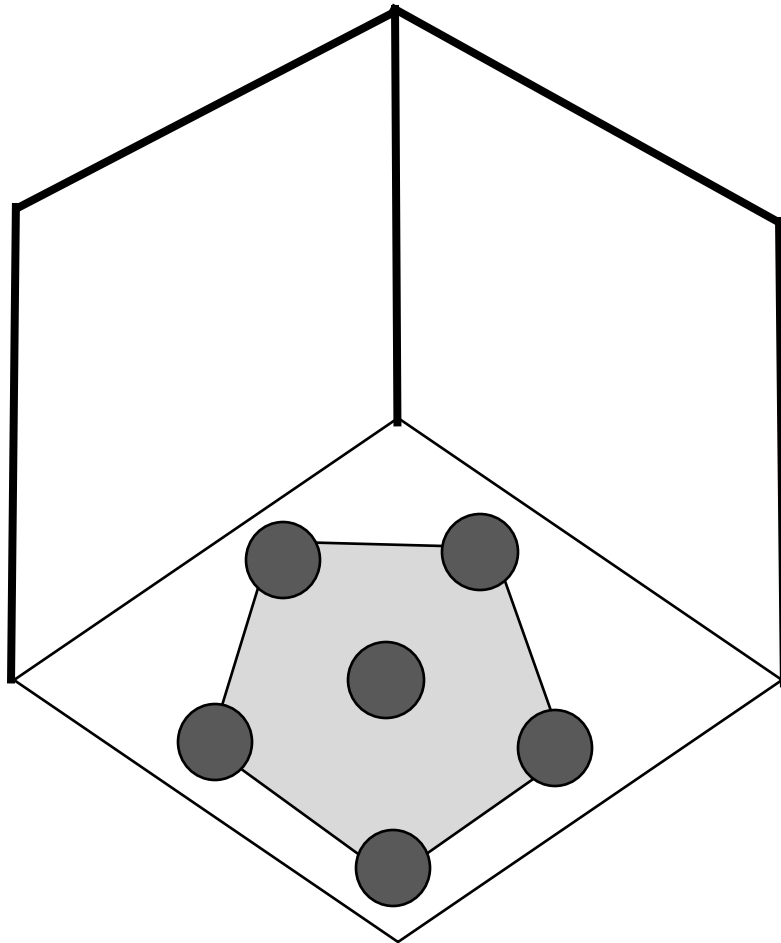

# Project Overview/Updates

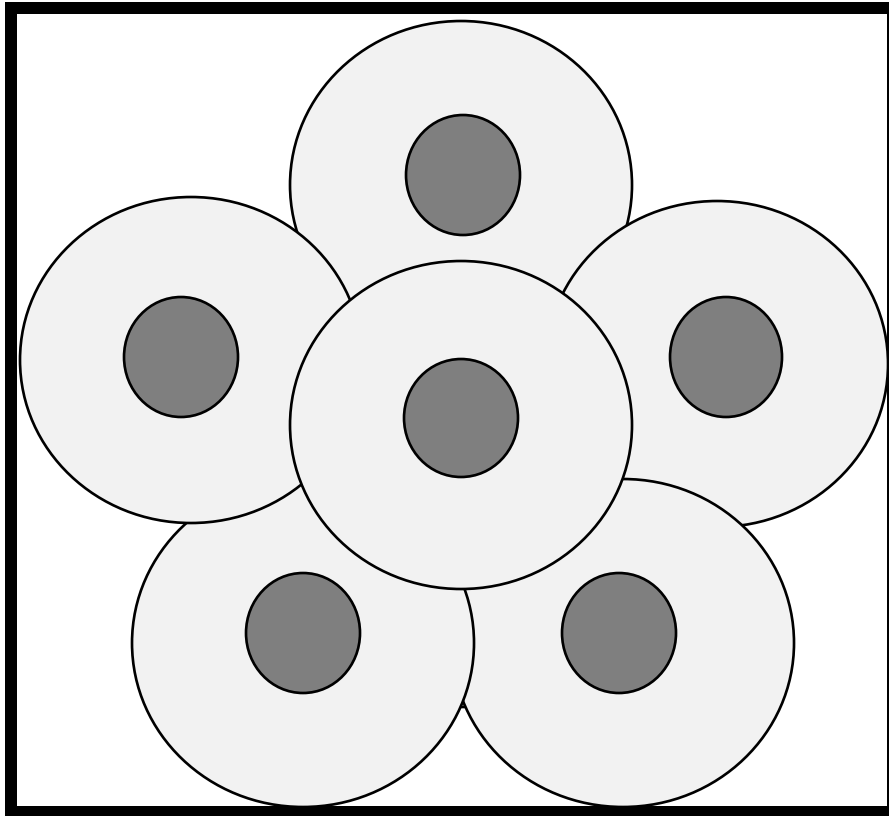

## Why:

- Rectangular mesh basket is covered by all the sensors
- The location of the stands holding the box off the ground are located on the corners

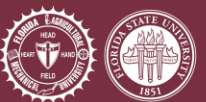

# Operation

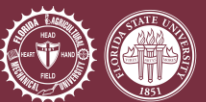
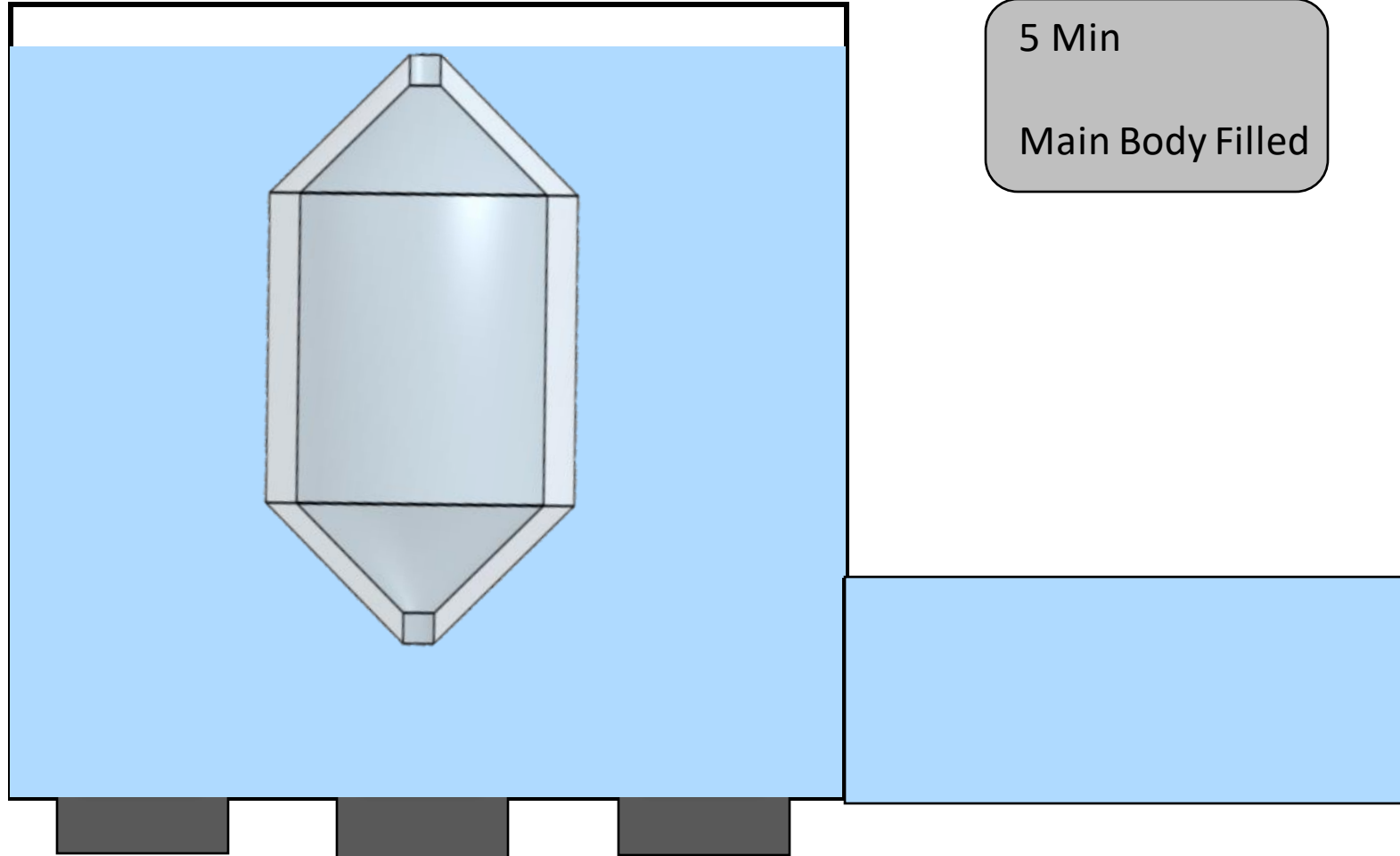

# Operation

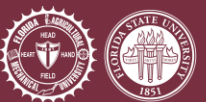
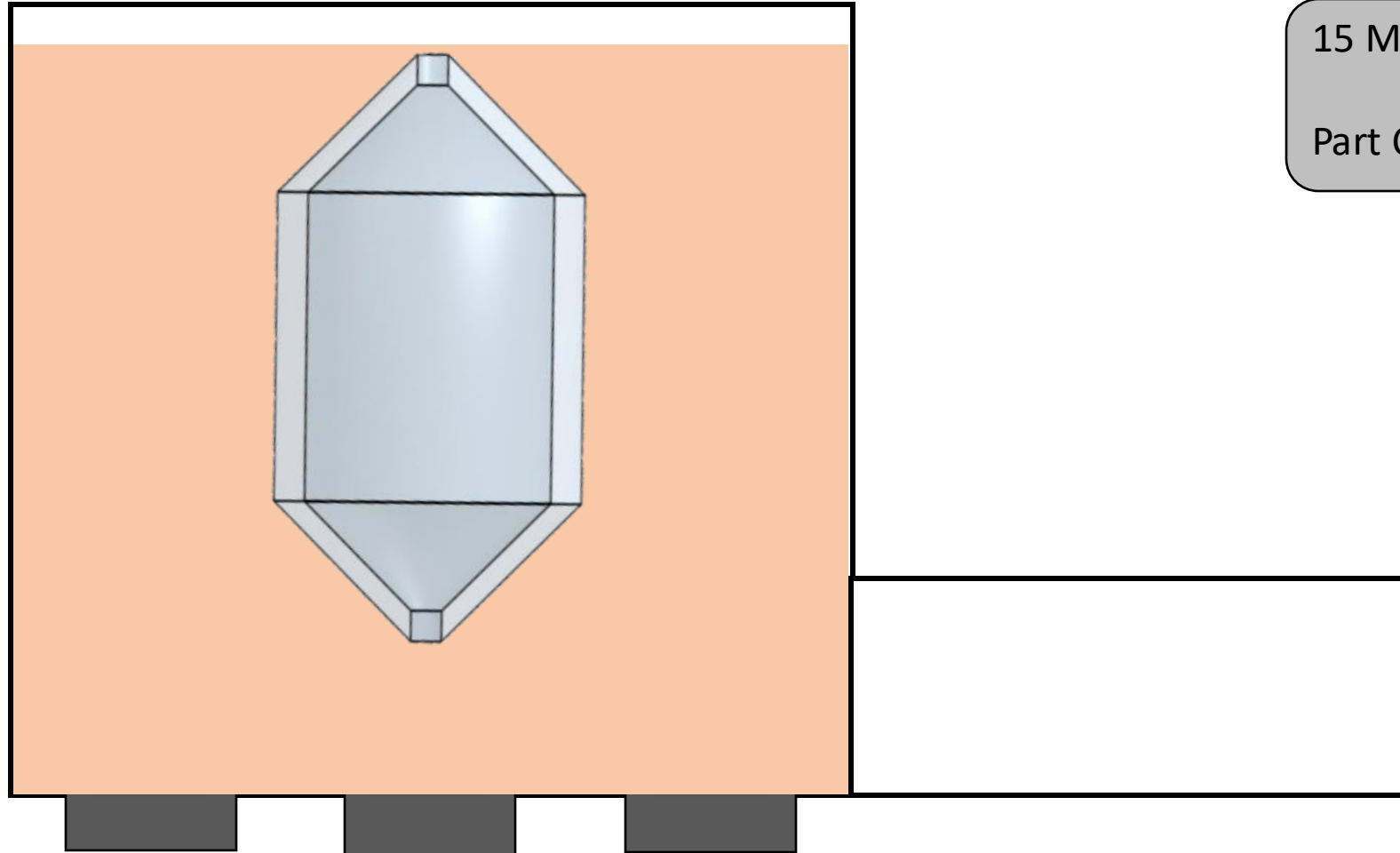



# Operation

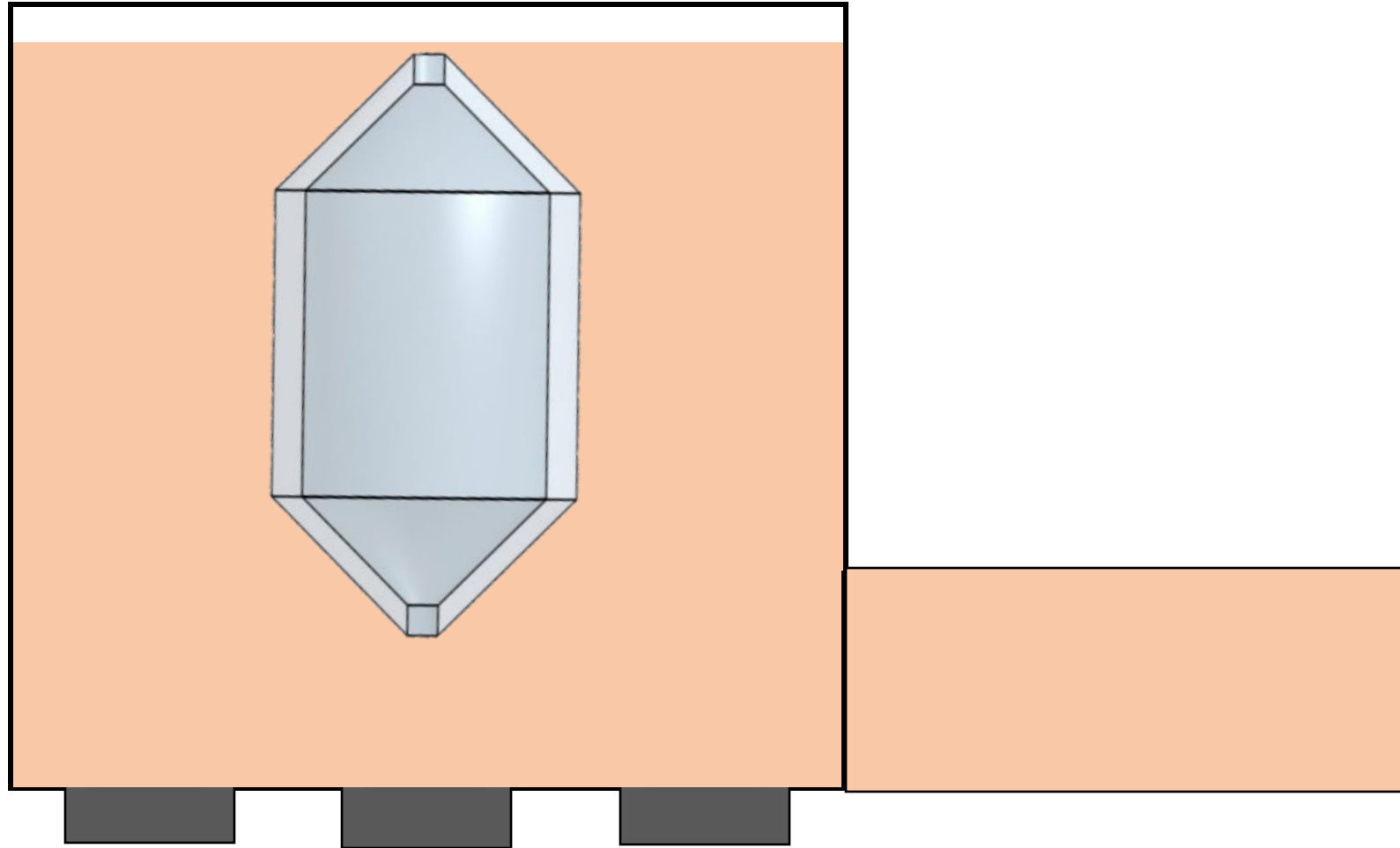

20 Min  
Drained

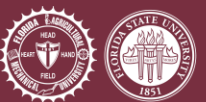

# Flow Analysis

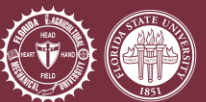
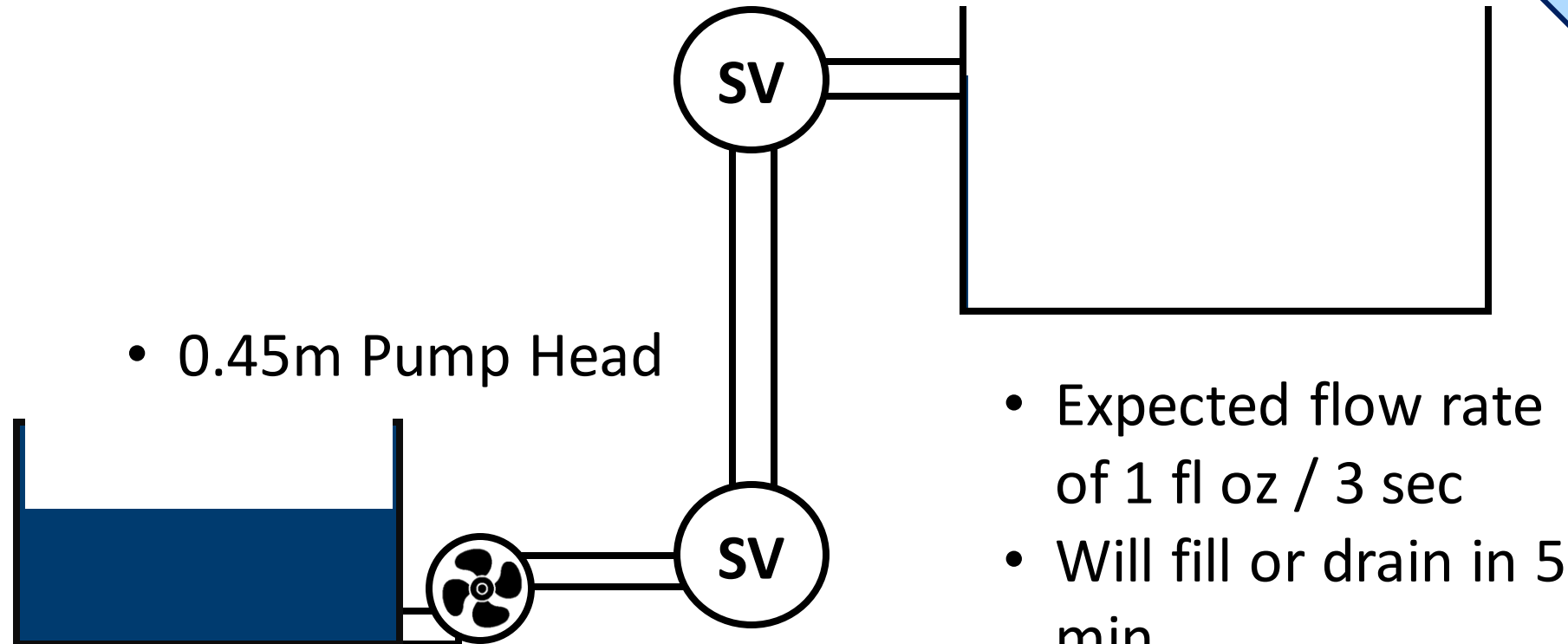

# Gasket for Sealing the Lid

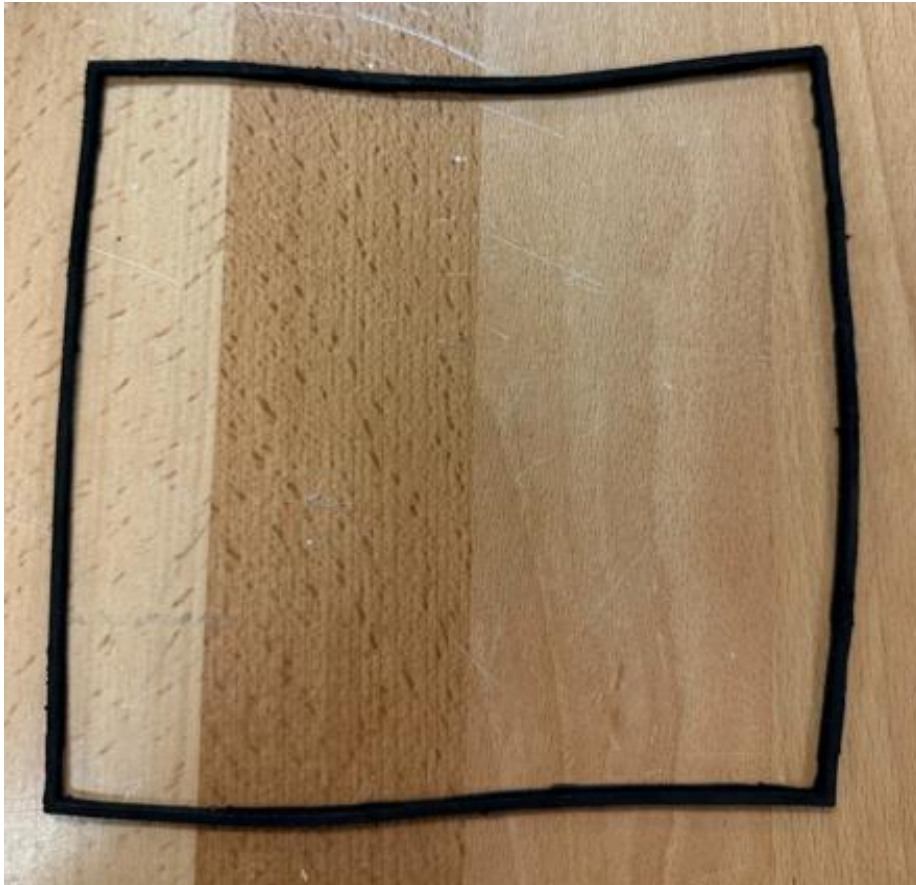

- Buna-n gasket selected
- Excellent resistance to oils and grease
- Laser cut for precise shape
- Multiple passes at low power done to avoid embrittlement

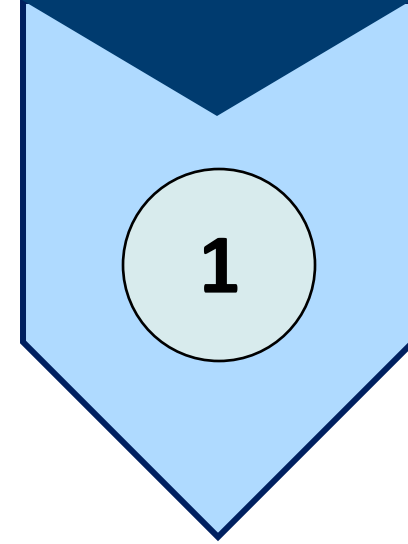

# Electrical Progress

1

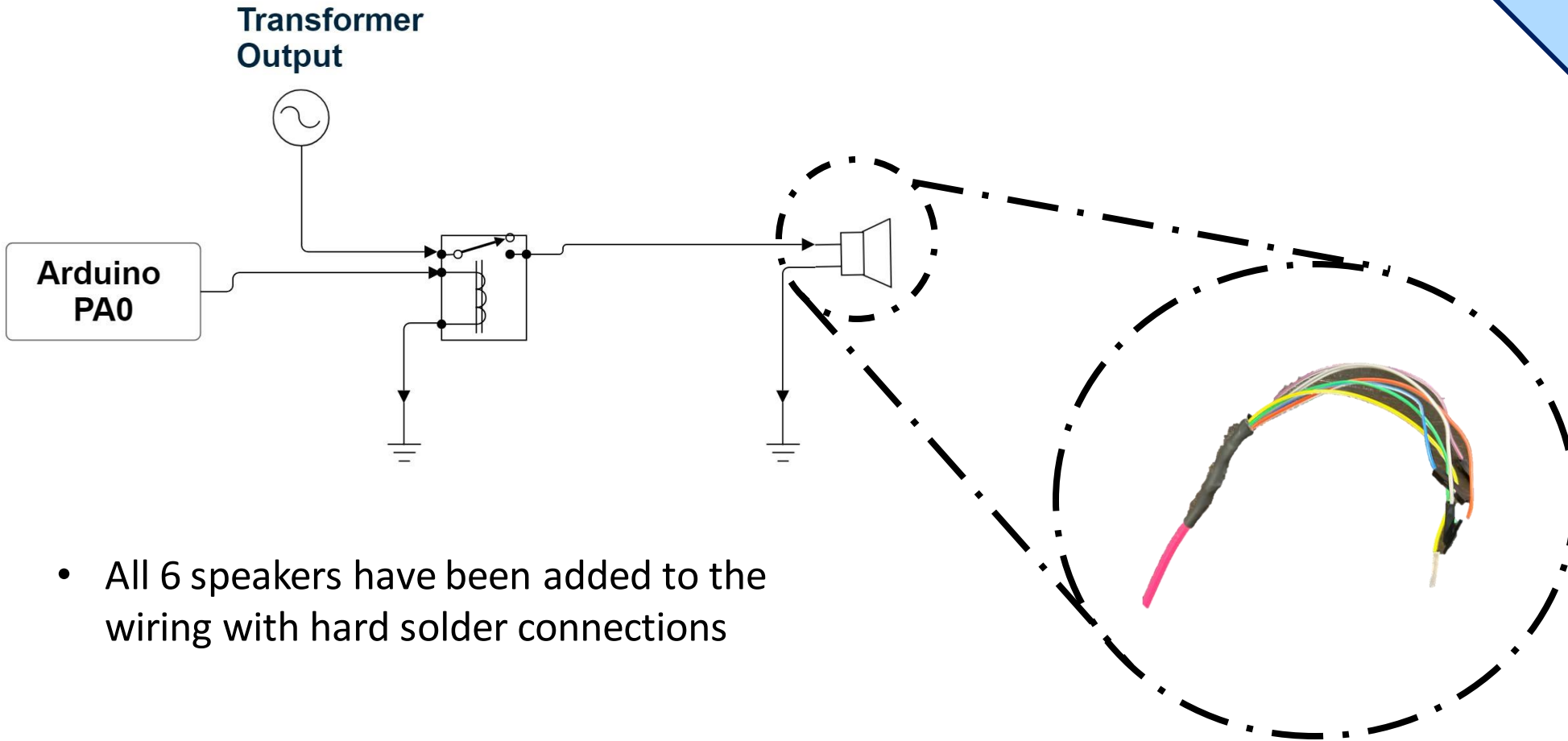

- All 6 speakers have been added to the wiring with hard solder connections

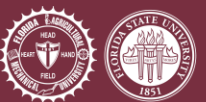

# Inner Components



- The mesh basket will be secured to the sides of the main body
- It will hold contaminated part to avoid damage
- Size is 5" x 5" x 4.5"

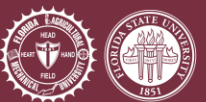
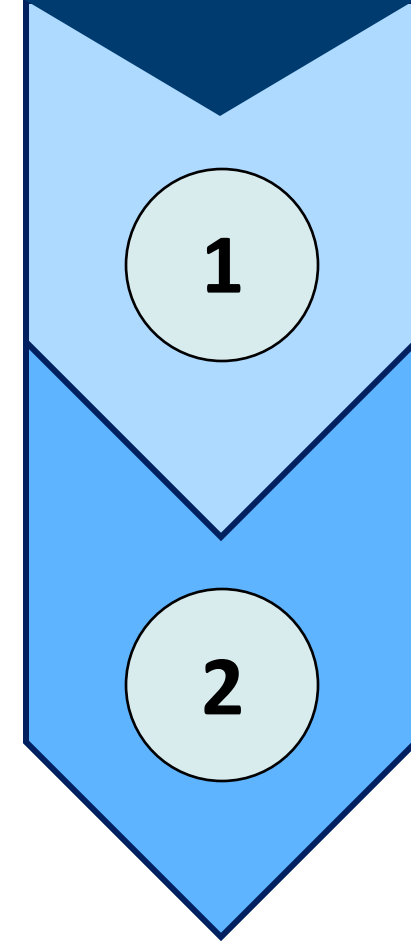

# Current Work

## Preliminary Creo Design



- The mesh will go into the machine fitted with the black lid on top
- Sealed with two latches

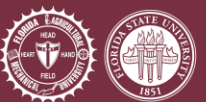
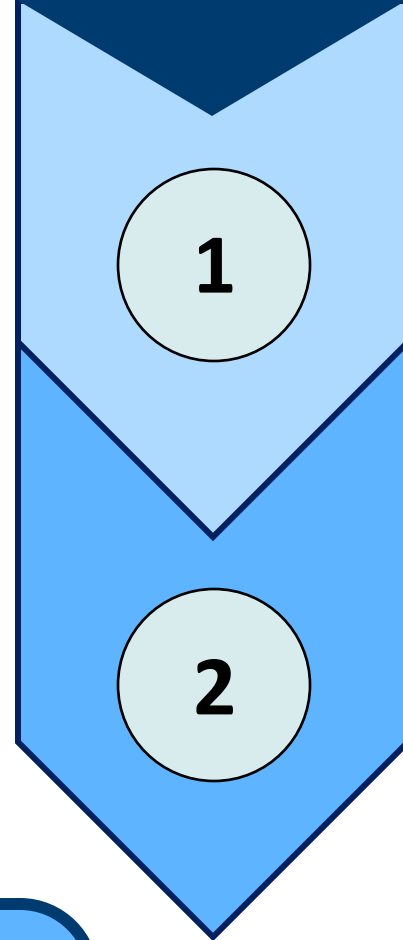

# Current Work

## Test Part

- Height of part is 1in
- 1/20" hole
- Hollow
- SLS Nylon 12 (Particle Size  $\approx 40 \mu m$ )

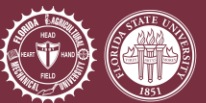
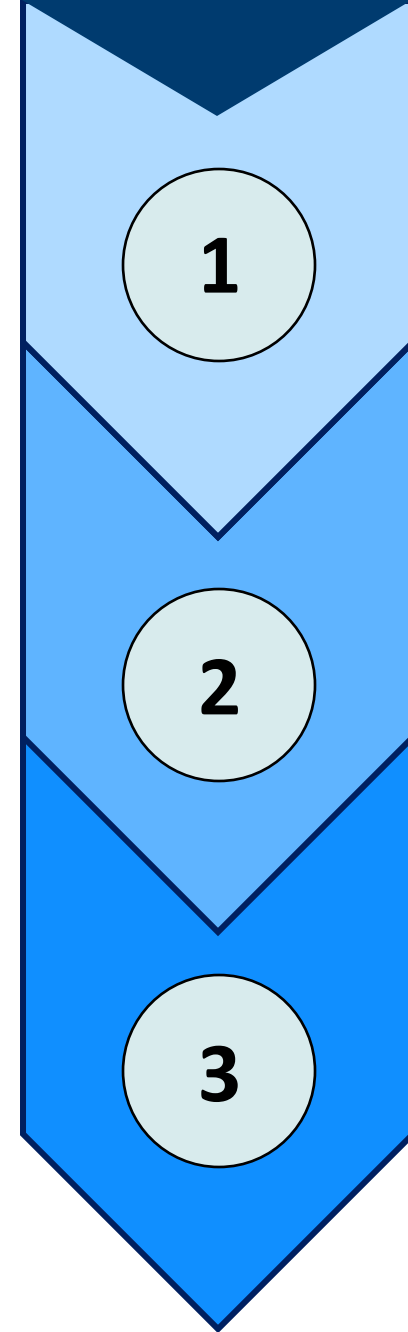
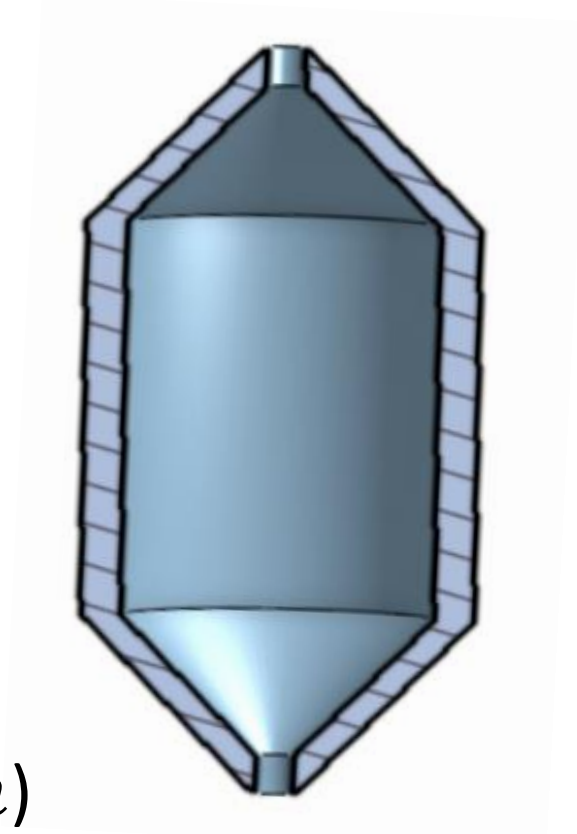

# Current Work

## Preliminary Creo Design

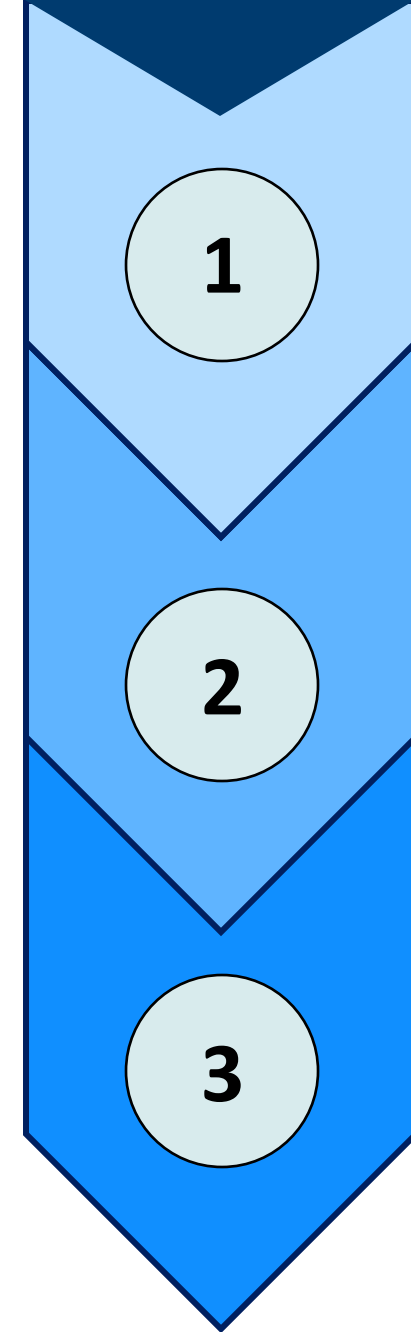
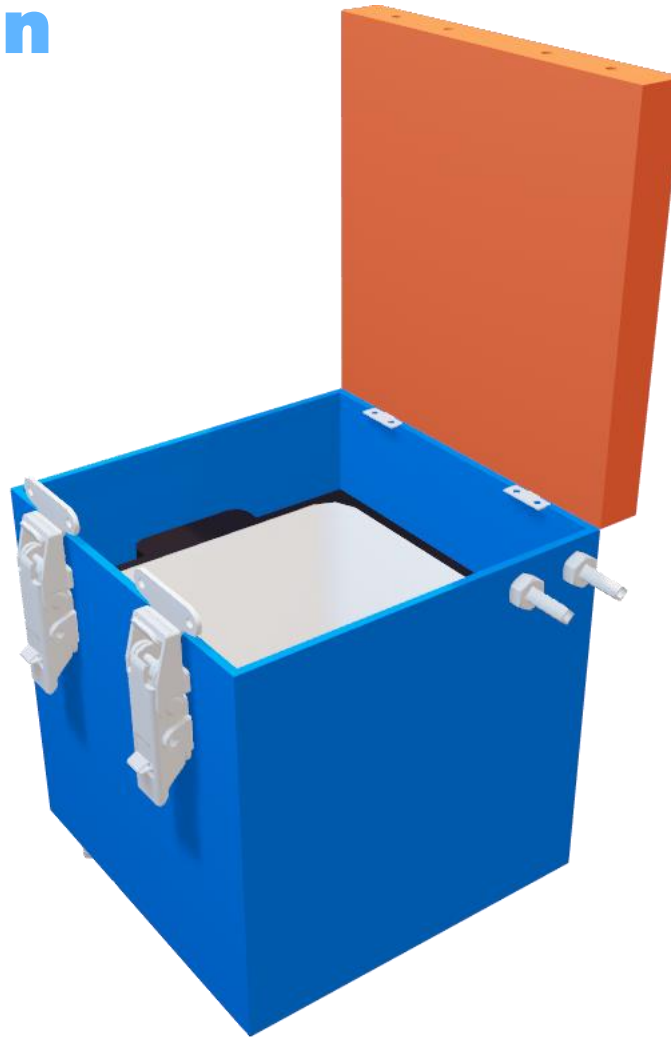
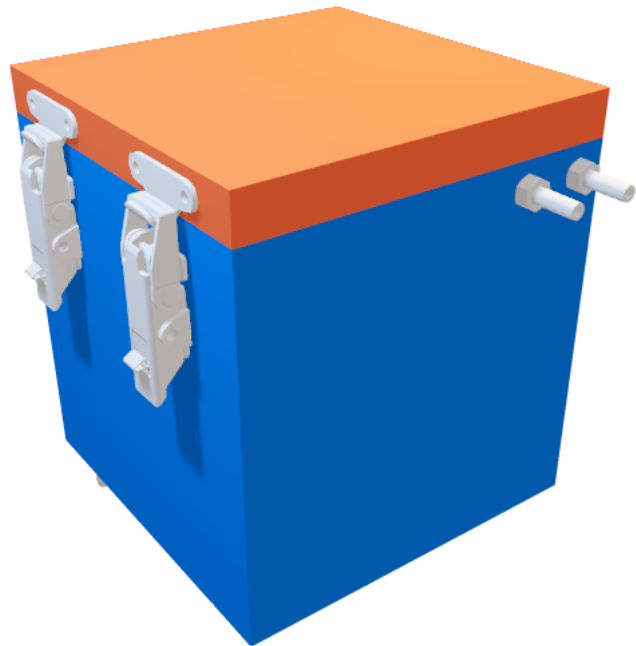



# Current Budget

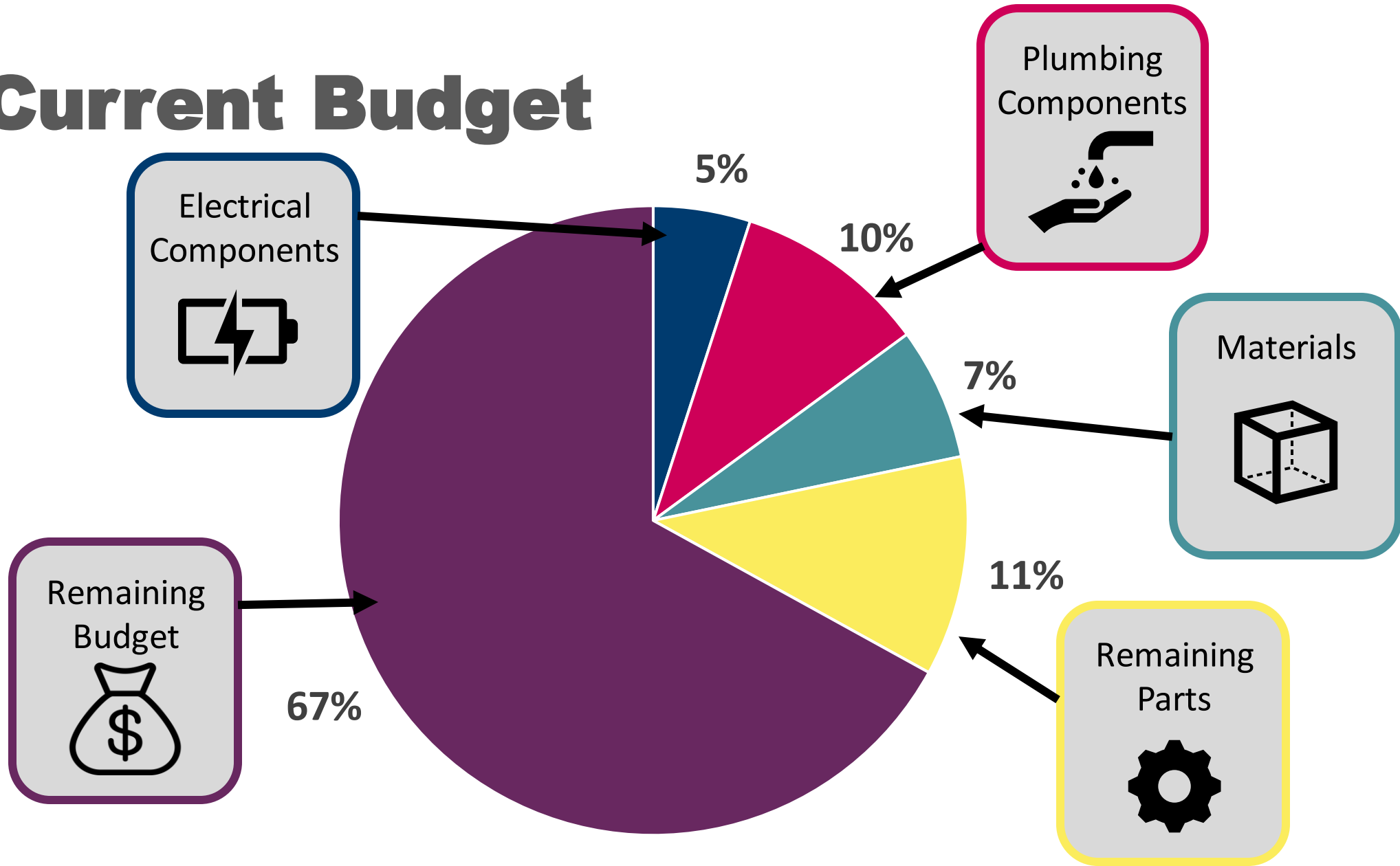

# Current Budget

- - Electrical Components - \$99.73
- - Plumbing Components - \$198.75
- - Materials - \$136.19
- - Remaining Parts - \$225.75

■ - Remaining Budget - \$1339.58

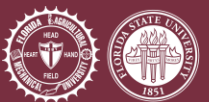
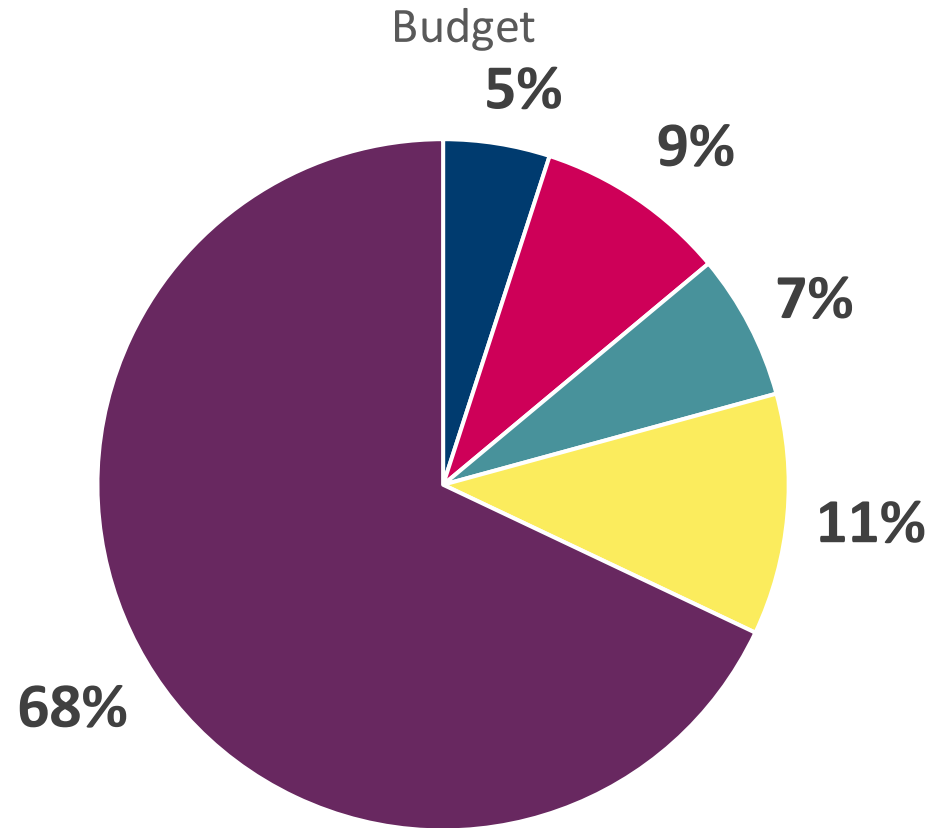

# Future Work

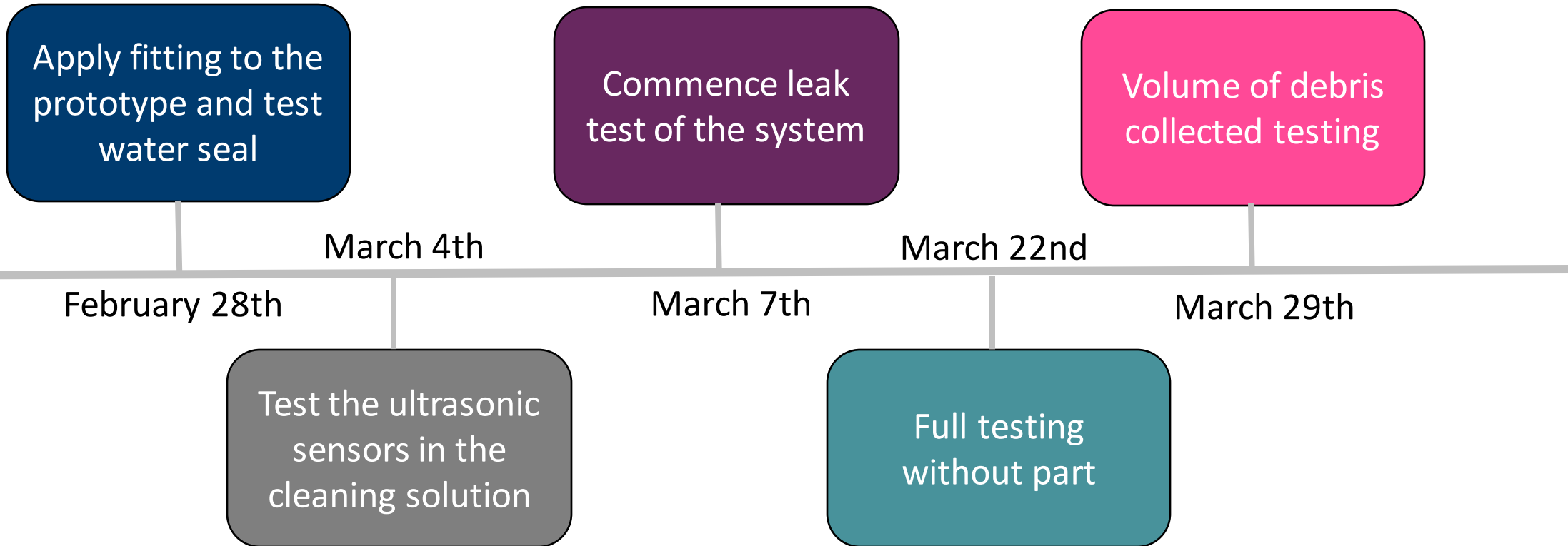

# Questions



FAMU-FSU  
College of  
Engineering