



FAMU-FSU  
College of  
Engineering

# Powder Removal in Microgravity Environments (PRIME)

**Team 518**

Virtual Design Review 4

# Team Introductions



Kyle Evans  
*Thermal Fluids  
Engineer*



Tripp Lappalainen  
*Manufacturing  
and Design Engineer*



Chelsea Kiselewski  
*Quality and Design  
Engineer*

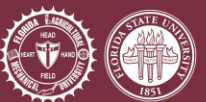

# Team Introductions



Cole Daly  
*Mechatronics  
Engineer*



Lauren McNealy  
*Systems Engineer*



Alexander Fryer  
*Project and Test  
Engineer*

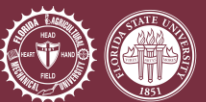

# Sponsor and Advisor



Project Sponsor

Justin McElderry

Materials Engineer -

NASA Marshall Space Flight Center



Academic Advisor

McConomy, Shane Ph.D.

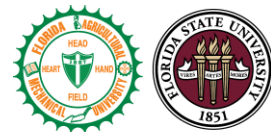

FAMU-FSU  
College of  
Engineering

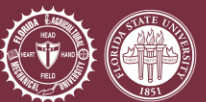

FAMU-FSU  
College of  
Engineering

# Objective

The objective of this project is to develop a proof-of-concept device for removing powder residue from additive manufactured parts in microgravity environments.

Clean

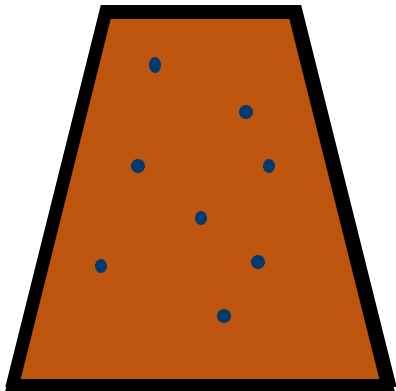

Remove

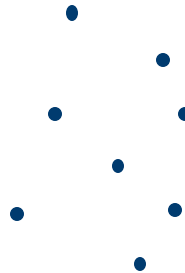

Contain

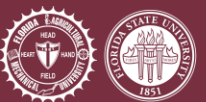
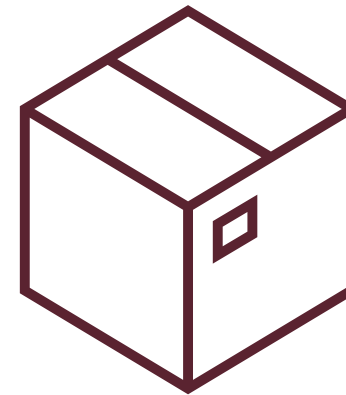

# Project Background

**Additive Manufacturing offers:  
Rapid Prototyping  
Reduced Production Time**

Trapped powder  
inside parts

Hazardous  
particles in  
microgravity

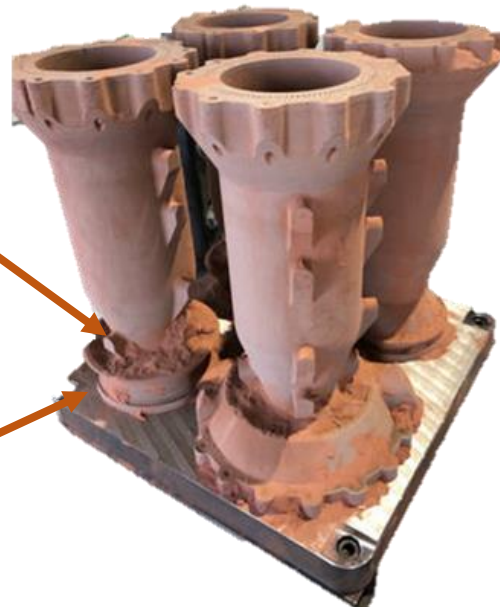

**Goal: Portable  
cleaning  
device to  
bring to ISS**



# Key Goals

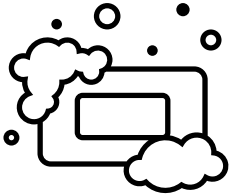

**Clean Internal  
Features**

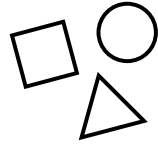

**Clean Multiple  
Parts**



**Functions  
in Microgravity**

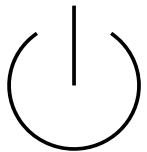

**Automatic  
Operation**

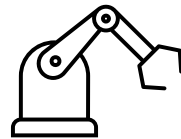

**Physical  
Prototype**

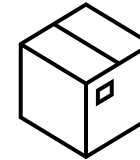

**Contain Dirty  
Solvent**

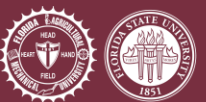

# Targets and Metrics

Design will be able to  
clean 85-90% of debris

## Cleaning

Particle are contained with  
no leaks in the device

## Containment/Safety

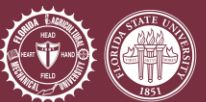



# Concept Selection Overview

**Liquid Nitrogen Spray**

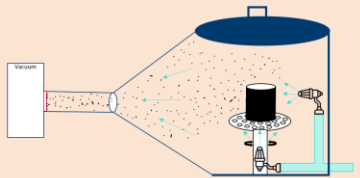

**Sonic Wave Cleaner**

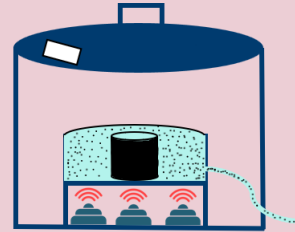

**Vacuum Nucleation**

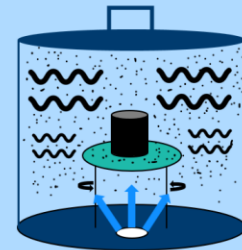

**Dishwasher**

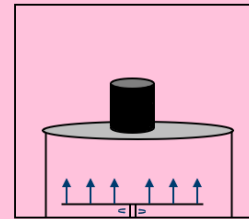

**Momentum Shaker**

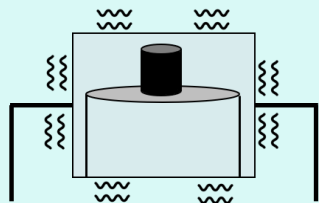

**Shop-Vac Hose**

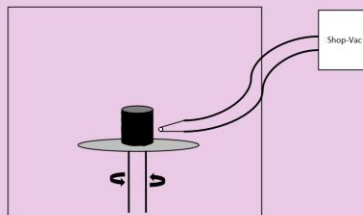

**Spinning Plate**

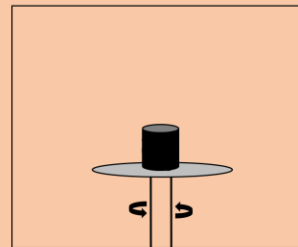

**Boiling Water**

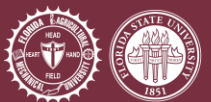
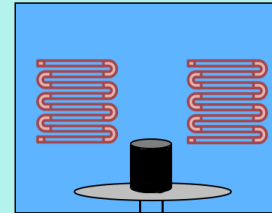

# Sonic Wave Cleaner

- Sonic waves pulsed underneath fluid
- Fluid is spun creating vortices
- Fluid is drained while being spun to keep the particles away

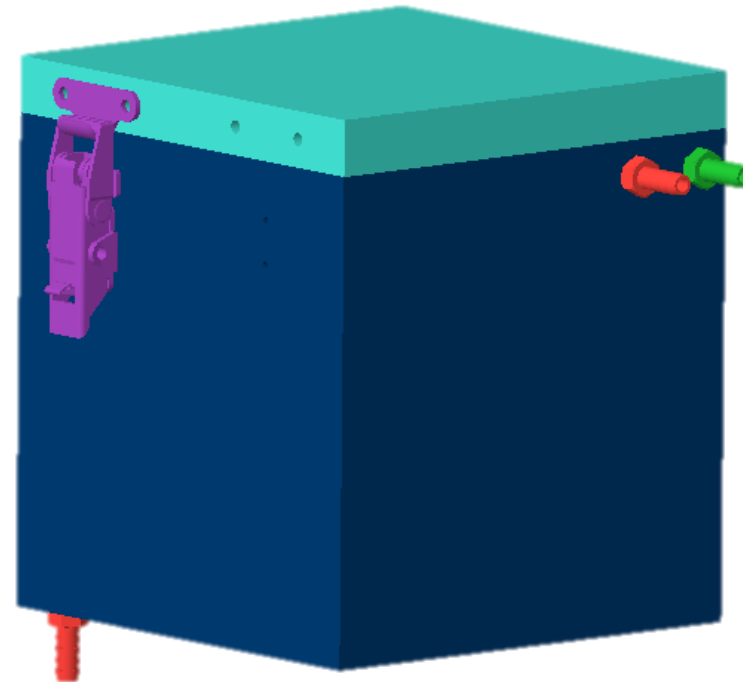

# Current Work

## Preliminary Wire Diagram

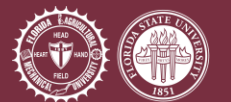
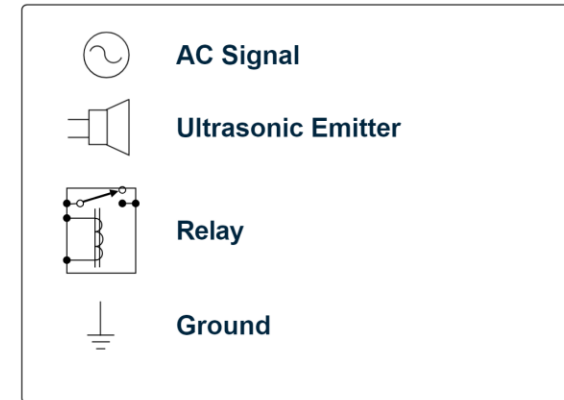
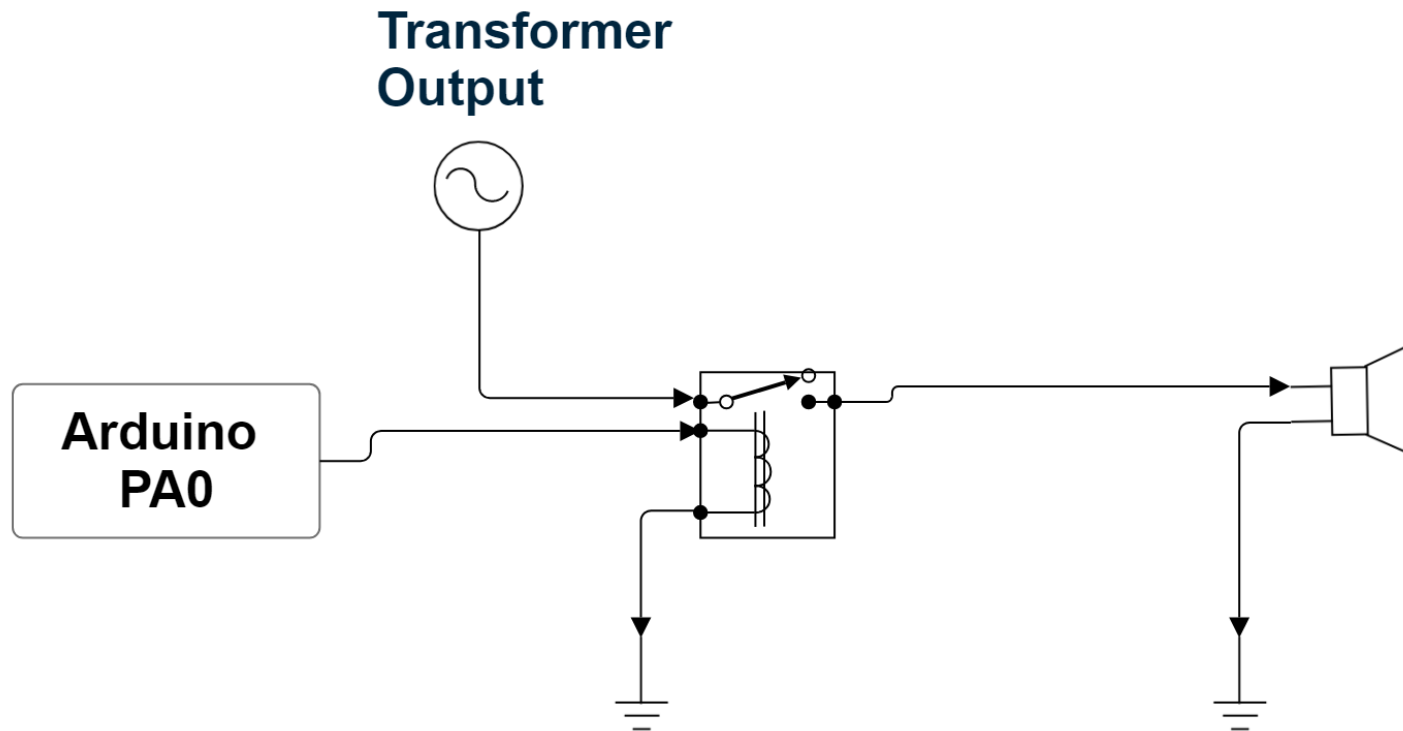
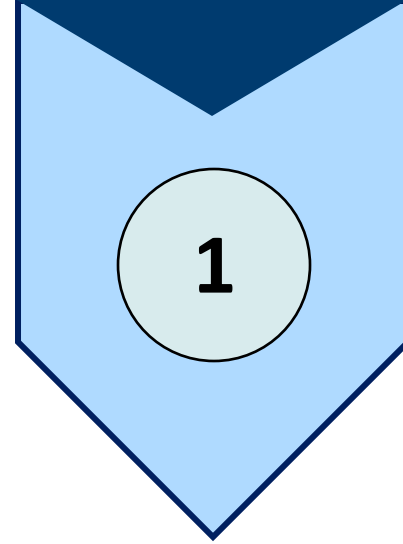

# Current Work

## Preliminary Valve Wire Diagram

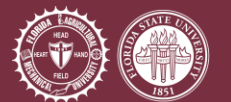
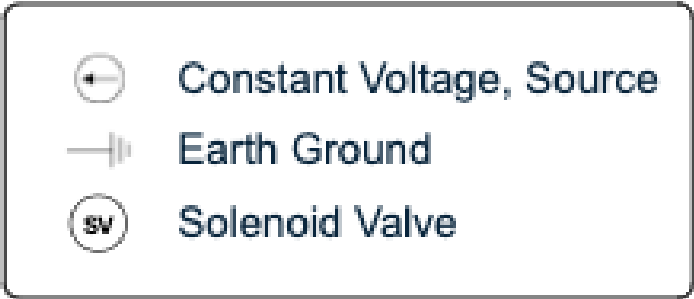
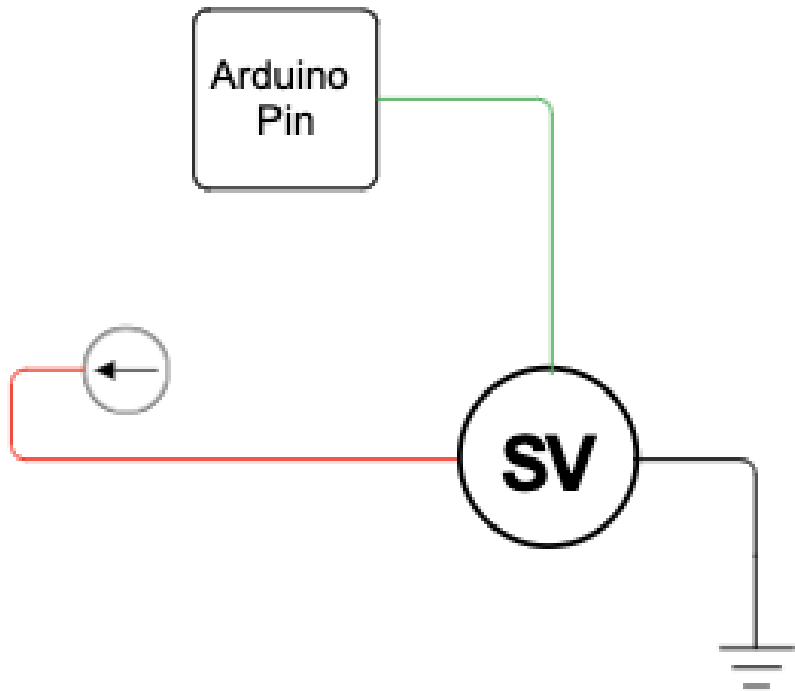
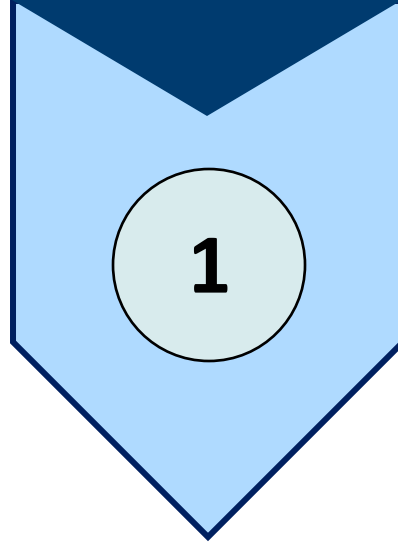

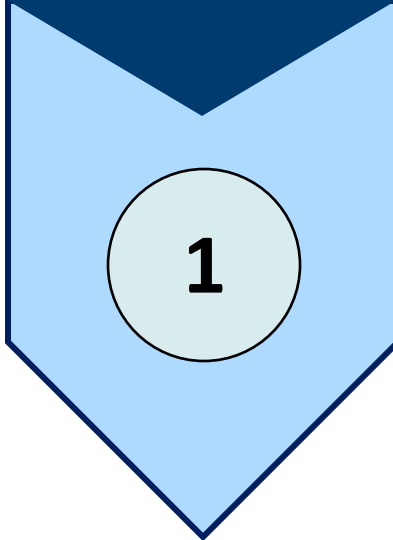

# Current Work

## Preliminary Plumbing Diagram

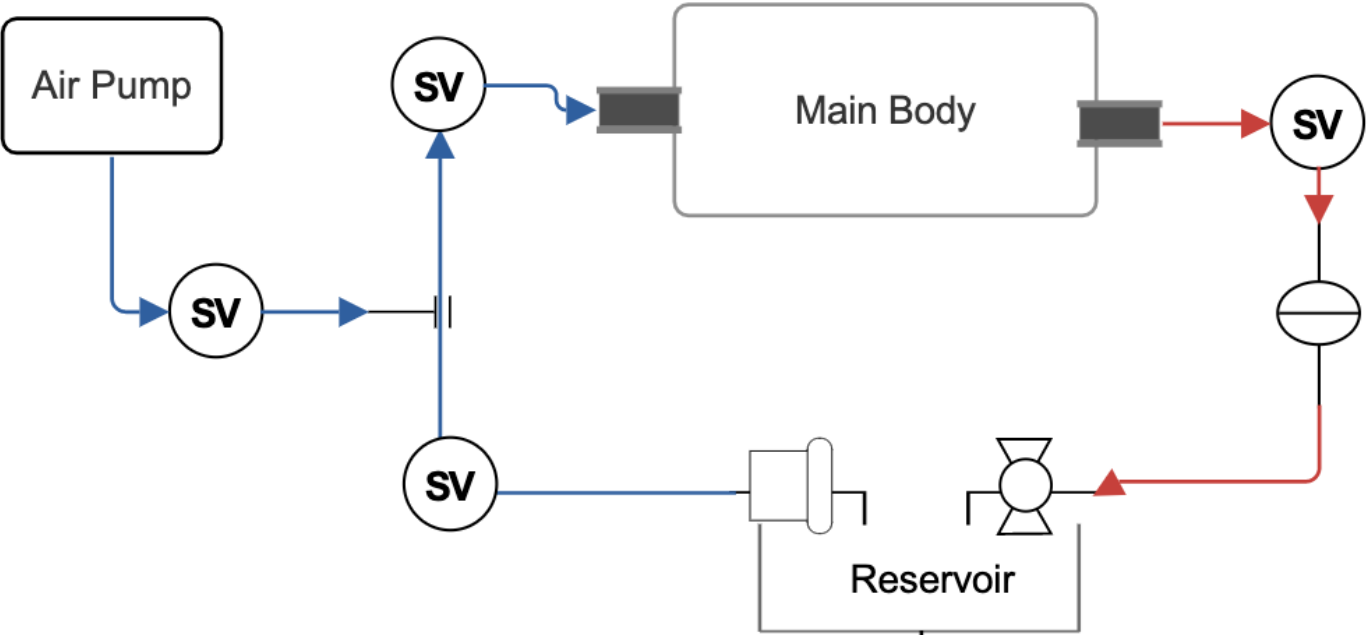

- Inlet Hose
- Outlet Hose
- Submersible Pump
- Solenoid Valve
- Hose Fitting
- Filter
- Vent Valve



# Current Work

## Preliminary Creo Design

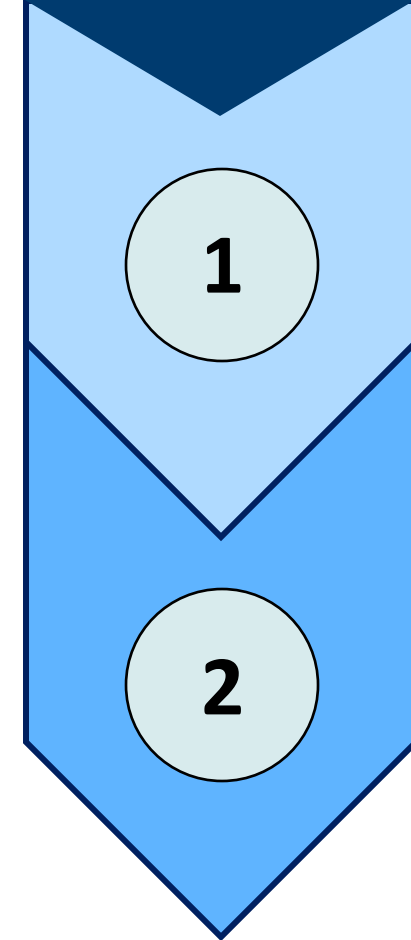
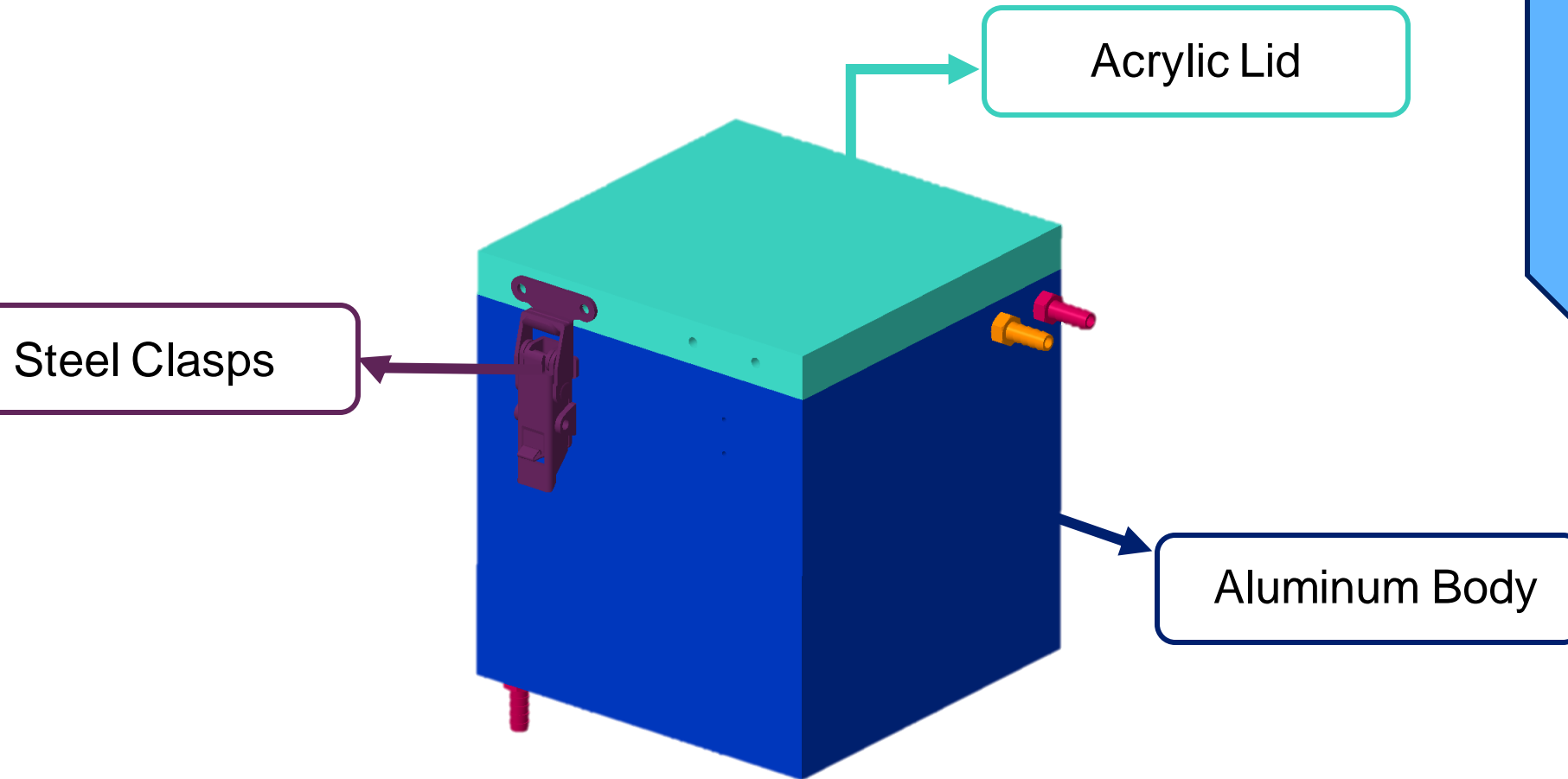

# Current Work

## Preliminary Creo Design

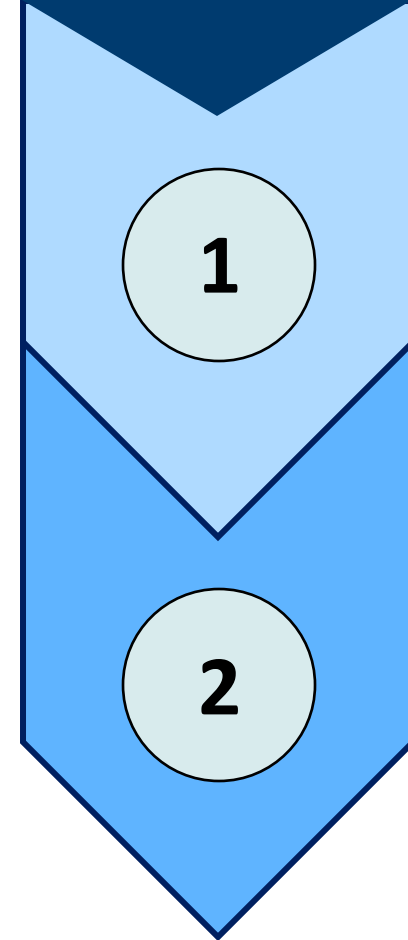
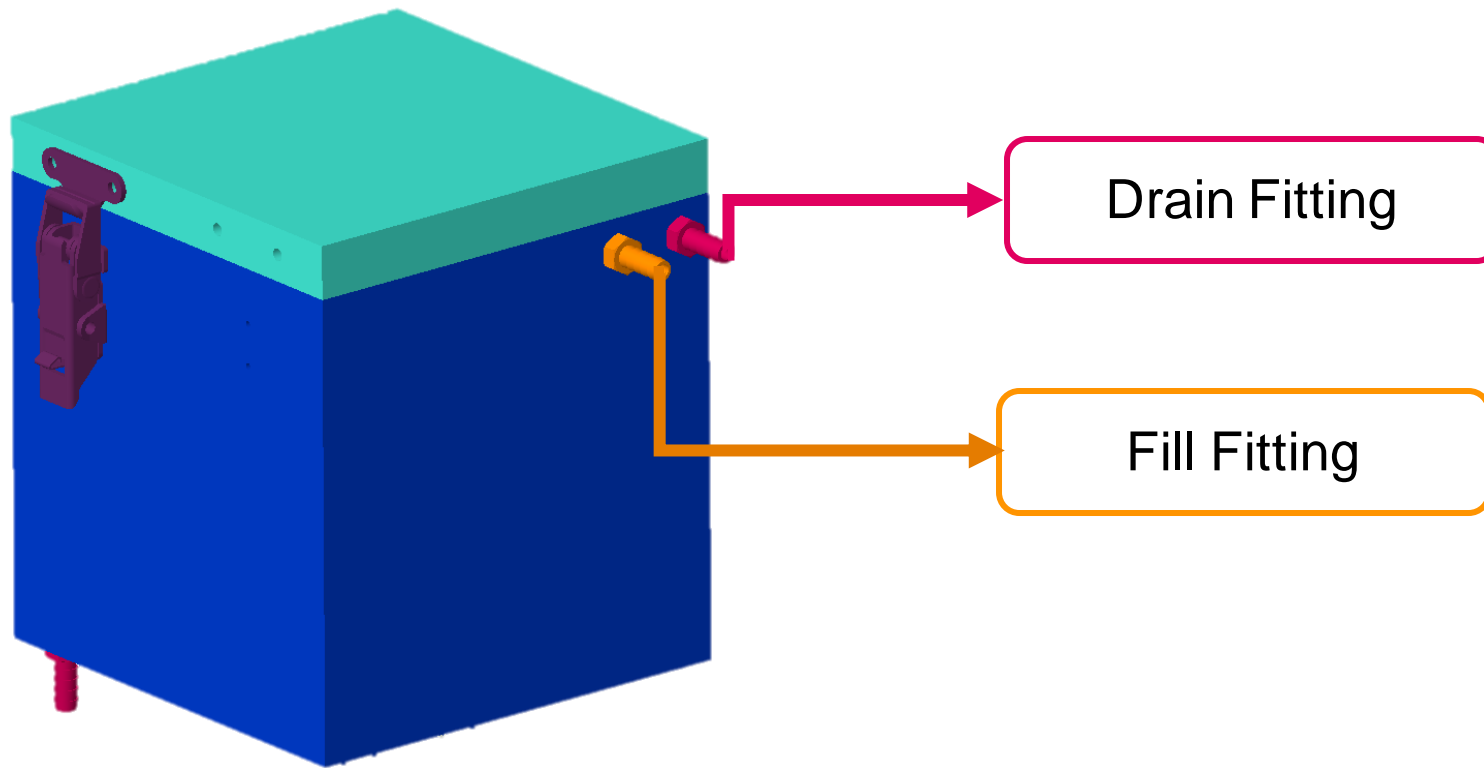

# Current Work

## Preliminary Creo Design

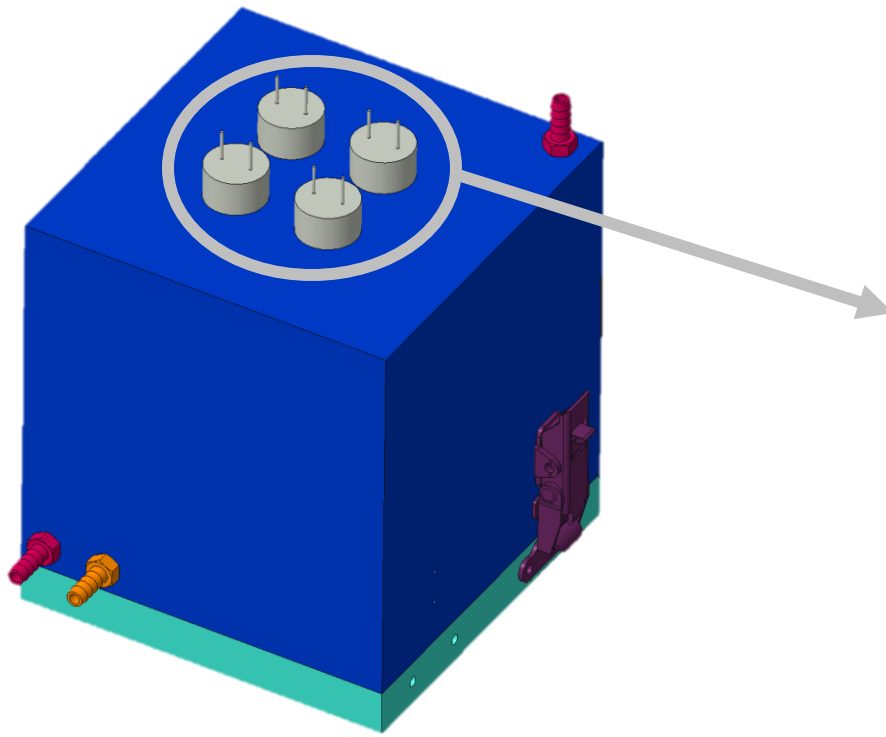

Ultrasonic Emitter

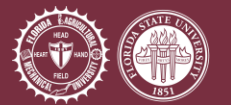
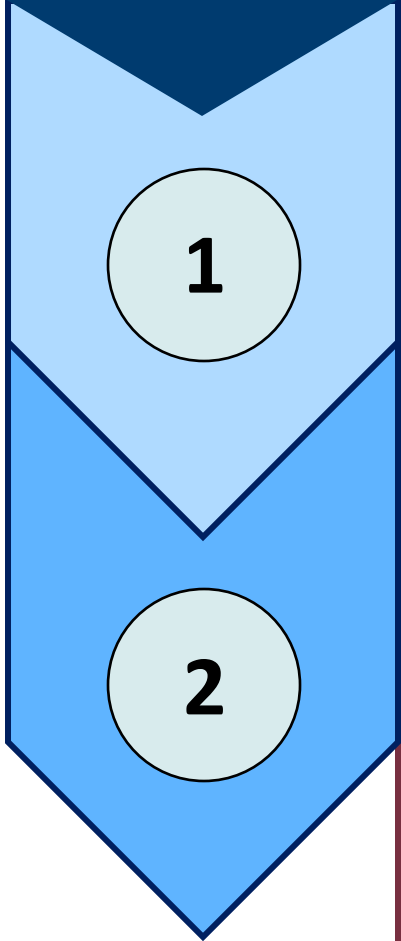

FAMU-FSU  
College of  
Engineering



# Current Work

## Bill of Materials



Ultrasonic Transducers,  
Transformers, Valves  
Ordered



Fittings, Hose,  
Aluminum  
February 3



Acrylic, Latches, Gasket  
Material  
February 18

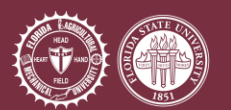
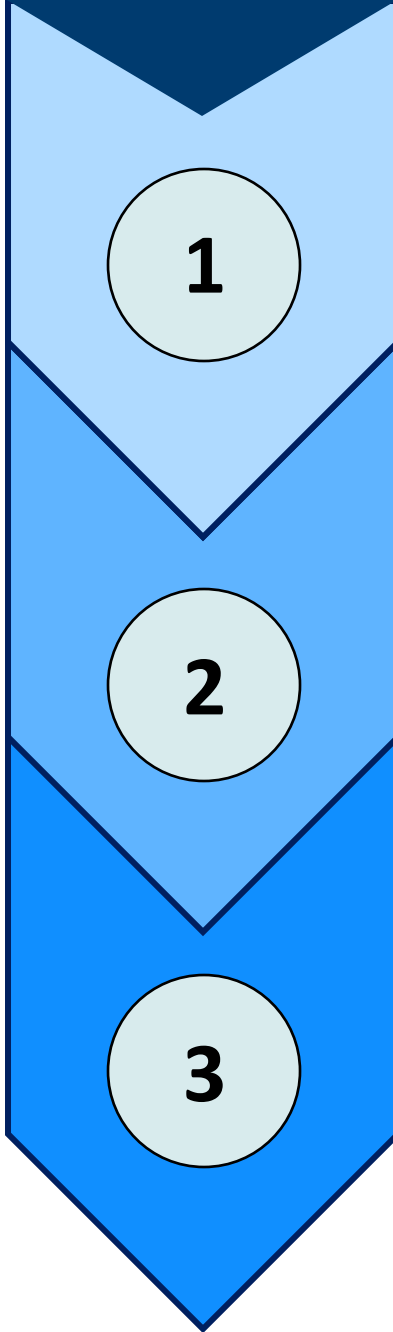

FAMU-FSU  
College of  
Engineering

# Future Work

Transformer and  
transducer testing

Assemble and test  
circuit

Prototype testing

Code Arduino to  
function with  
circuit

Assemble base  
prototype

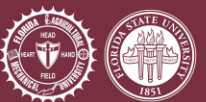

# Reference

- Justin McElderry, J.E. (2023, September 22). Intro to PRIME. NASA Marshall Space Flight Center



FAMU-FSU  
College of  
Engineering

# Questions

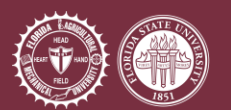

FAMU-FSU  
College of  
Engineering