



FAMU-FSU  
College of  
Engineering

# Virtual Design Review 2

## Team 510 – Danfoss IGV

11/16/2023





# Team Overview



Joseph Bechara  
*Controls Engineer*



Hunter Dabbs  
*Systems Engineer*



Tye Fountain  
*Mechanical Design  
Engineer*



Thiago Todesco  
*Manufacturing  
Engineer*



# Sponsor and Advisor



Engineering Mentor  
Bruce Barnett  
*Manufacturing Engineer*



Engineering Mentor  
William Bilbow  
*Director of Project  
Management*



Academic Advisor  
Shayne McConomy, Ph.D.  
*Teaching Faculty II*

# Objective

Develop an apparatus that tests the functionality of four different Danfoss Inlet Guide Vanes (IGVs), giving relevant data and prompting the operator with a pass or fail message.

# Danfoss

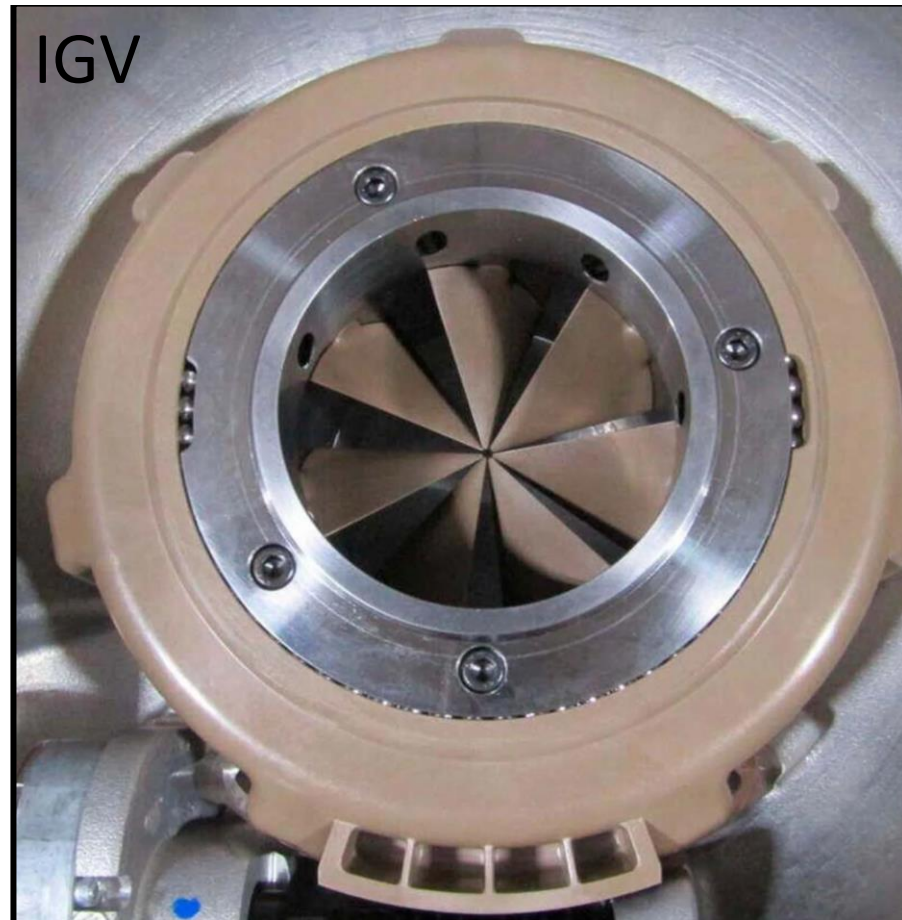

# Assumptions



Responsibility for  
all Documentation



Test fixture fits  
into existing  
workstation

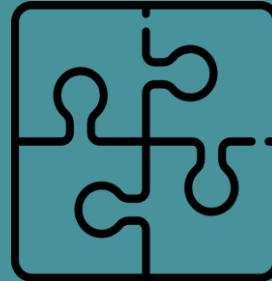

Production ready  
IGV



Operators able to  
lift 50 pounds

# Key Goals

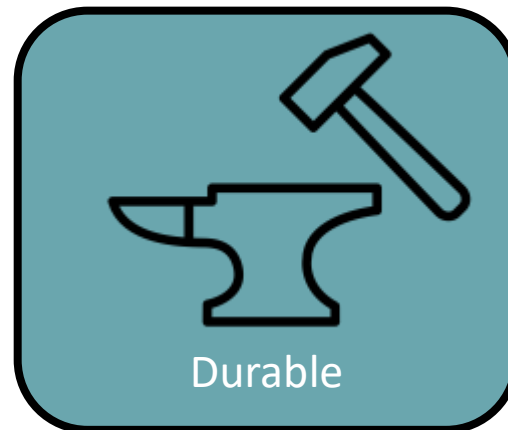
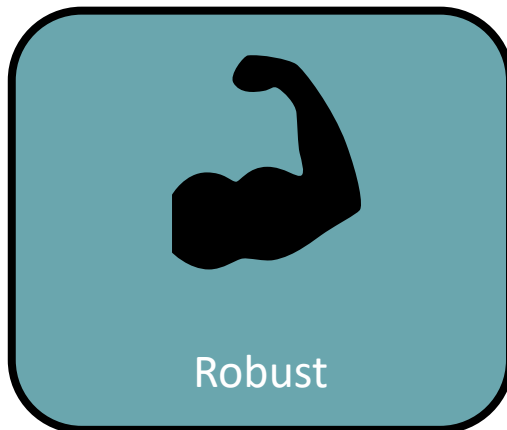
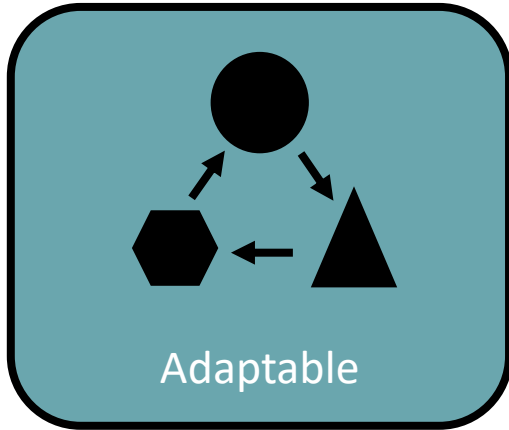

# Functional Resolution

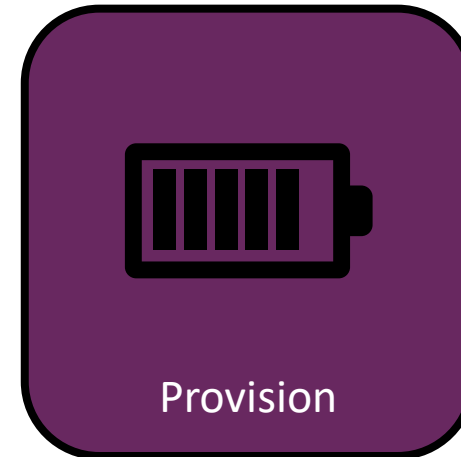
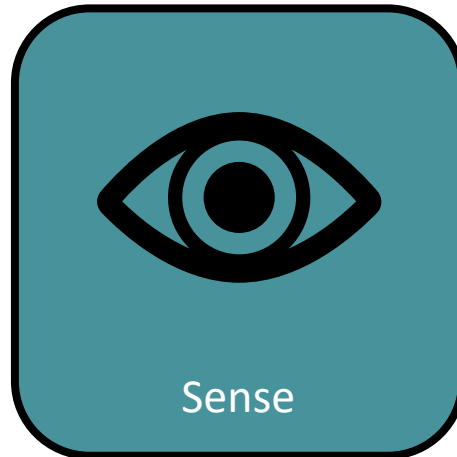
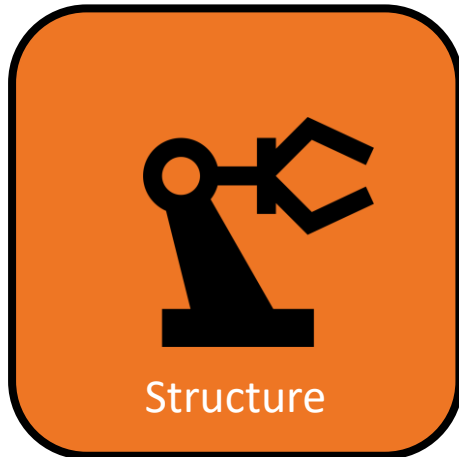
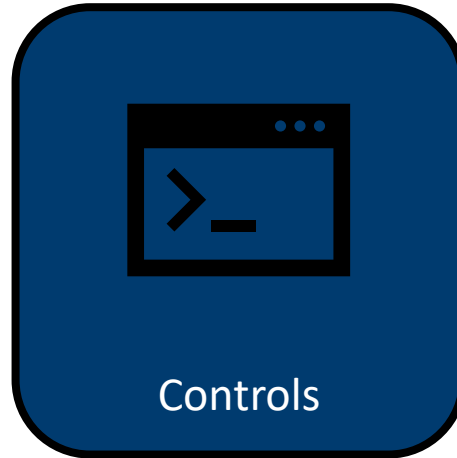

# Targets and Metrics

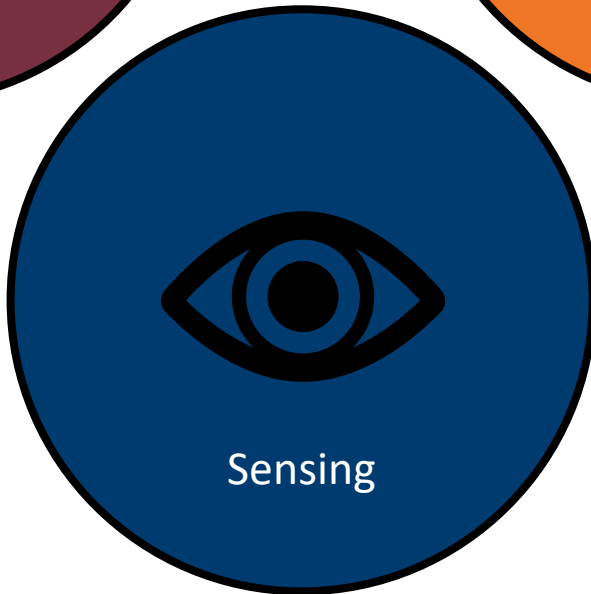
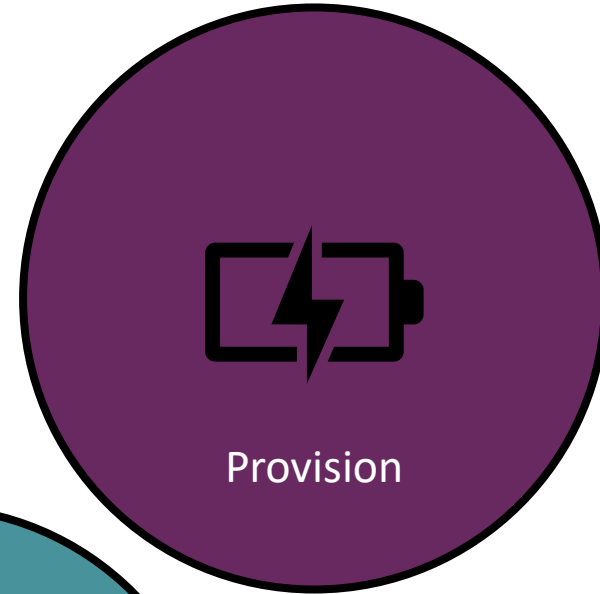
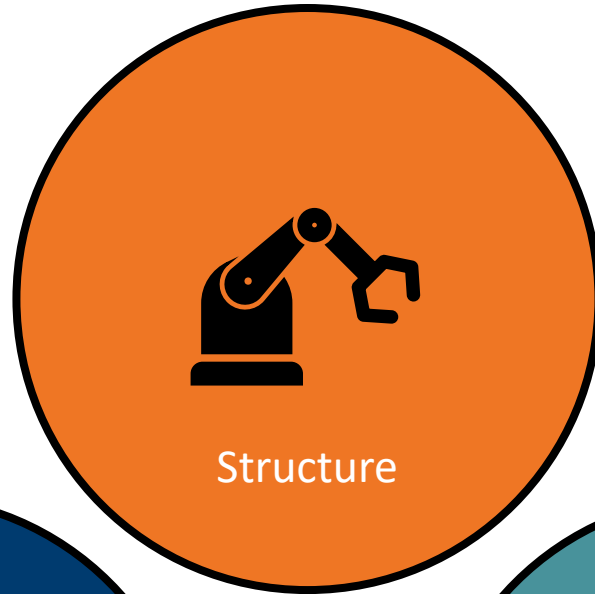
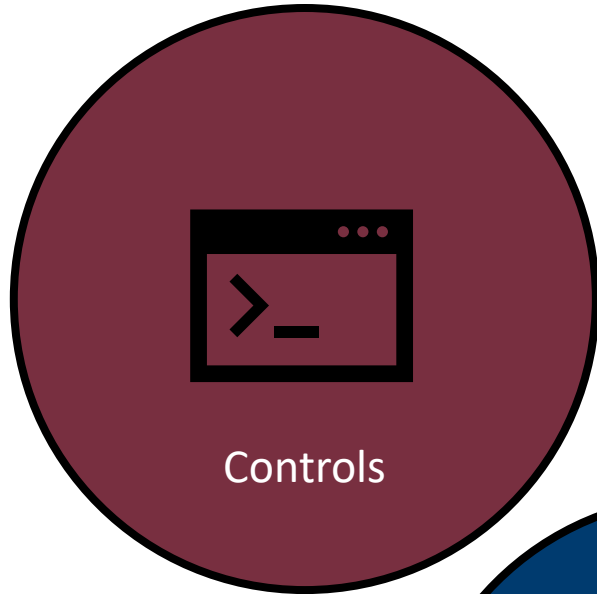



# Targets and Metrics

Torque compliance

Determining IGV model

Tracking movement of IGV blades

Tracking test state

Tracking ball indicator location

Read and process angle of IGV blades

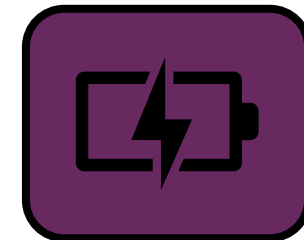
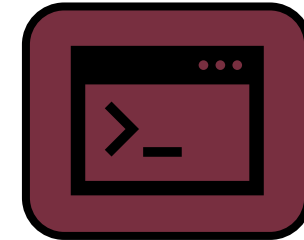
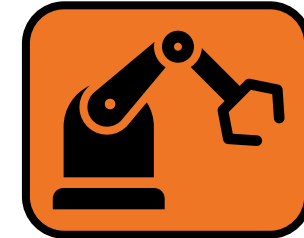
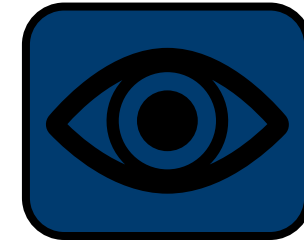

# Targets and Metrics

Start/Stop test

Open/Close IGV blades

Monitor torque output of the electric motor

Restricts IGV blades

Store test data

Read and process ball indicator location

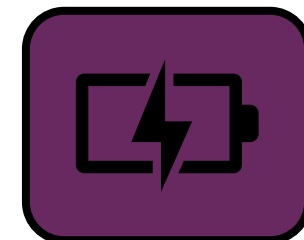
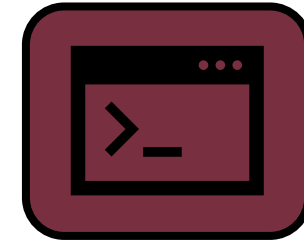
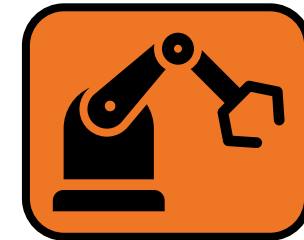
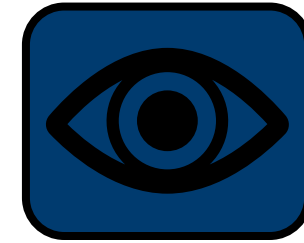

# Targets and Metrics

Supplies power to  
IGV motor

Indicate results to  
user

Resist an impact  
force of 10 Newtons

Supplies power to  
test system

Receive inputs from  
user

Prevent tipping with  
a max force of 10  
Newtons at the top

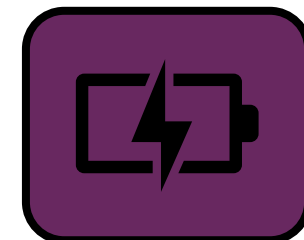
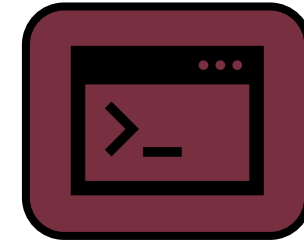
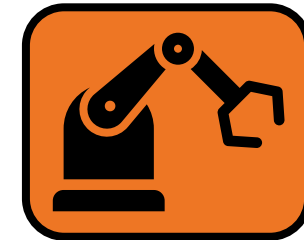
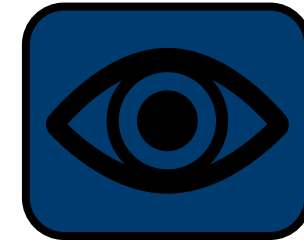

# Concept Generation

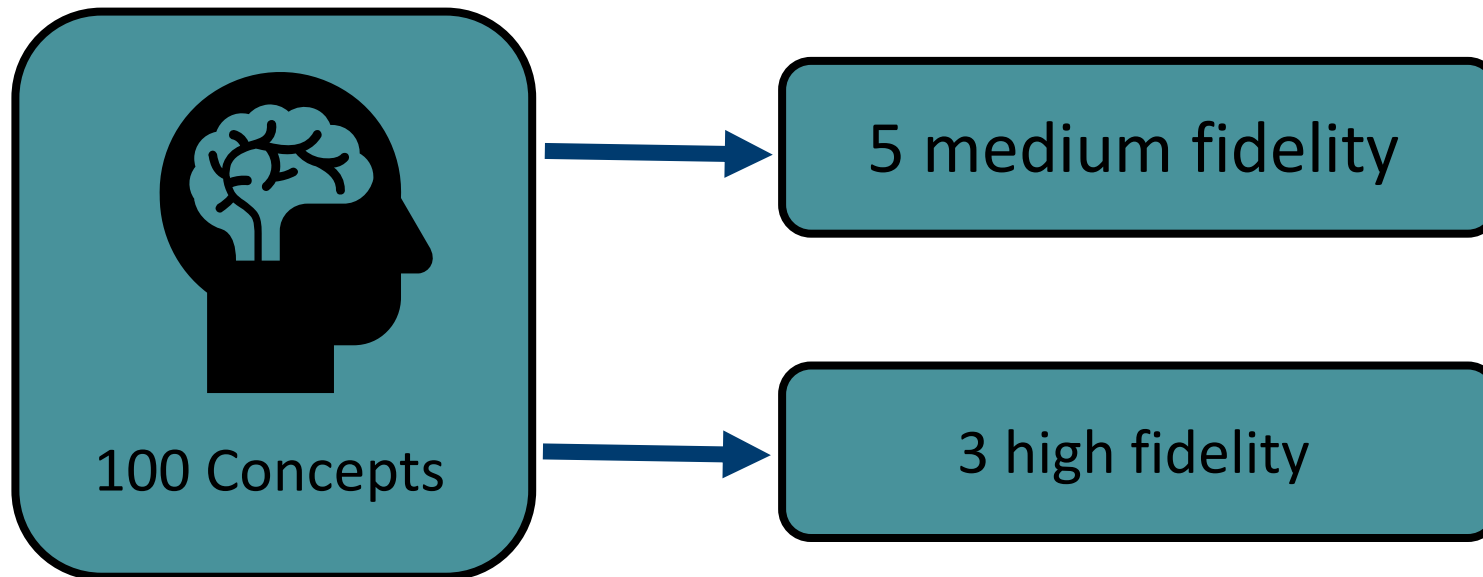



# Medium Fidelity Concepts

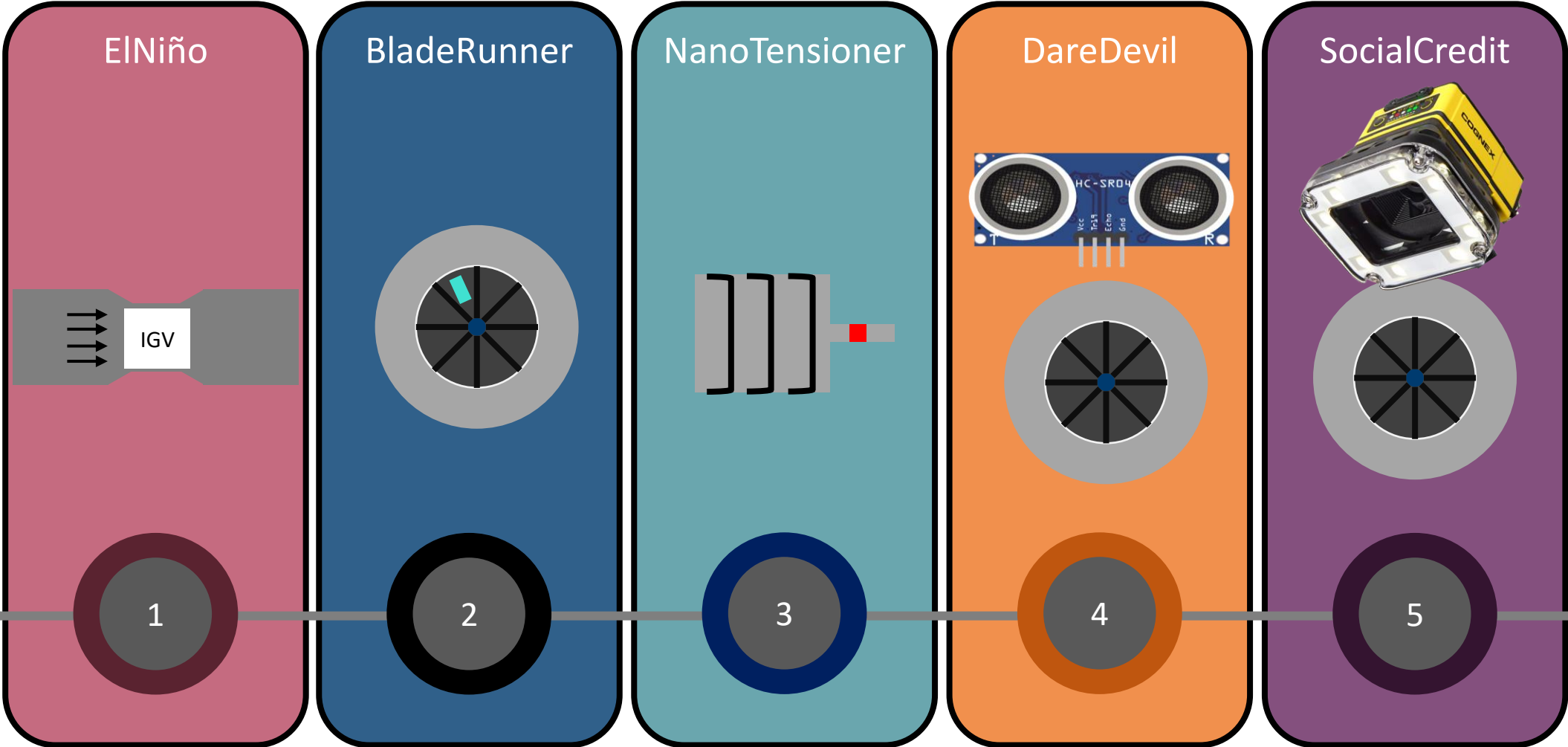

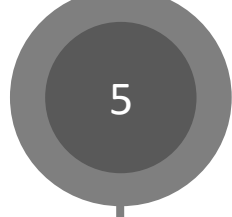
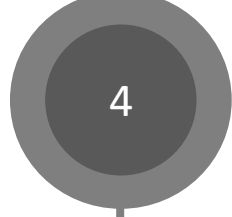
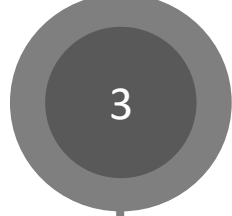
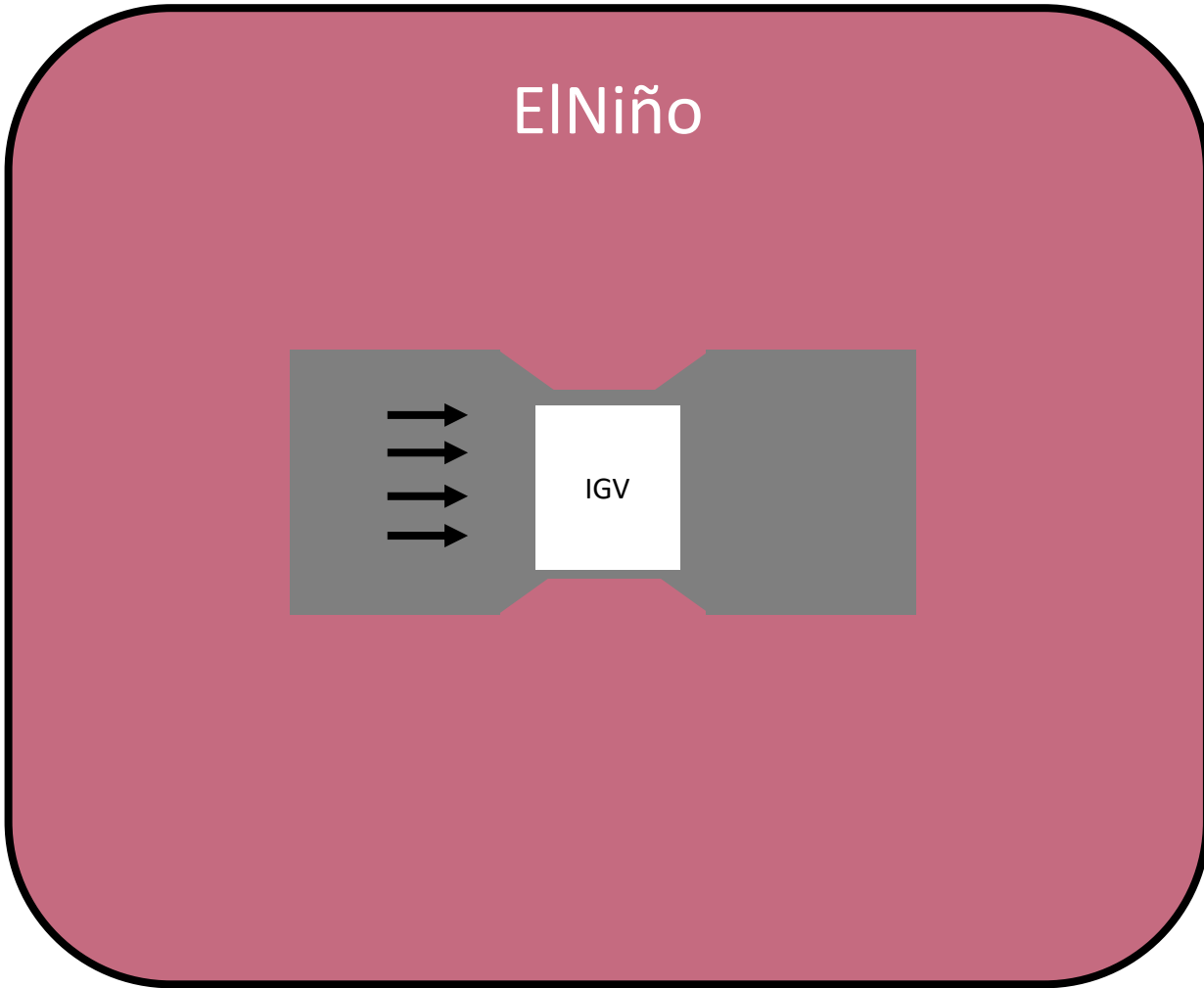

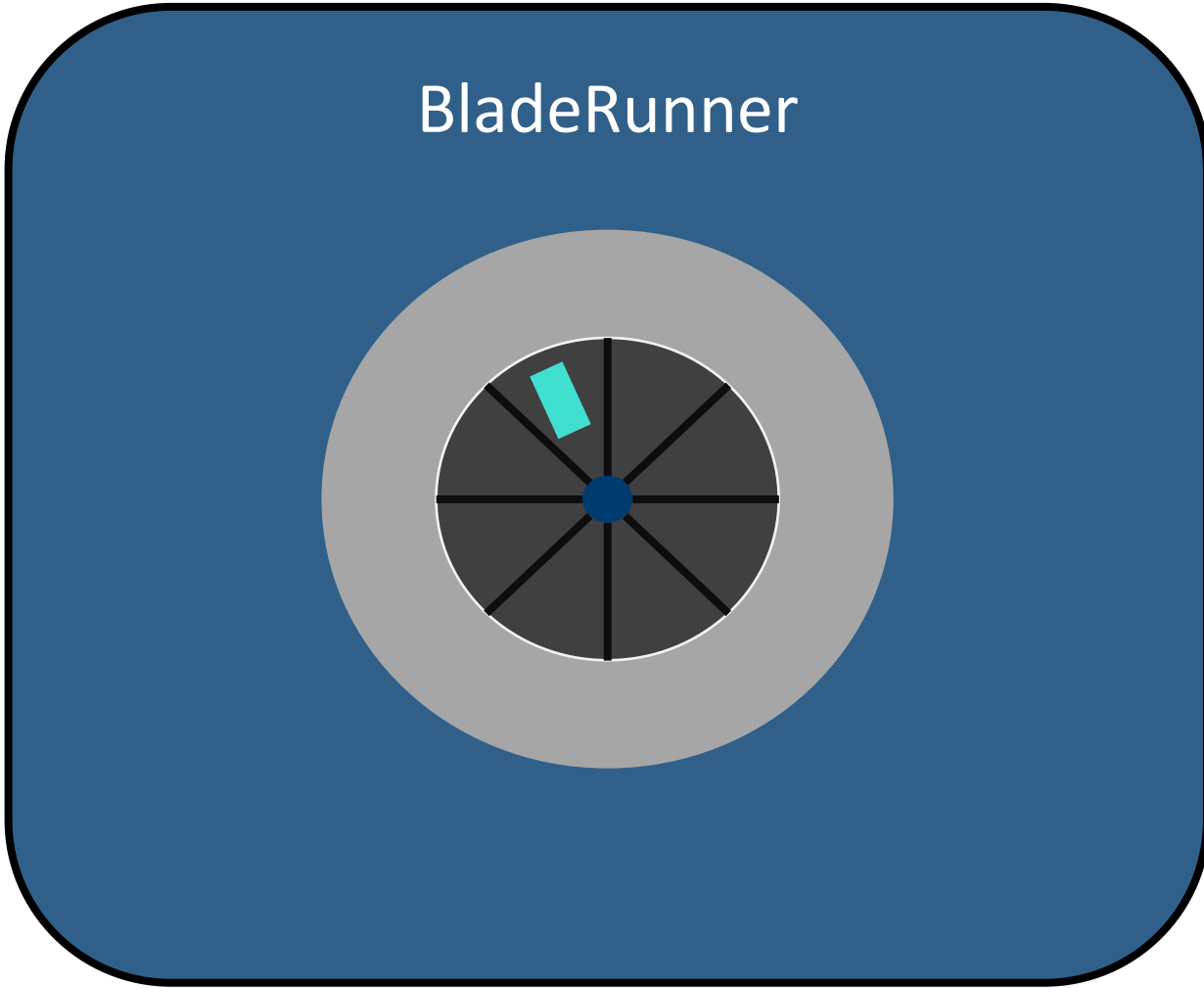

- 1
- 2
- 3
- 4
- 5

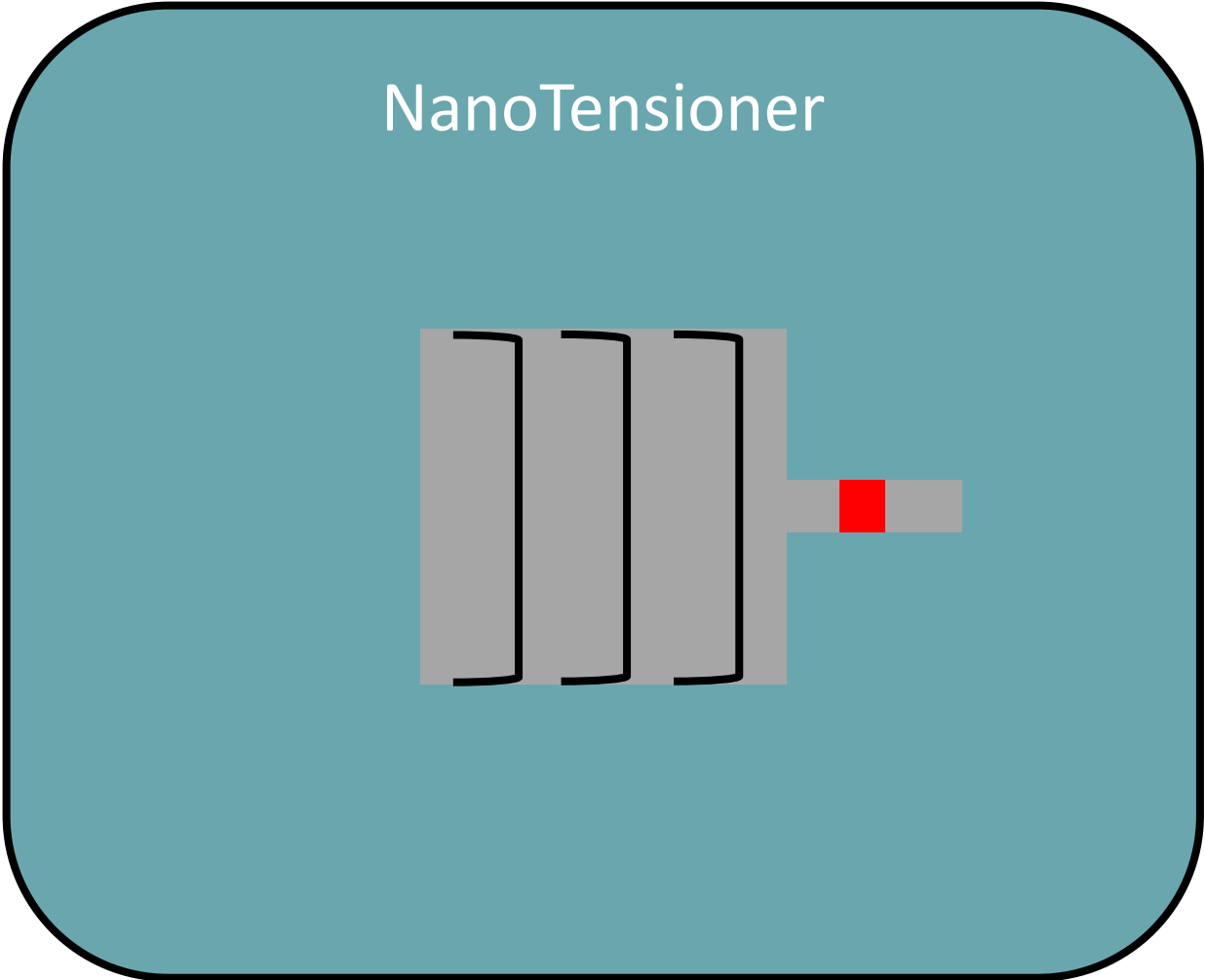



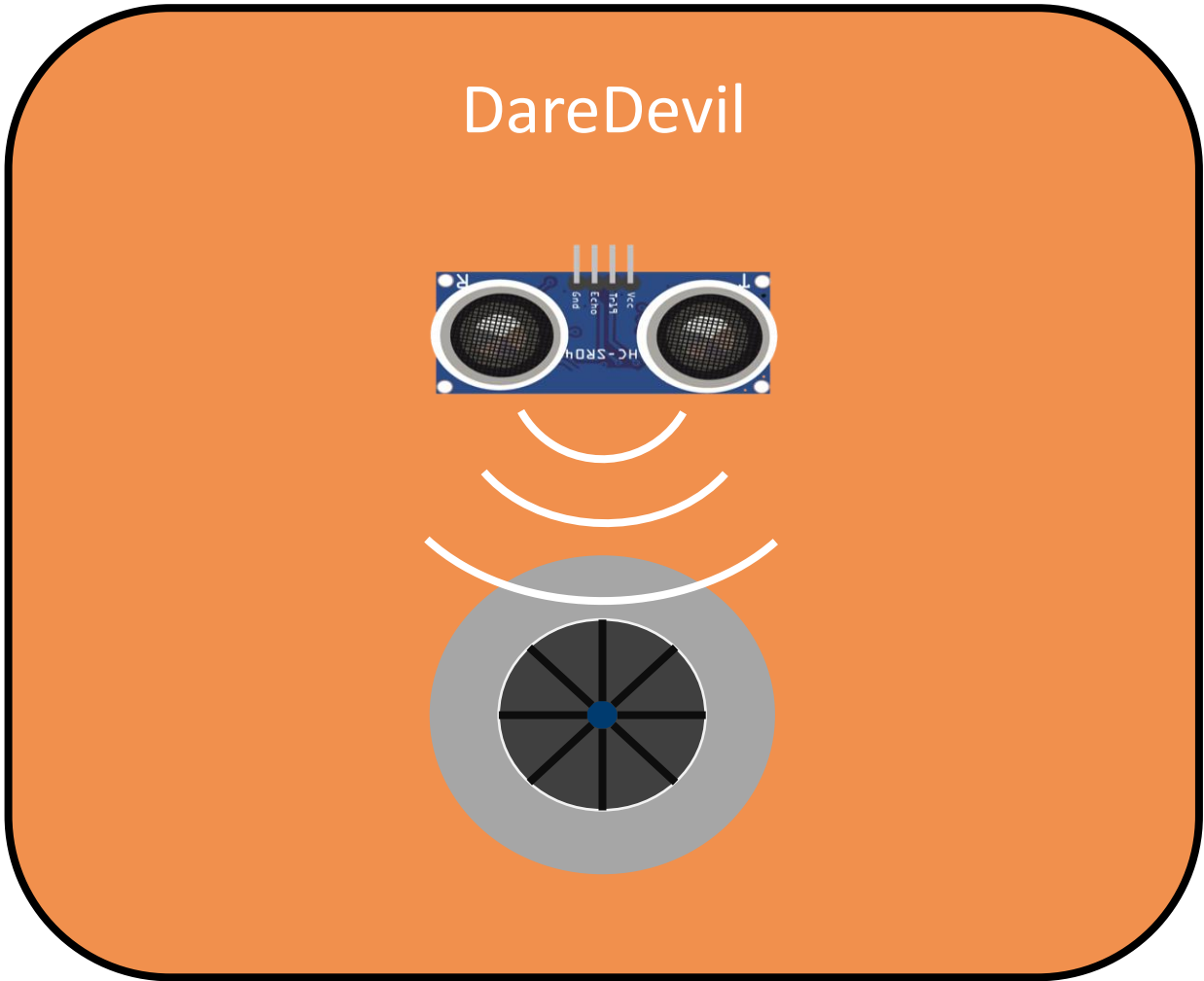

- 1
- 2
- 3
- 4
- 5



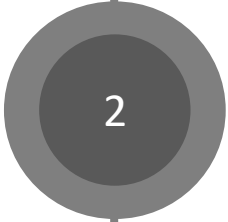
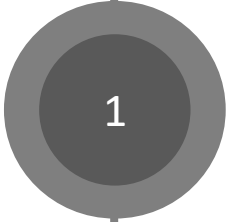

# High Fidelity Concepts

MysteryBox

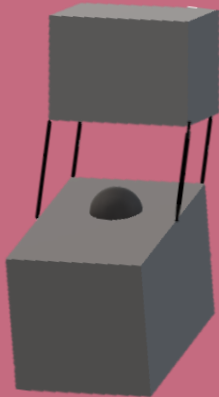

1

ButterCookie

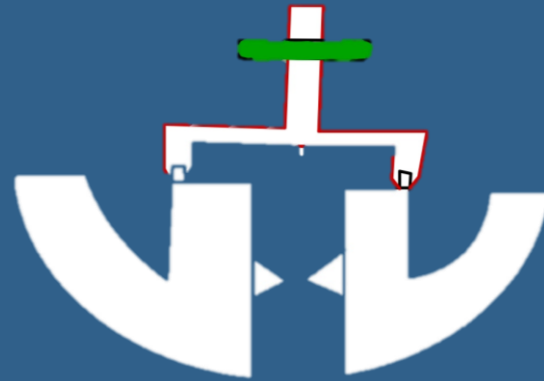

2

MegaMaid

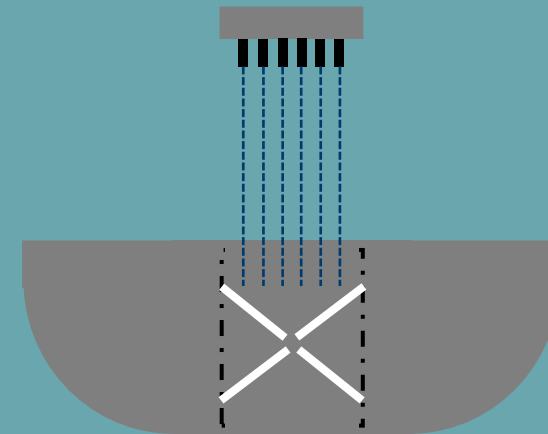

3

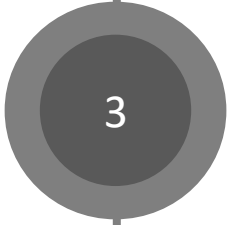
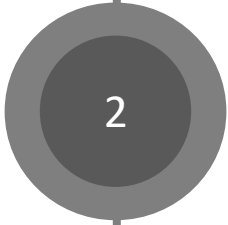
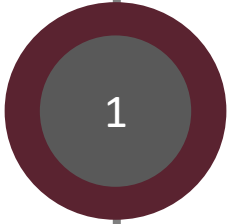
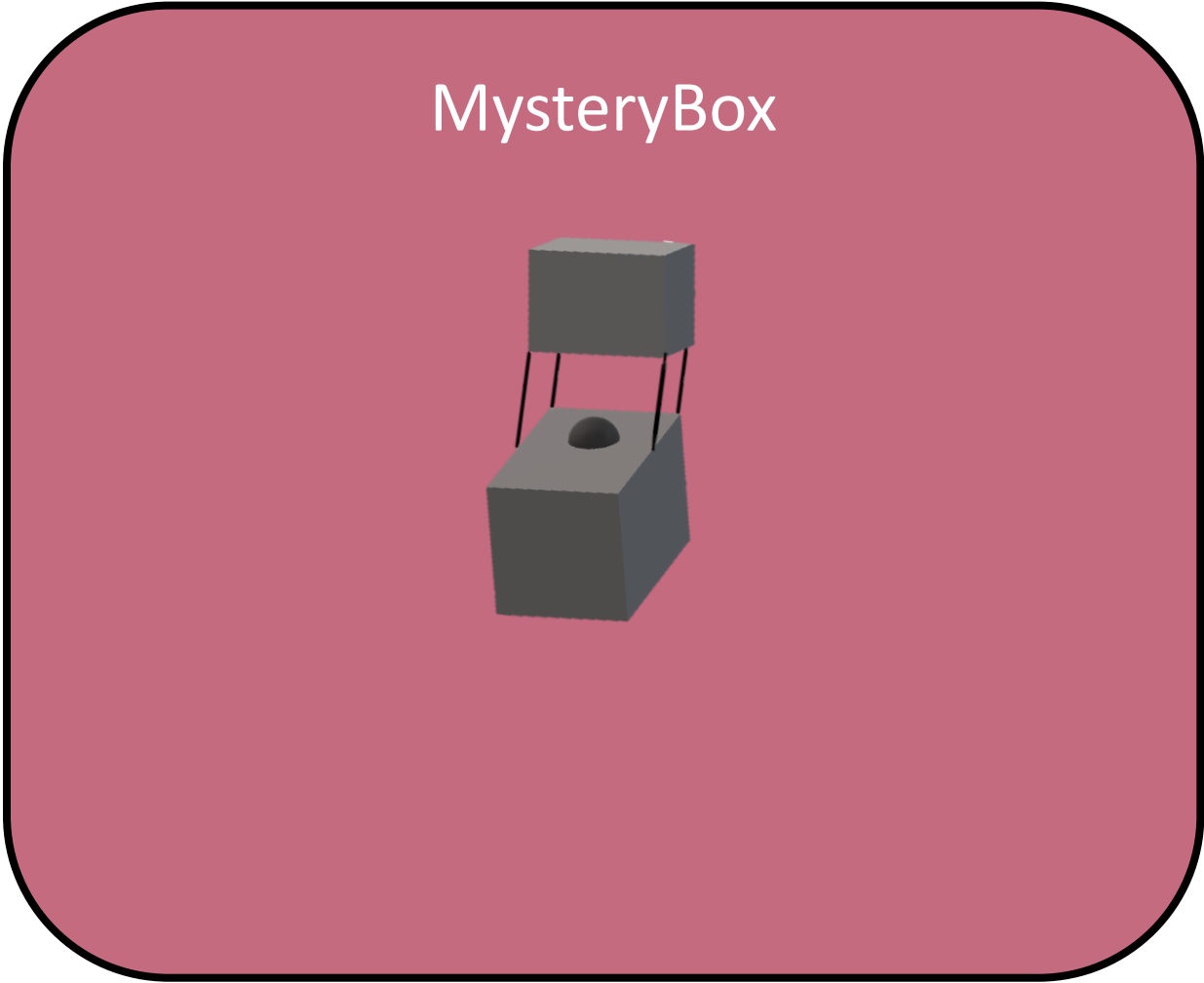



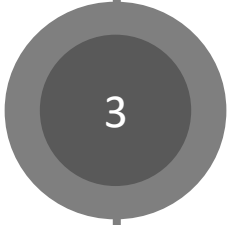
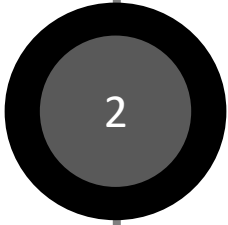
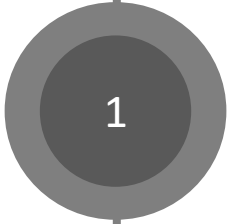
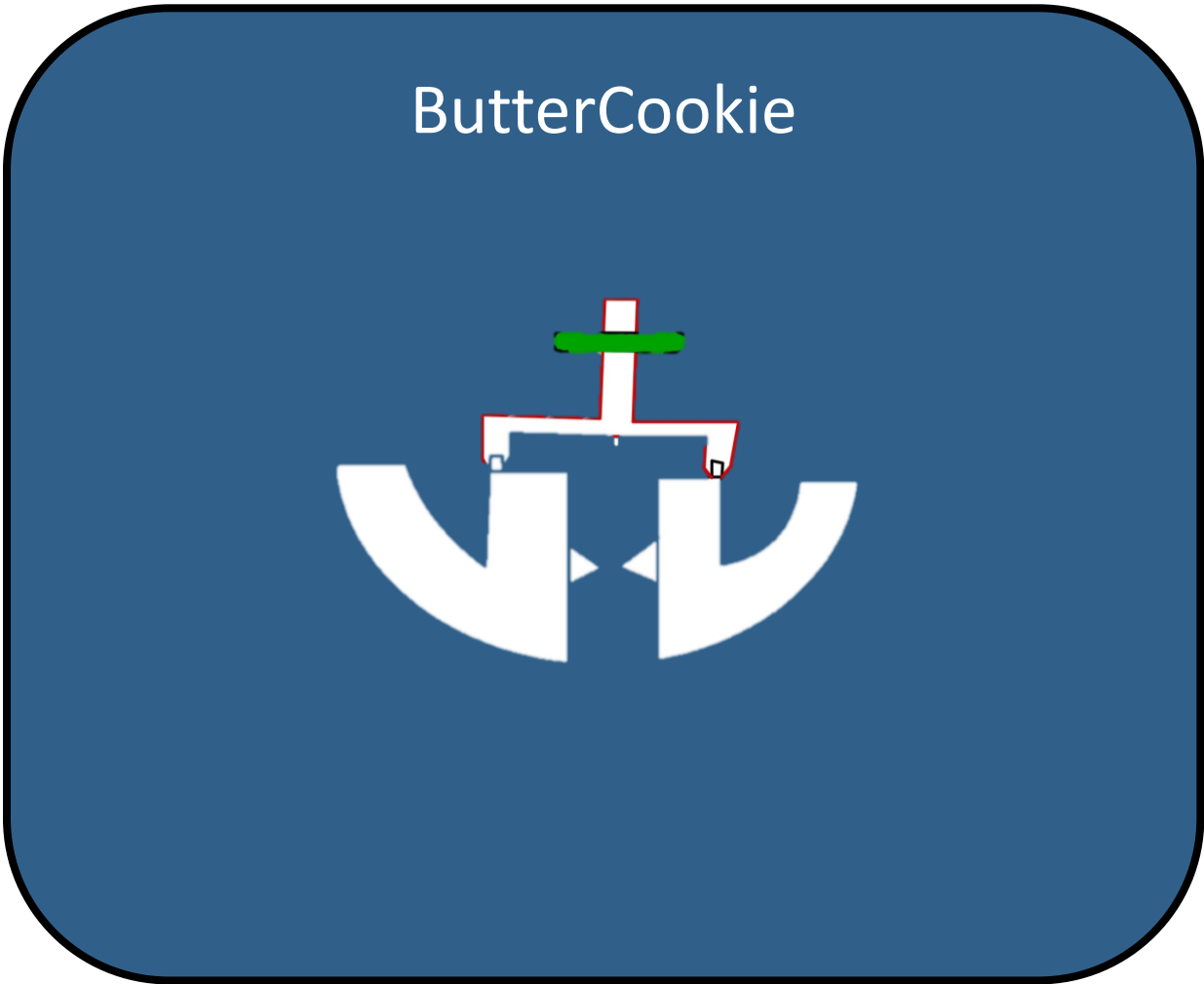

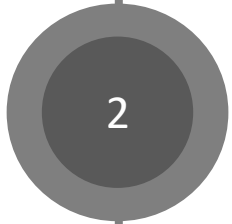
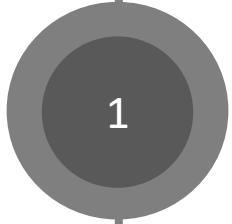
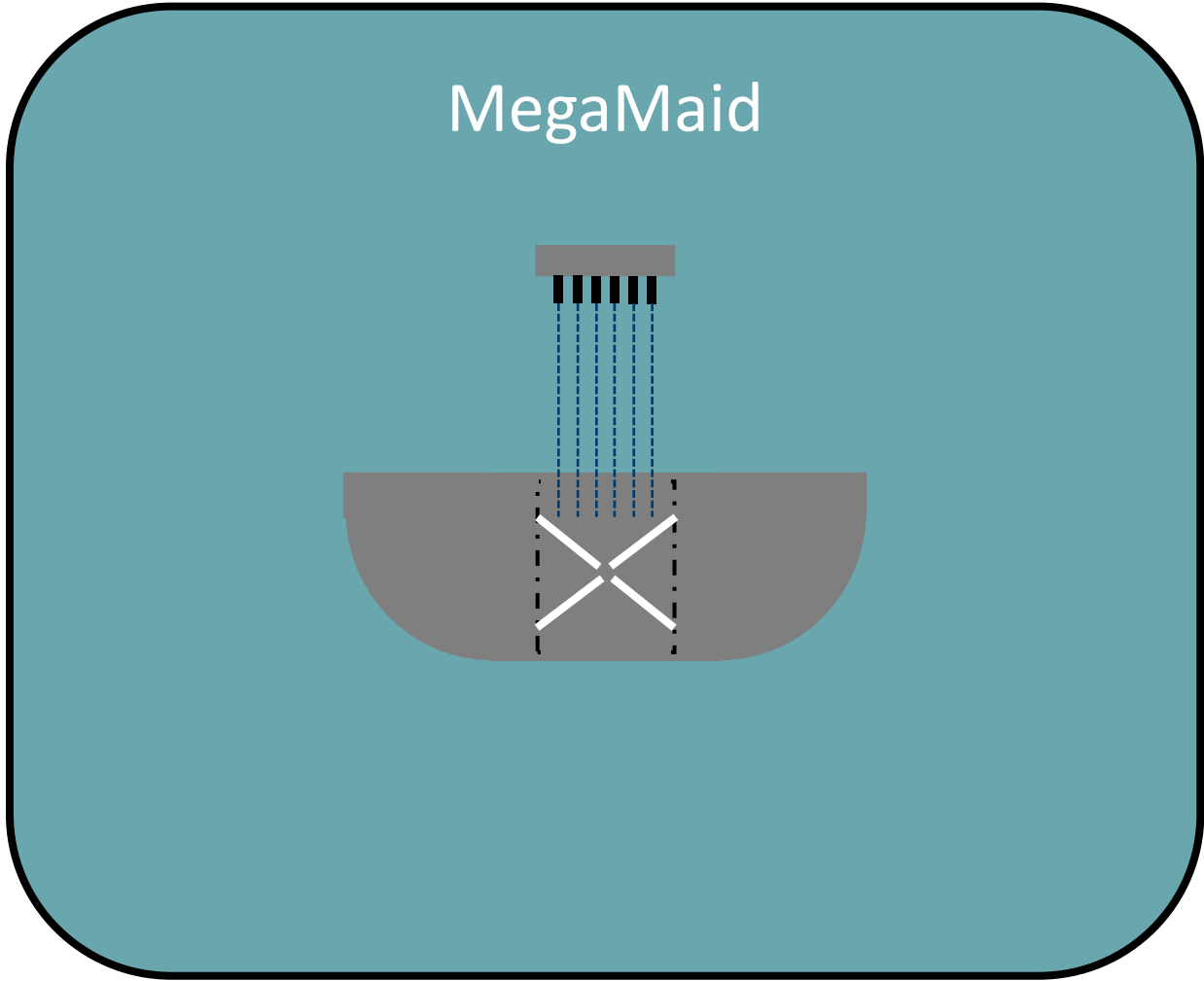

# House of Quality

Collects test data



Provides indication



Fixture does not tip over

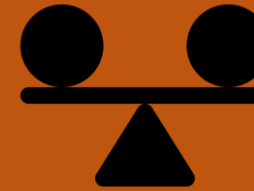

Store test data



Supplies power to test system

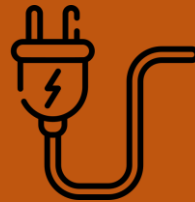

Can be supported by workstation

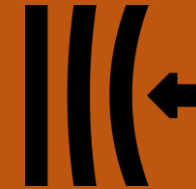

# Pugh Chart

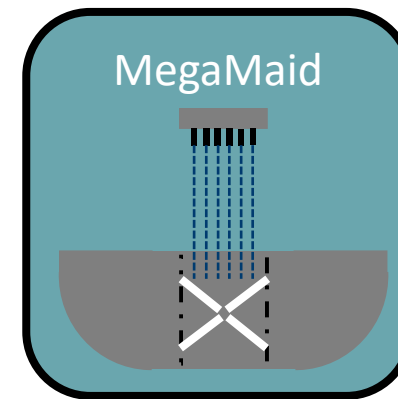
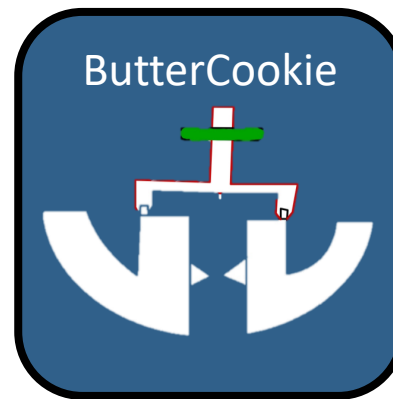
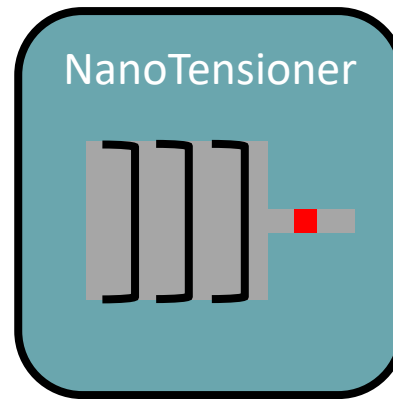
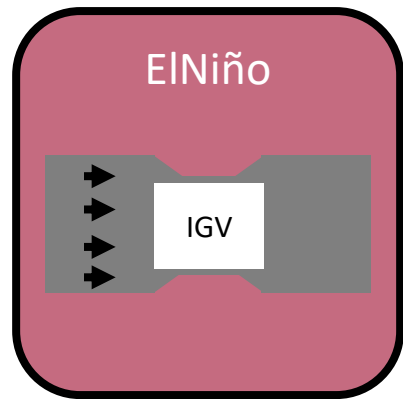

# Pugh Chart: First Round

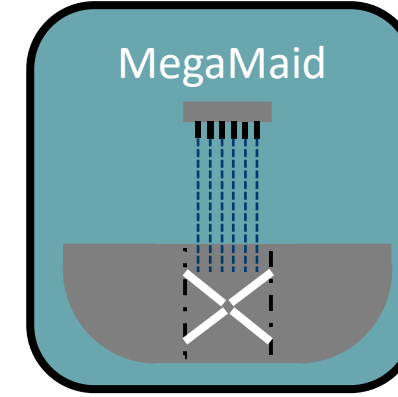
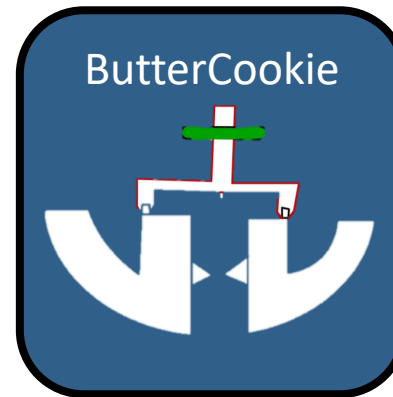
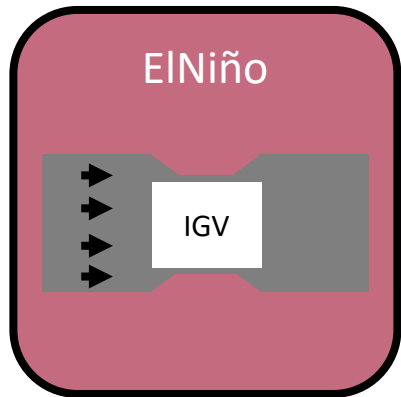

# Pugh Chart: Second Round

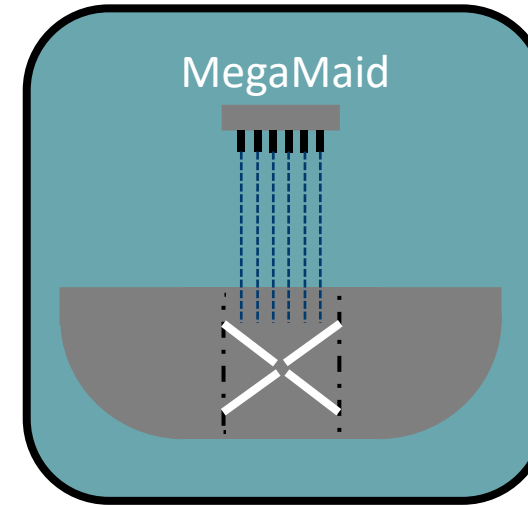
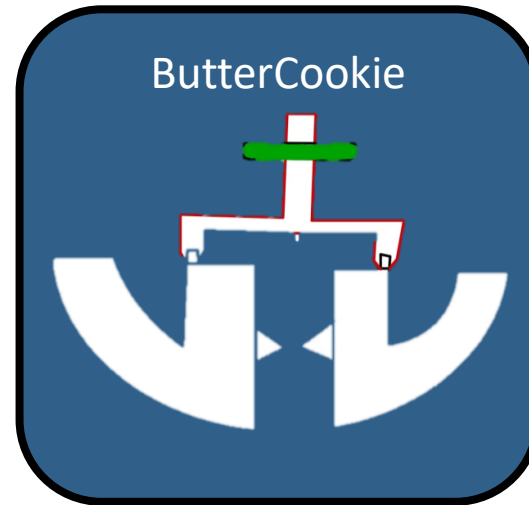

# Analytical Hierarchy Process

<b>Concept</b>	<b>Alternative Value</b>
MysteryBox	0.235
ButterCookie	0.333
MegaMaid	0.432

# Final Selection

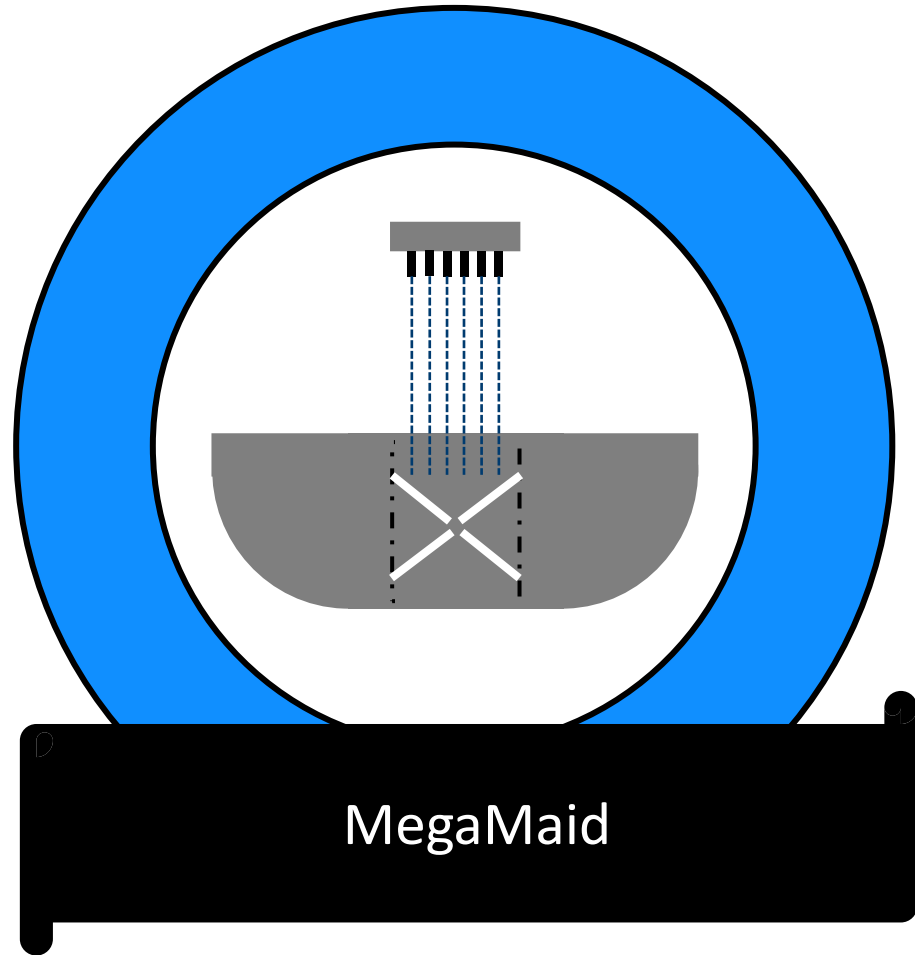

Stable design

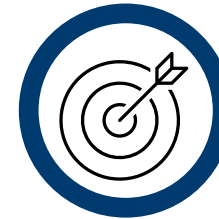

Accurate and precise

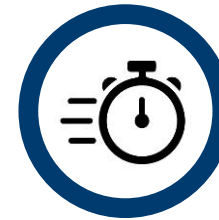

Fast



Durable



# Future Work

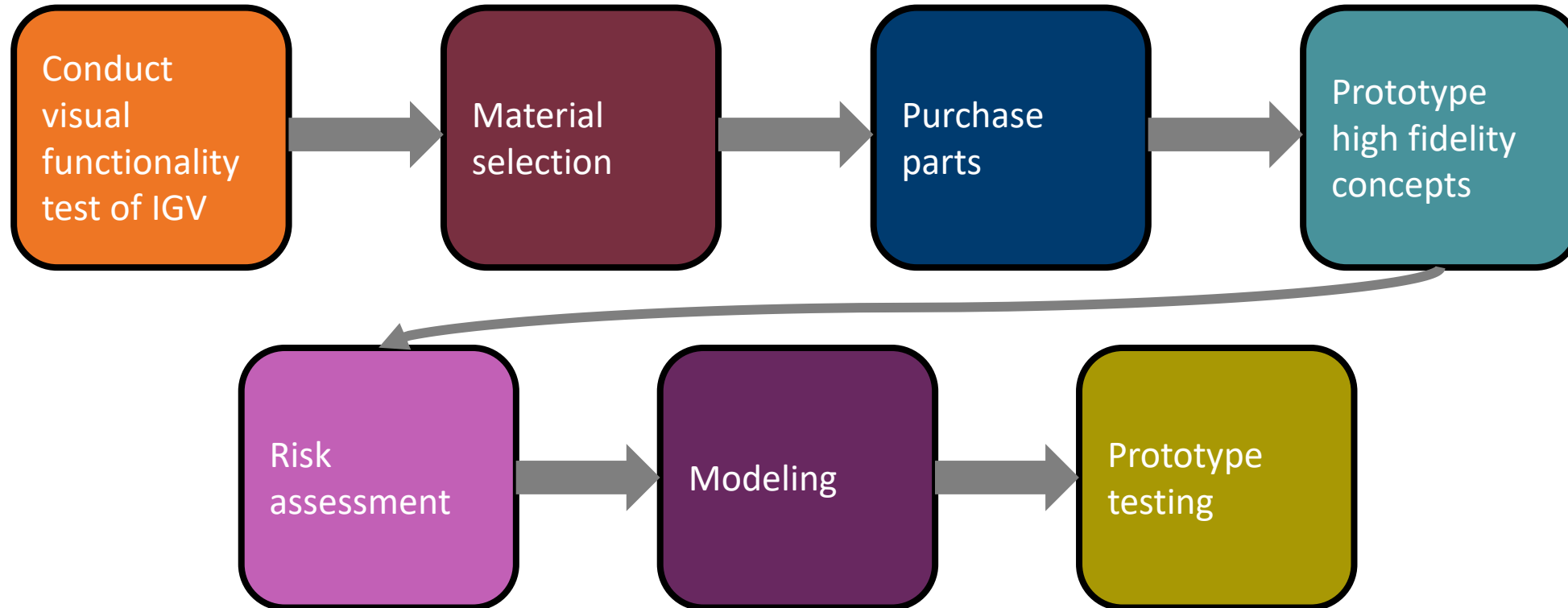

# Questions

