

MICROGRAVITY MACHINE

Virtual Design Review 2



TEAM 511



Samuel Duval

Propulsion Engineer



Pedro Siman

Recovery Engineer



John
Tietsworth

Controls Engineer

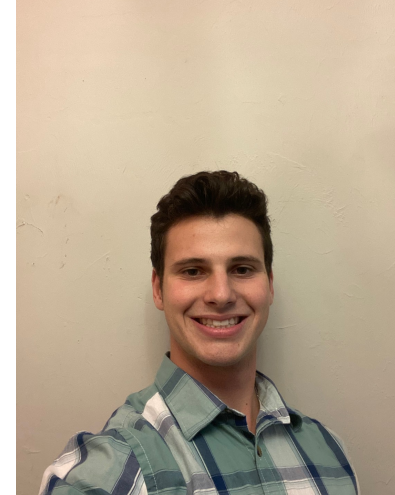

Thomas Lenz

Test & Systems Engineer



Collin Gainer

Aero Design Engineer

John Tietsworth

Sponsor and Advisor



Dr. Mohd
Yousuf Ali

**FAMU-FSU
College of
Engineering**



Dr. Shayne
McConomy

**FAMU-FSU
College of
Engineering**



Mike Conroy

**Florida Space
Group
Consortium**

John Tietsworth

Project Objective

The objective of the project is to design a reproducible system that can be dropped, achieve microgravity during its descent, and be safely recovered for reuse.

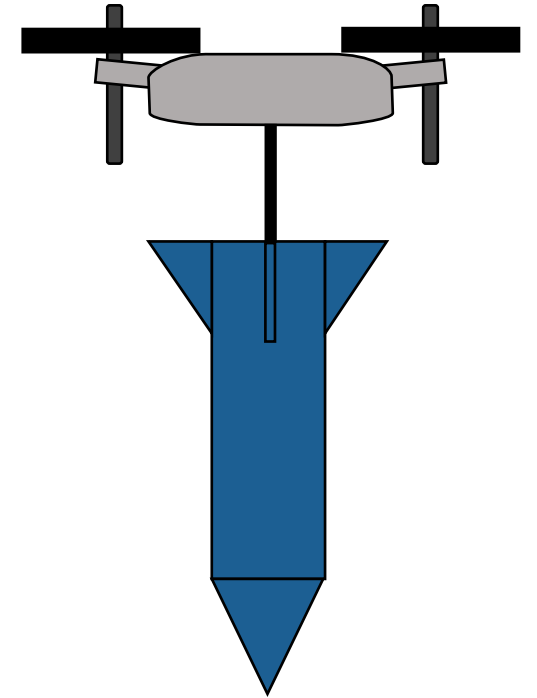

John Tietsworth

What is Microgravity?

$$\vec{F}_{Specific} = \frac{\sum \vec{F}_{nongravitational}}{m} \approx 0 \frac{m}{s^2}$$

What does an
accelerometer measure?

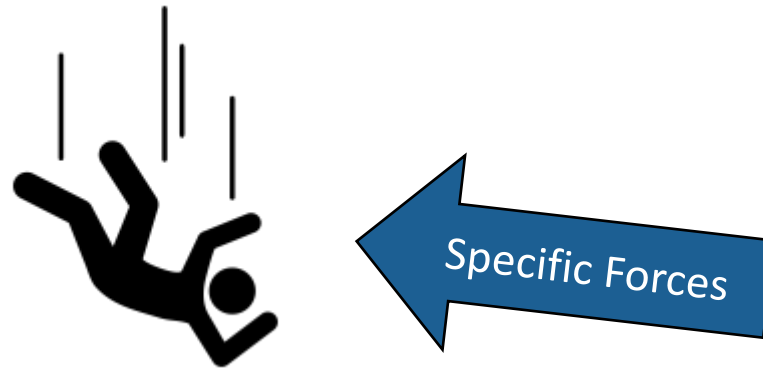

John Tietsworth

Achieving Freefall

$$\vec{F}_{Specific} = \vec{F}_{Propulsive} - \vec{F}_{Drag} \approx 0 \frac{m}{s^2}$$

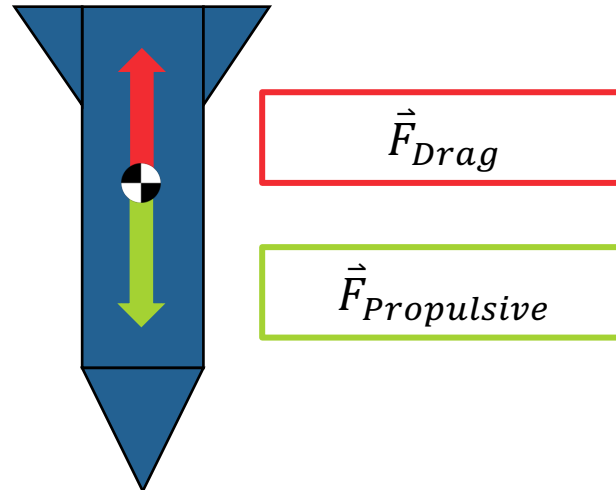

John Tietsworth

Arresting System

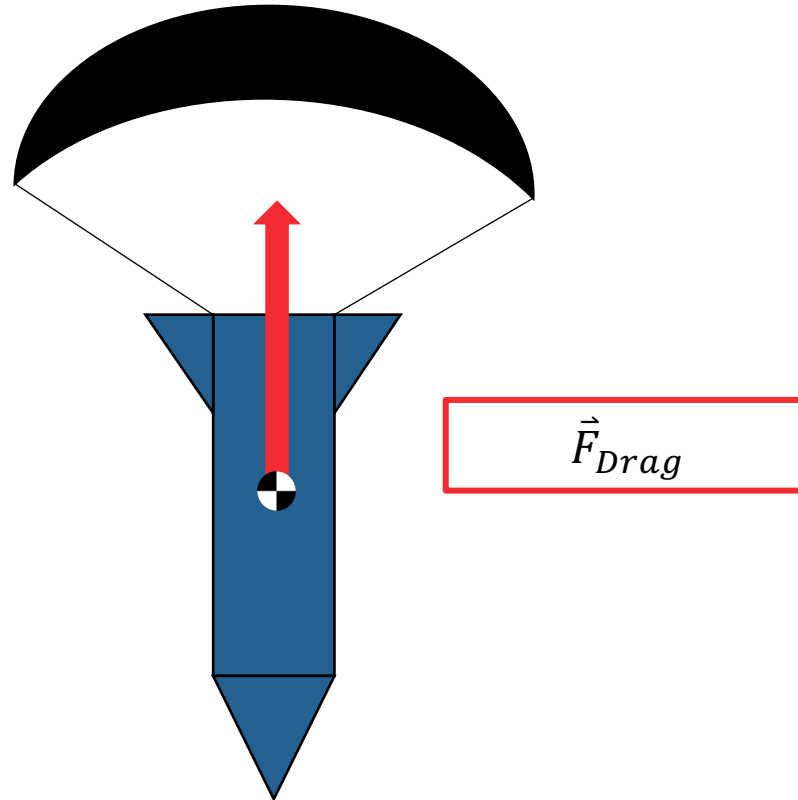

John Tietsworth

Competition Day

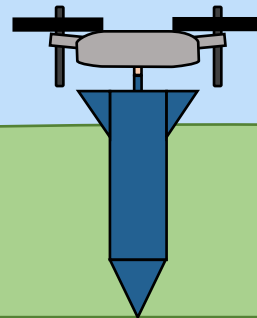

John Tietsworth

Competition Day

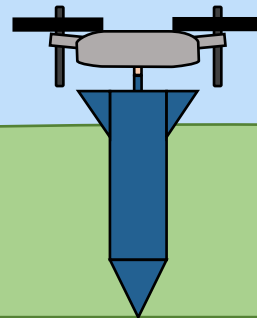

John Tietsworth

Competition Day

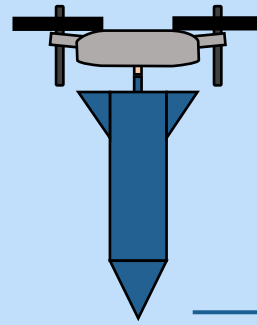

900 ft (275m)

John Tietsworth

Competition Day

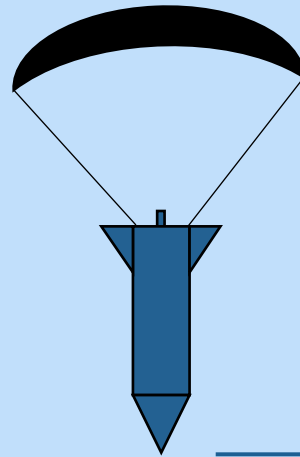
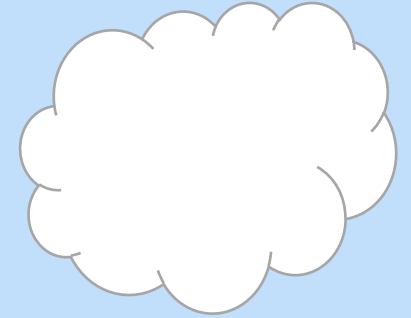
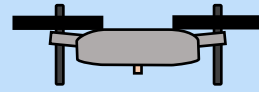

~650 ft (200m)

John Tietsworth

Assumptions

Vehicle's path
is clear of
obstacles

Tested in
standard earth
atmosphere

Drag negligible
for initial 0.5
seconds of free
fall

Weather
conditions
aren't of
concern

John Tietsworth

Key Goals



Microgravity



Recoverable

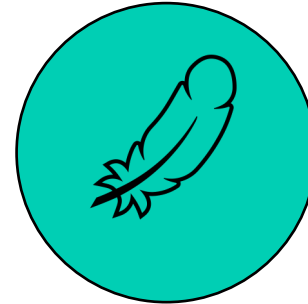

Meet weight requirements

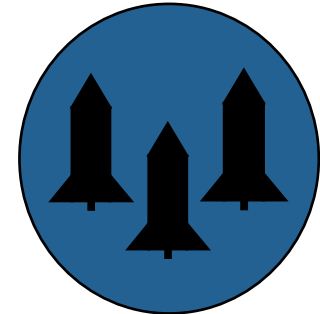

Reproduceable

John Tietsworth

Customer Needs



Design needs to be recoverable



The device can't use explosives



Machine must be less than 10 kg



The machine must achieve microgravity for 3-4 seconds



Machine must house a 3U CubeSat sized payload of dimensions 100x100x300 mm

John Tietsworth

Functional Decomposition

Recap

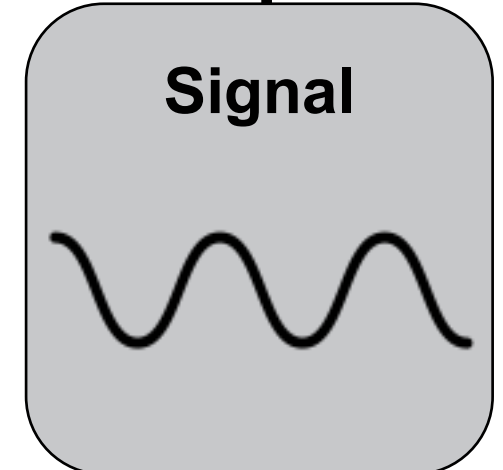
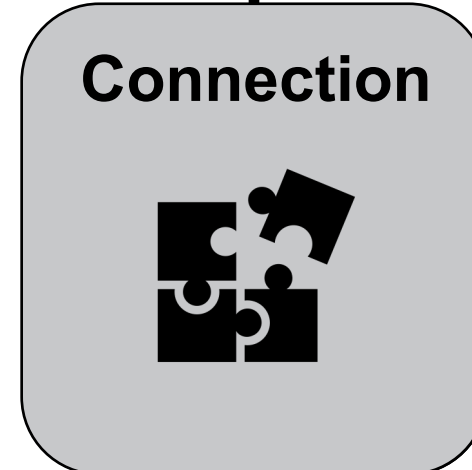
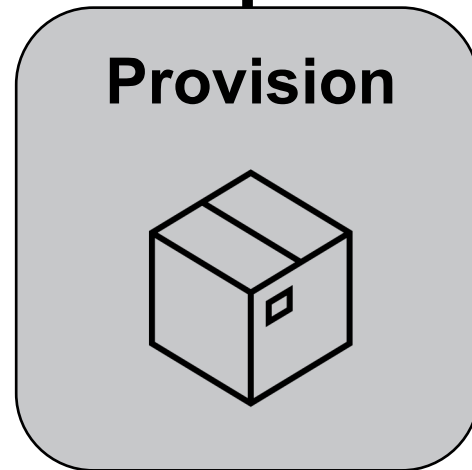
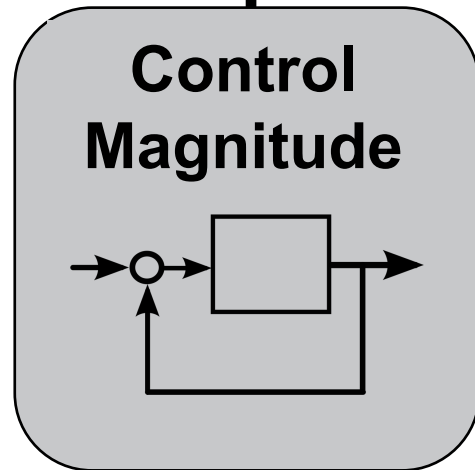
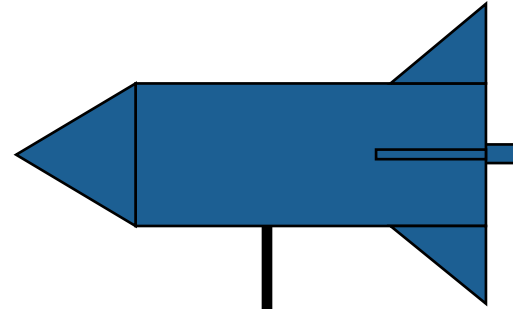

John Tietsworth

Metrics

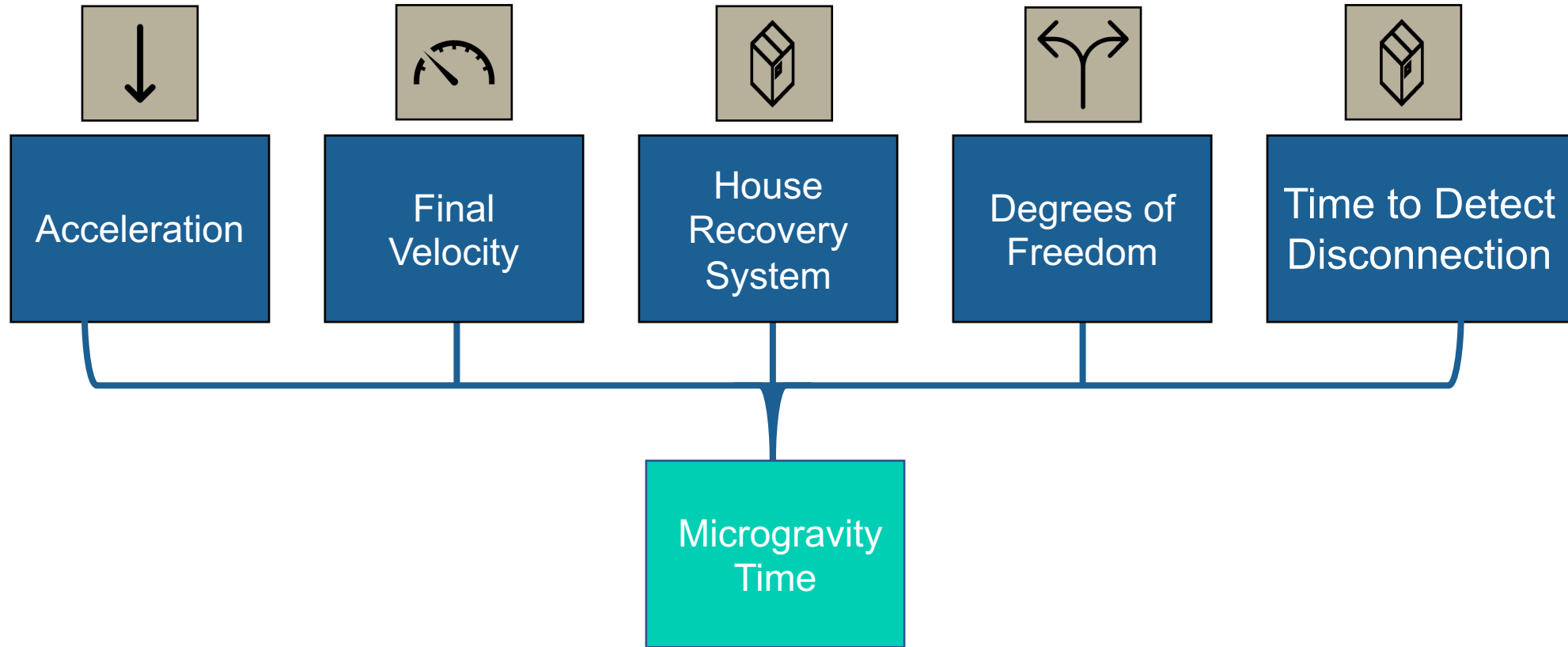

John Tietsworth

Targets and Metrics

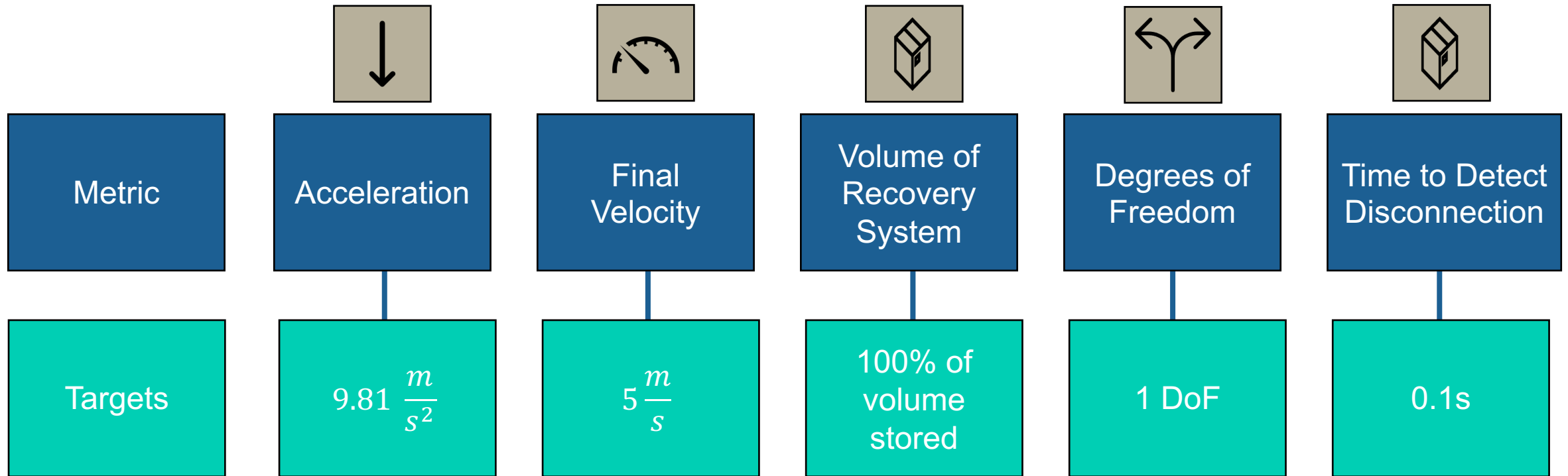

John Tietsworth

Concept Generation Tools

Biomimicry

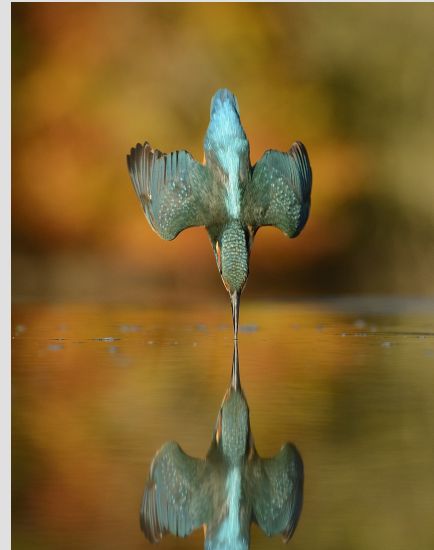

Morphological Chart

Propulsion	Recovery	Body	Stabilize
Expel propellant from nose of vehicle	Rear deployed parachute	Pointed front, blunt back	Fins
Expel propellant from sides of vehicle	Airbrakes	Football shape	Use water to spin the body
Electric motor propeller at the rear of the device	Airbag	Rubbery Skin	Use airbrakes to make it spin
Electric motor propeller at the front of the device	Side deployed parachute	Needle like, long and skinny	Thrust vectoring
No propulsion			

Collin Gainer

Concept Generation

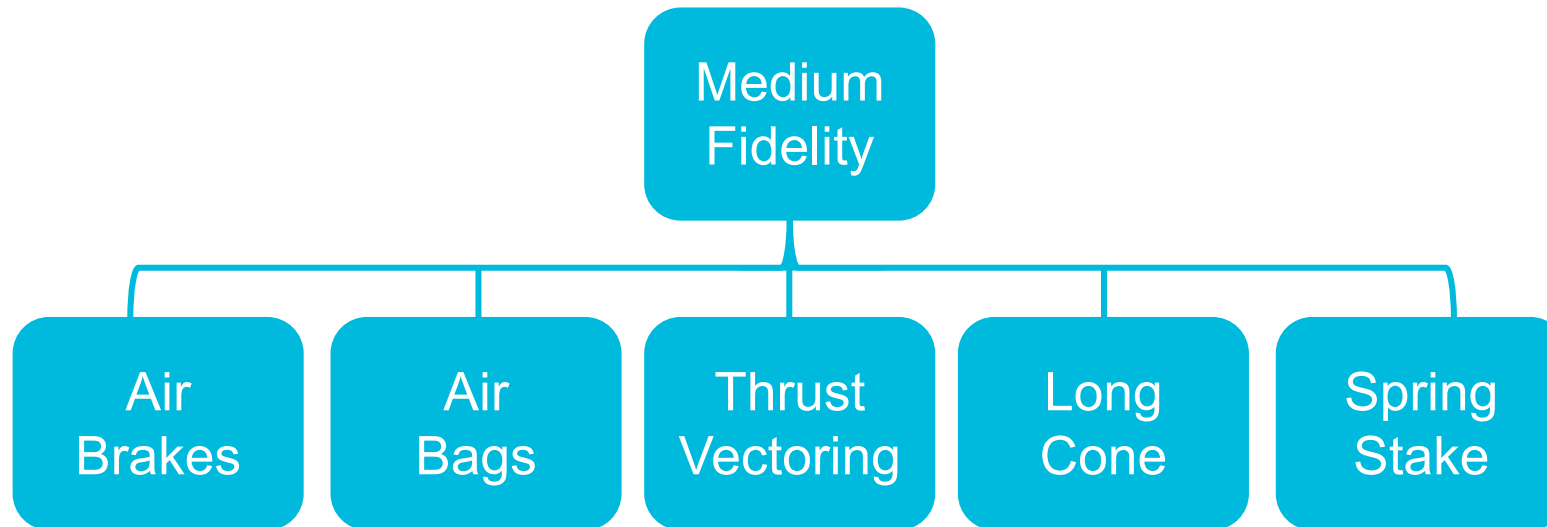

Collin Gainer

Concept Generation

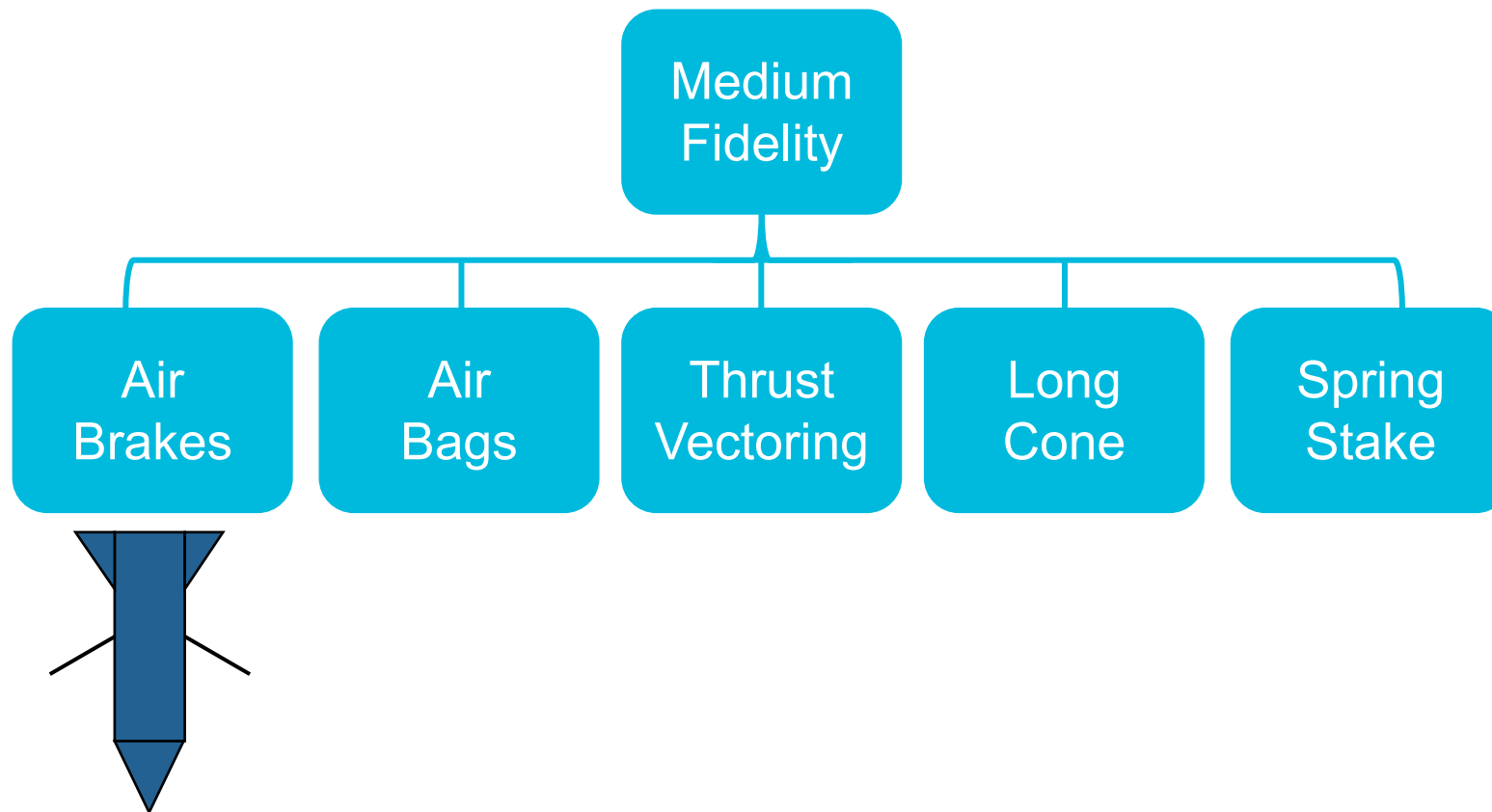

Collin Gainer

Concept Generation

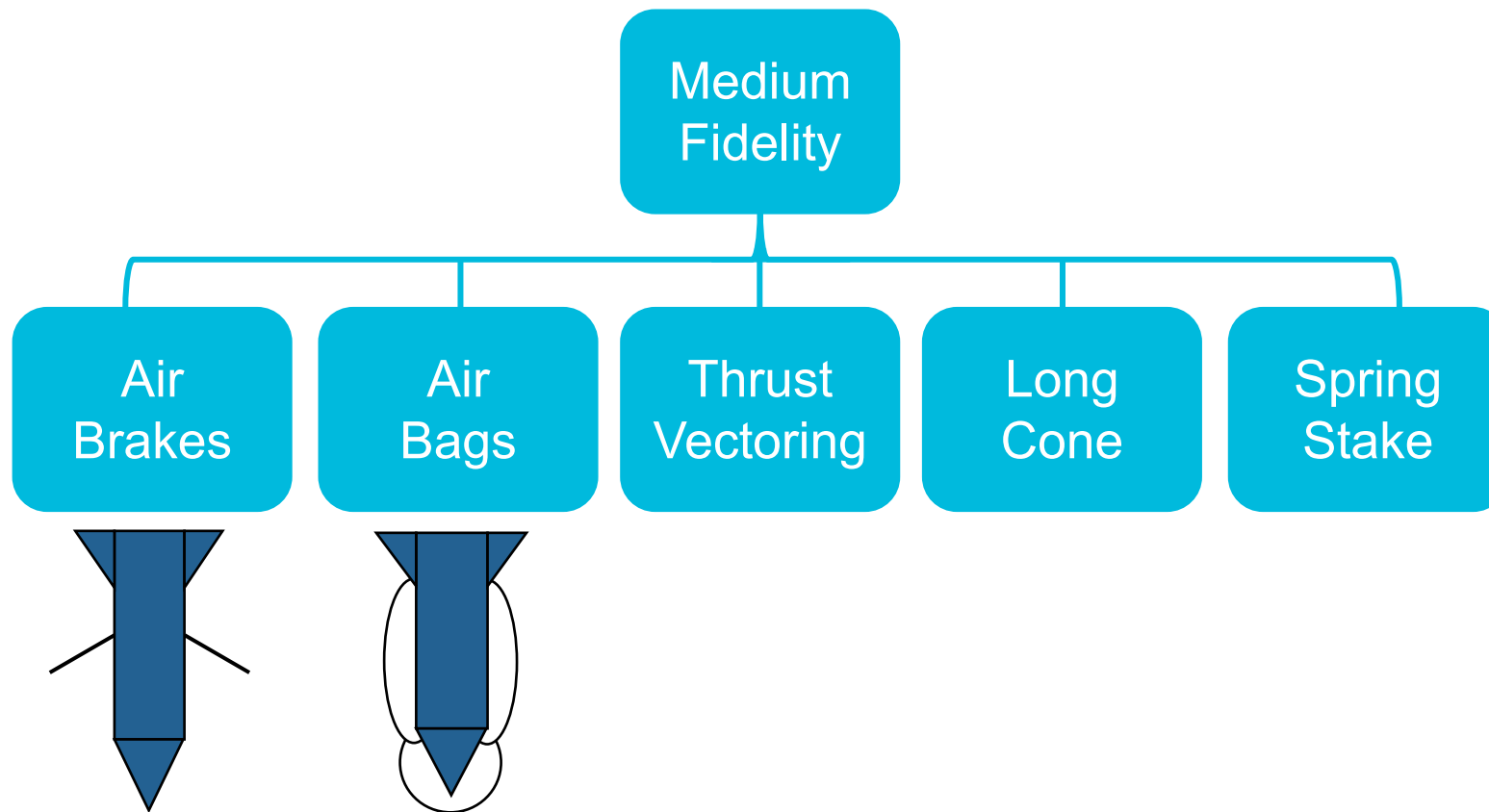

Collin Gainer

Concept Generation

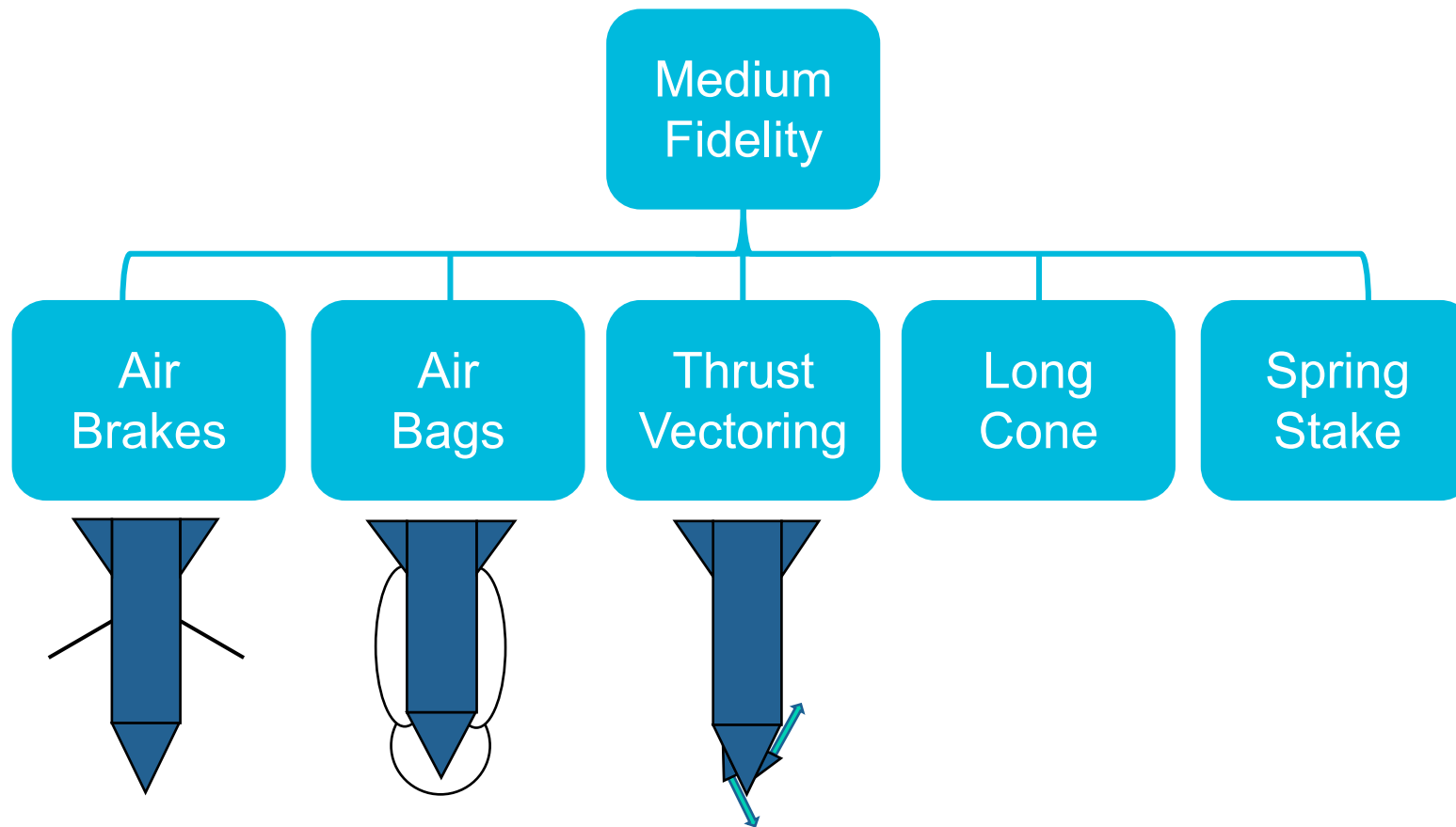

Collin Gainer

Concept Generation

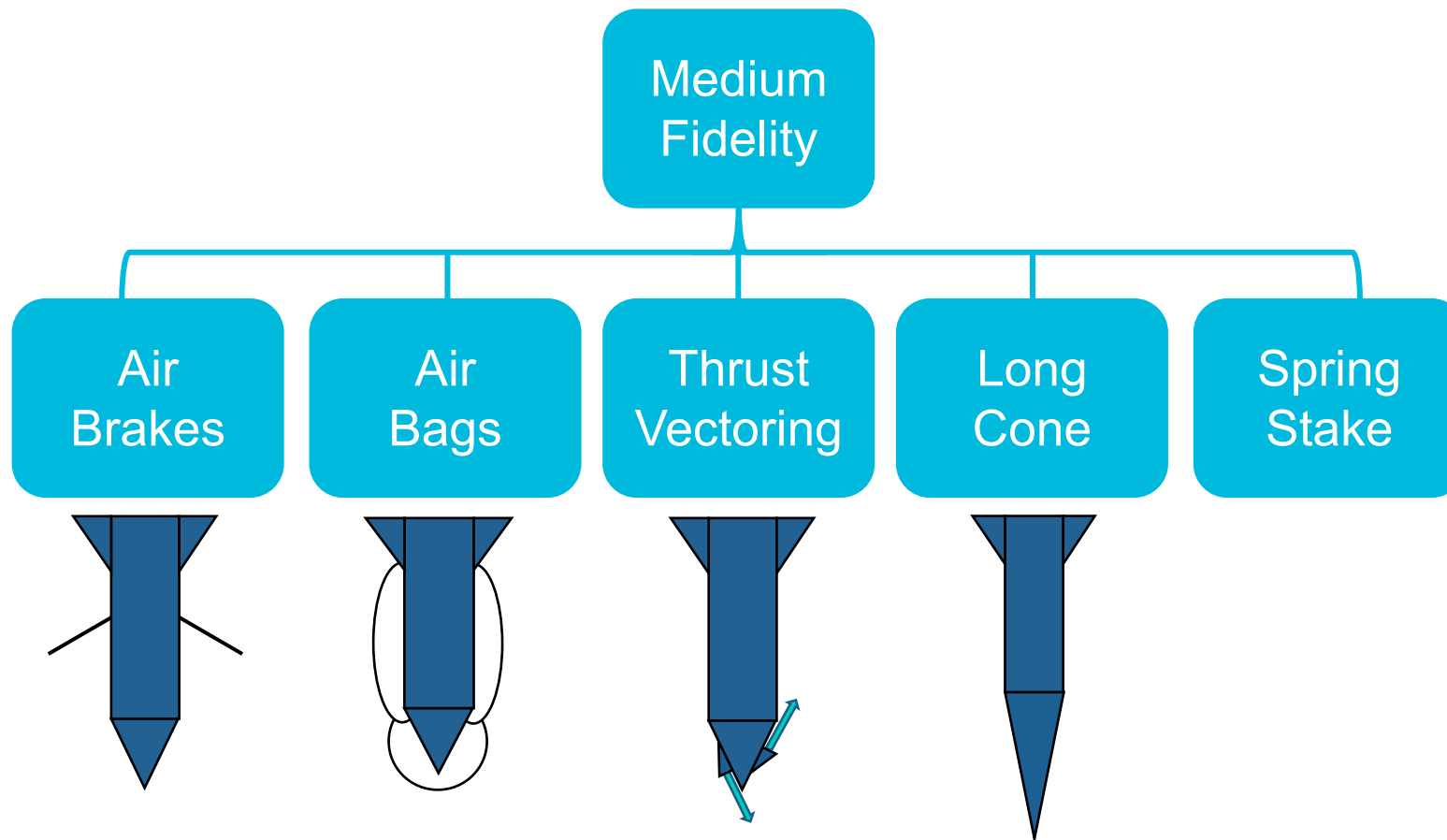

Collin Gainer

Concept Generation

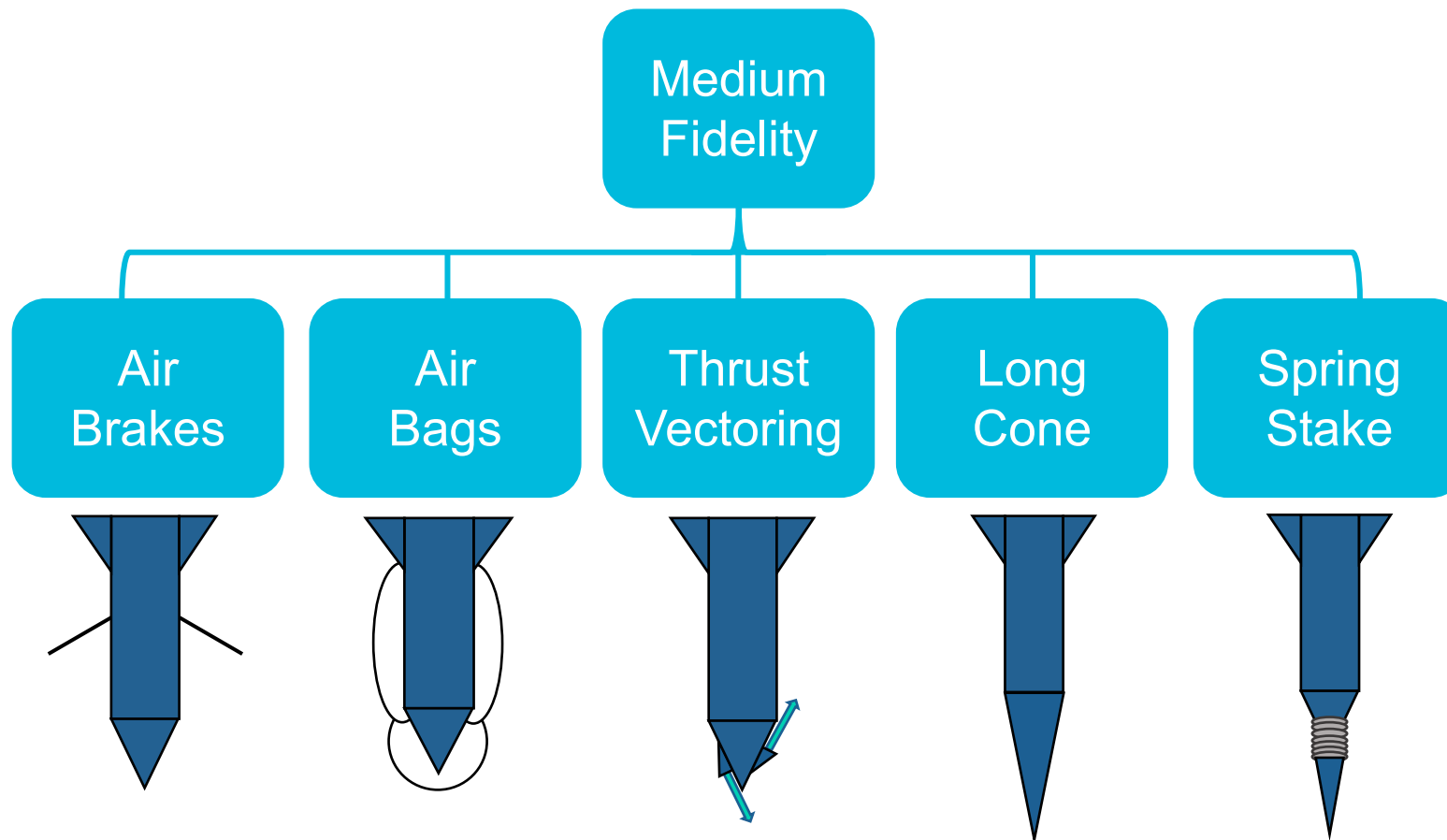

Collin Gainer

Concept Generation

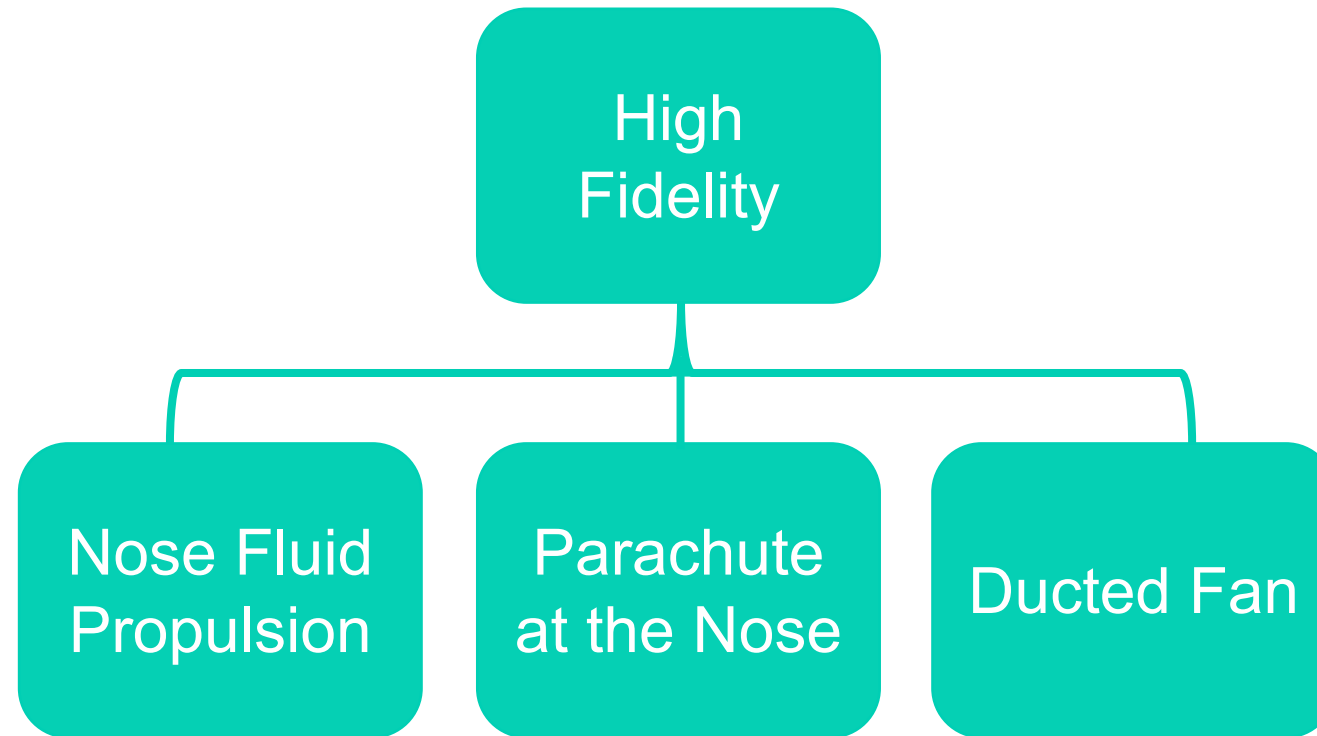

Collin Gainer

Design #1: Nose Fluid Propulsion

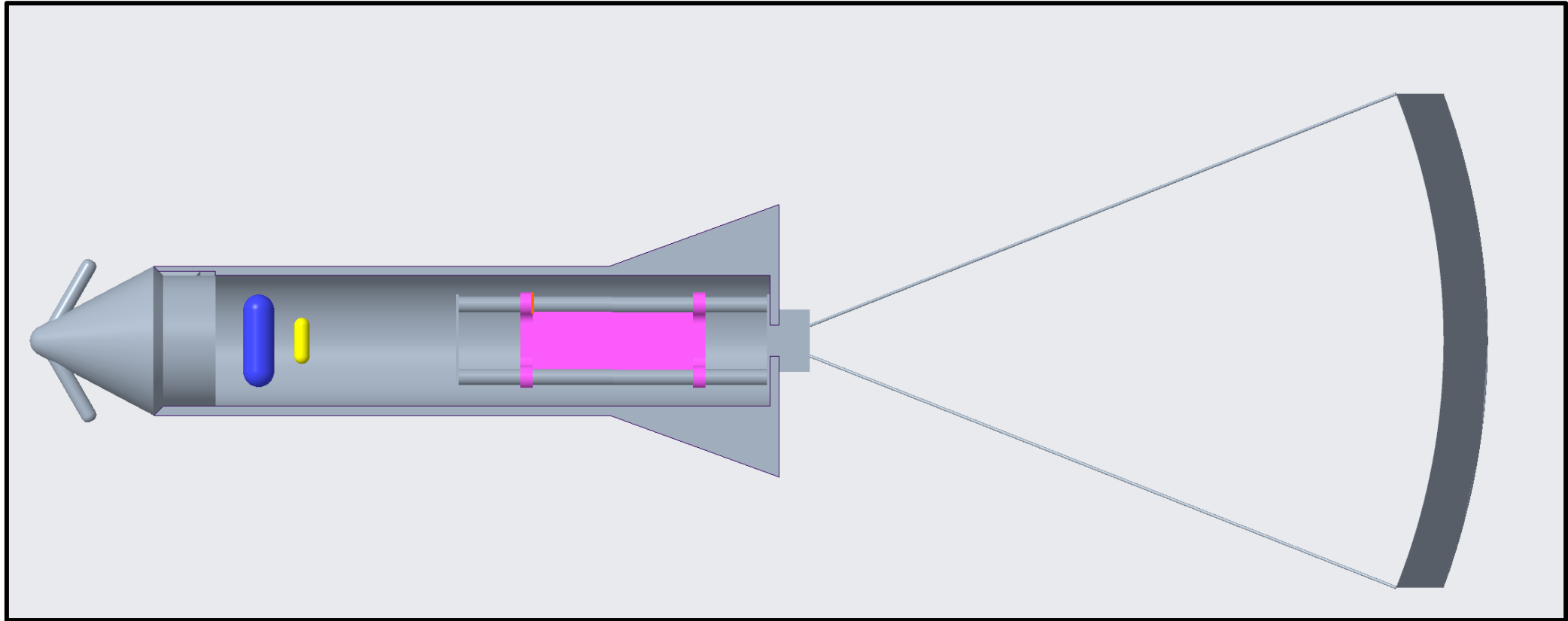

Collin Gainer

Design #1: Nose Fluid Propulsion

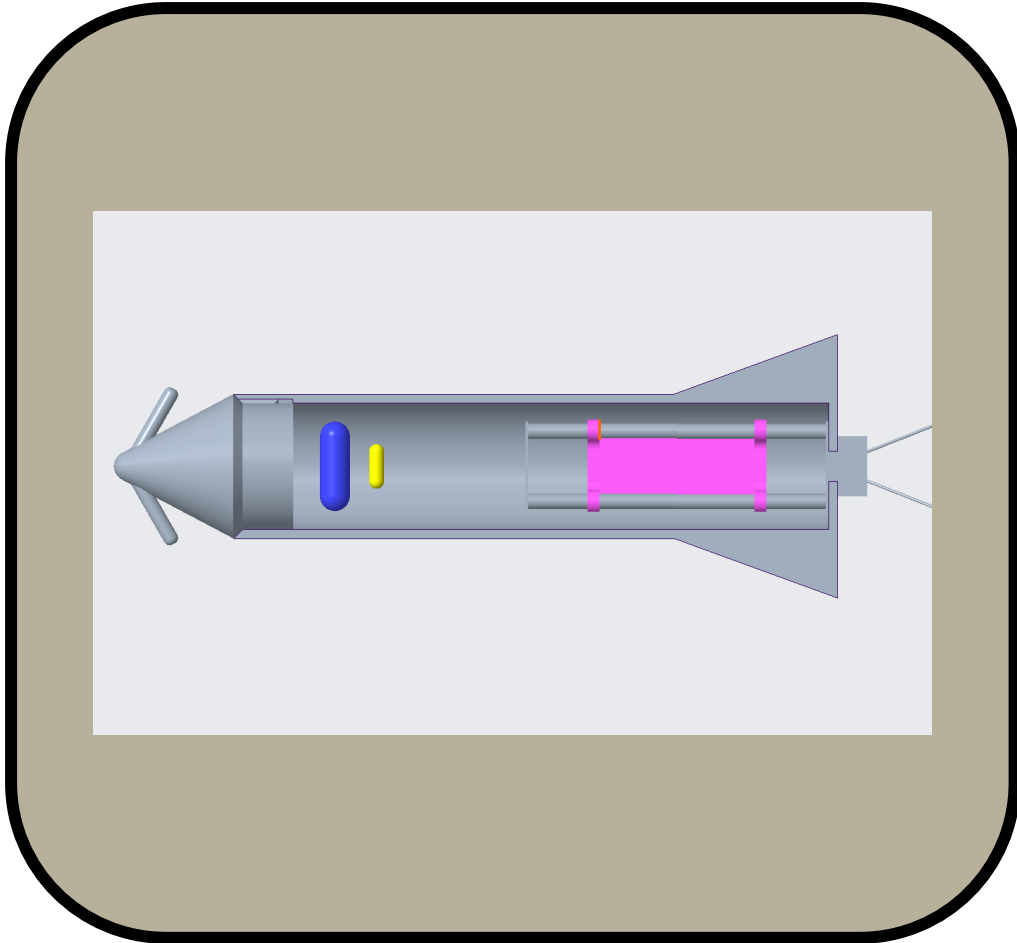

1

2

3

4

Collin Gainer

Design #1: Nose Fluid Propulsion

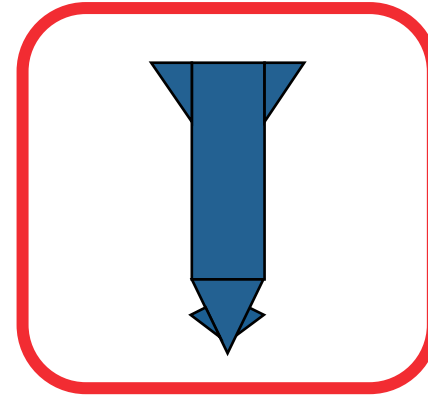
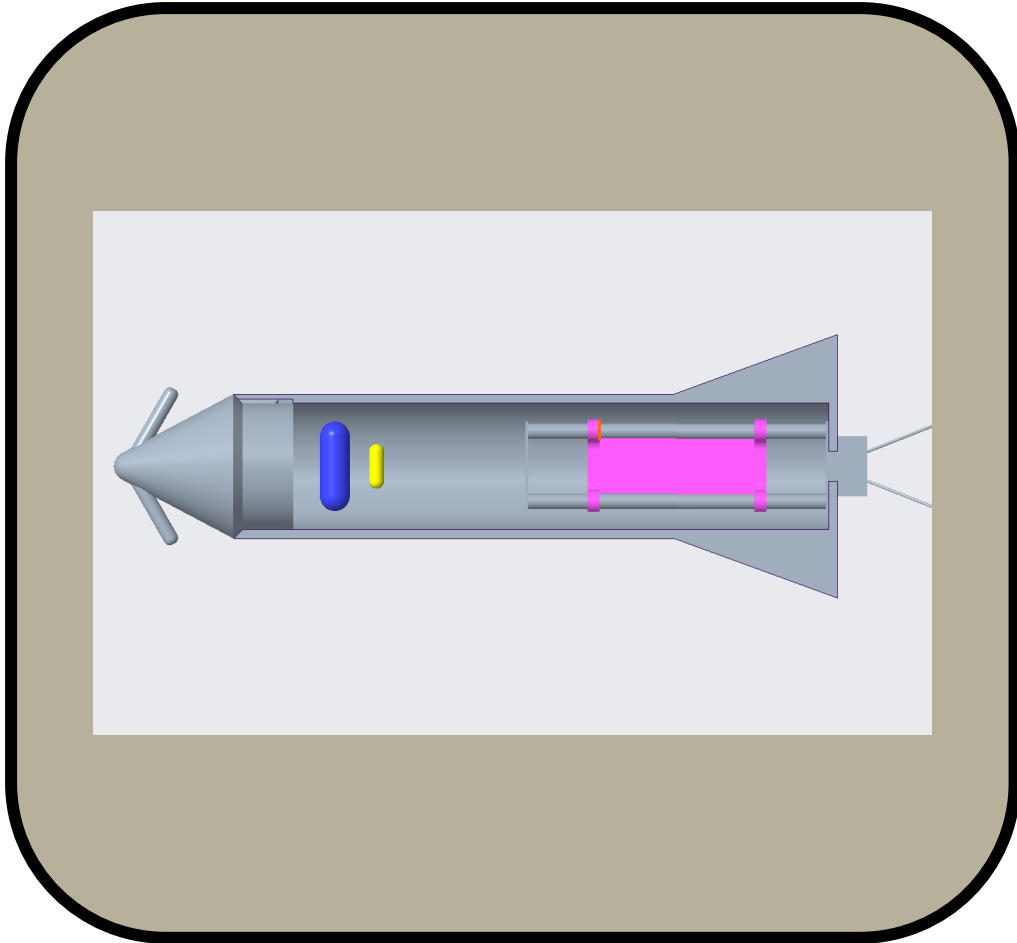

Collin Gainer

Design #1: Nose Fluid Propulsion

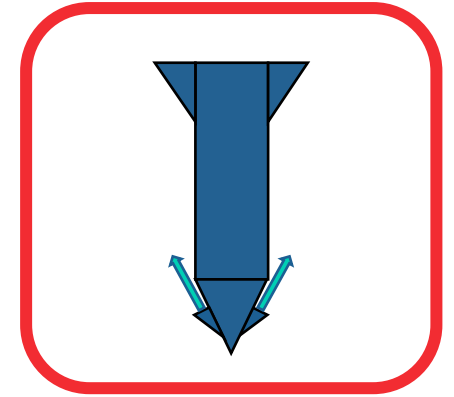
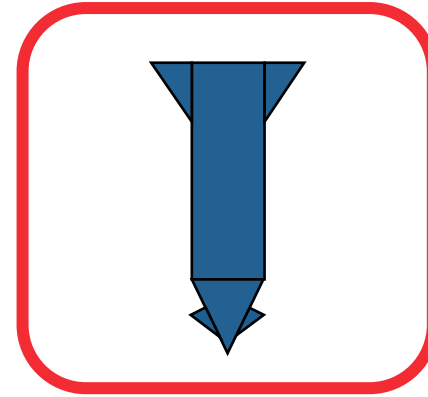
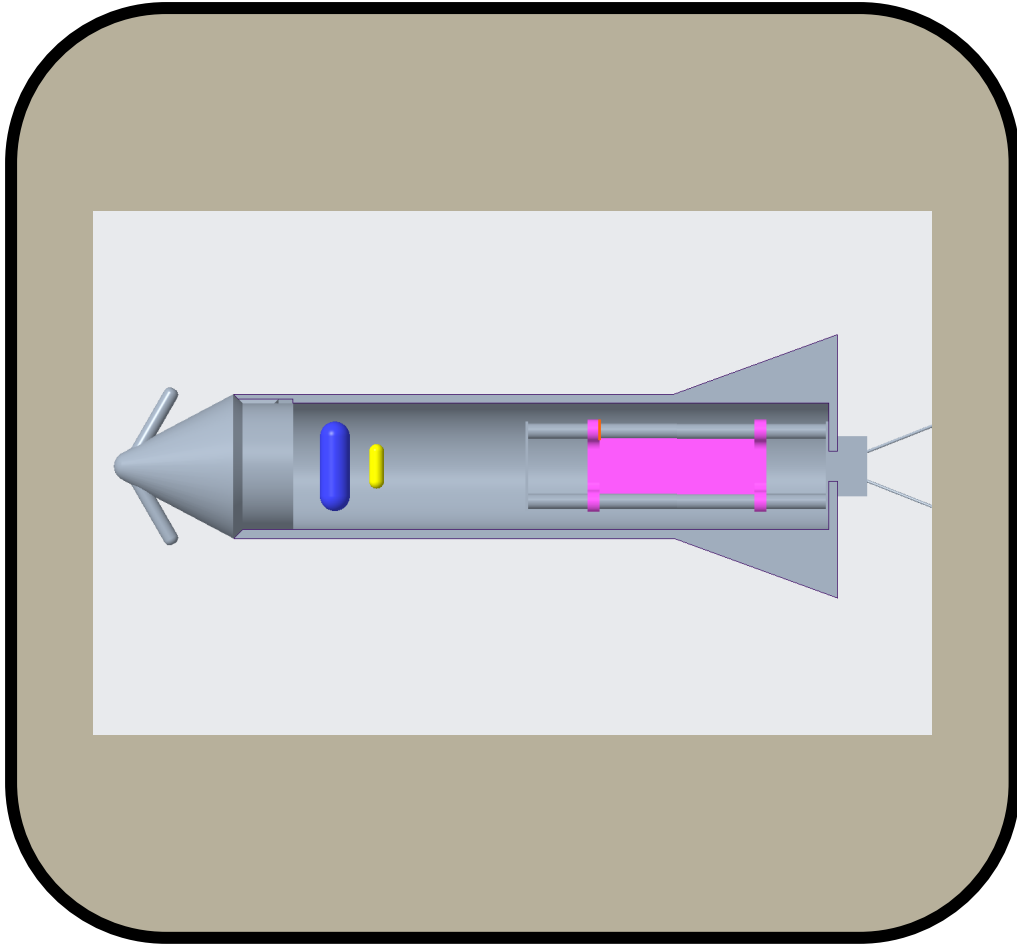

Collin Gainer

Design #1: Nose Fluid Propulsion

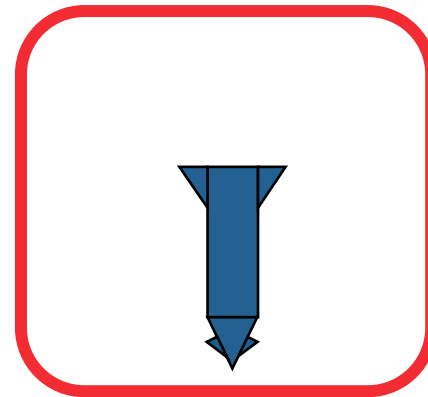
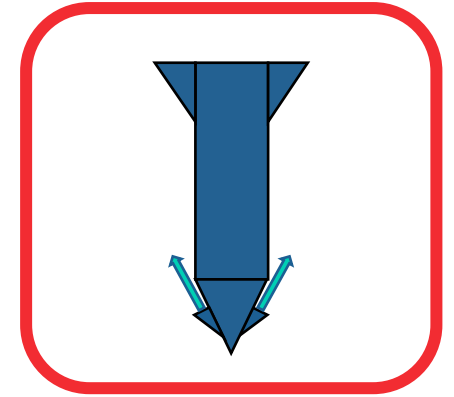
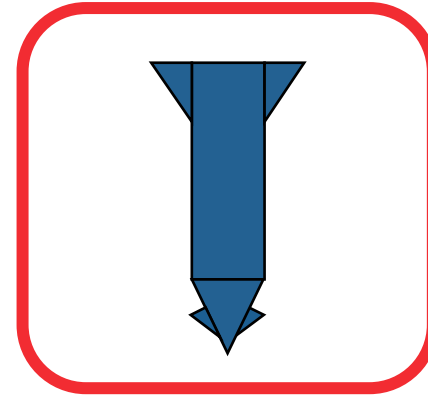
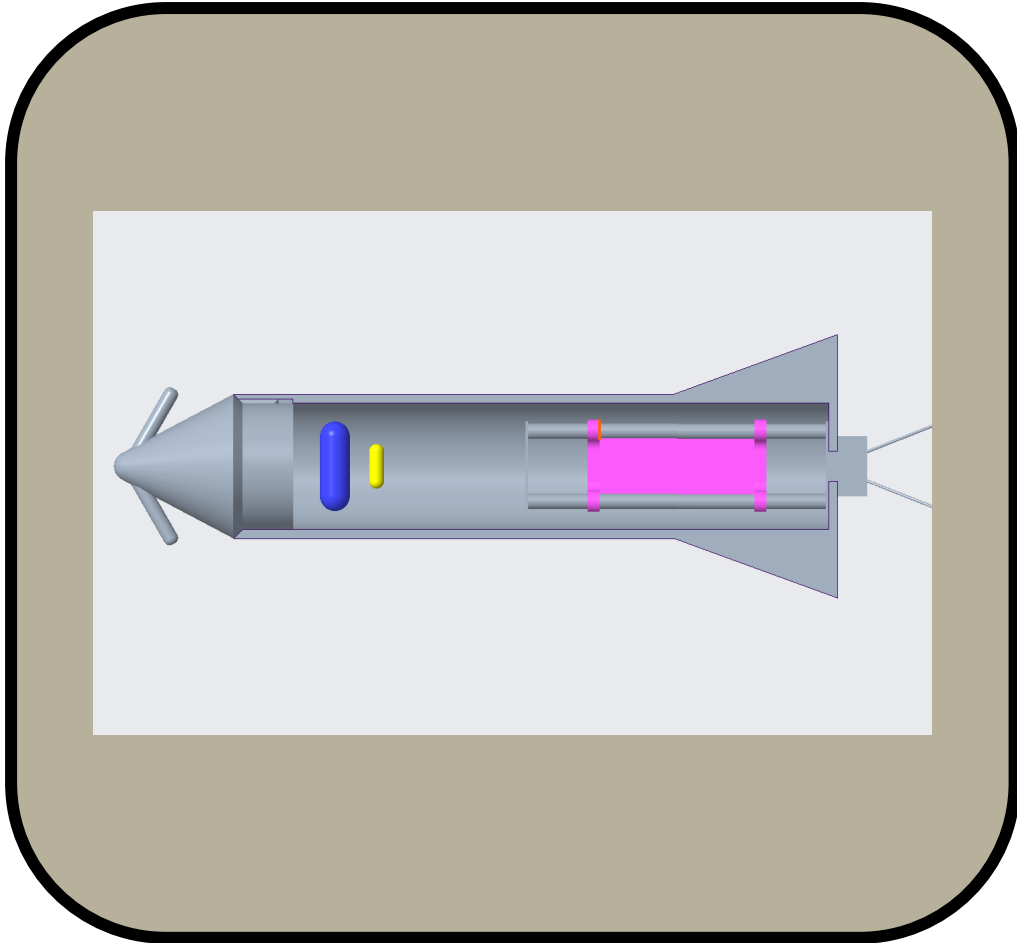

Collin Gainer

Design #1: Nose Fluid Propulsion

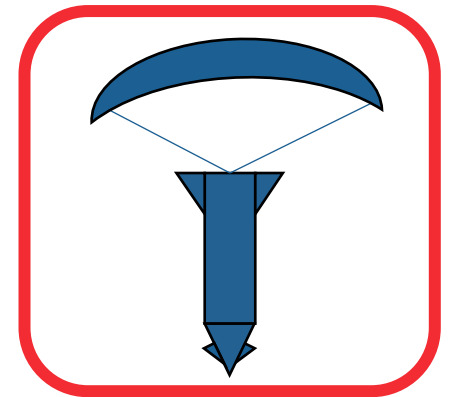
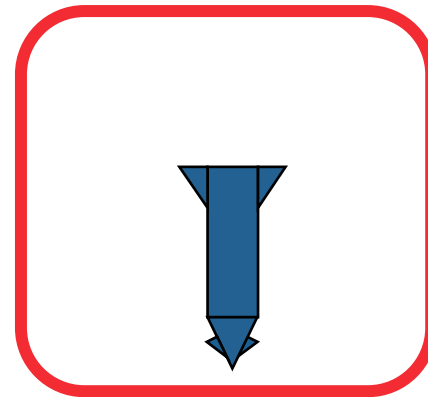
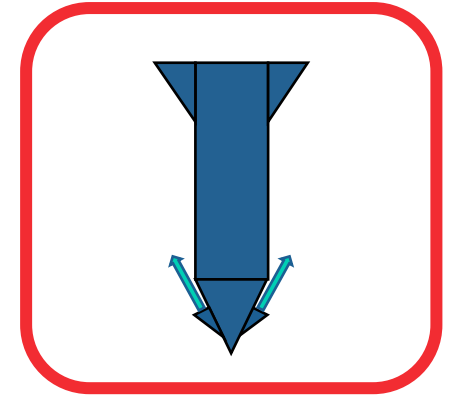
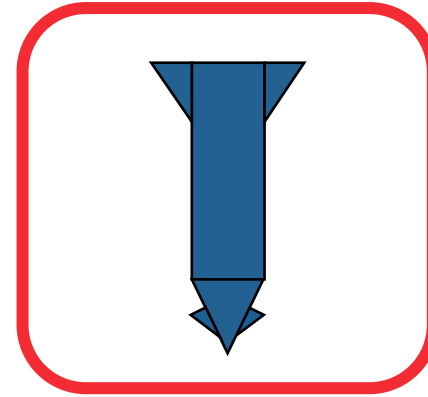
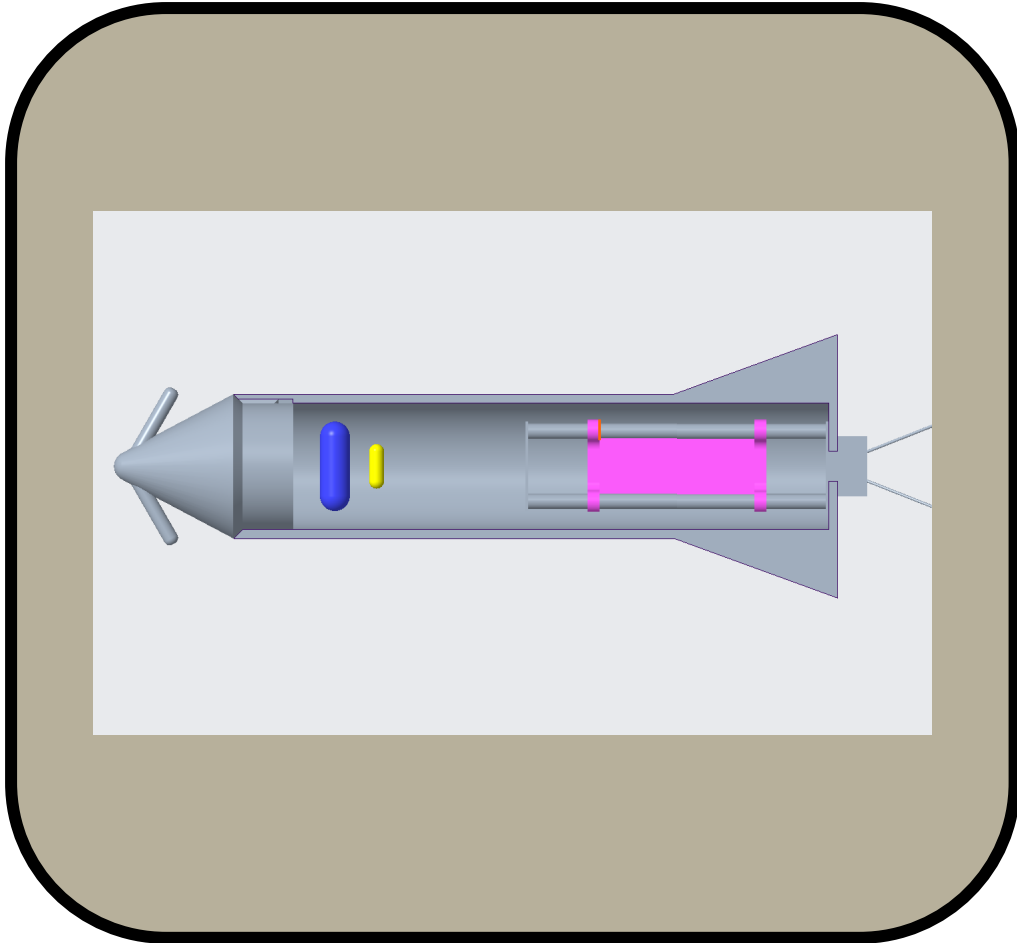

Collin Gainer

Design #2: Parachute at Nose

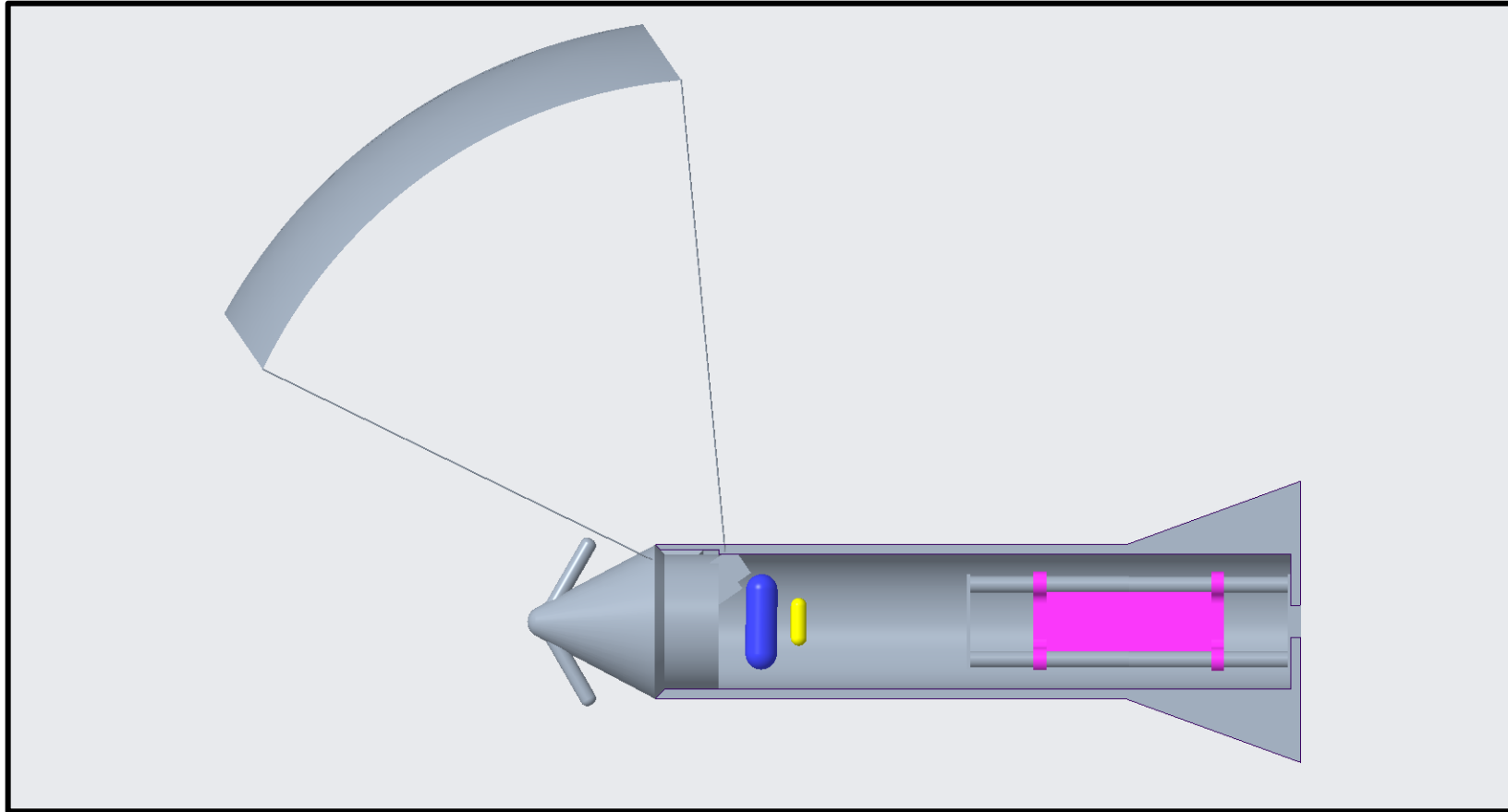

Collin Gainer

Design #2: Parachute at Nose

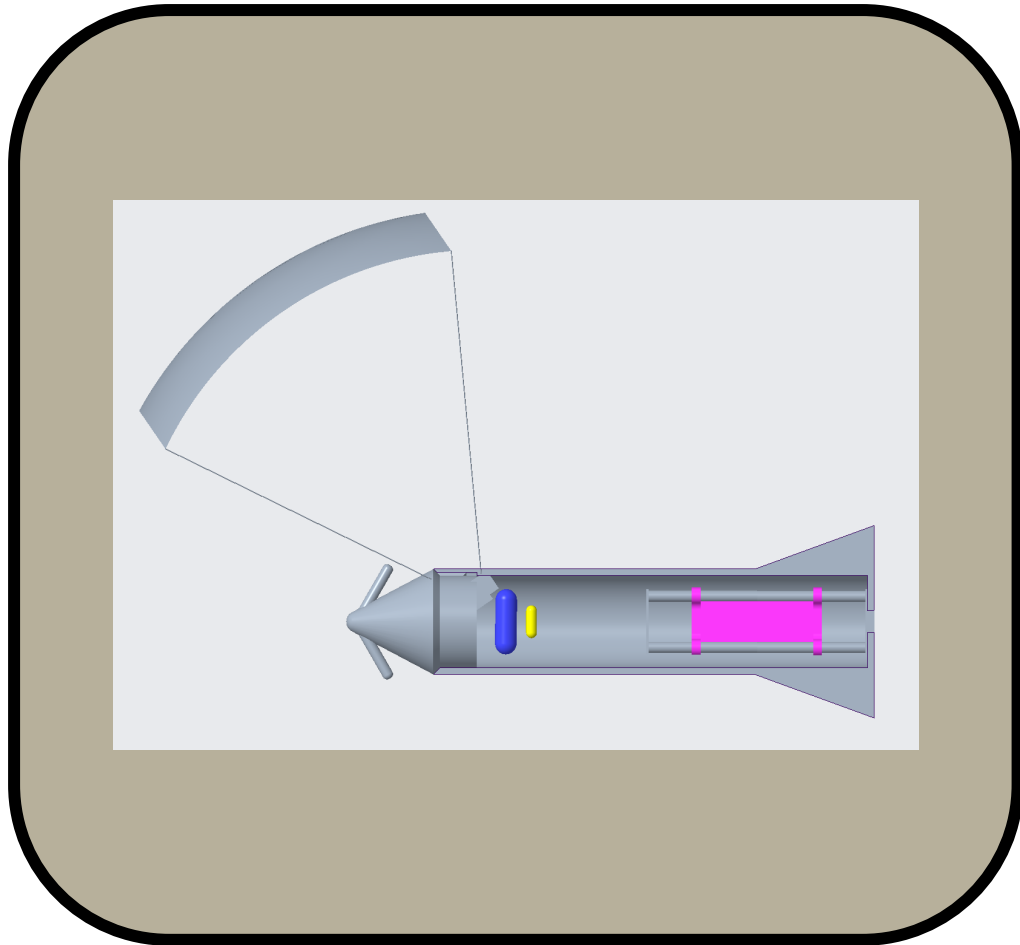

Collin Gainer

Design #2: Parachute at Nose

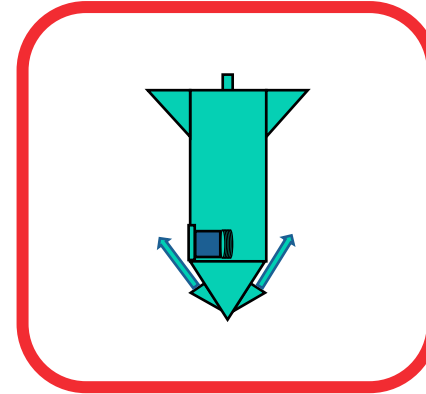
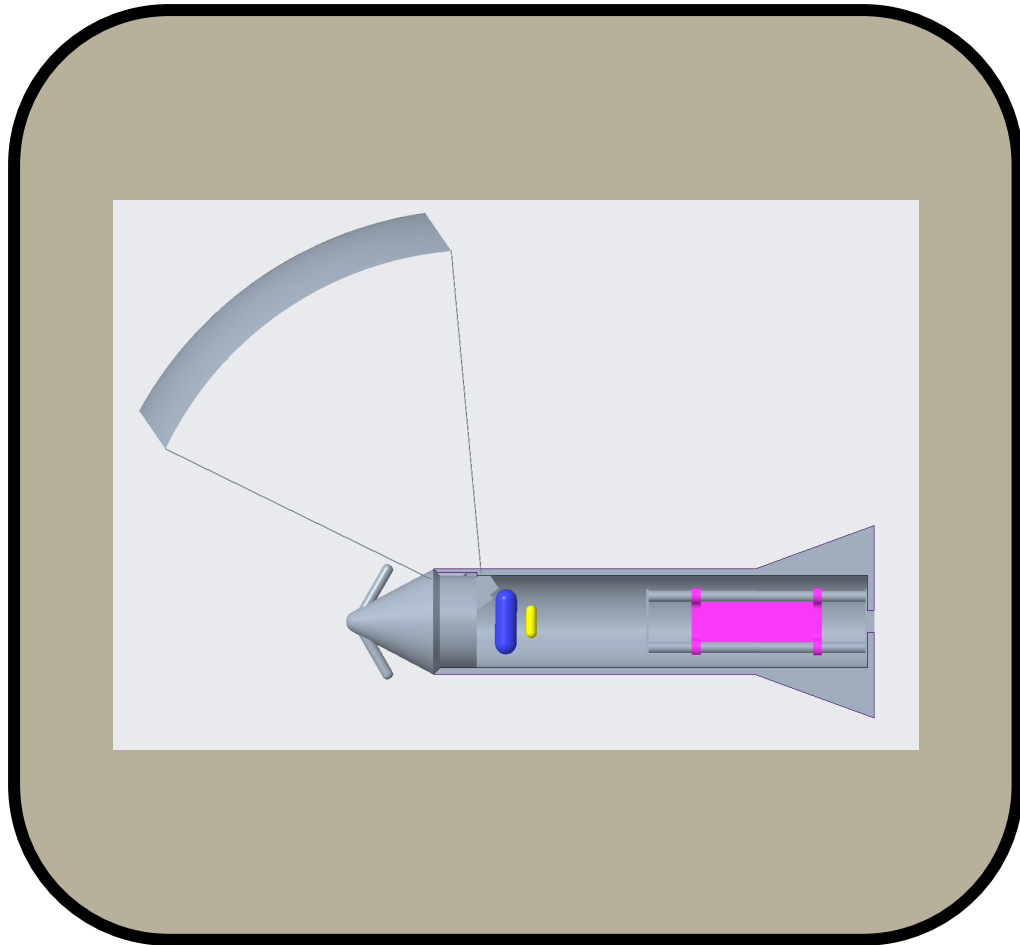

Collin Gainer

Design #2: Parachute at Nose

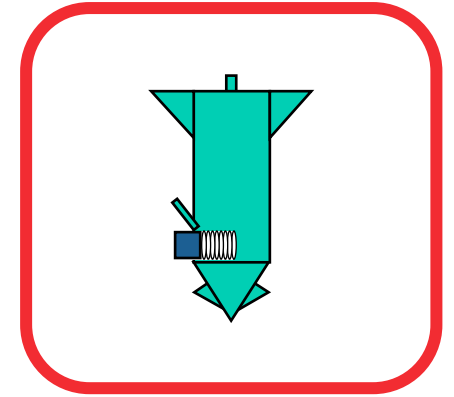
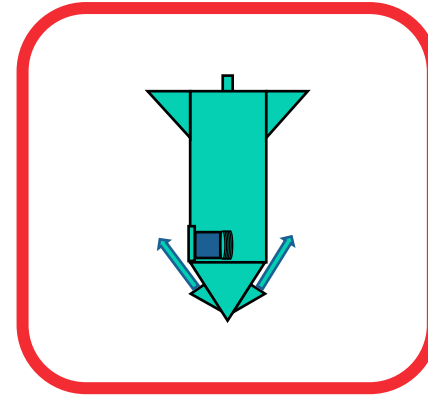
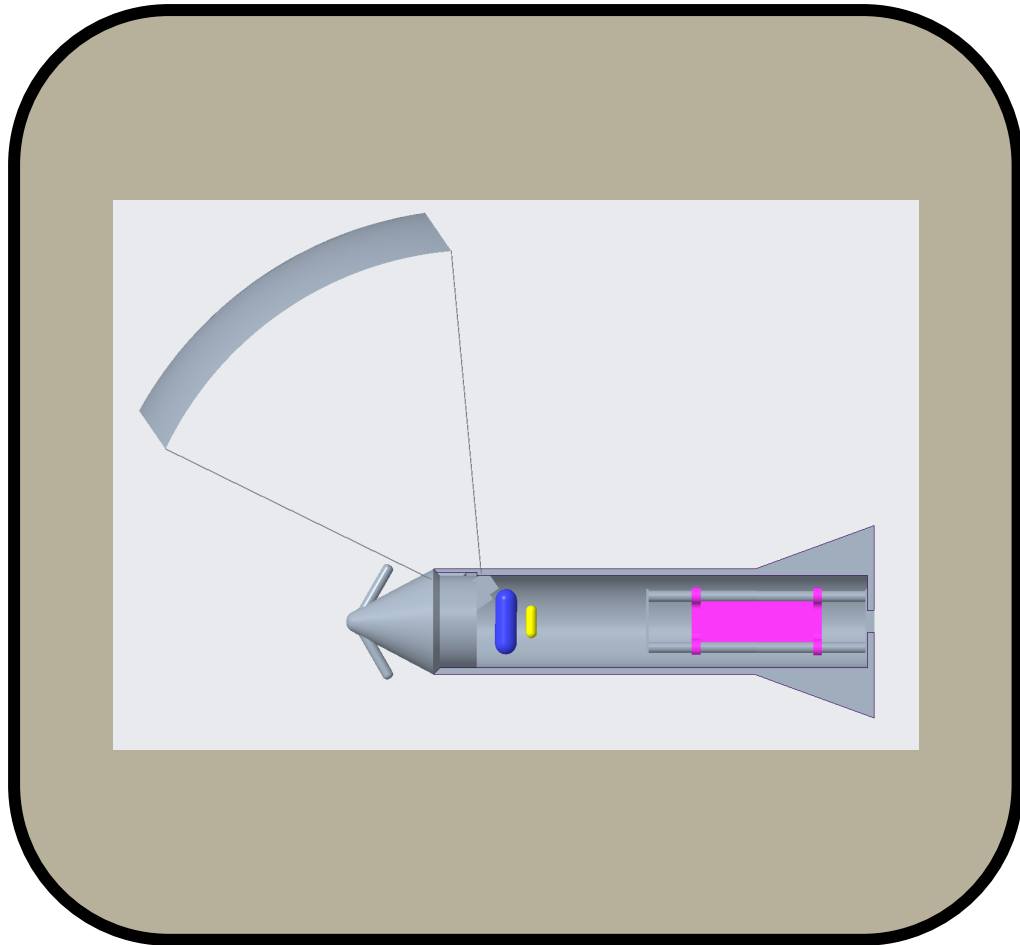

Collin Gainer

Design #2: Parachute at Nose

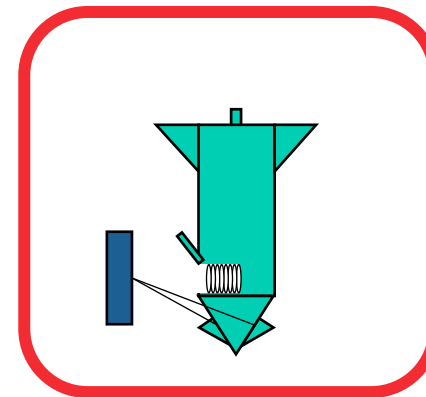
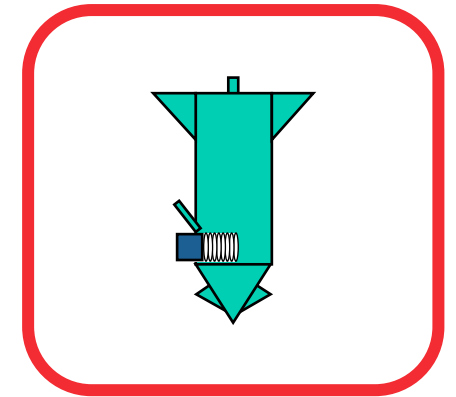
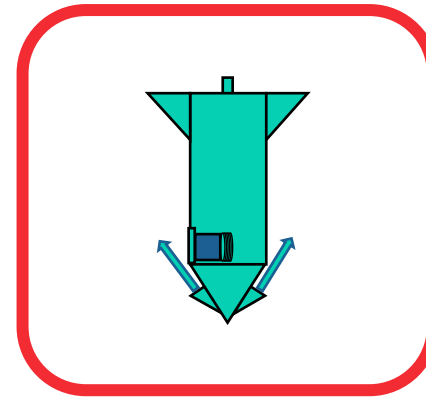
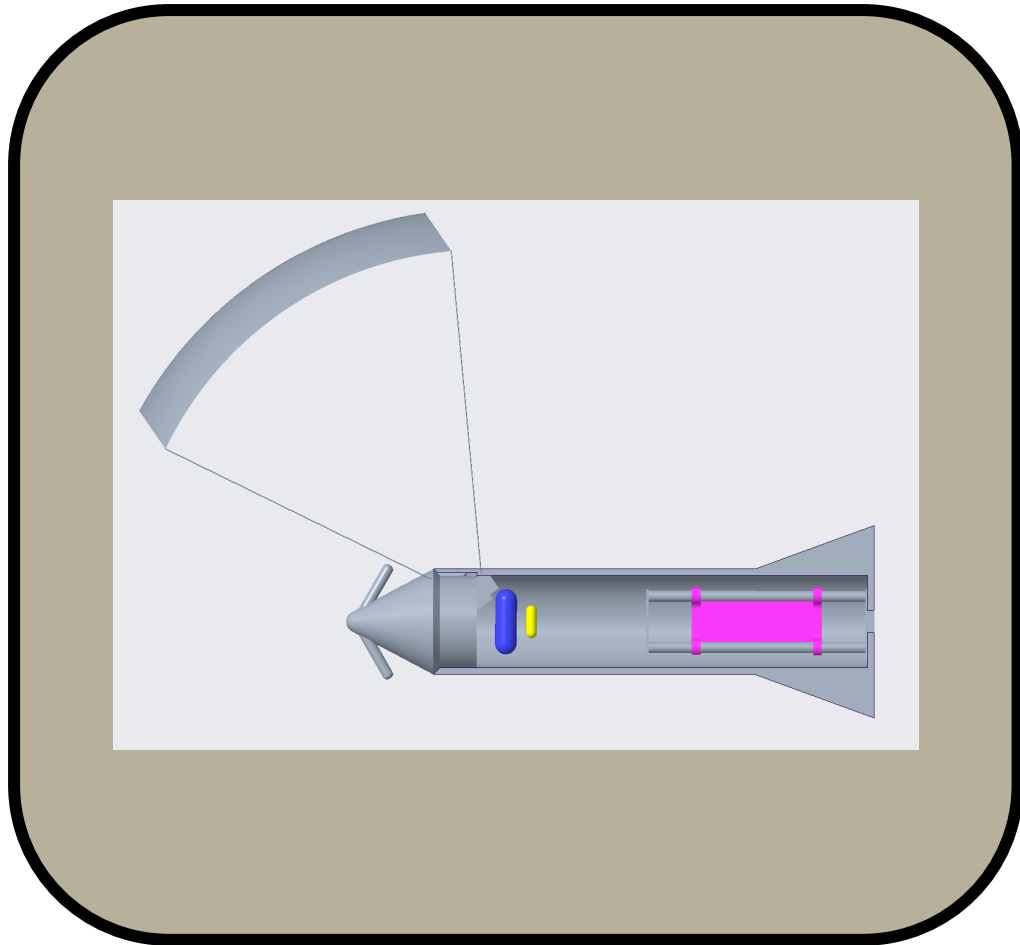

Collin Gainer

Design #2: Parachute at Nose

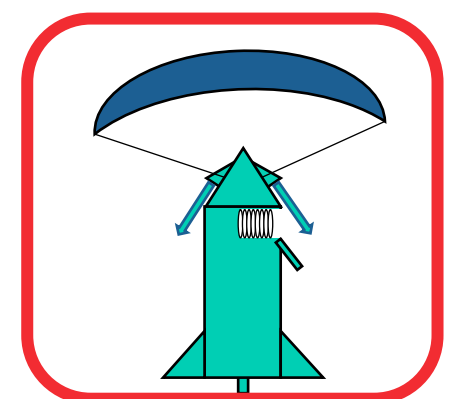
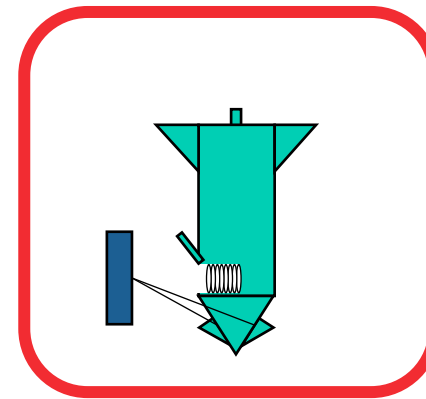
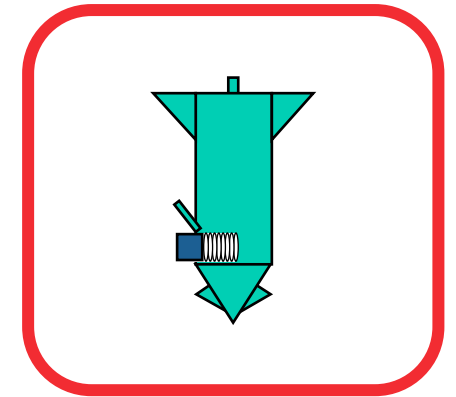
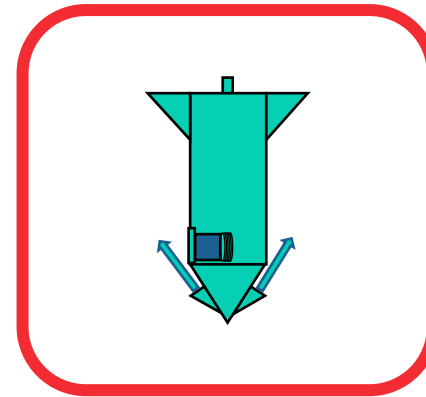
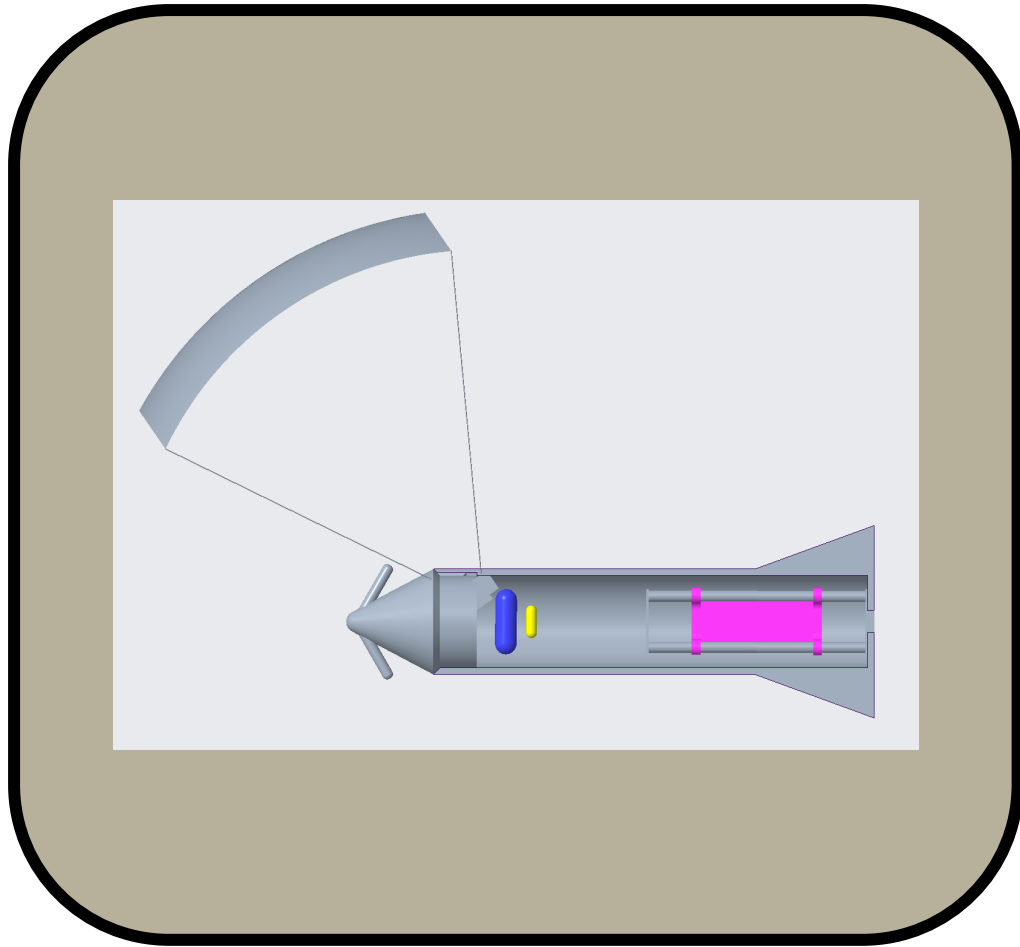

Collin Gainer

Design #3: Ducted Fan



Thomas Lenz

Selected Design: Ducted Fan

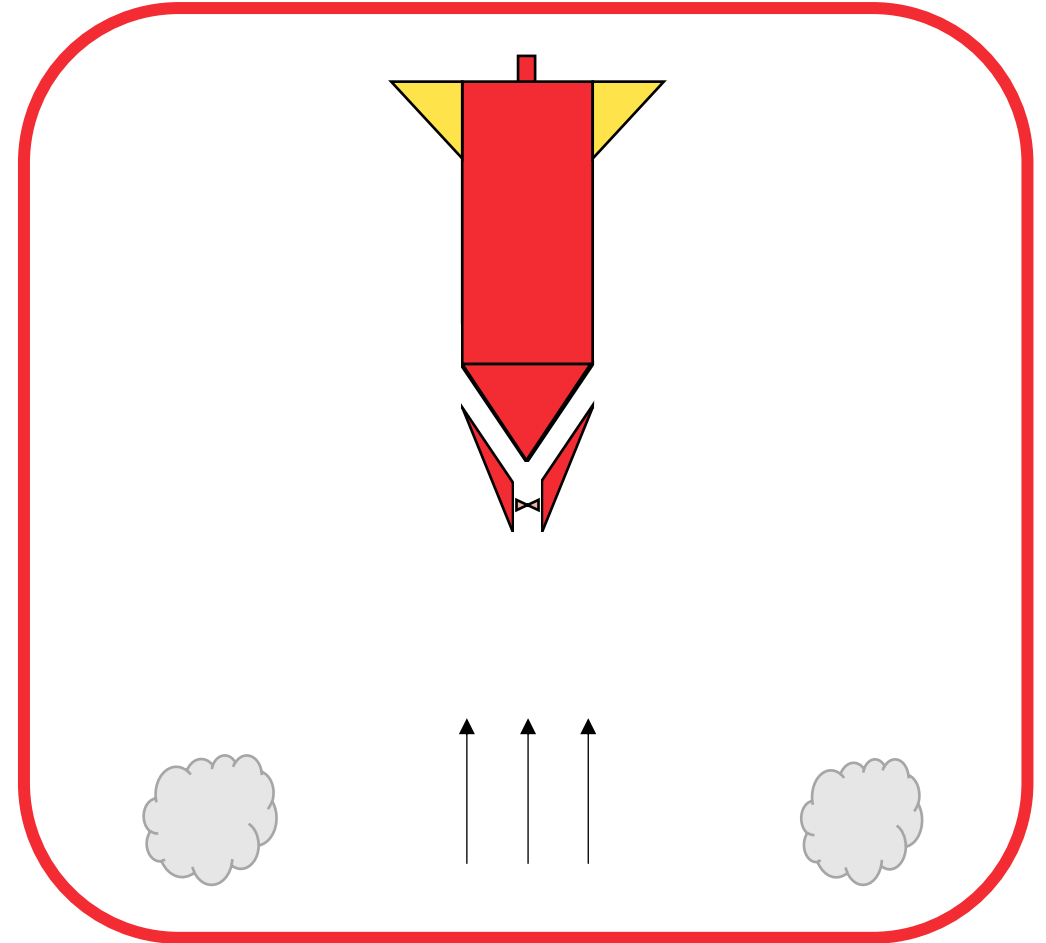
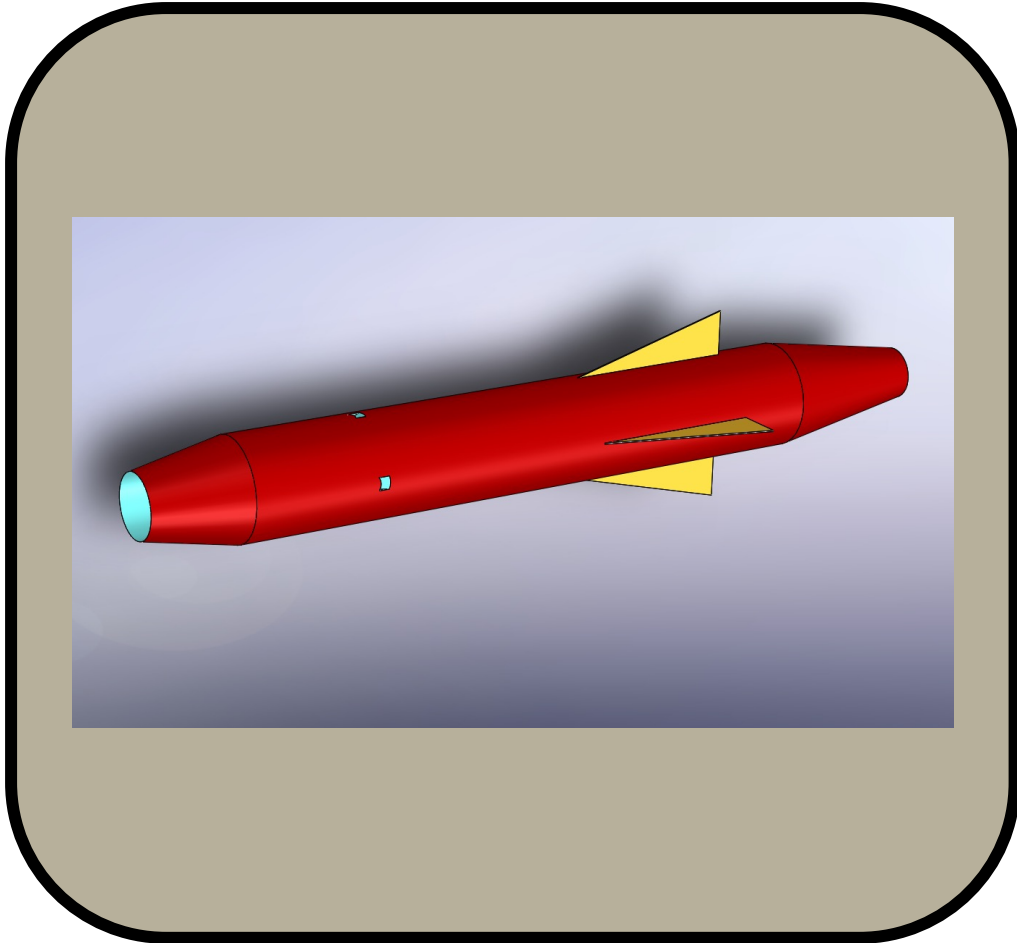

Thomas Lenz

Selected Design: Ducted Fan

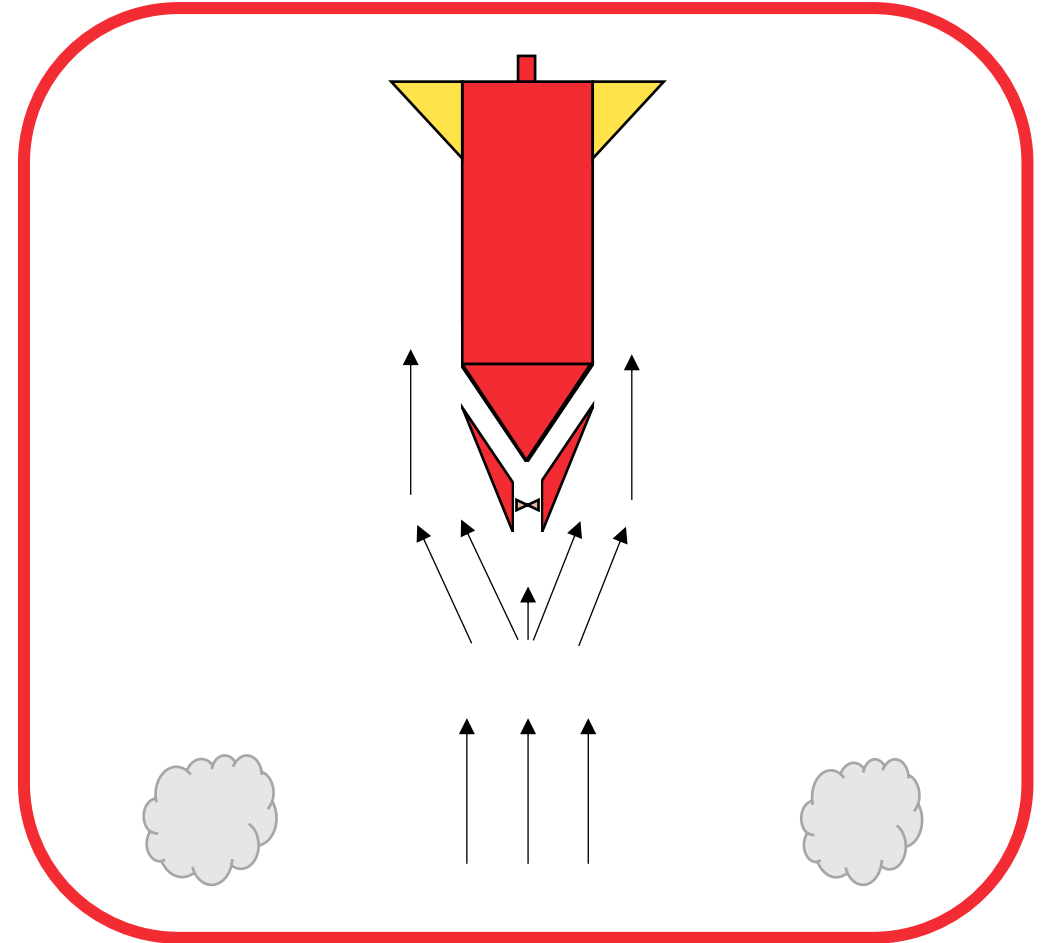
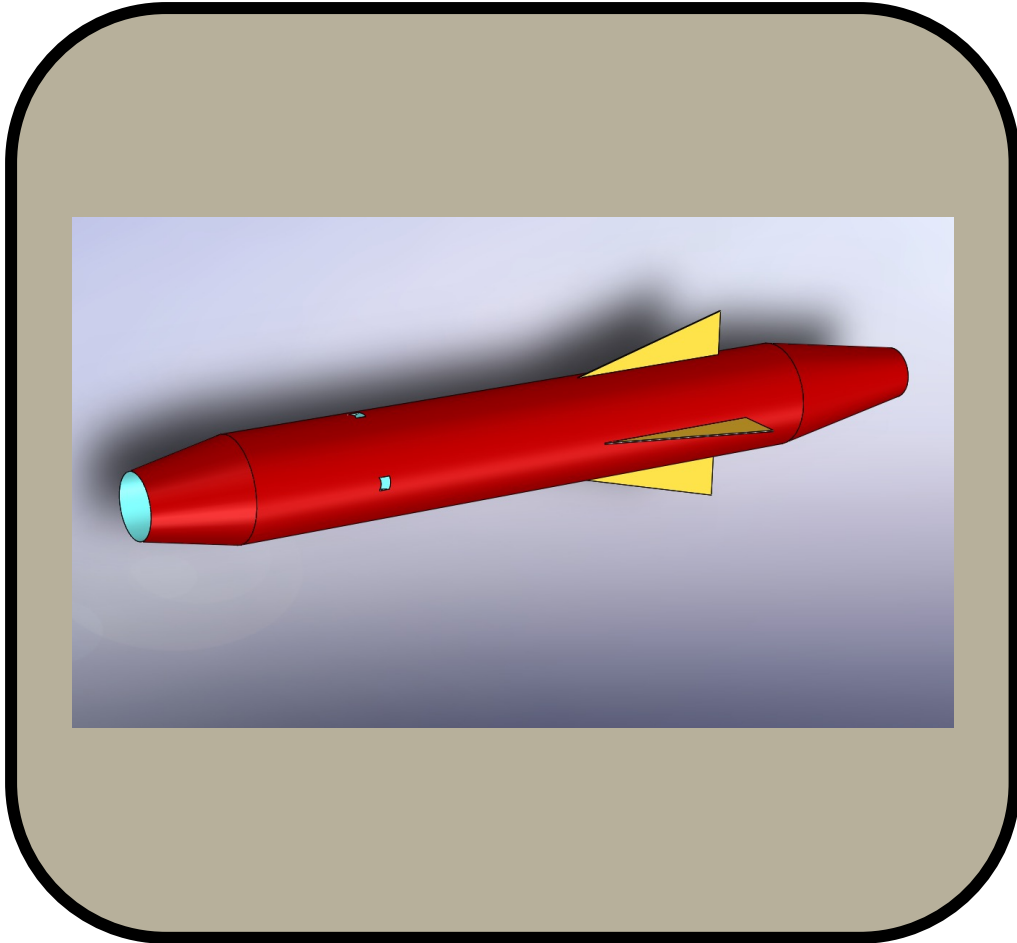

Thomas Lenz

Selected Design: Ducted Fan

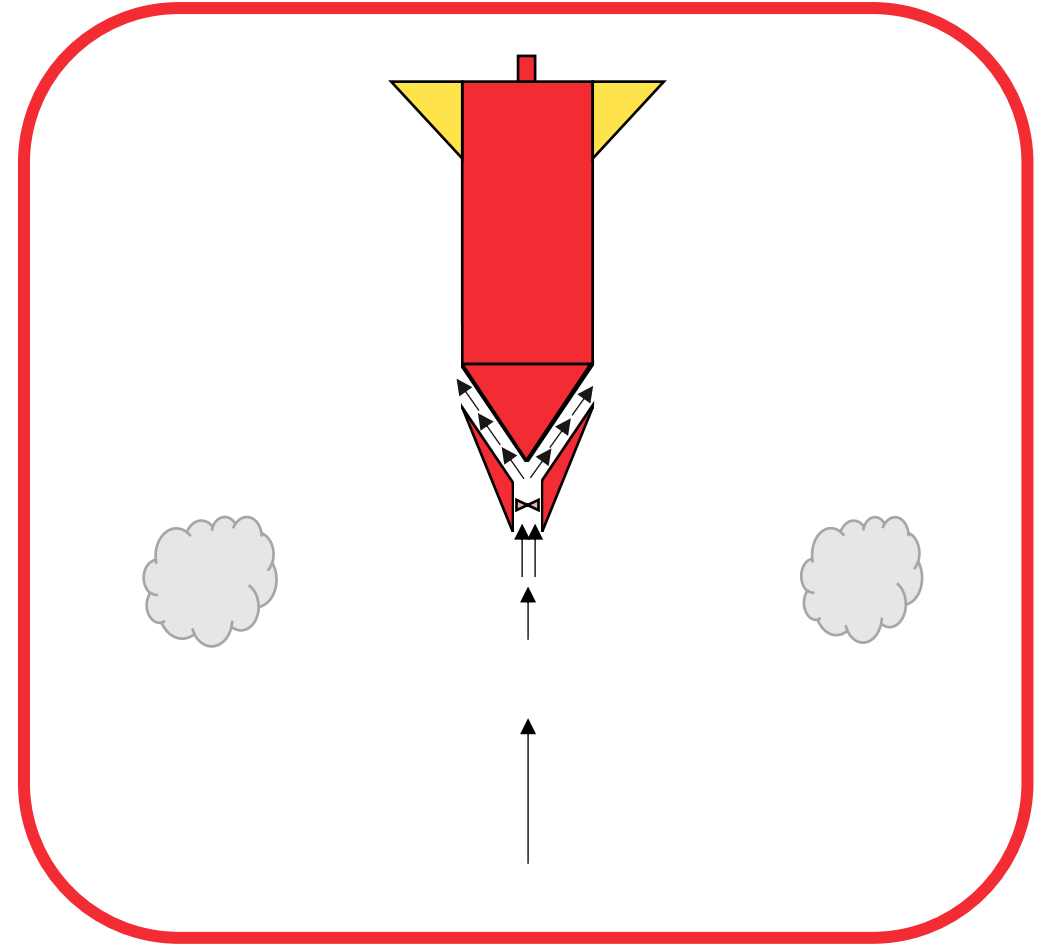
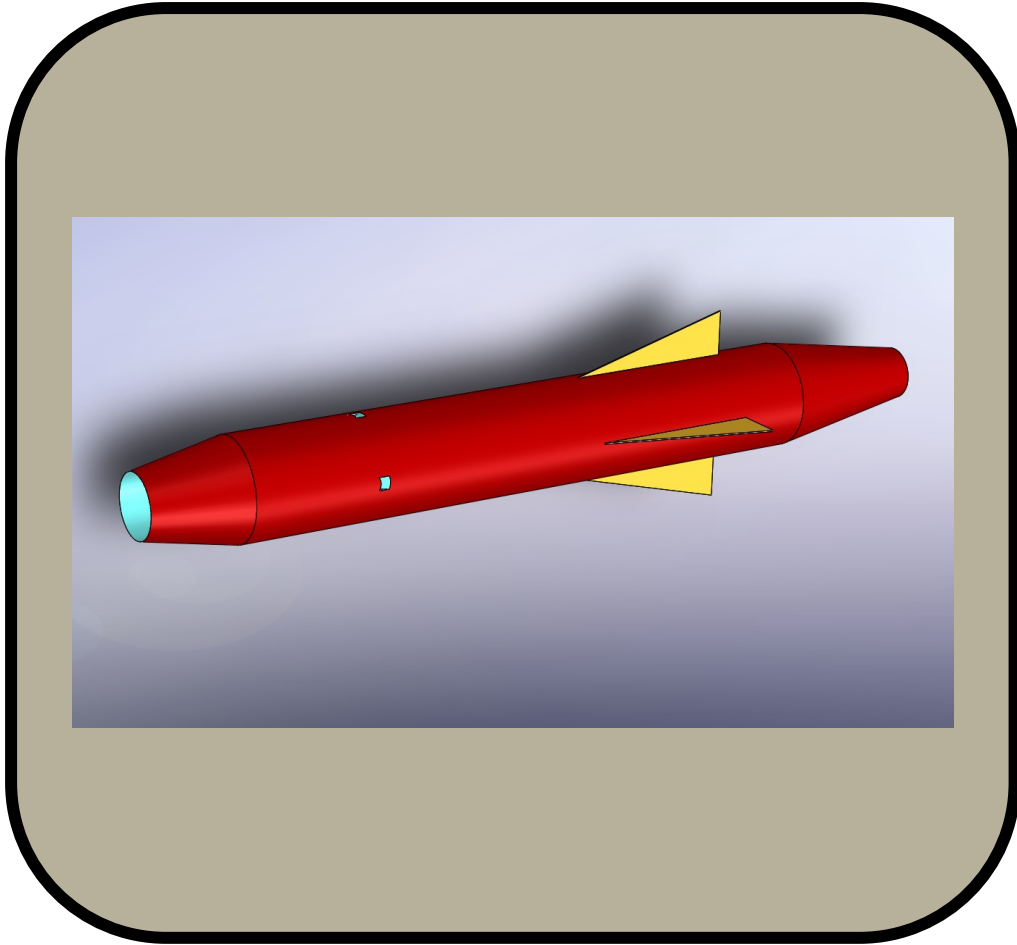

Thomas Lenz

Selected Design: Ducted Fan

Combats drag effects in two ways

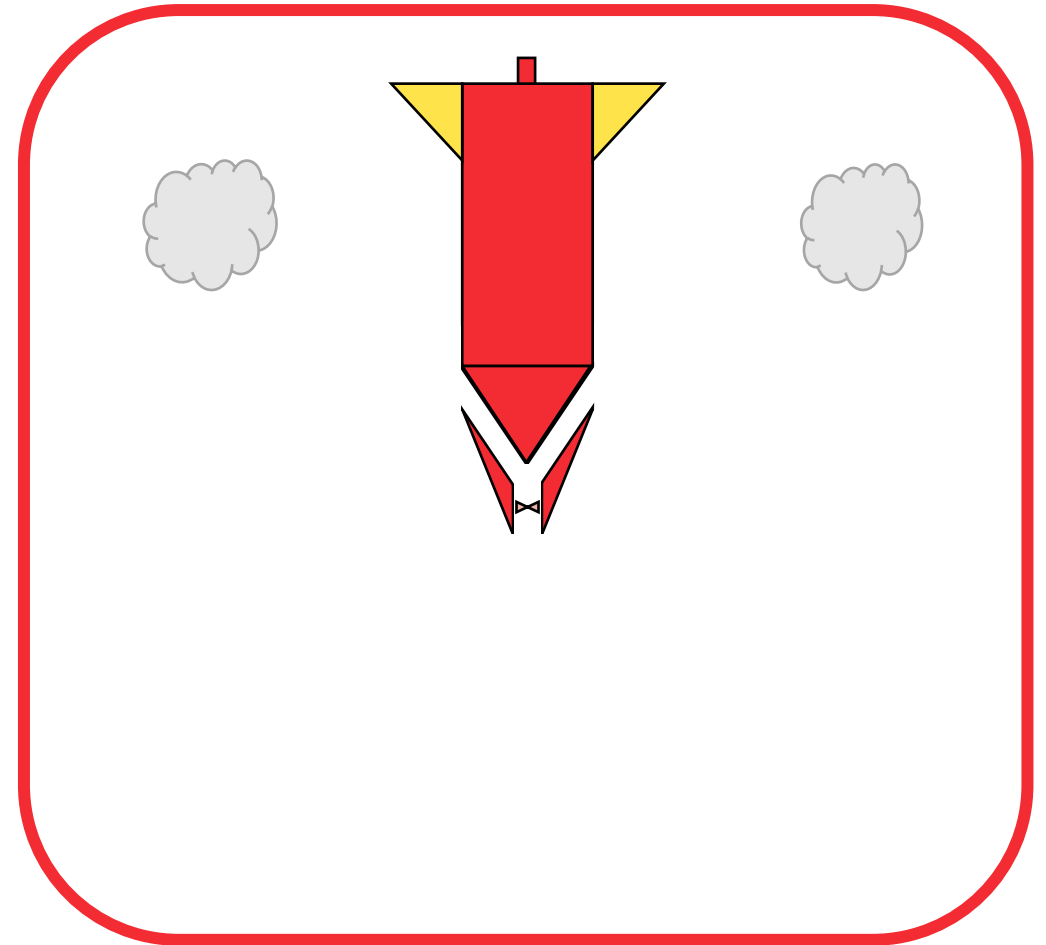
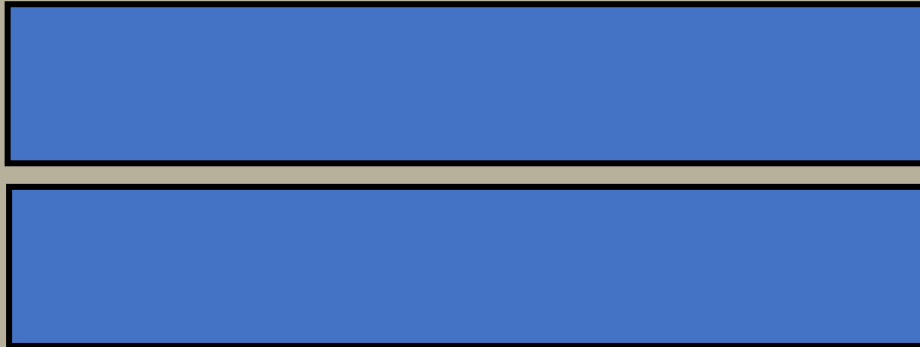

Thomas Lenz

Selected Design: Ducted Fan

Combats drag effects in two ways

1. Reduces differential pressure acting on the body

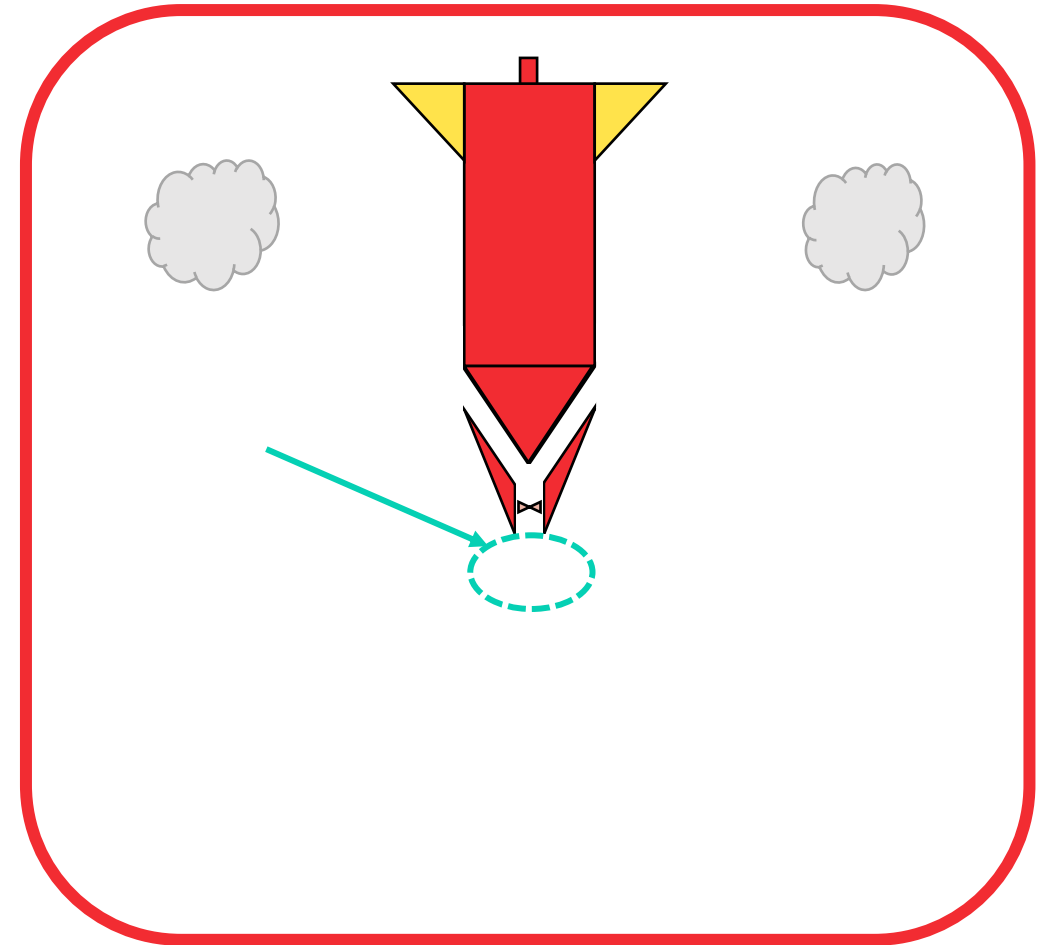

Thomas Lenz

Selected Design: Ducted Fan

Combats drag effects in two ways

1. Reduces differential pressure acting on the body

2. Provides sufficient thrust to counteract drag forces

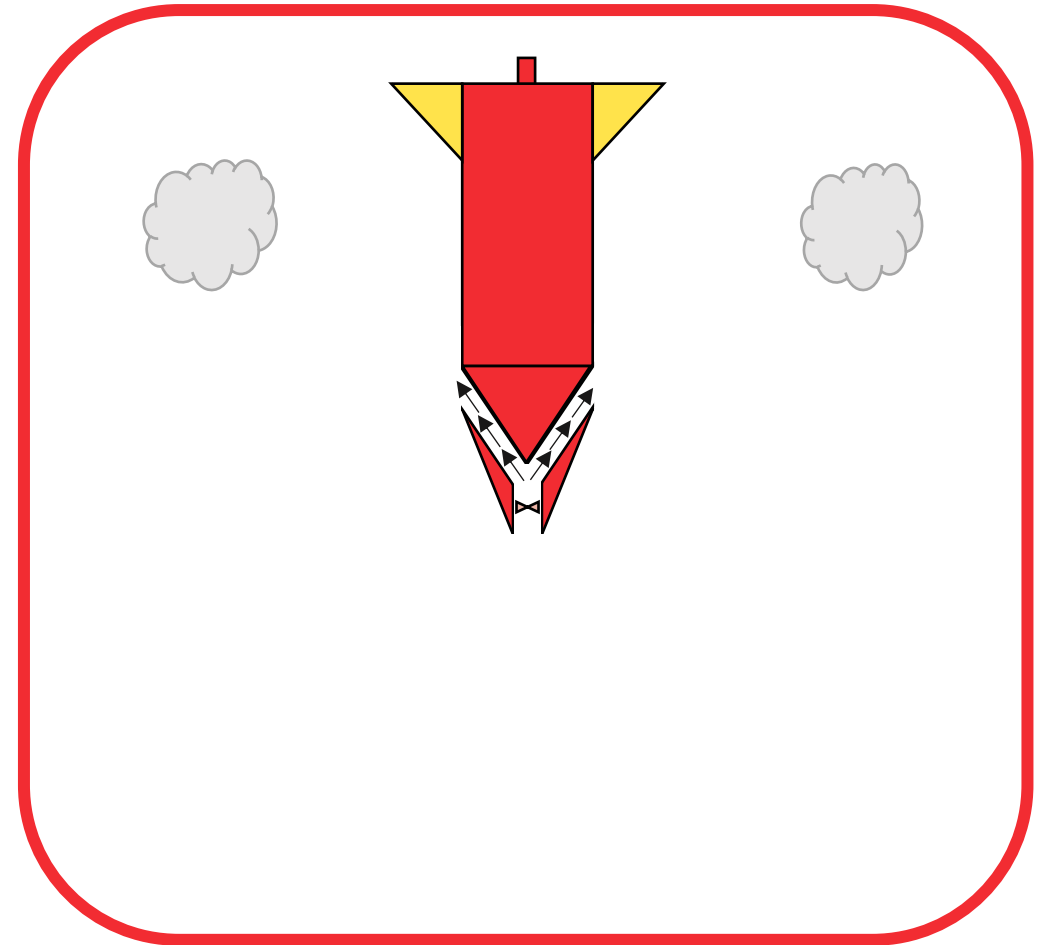

Thomas Lenz

Section View: Ducted Fan

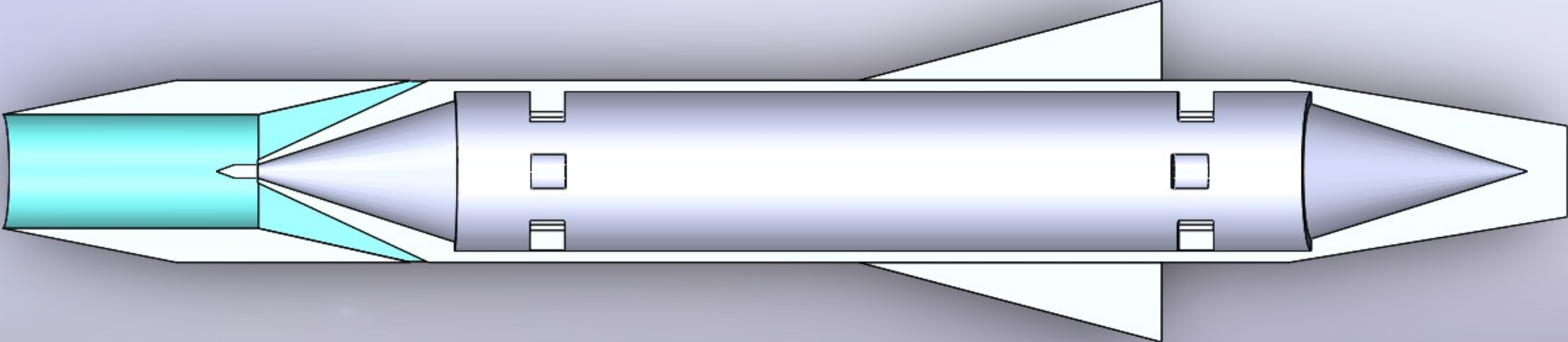

Thomas Lenz

Transparent View: Ducted Fan

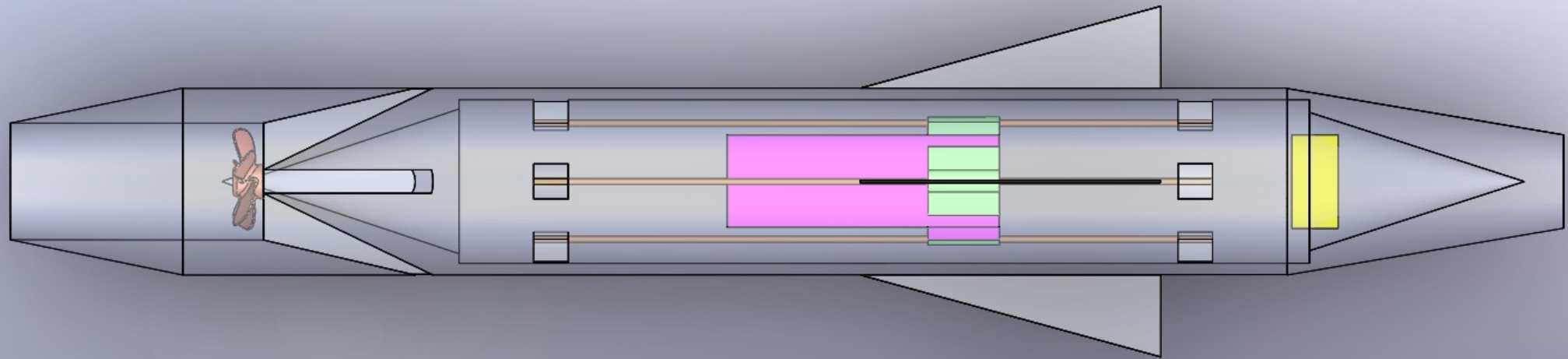

Thomas Lenz

Selected Design: Ducted Fan

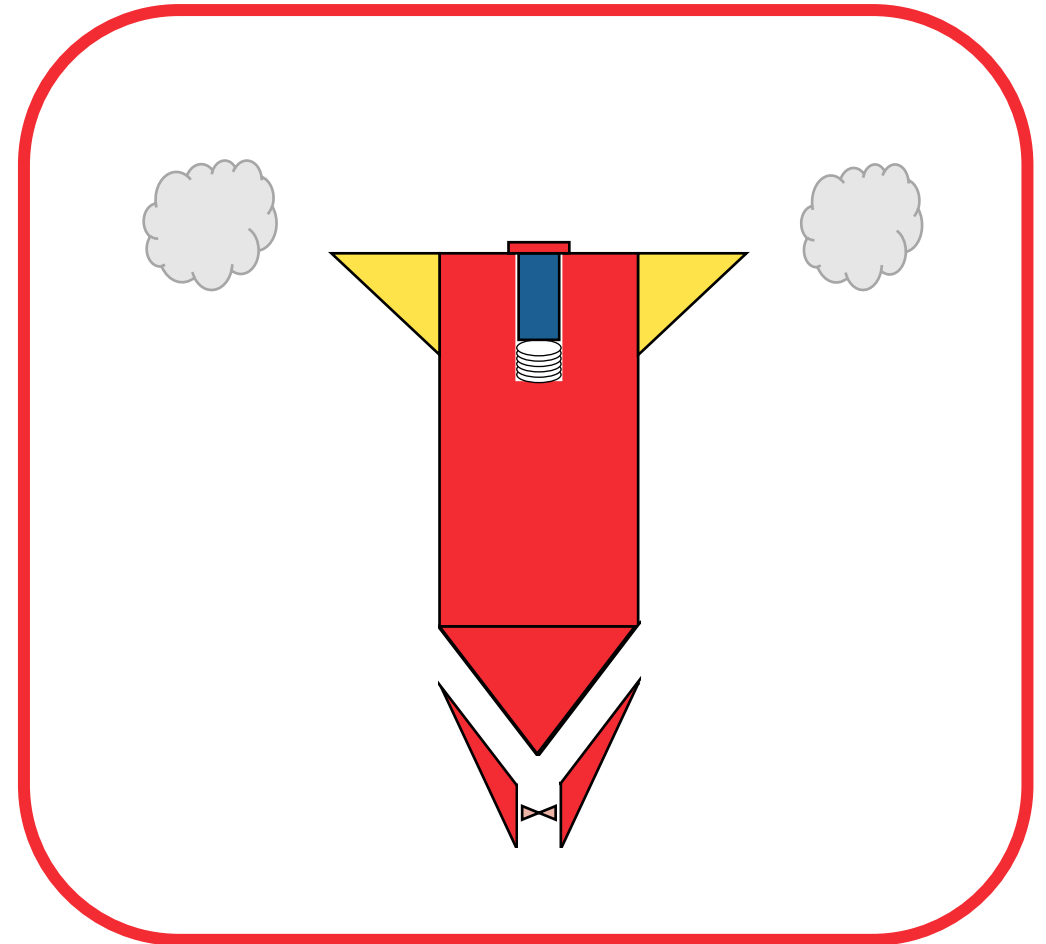
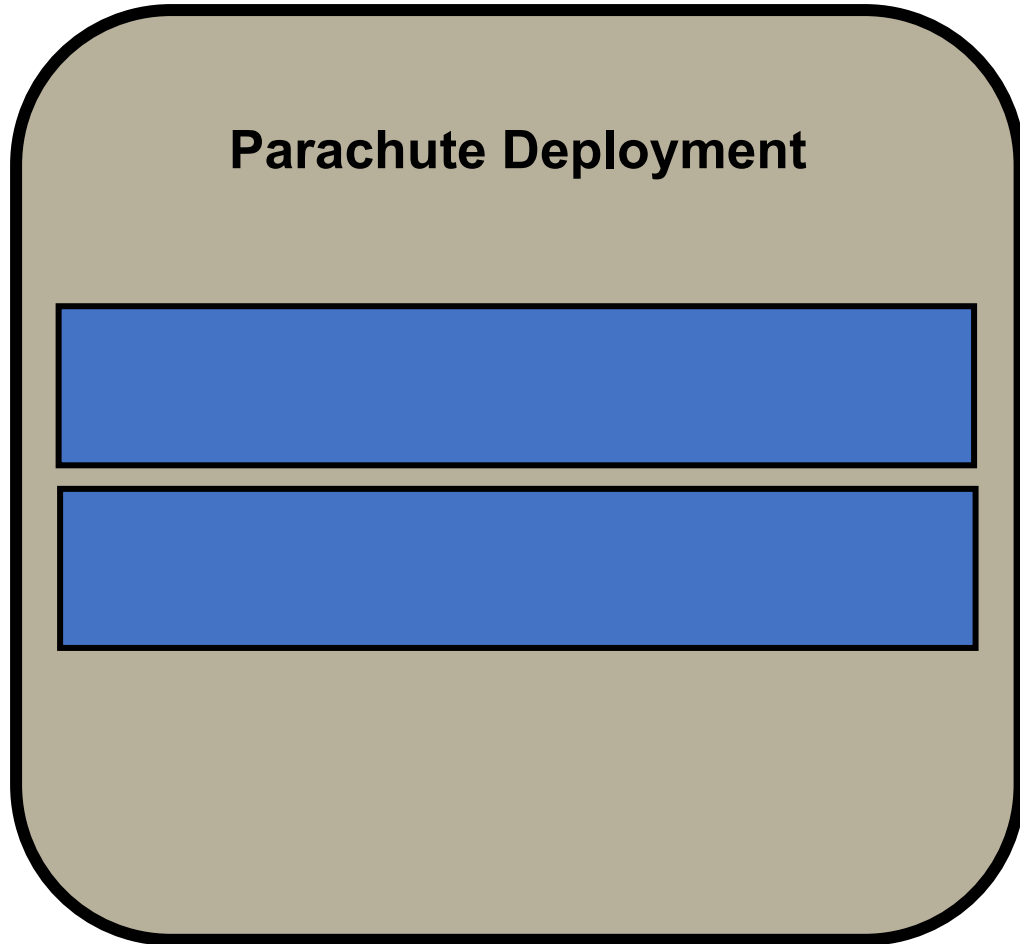

Thomas Lenz

Selected Design: Ducted Fan

Parachute Deployment

1. A spring ejects the parachute from the back

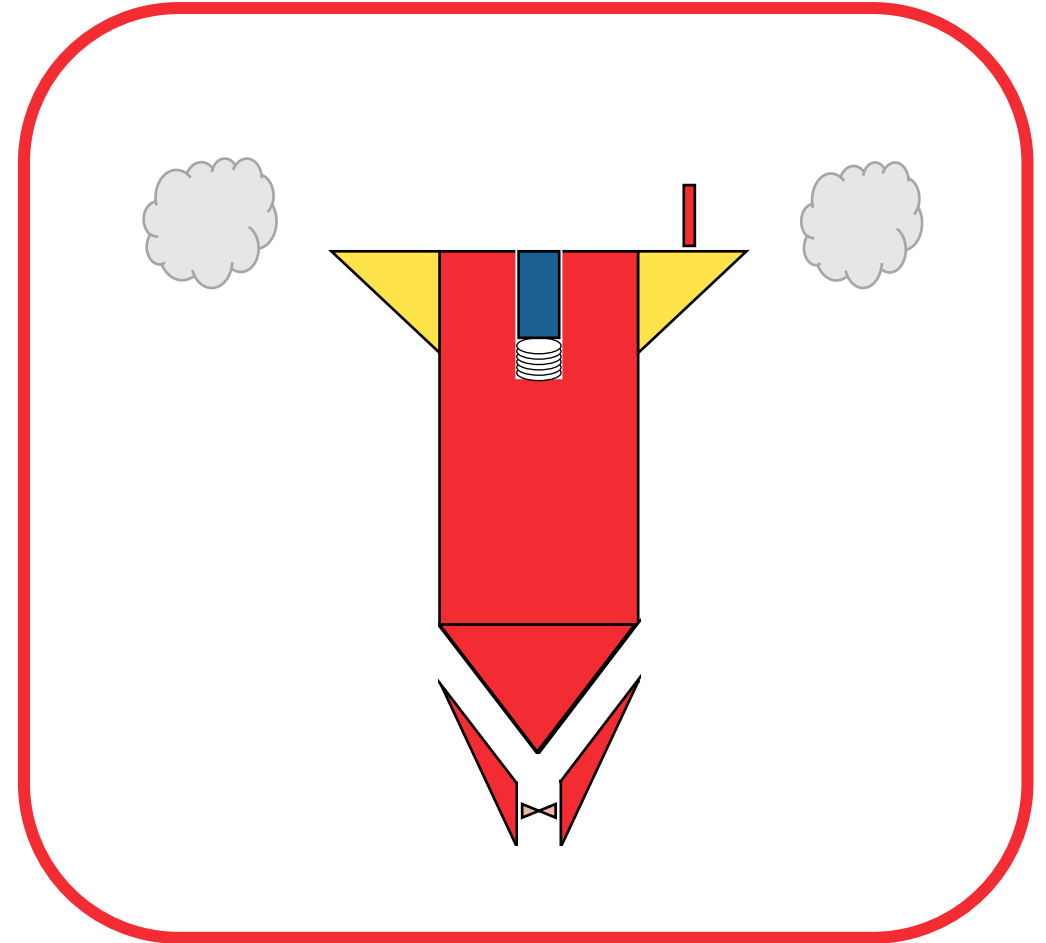

Thomas Lenz

Selected Design: Ducted Fan

Parachute Deployment

1. A spring ejects the parachute from the back

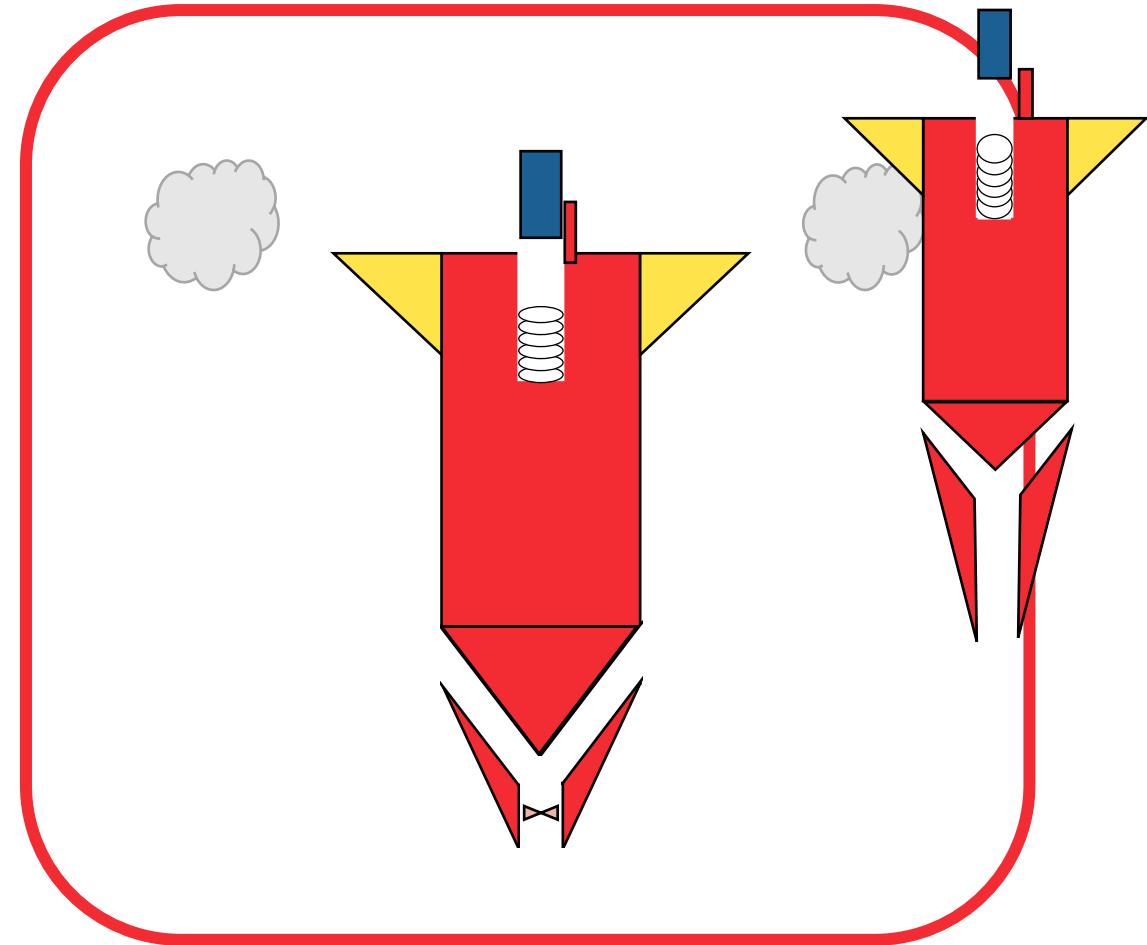

Thomas Lenz

Selected Design: Ducted Fan

Parachute Deployment

1. A spring ejects the parachute from the back

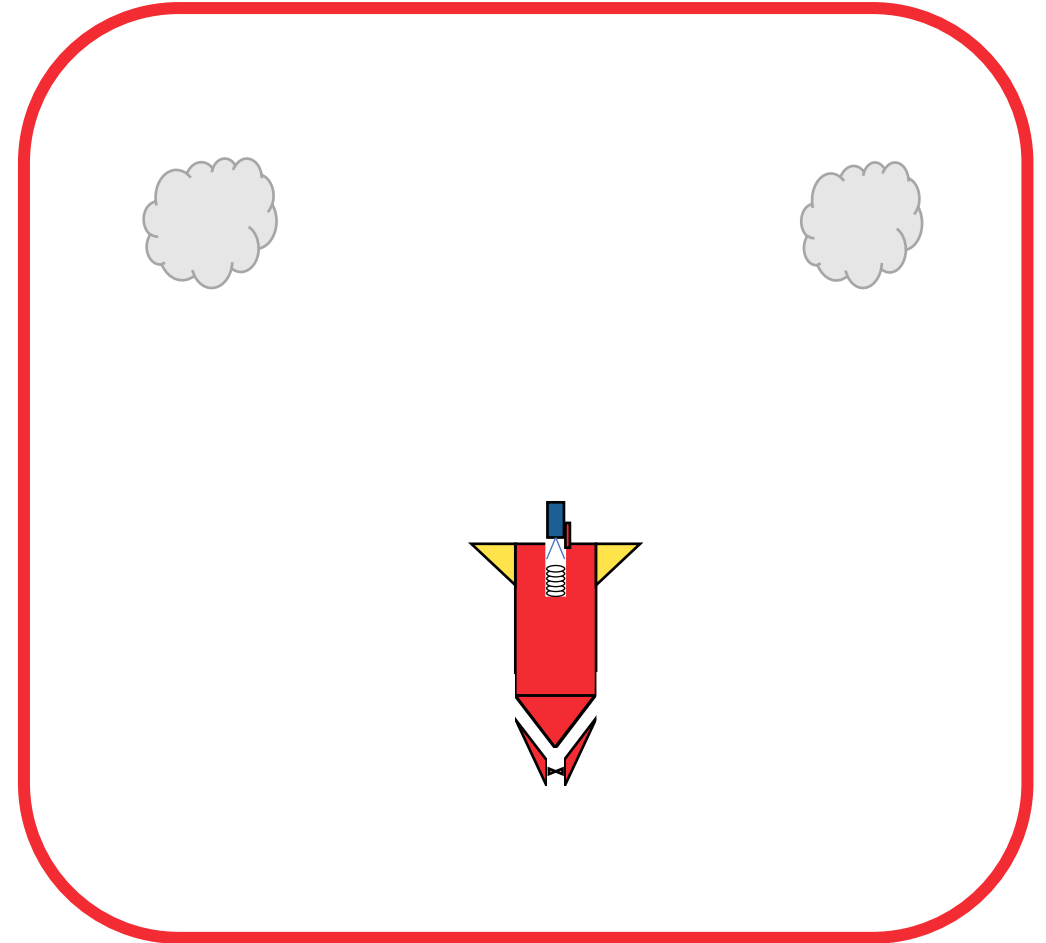

Thomas Lenz

Selected Design: Ducted Fan

Parachute Deployment

1. A spring ejects the parachute from the back

2. The parachute expands

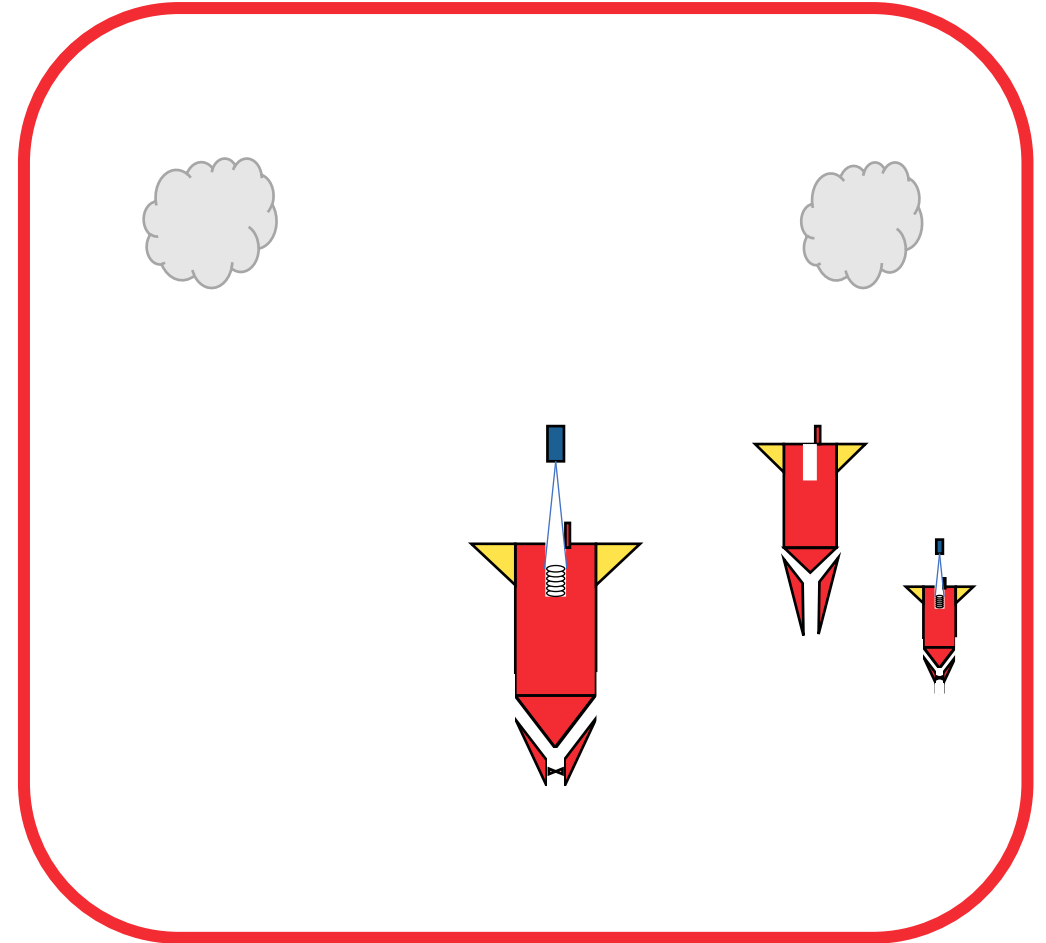

Thomas Lenz

Selected Design: Ducted Fan

Parachute Deployment

1. A spring ejects the parachute from the back

2. The parachute expands

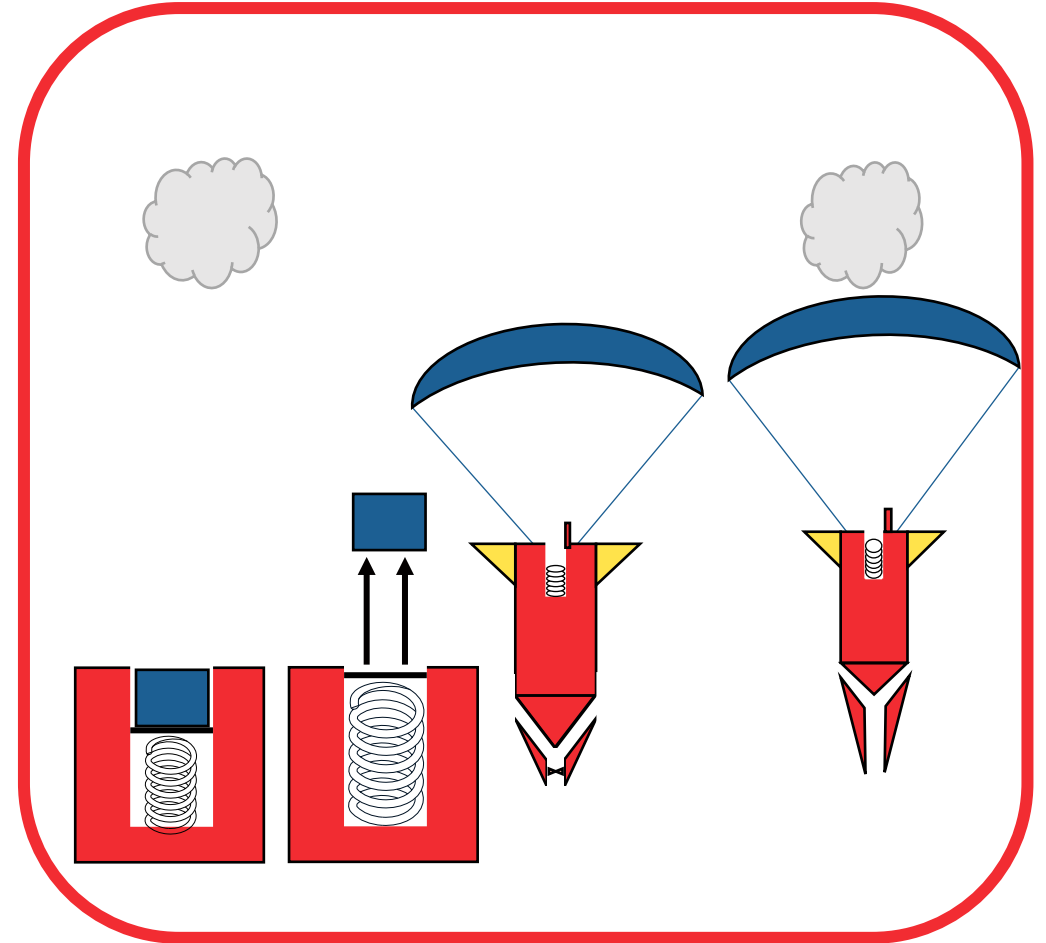

Thomas Lenz

Future Work

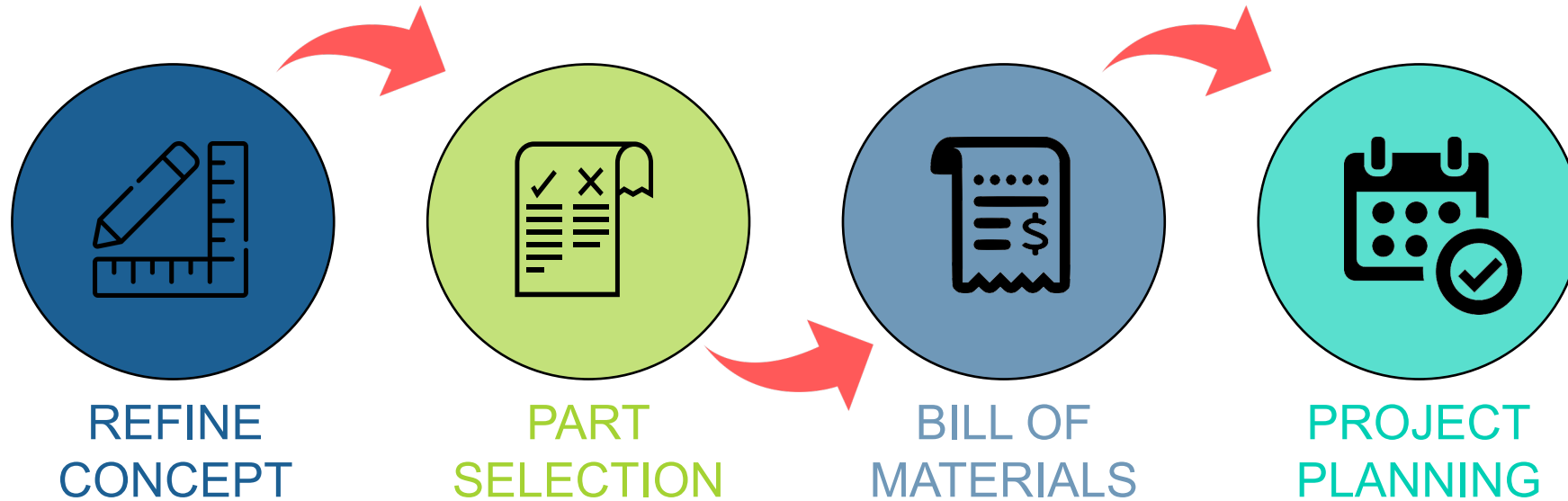

Thomas Lenz

Future Work

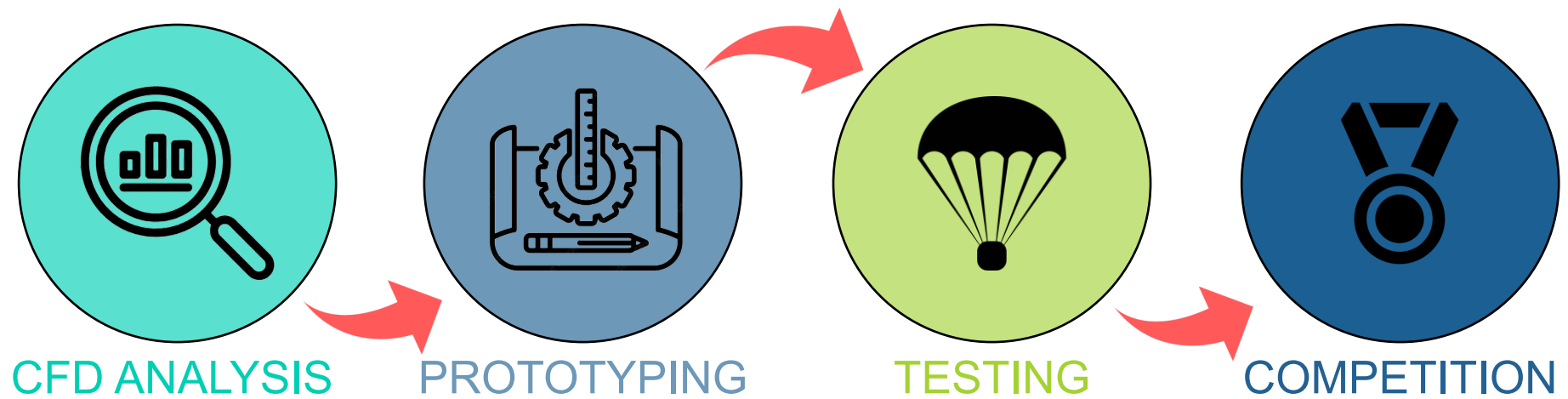

Thomas Lenz

References

Images:

<https://thekidshouldseethis.com/post/feathered-fighter-jets-peregrine-falcons>

https://www.esa.int/ESA_Multimedia/Images/2007/11/Zero-G_Airbus_A300_for_parabolic_flights

https://en.wikipedia.org/wiki/Sounding_rocket

https://www.esa.int/ESA_Multimedia/Images/2017/03/ZARM_s_Drop_Tower_in_Bremen

<https://www.hitec.uni-hannover.de/en/large-scale-equipment/einstein-elevator/>

<https://www.hitec.uni-hannover.de/en/large-scale-equipment/einstein-elevator/events-and-media/>

Further Readings:

<https://www.gozerog.com/>

https://www.nasa.gov/mission_pages/sounding-rockets/missions/index.html

<https://www.zarm.uni-bremen.de/en/drop-tower/general-information.html>

<https://www.hitec.uni-hannover.de/en/large-scale-equipment/einstein-elevator>

https://www.youtube.com/watch?v=4aCMDQsx740&ab_channel=TomScott

Thomas Lenz