

Team 506: Corning Plugger Pallet Short Part Stabilization

Pawel J. Grum | Robert C. Kosmas | Taylor M. Larson | Segundo A. Sanchez | Jared T. White

Team Members



Pawel J.
Grum

*Mechanical Test
Engineer*



Robert C.
Kosmas

*Structural Design
Engineer*



Taylor M.
Larson

*Dynamics
Engineer*



Segundo A.
Sanchez

*Materials Analysis
Engineer*



Jared T.
White

*Manufacturing
Engineer*

Segundo Sanchez



Sponsors and Advisors

Jeffery Roche



Engineering Mentor

*Heavy Duty Project
Manager*

Jeffery Stott



Engineering Mentor

*Equipment Engineering
Manager*

Eric Hellstrom, Ph.D



Academic Advisor

*Materials Science
Program Director*

Segundo Sanchez

Background

Segundo Sanchez



Project Objective

The objective of this project is to produce a stabilization system to protect ceramics on Corning's conveyor while reducing the required manual labor.

Segundo Sanchez



Project Background



Segundo Sanchez

Key Goals

Prevent Damage



Limit Interaction

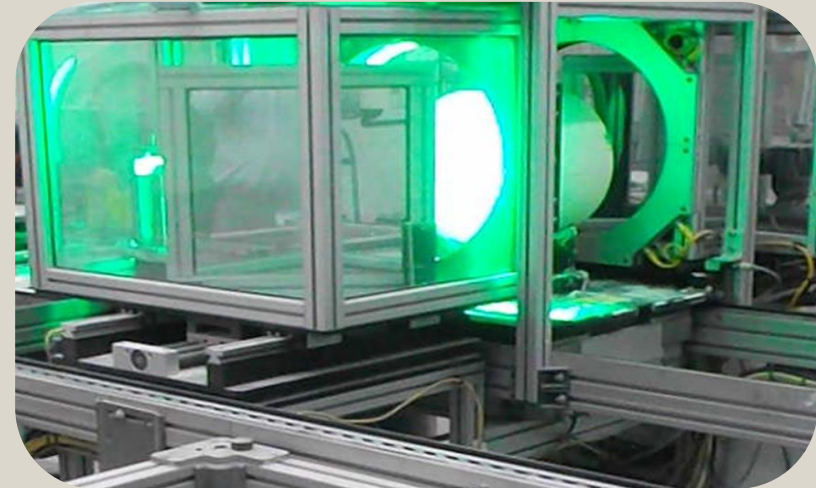

Segundo Sanchez

Key Goals

Integrate with Conveyor System

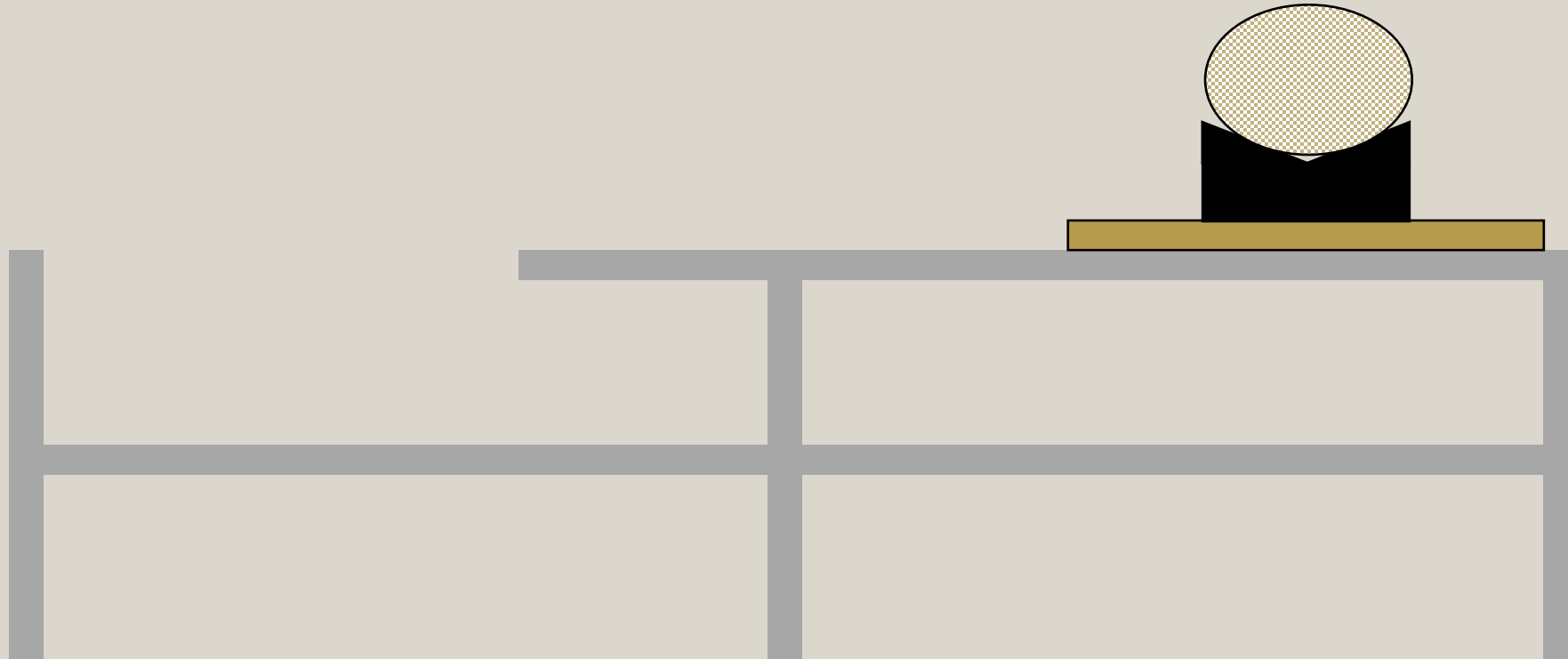

Segundo Sanchez

Critical Targets

Prevent Damage
0%

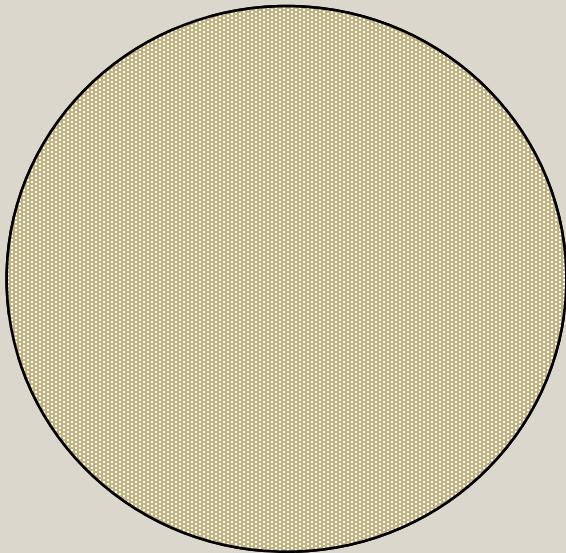

Limit Manual Labor
1 Person

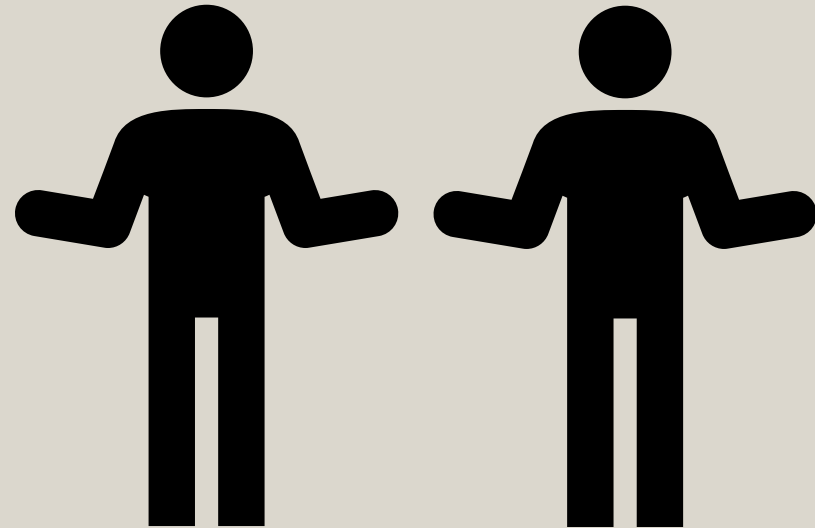

Segundo Sanchez

Critical Targets

Withstand Load
8 lbs

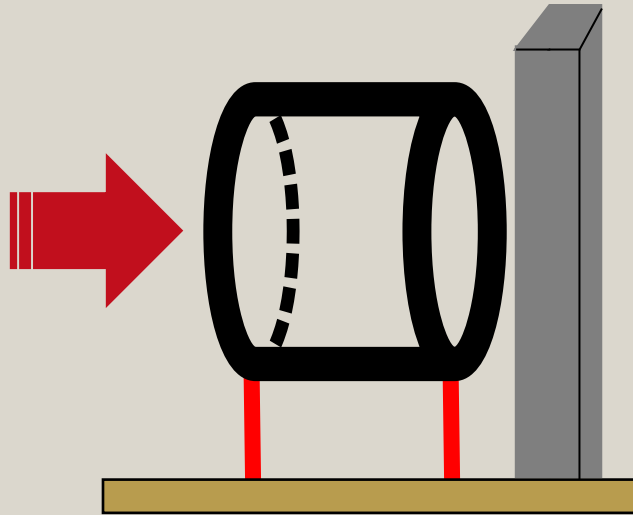

Reveal Ceramic Face
48 sec

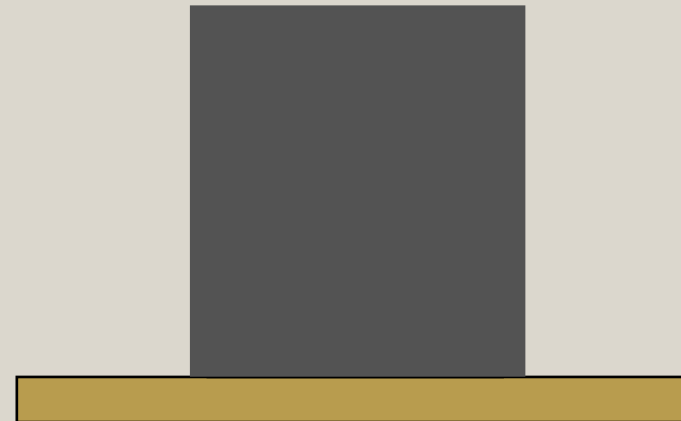

Segundo Sanchez

Top 3 Concepts Generated

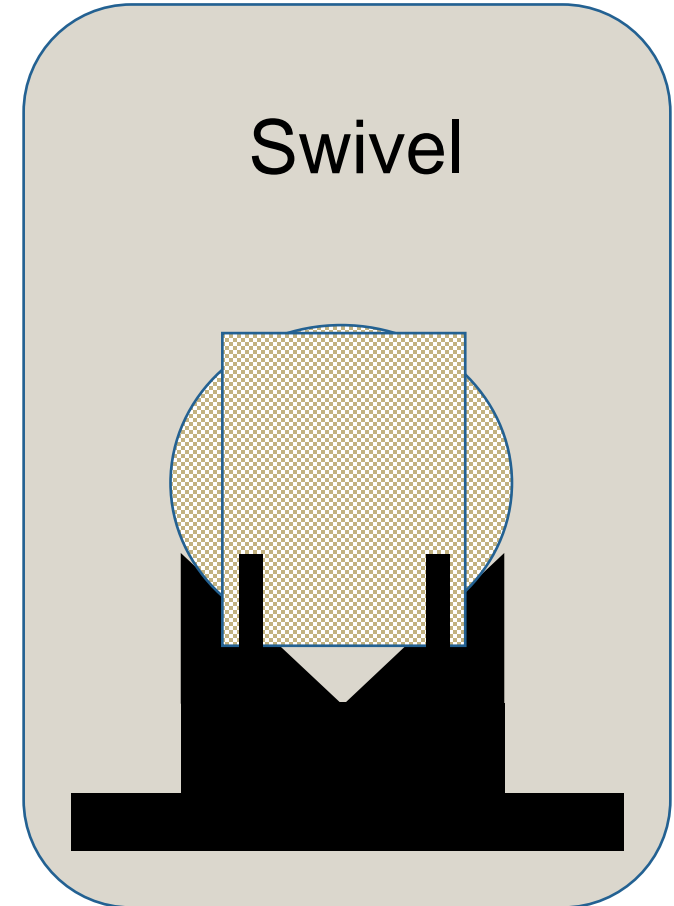
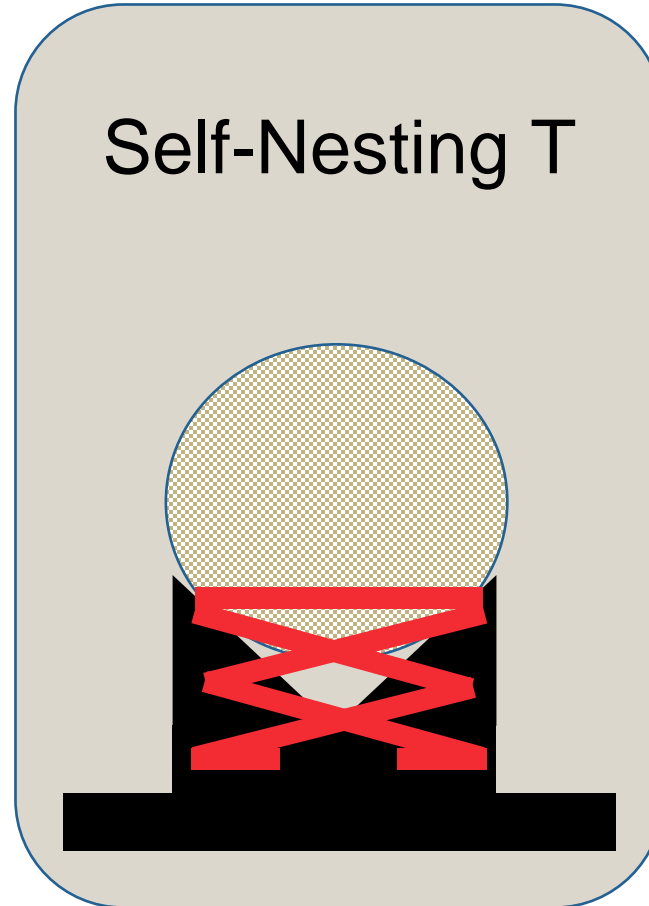
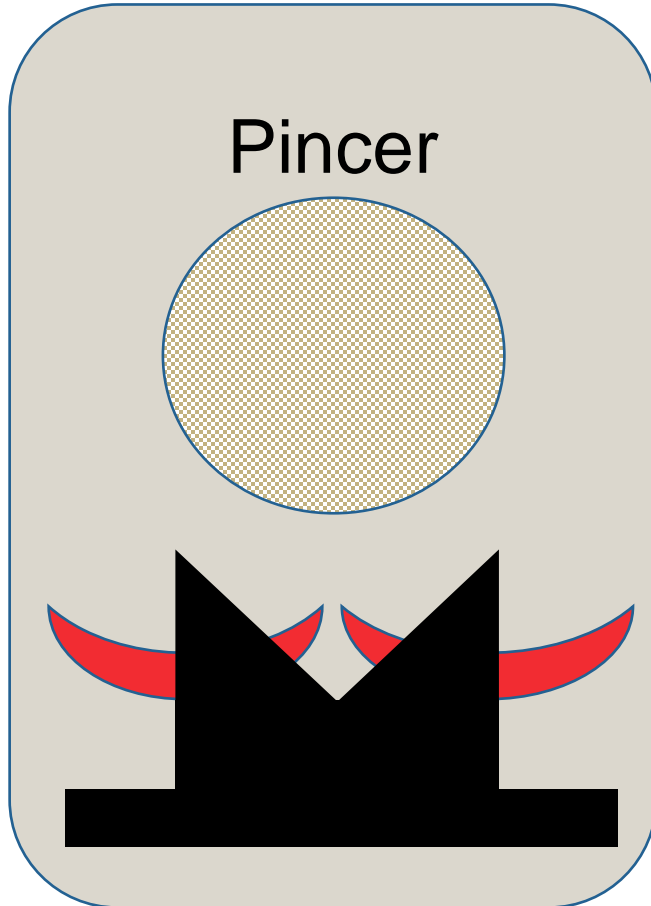

Segundo Sanchez

Concept Selection

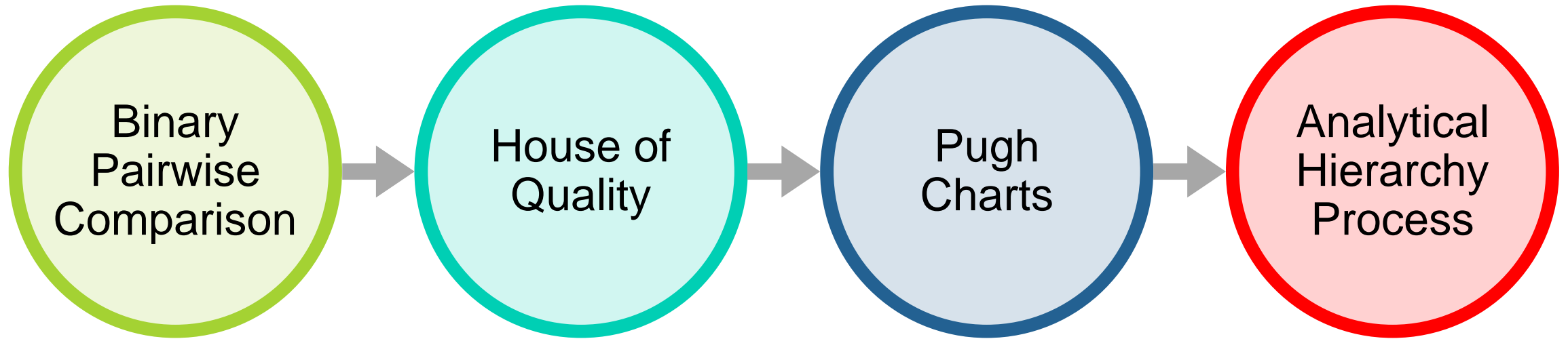

Segundo Sanchez

Final Selection

Self-Nesting T

- Similar to working design
- Trigger activated and collapsible
- Uses mechanism on conveyor to activate



Segundo Sanchez



Background



Lift Mechanism

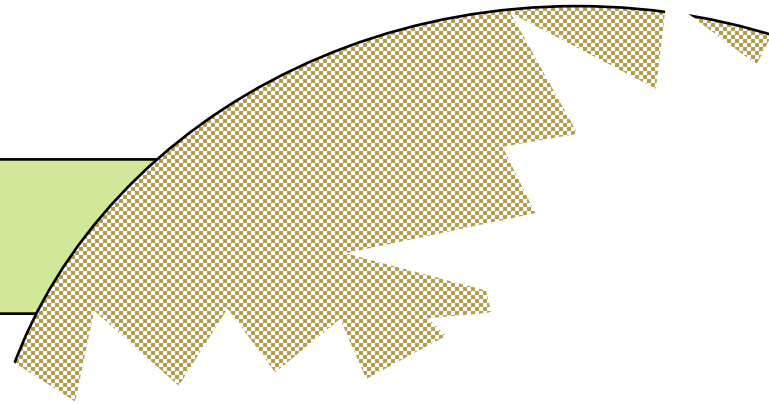

Design Update

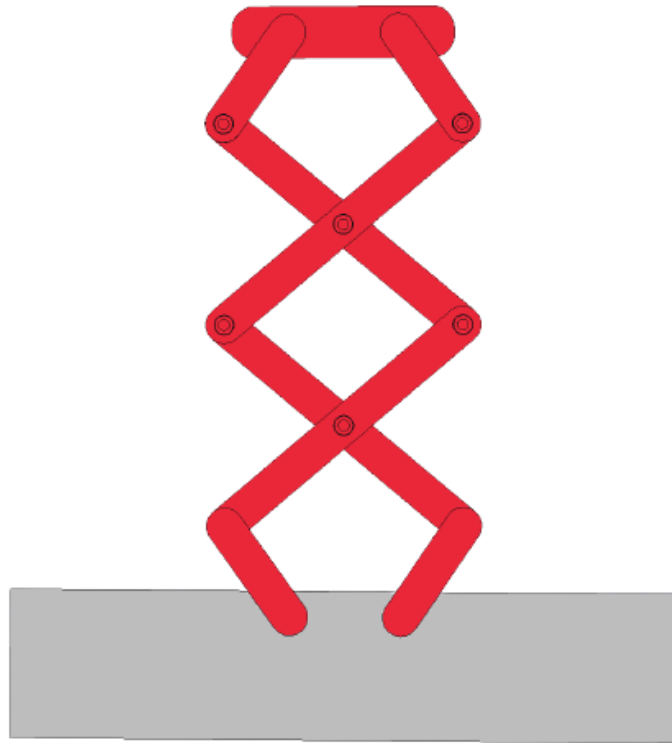

Original Design

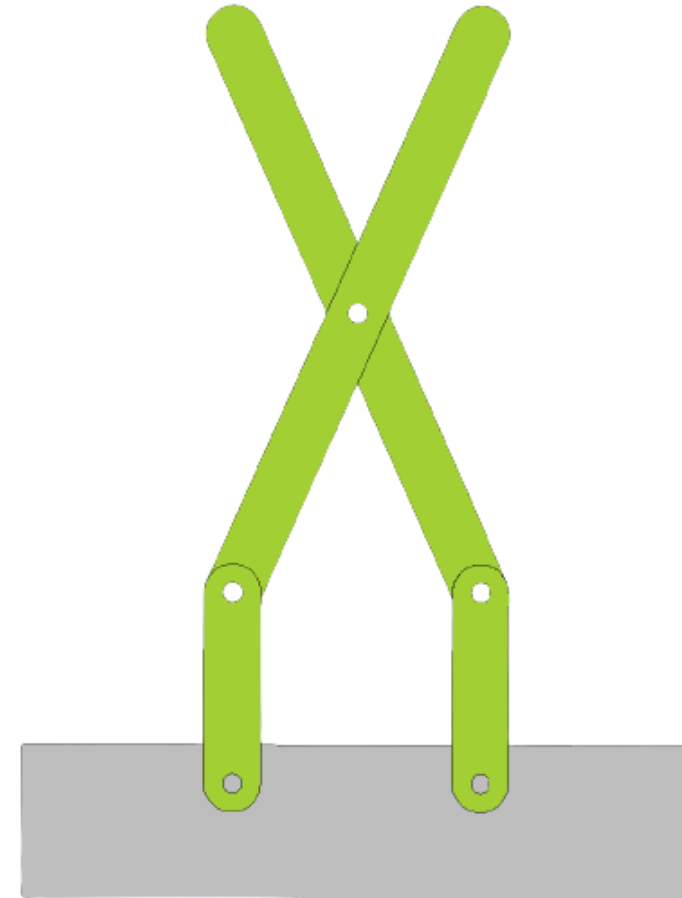

Current Design

Jared White

Vertical Retraction and Expansion

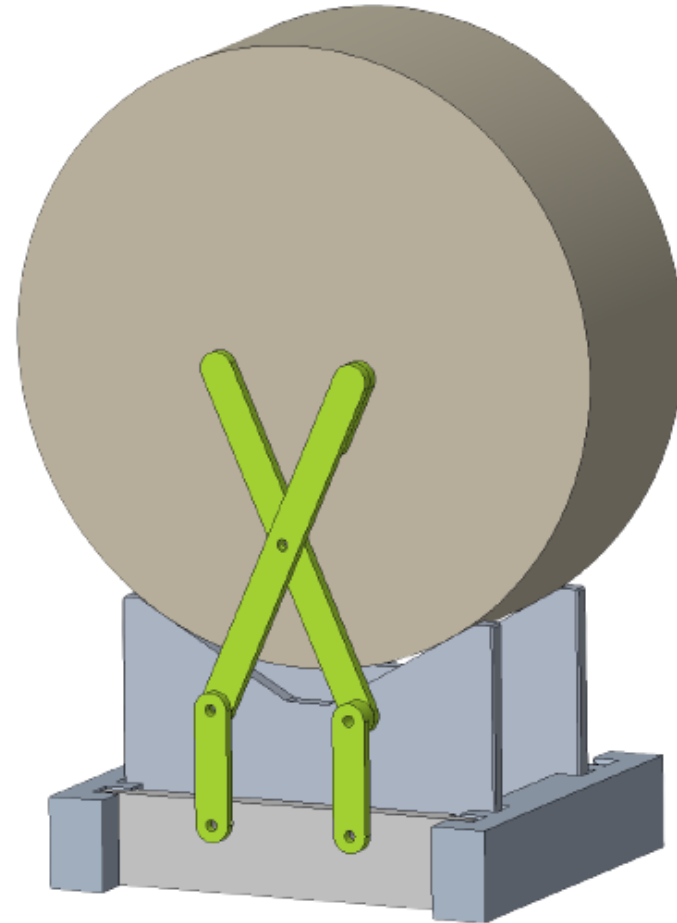
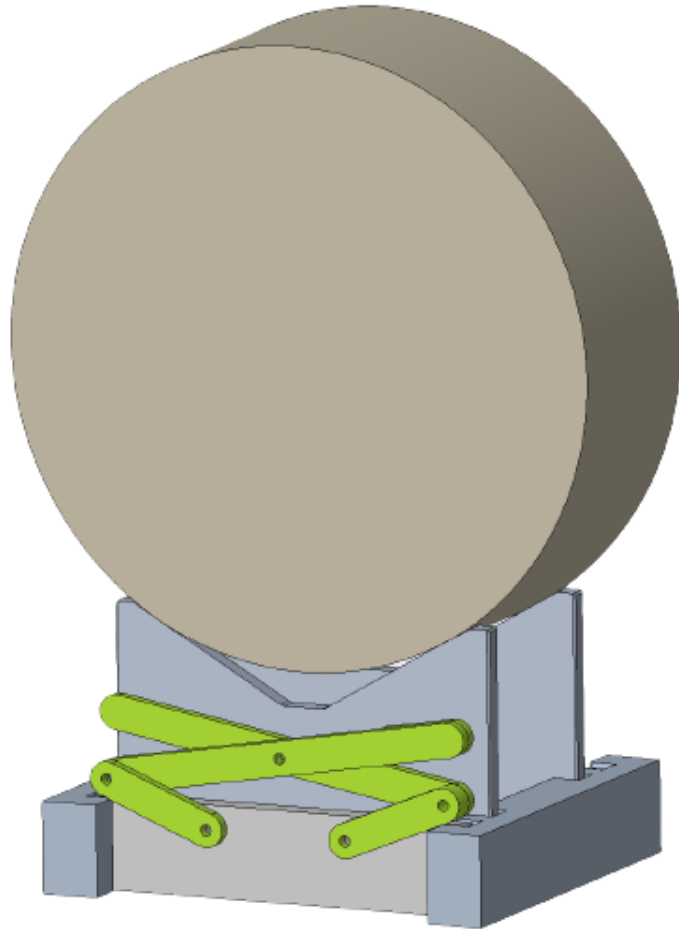

Jared White

Vertical Retraction and Expansion

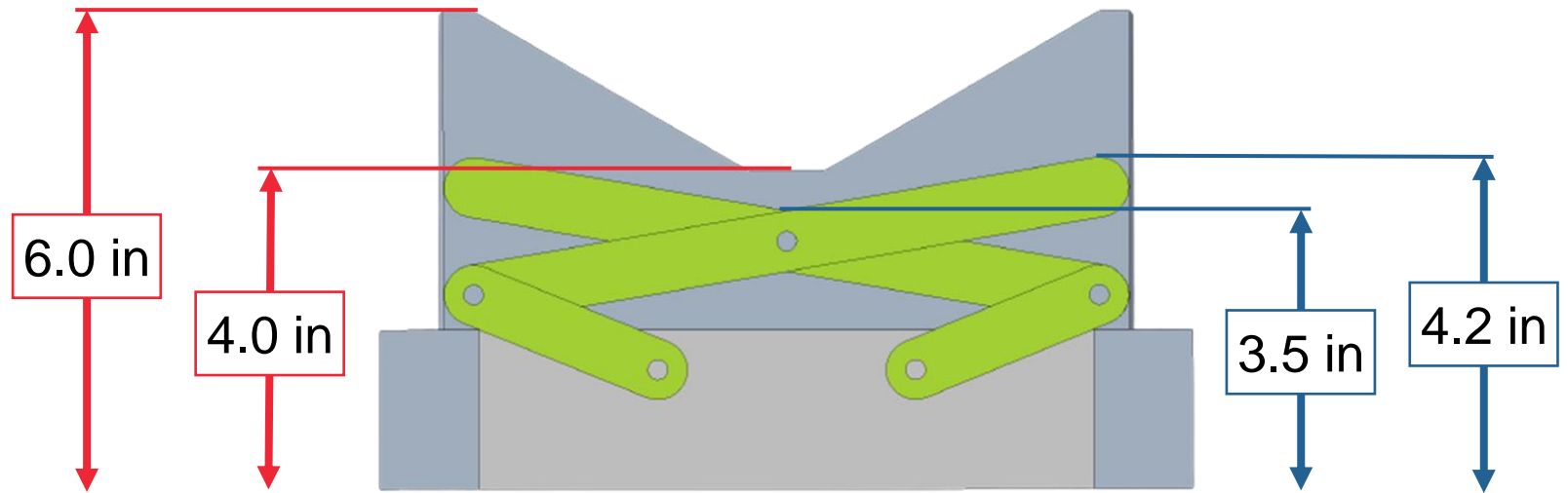
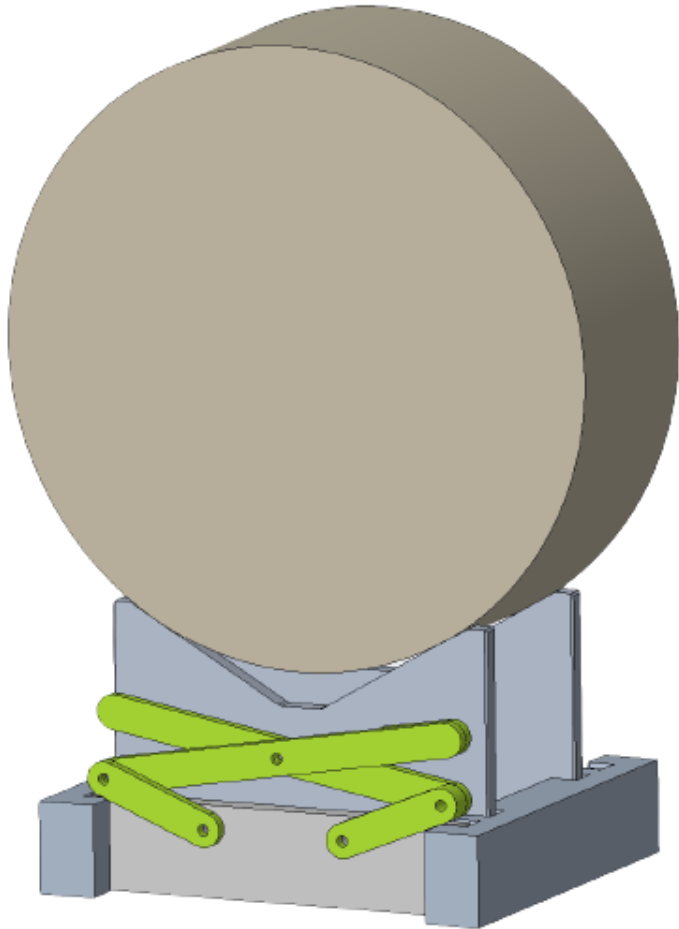

Jared White

Vertical Retraction and Expansion

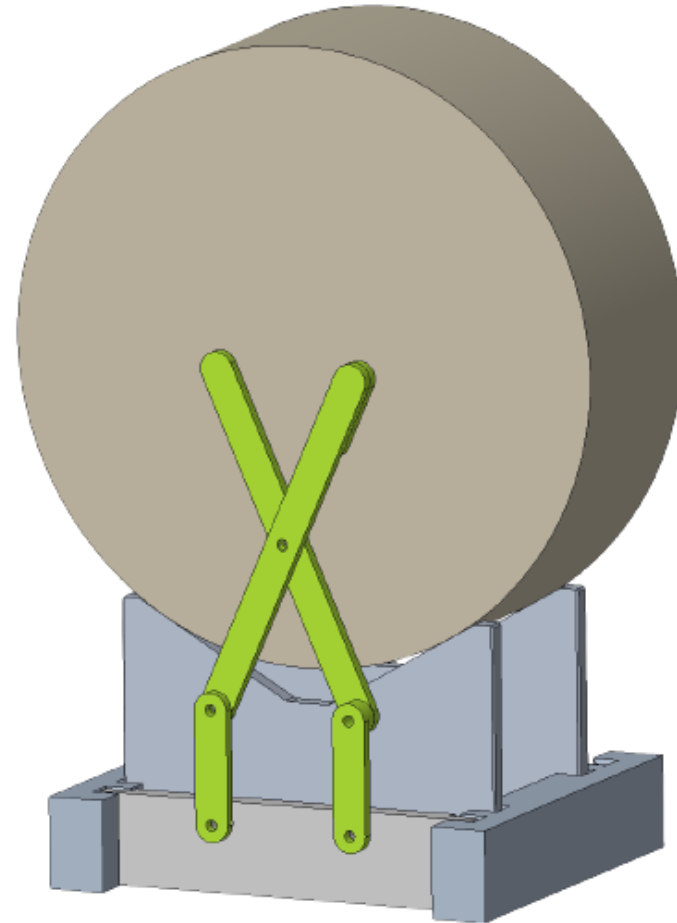
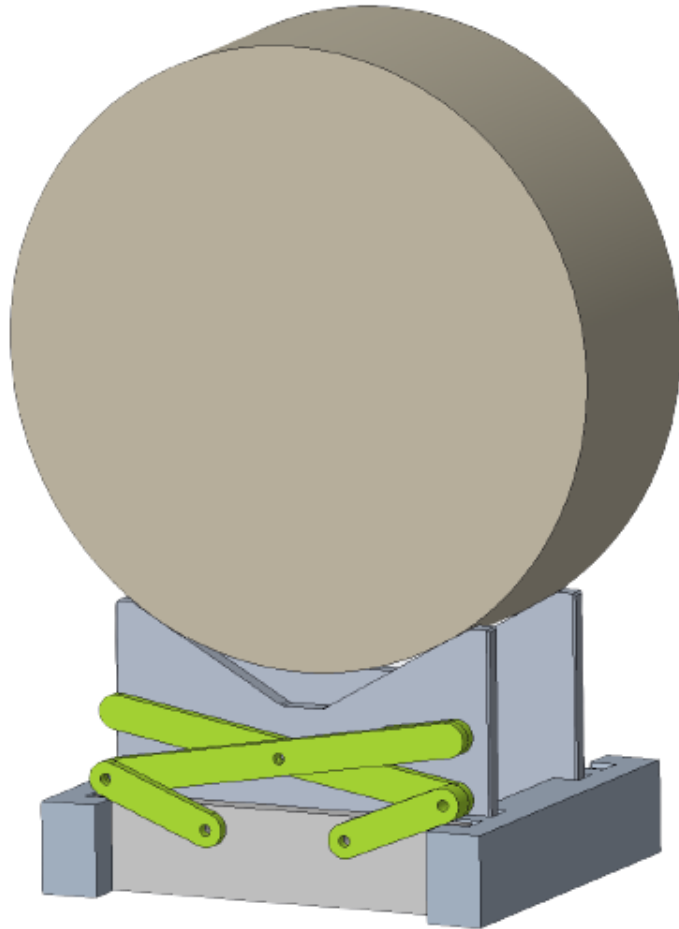

Jared White

Vertical Retraction and Expansion

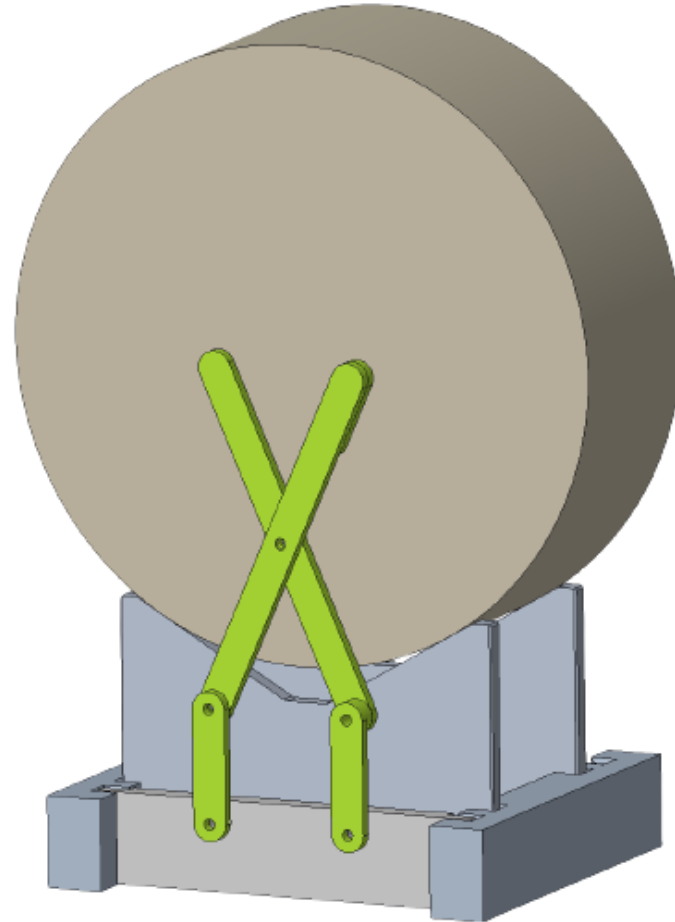
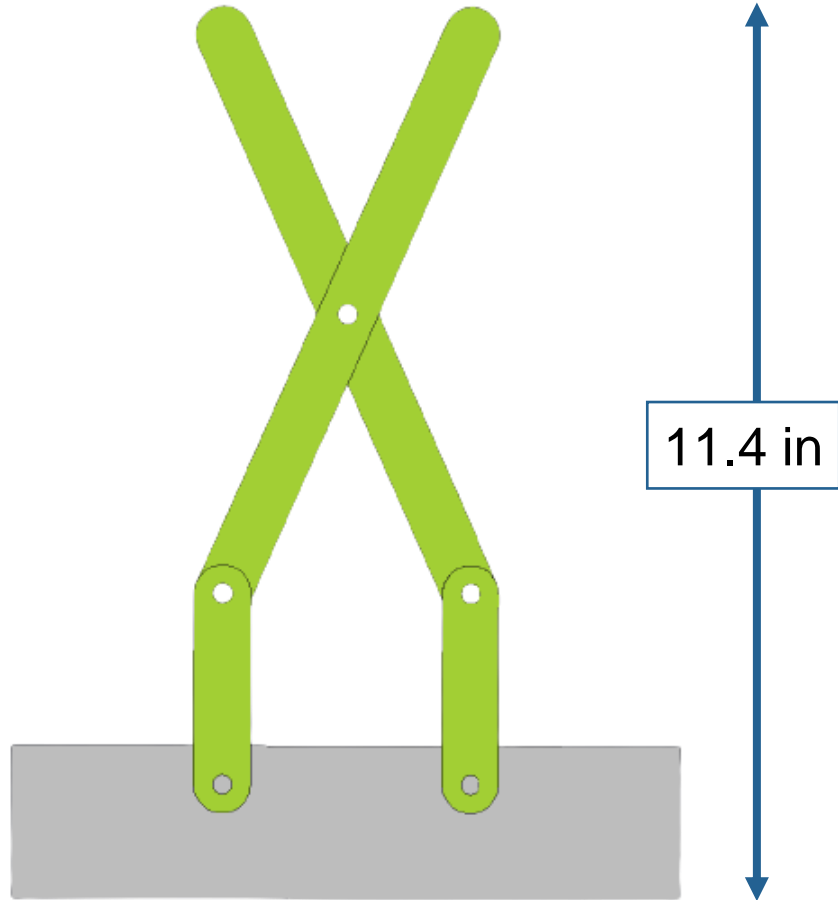

Jared White

Background

Lift Mechanism

Actuation

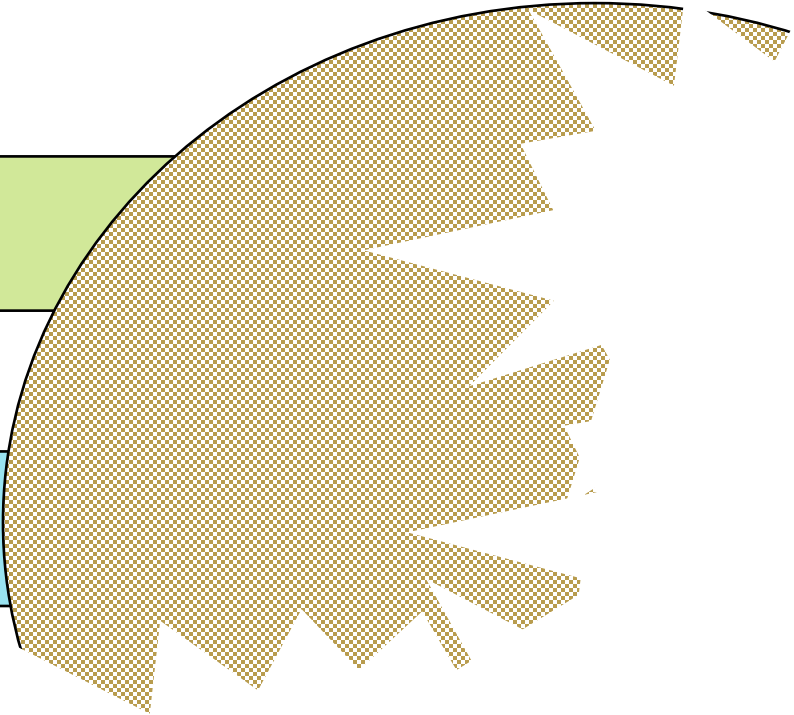

Jared White

Vertical Retraction and Expansion

Gear and Rack Slider

- “Z” shaped rack allows simultaneous rotation
- Slides in a slot on the outer wall
- Raised outer wall allows for particle flow

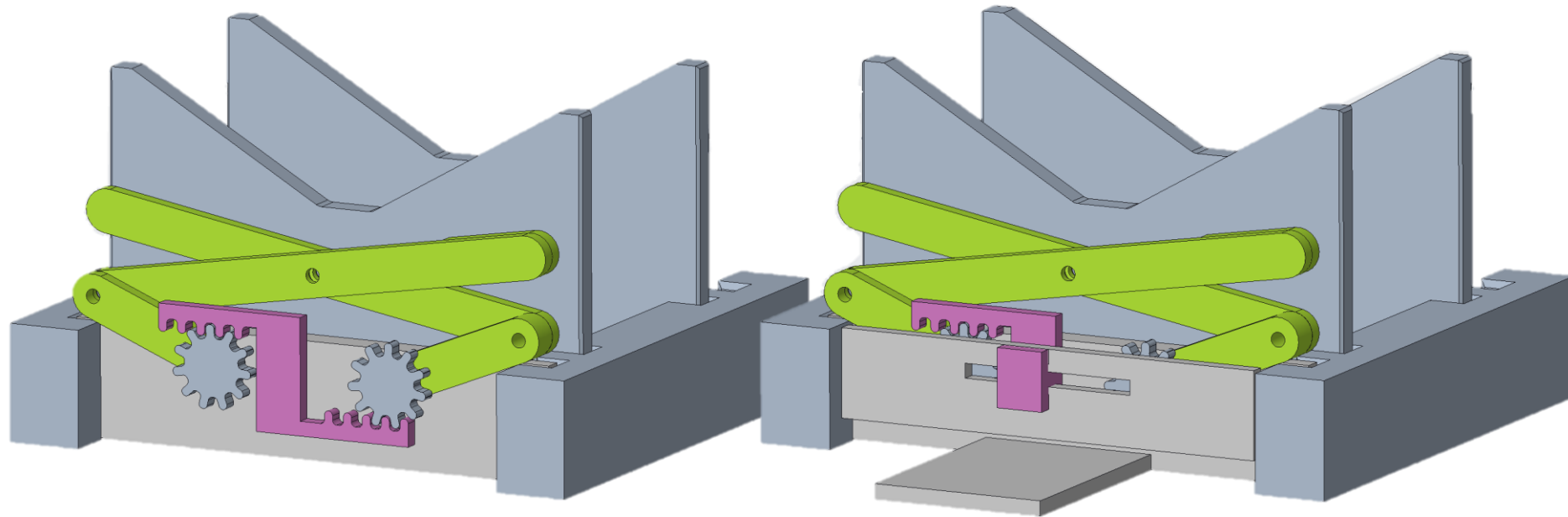

Jared White

Vertical Retraction and Expansion

Slider Joint and Switch

- The rack will act as a slider
- Slotted joint connection will allow for rotation of the switch

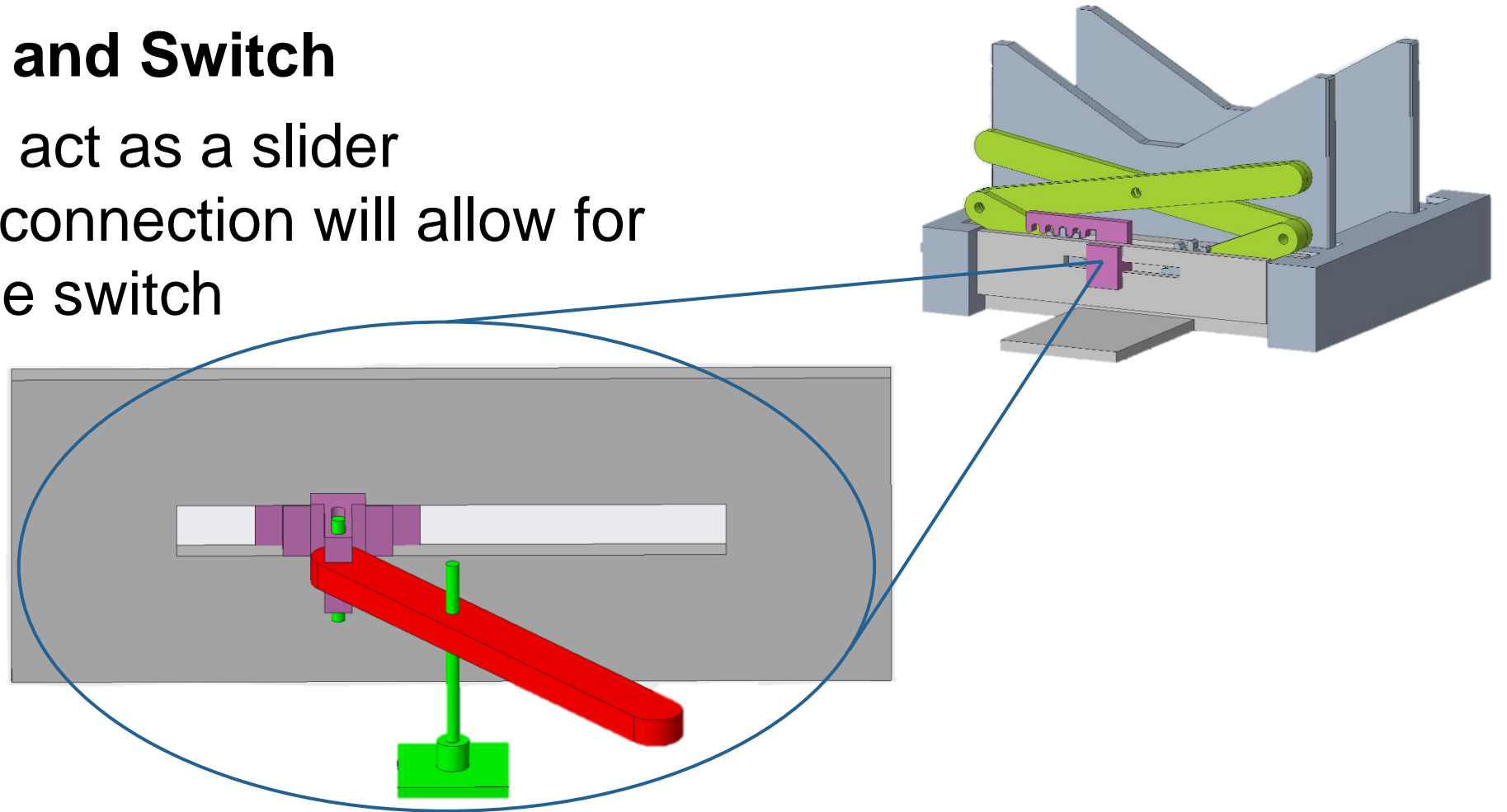

Jared White

Vertical Retraction and Expansion

Slider Joint and Switch

- The rack will act as a slider
- Slotted joint connection will allow for rotation of the switch

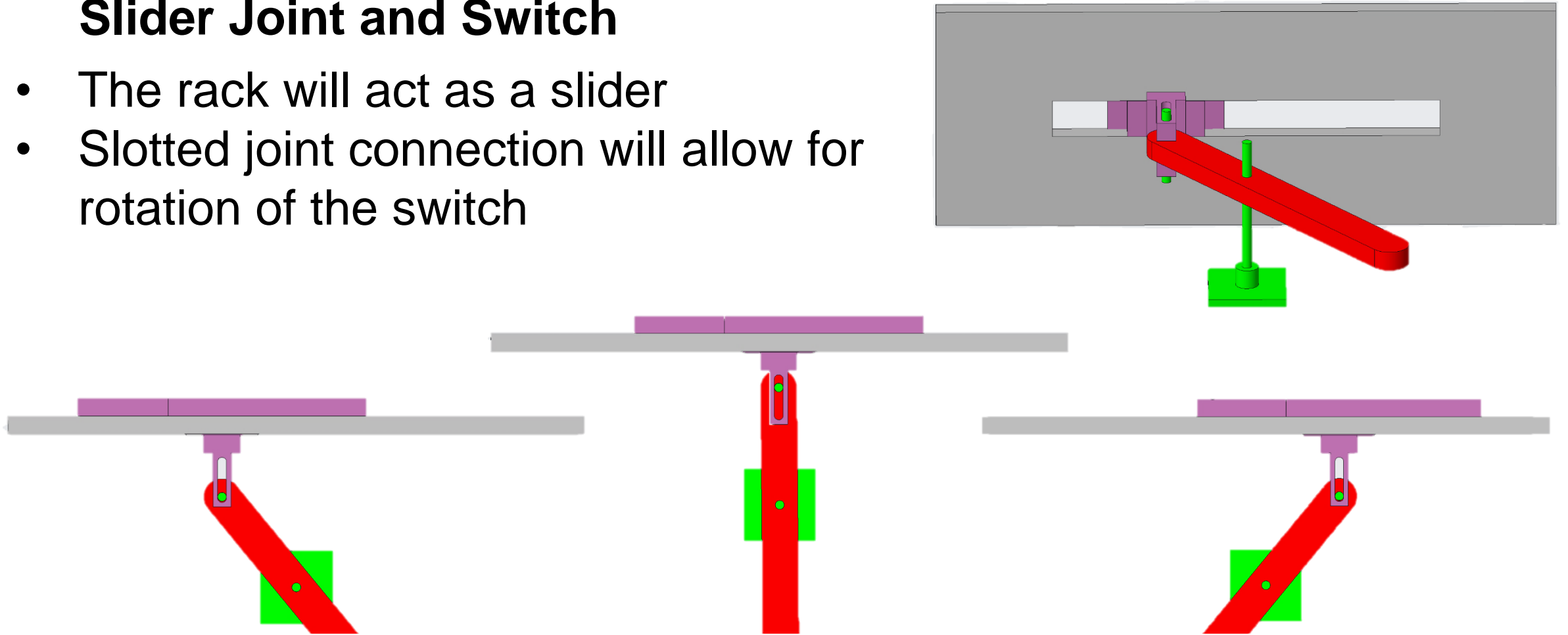

Jared White

Final Design

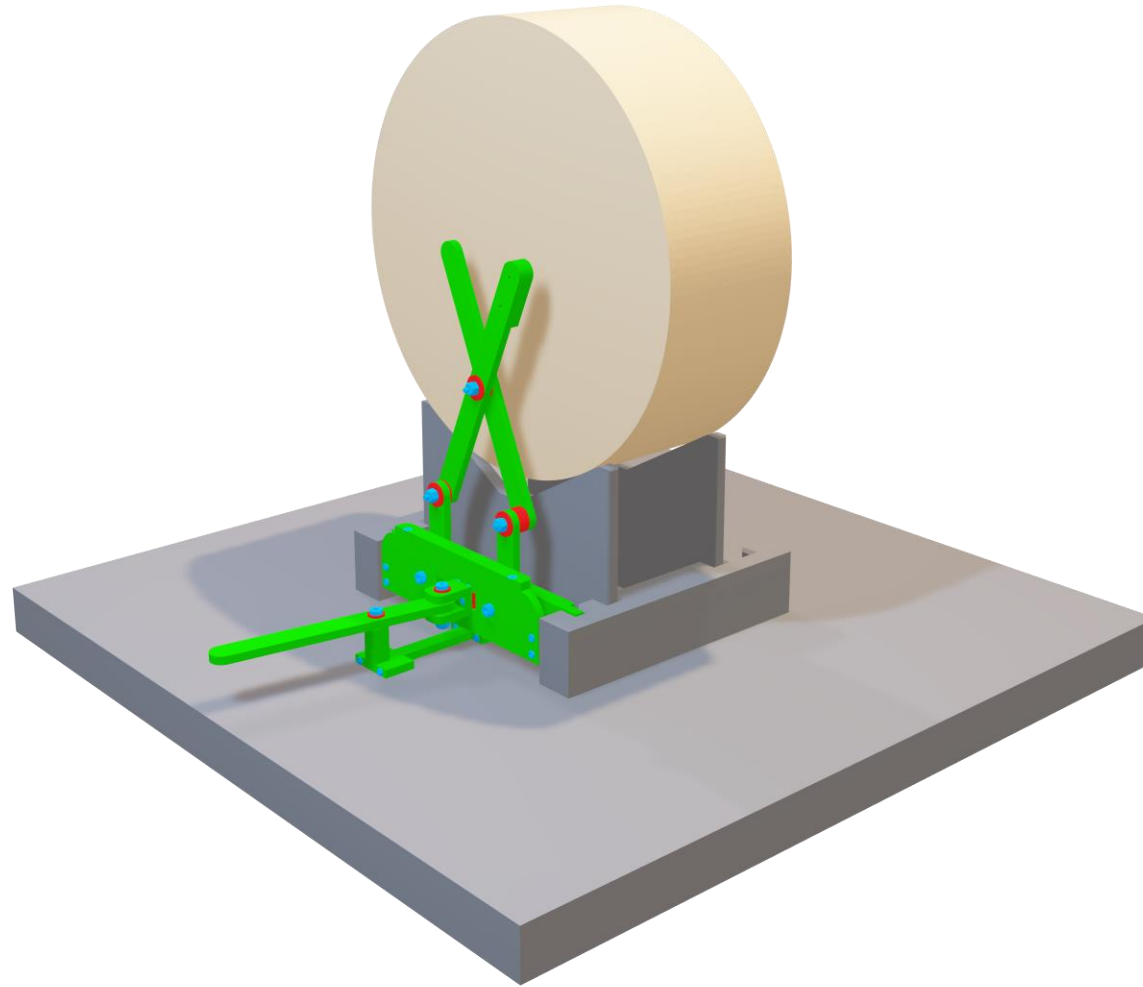

Jared White

Background

Lift Mechanism

Actuation

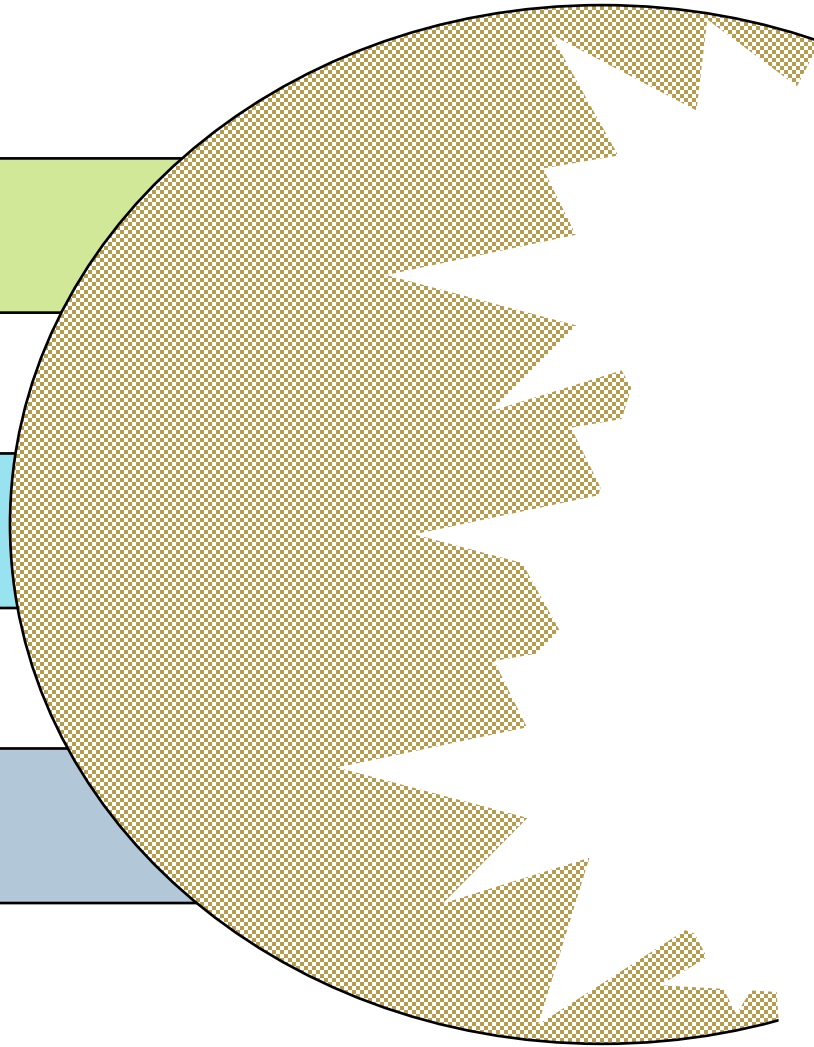

Overhang Design

Jared White

Overhangs

Full Design

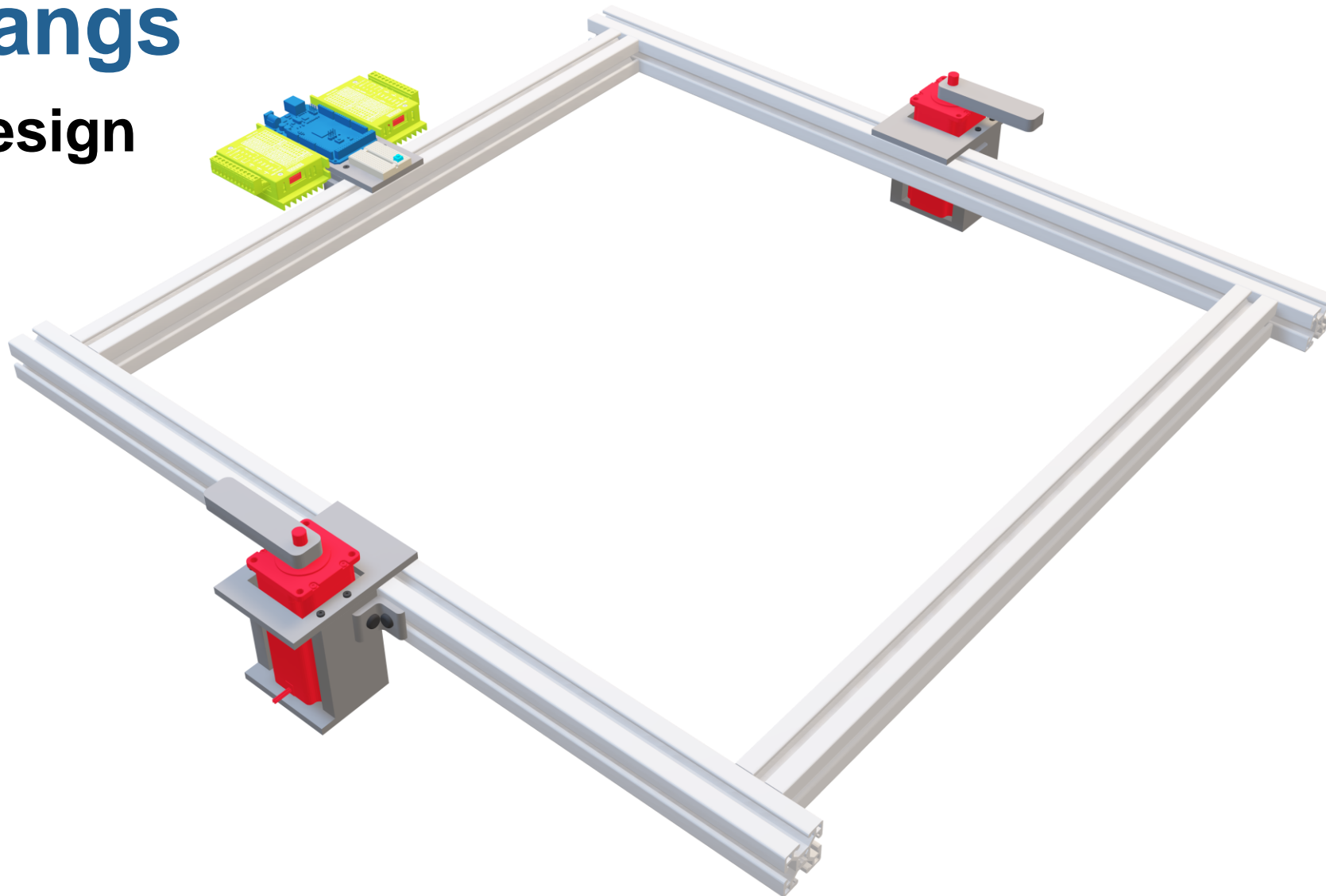

Pawel Grum

Overhangs

Full Design

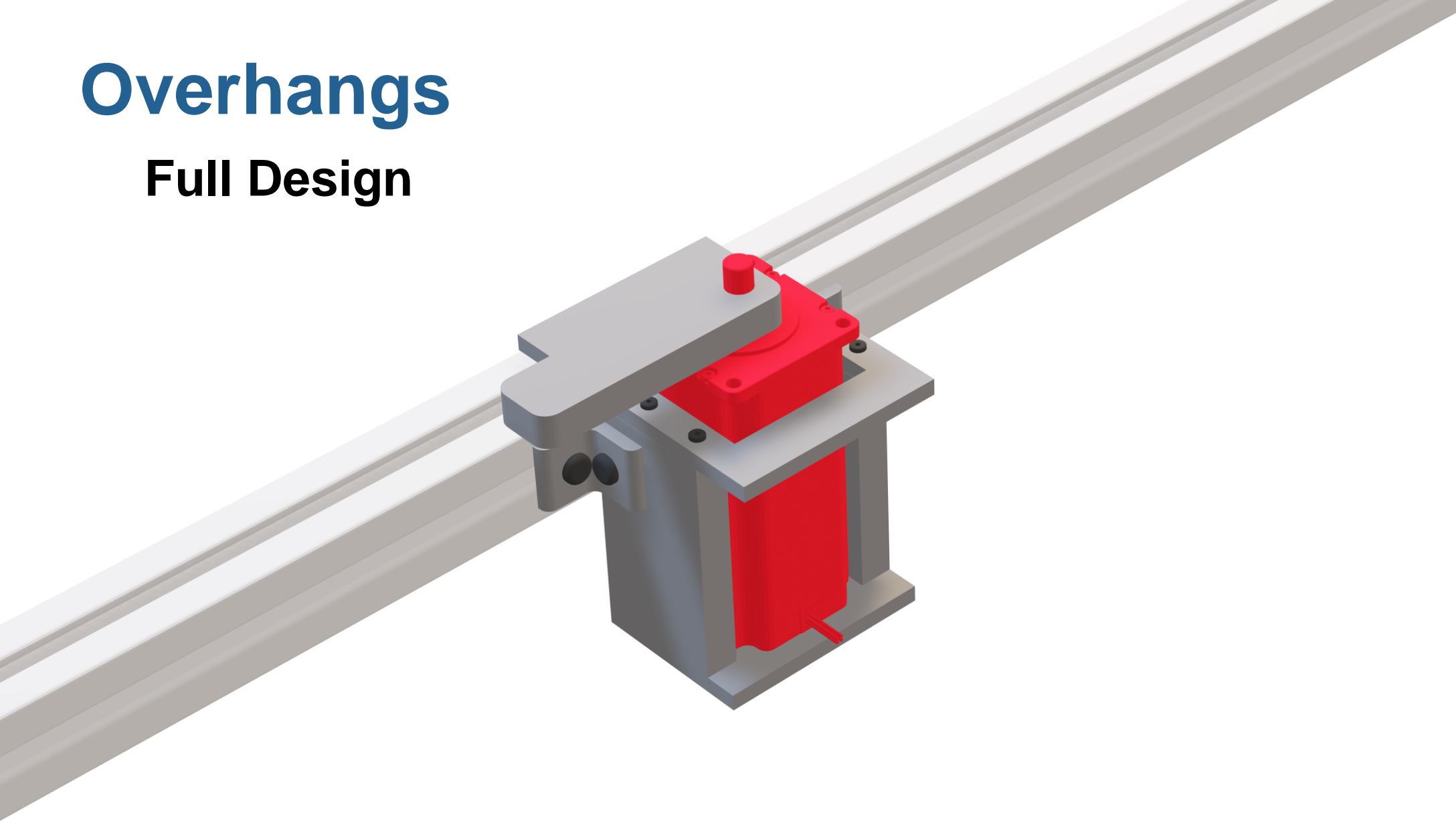

Pawel Grum

Overhangs

Full Design

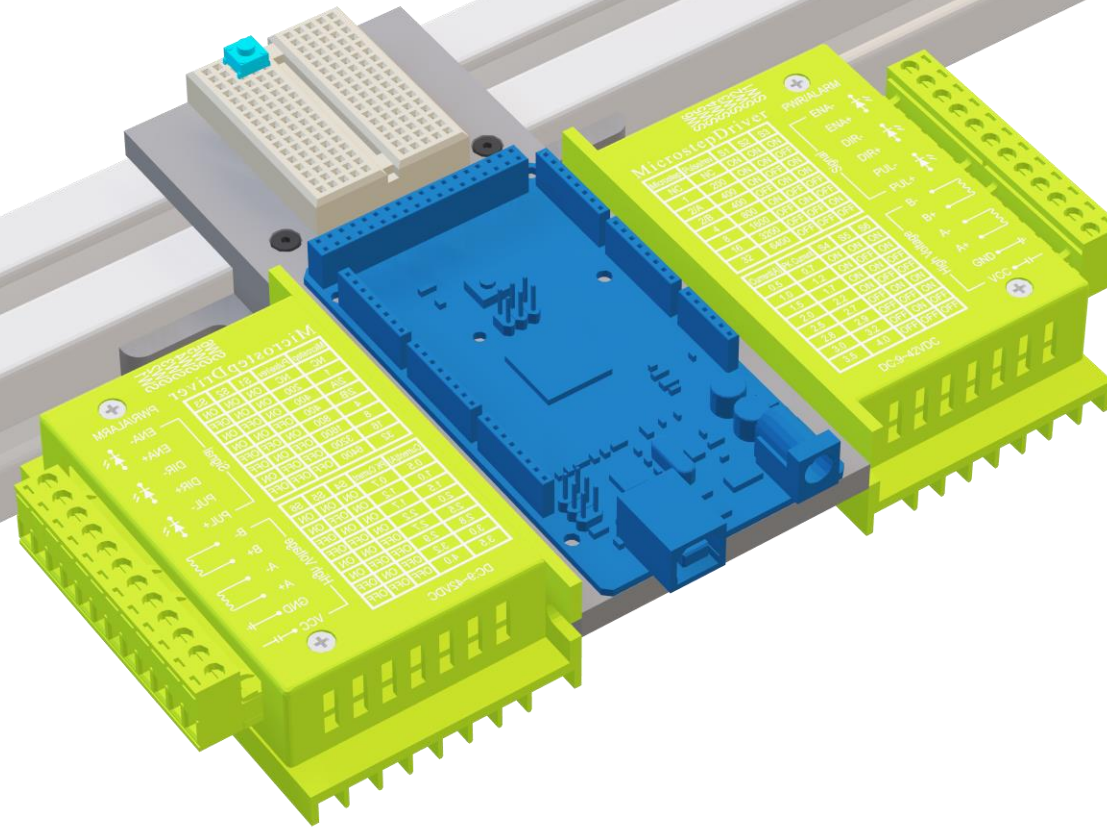

Pawel Grum

Overhangs

Automation Center

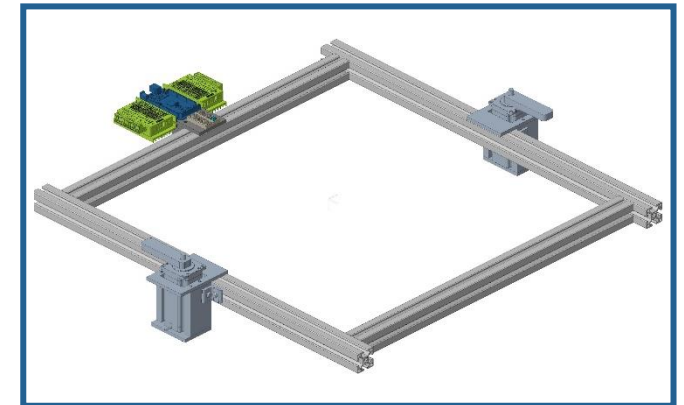
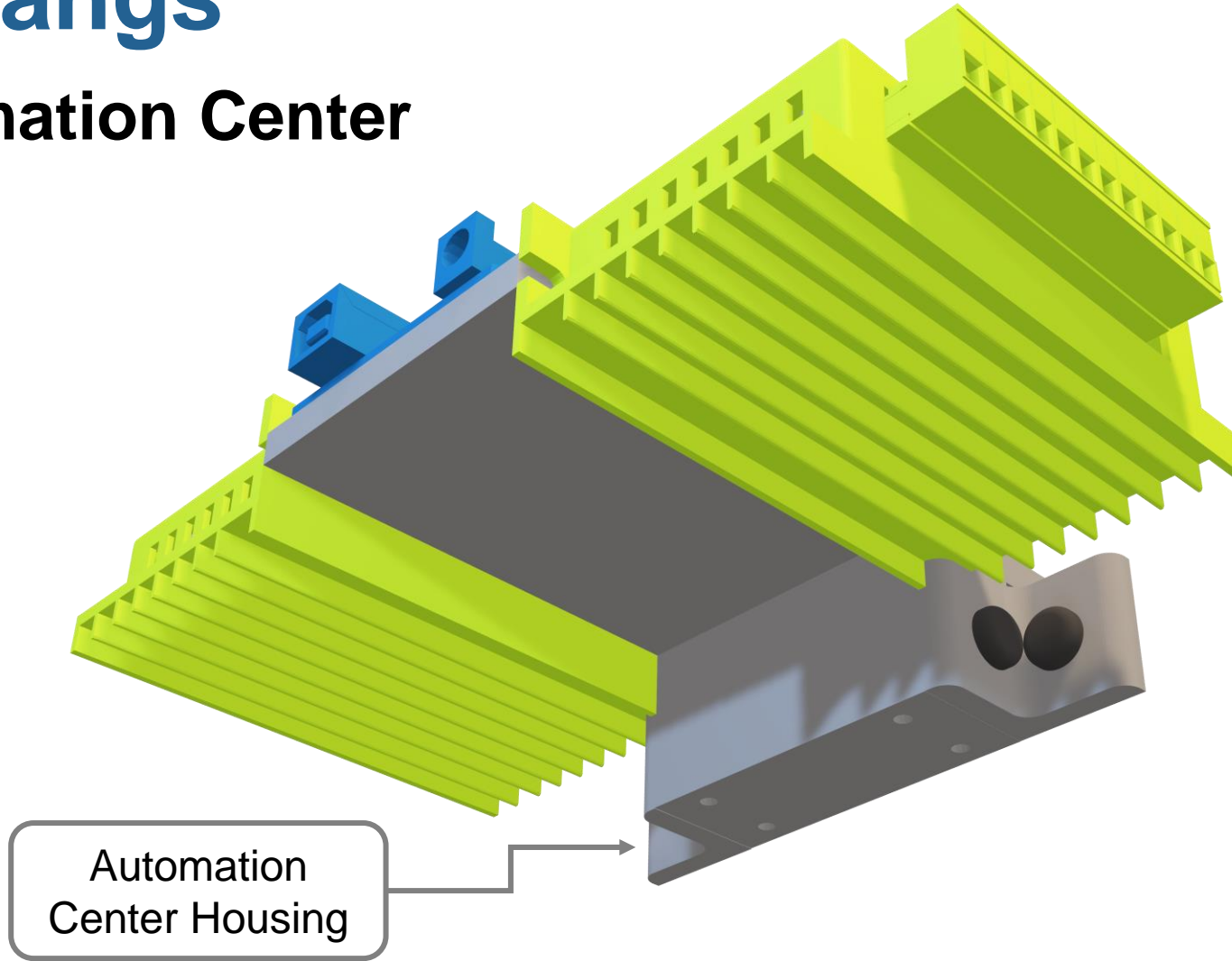

Pawel Grum

Overhangs

Automation Center

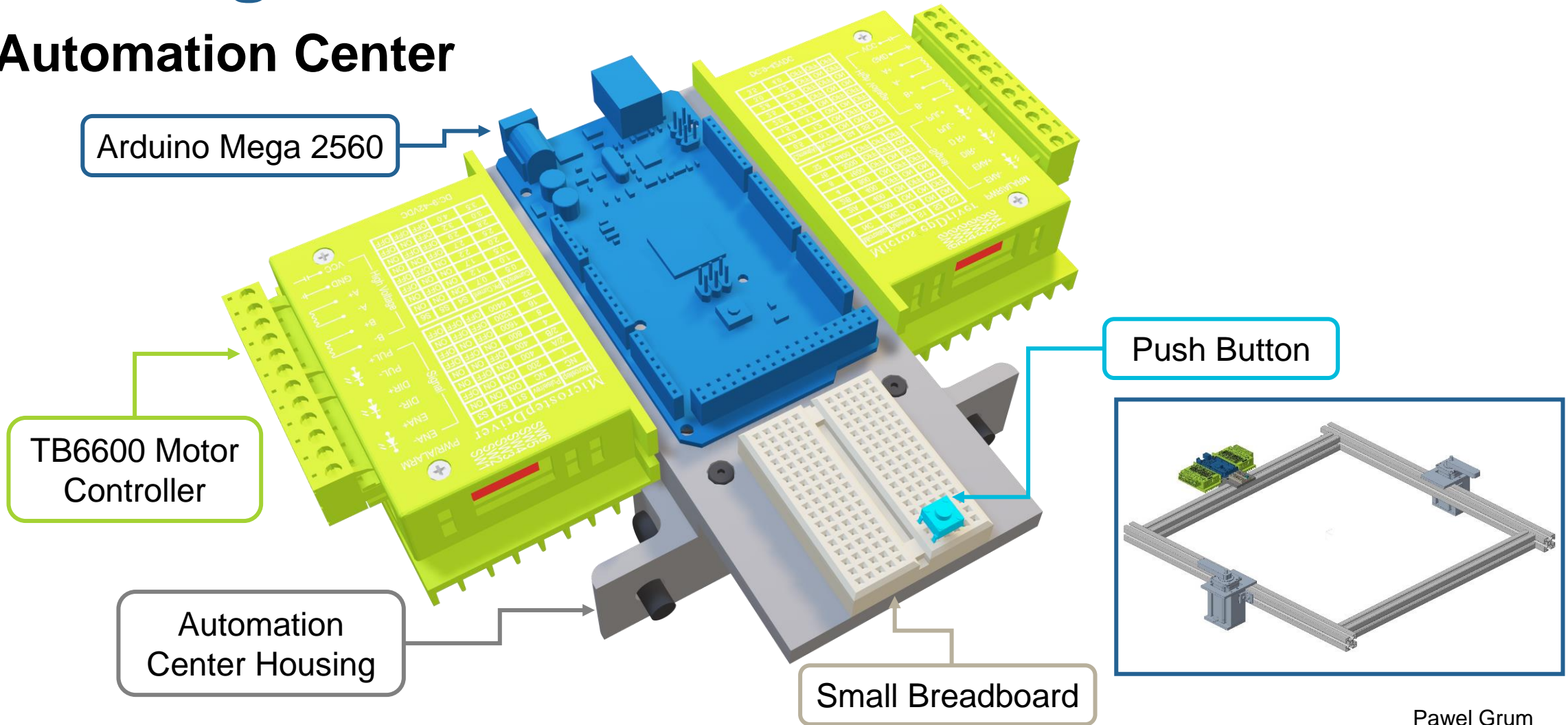

Pawel Grum

Overhangs

Motor Mount

Motor Mount
Housing

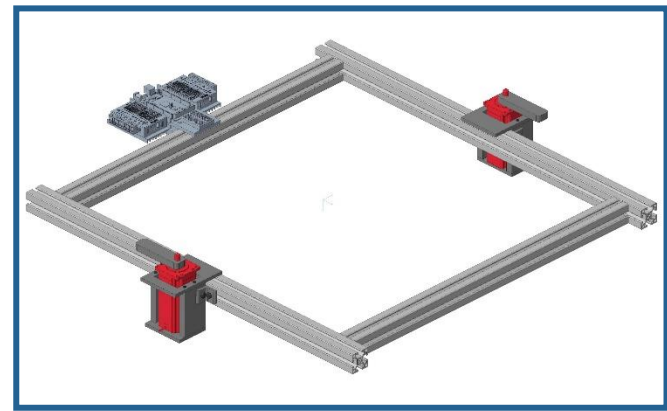
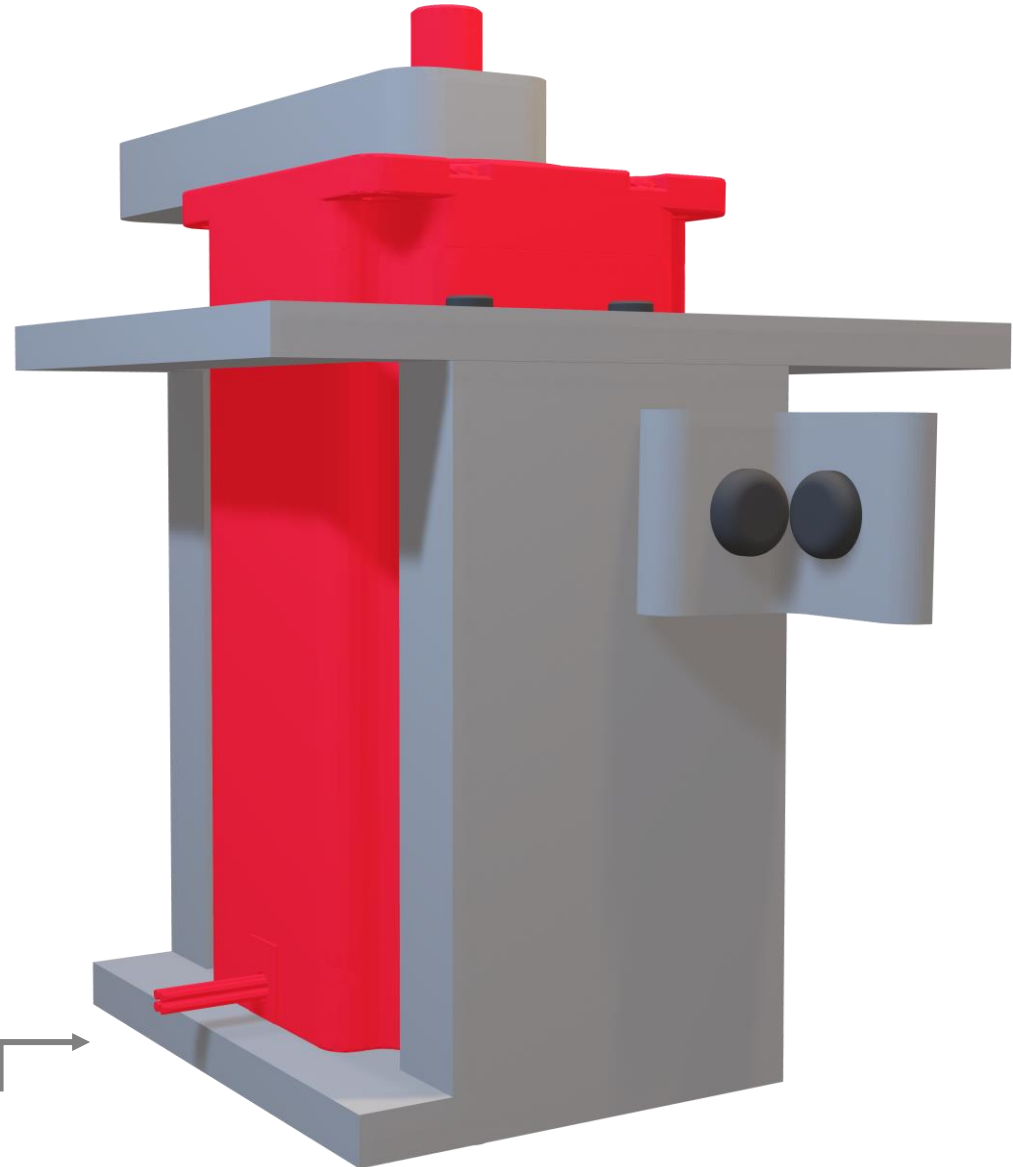

Pawel Grum

Overhangs

Motor Mount

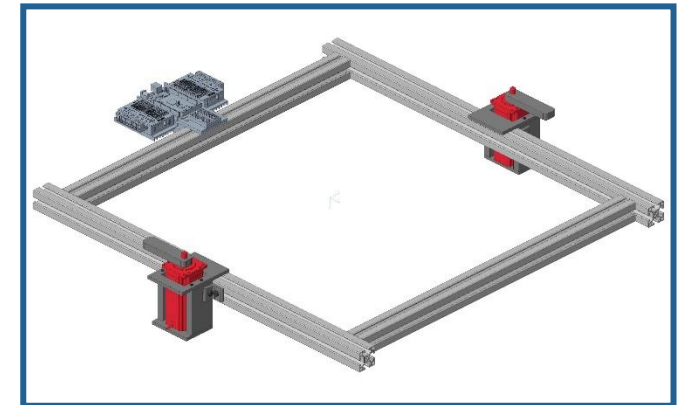
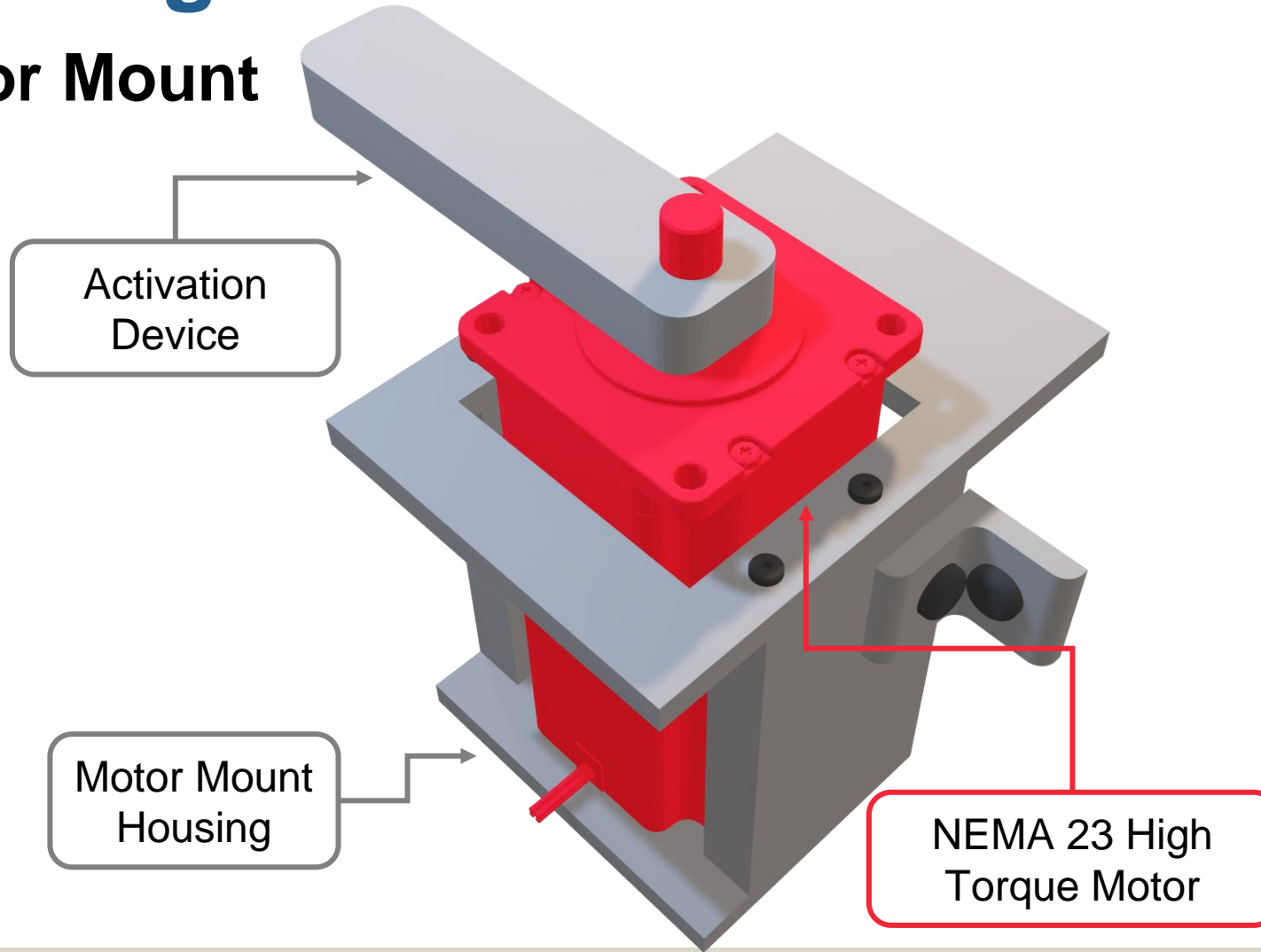

Pawel Grum

Connection Map

Flow Chart for Electronics

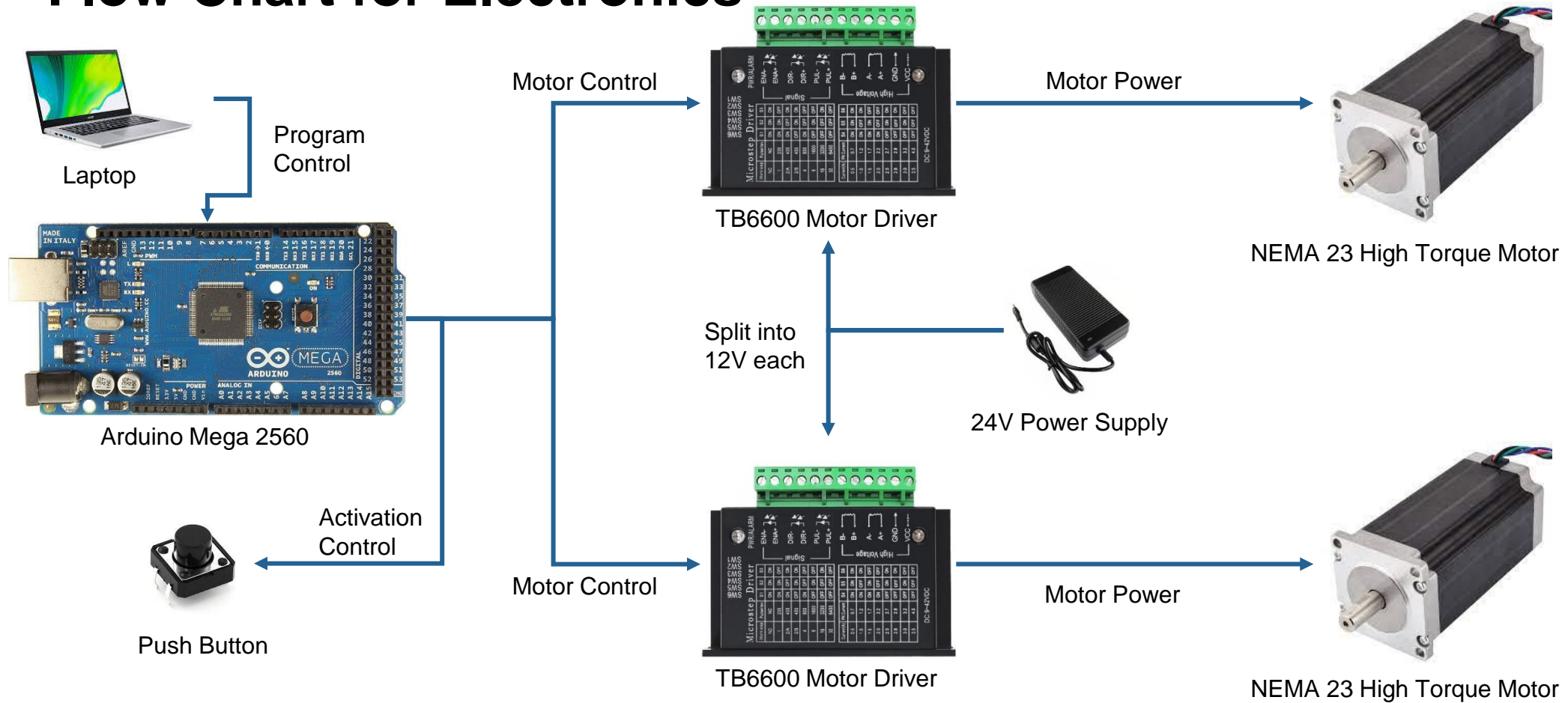

Pawel Grum

Connection Map

Corning RFID Integration

Our System



Corning's System



Integration

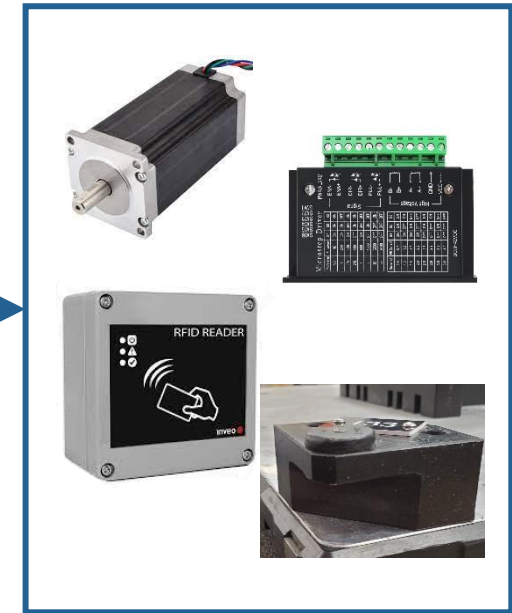

Pawel Grum

Full Design

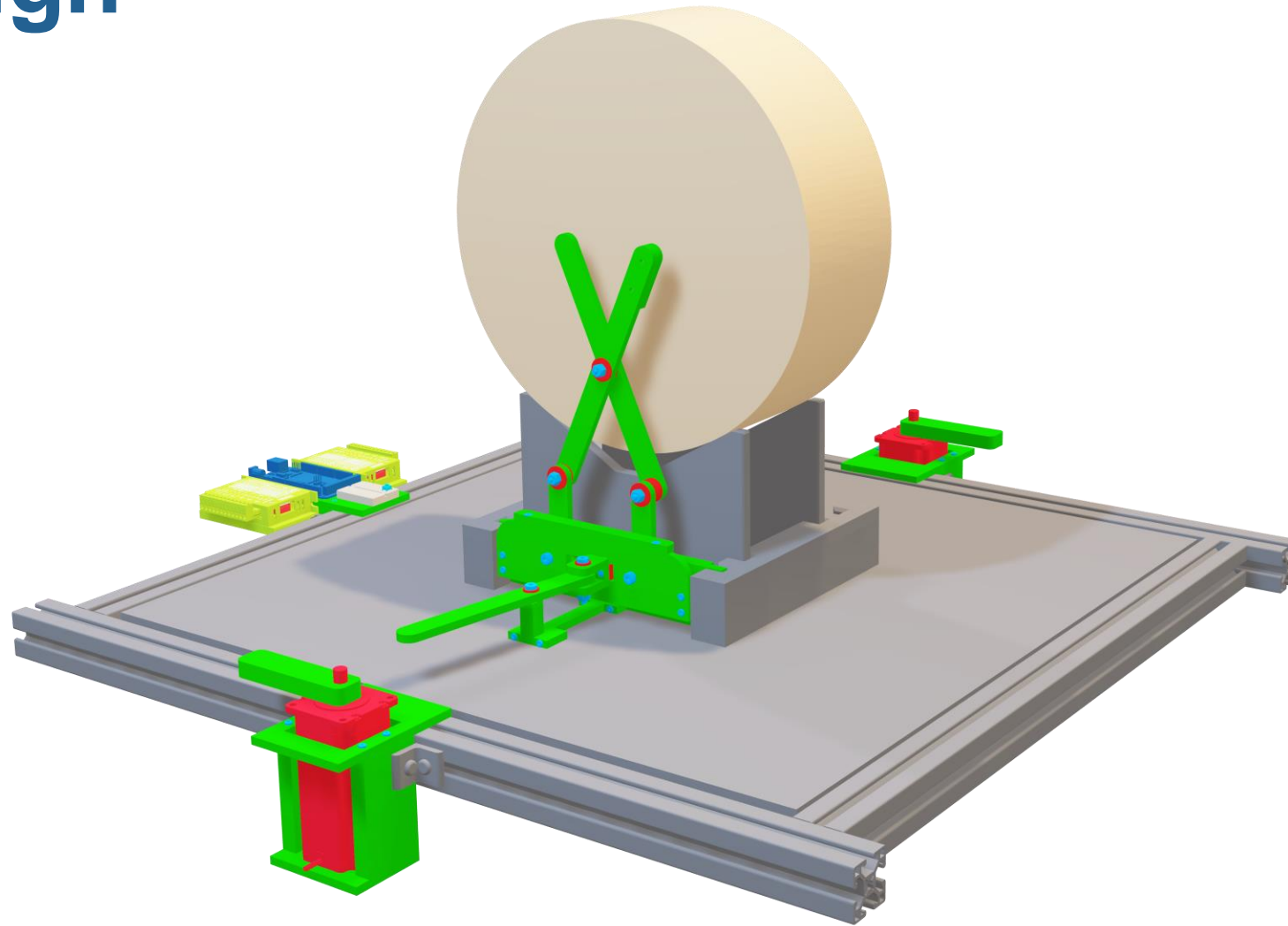

Pawel Grum

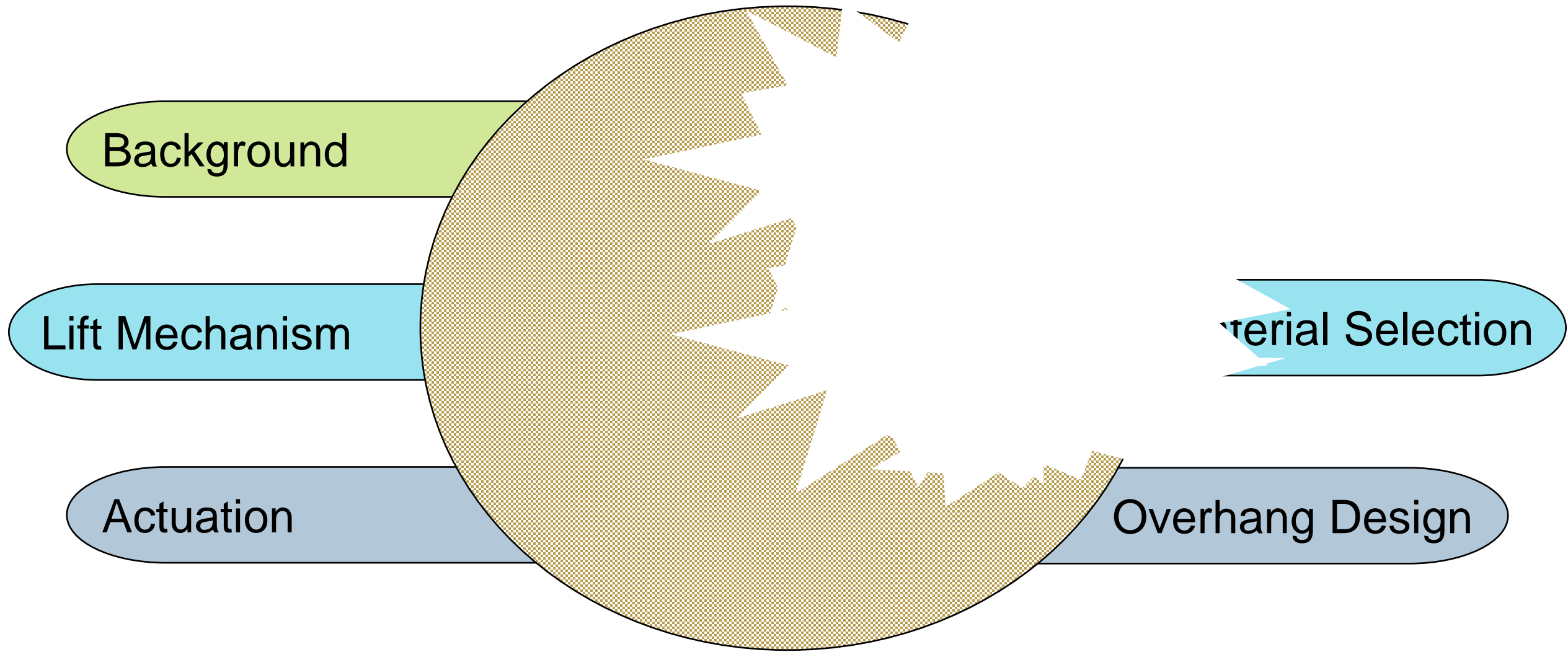

Pawel Grum

Material Selection

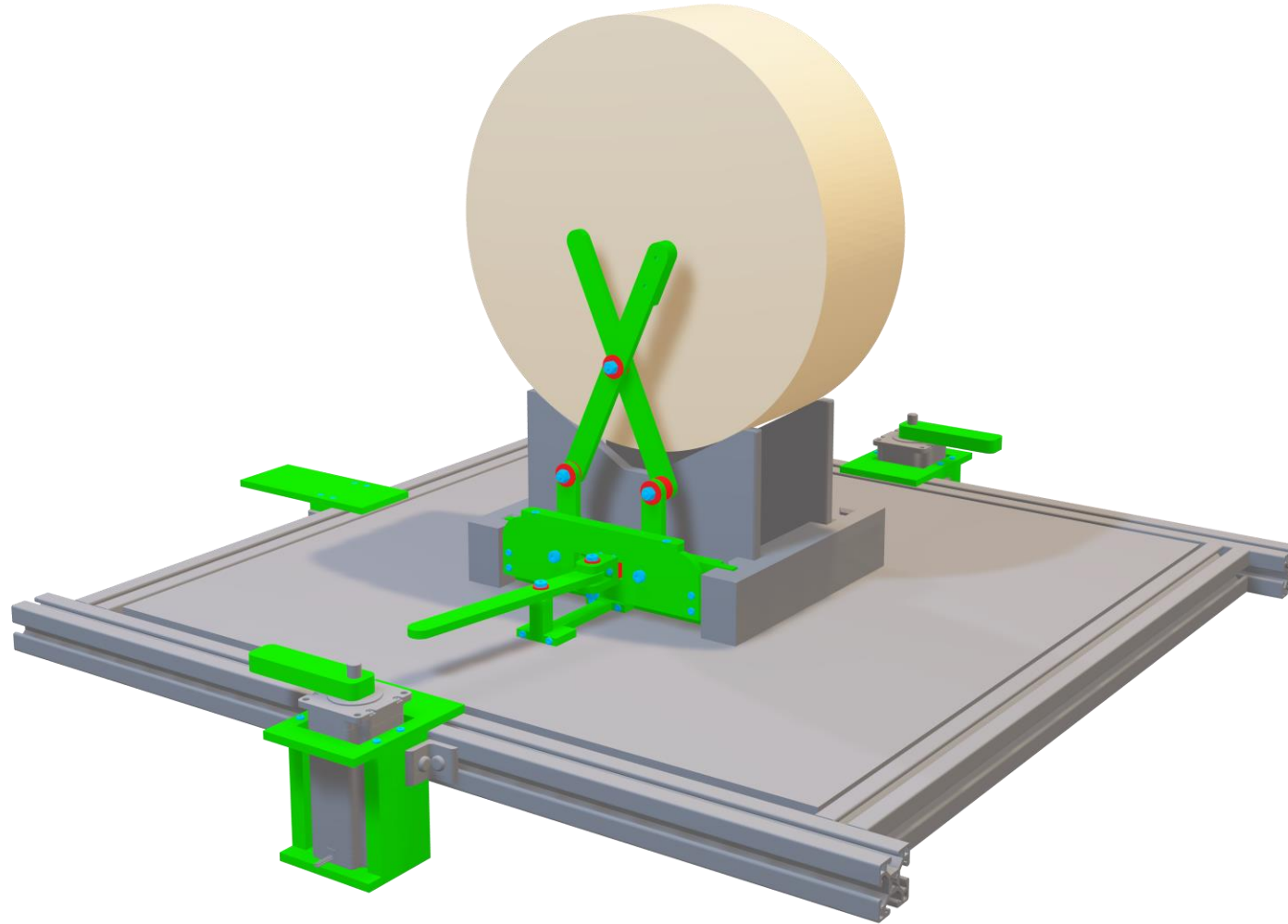

Taylor Larson

Material Selection

Base and Linkages

- Aluminum 6061

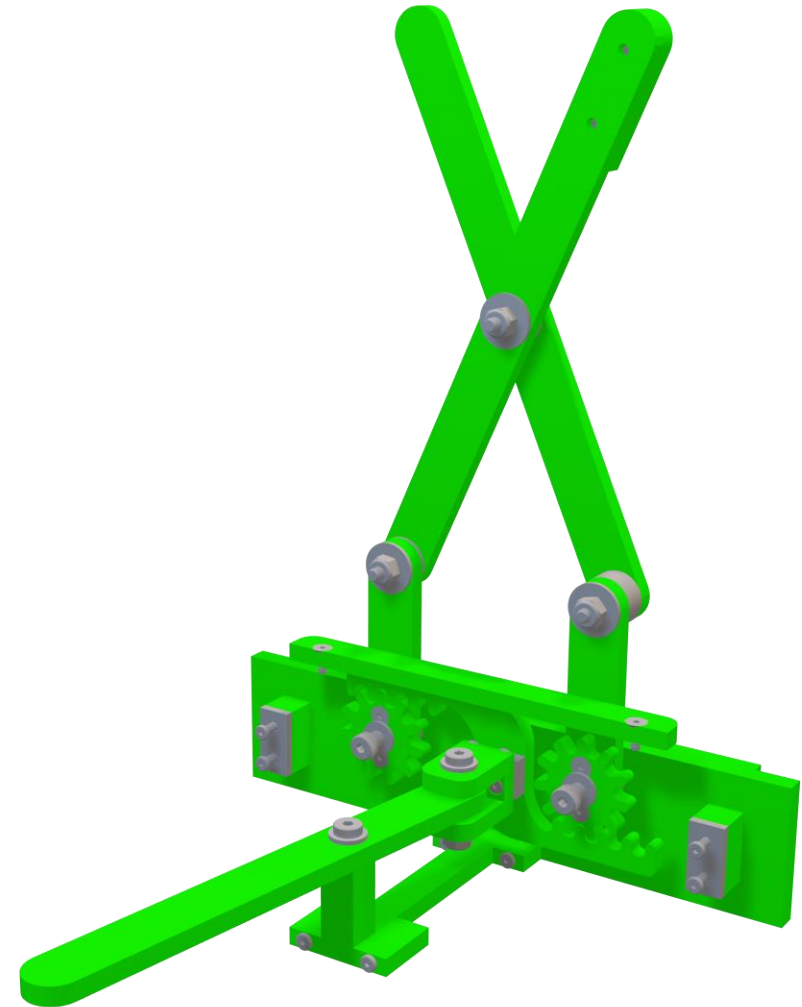
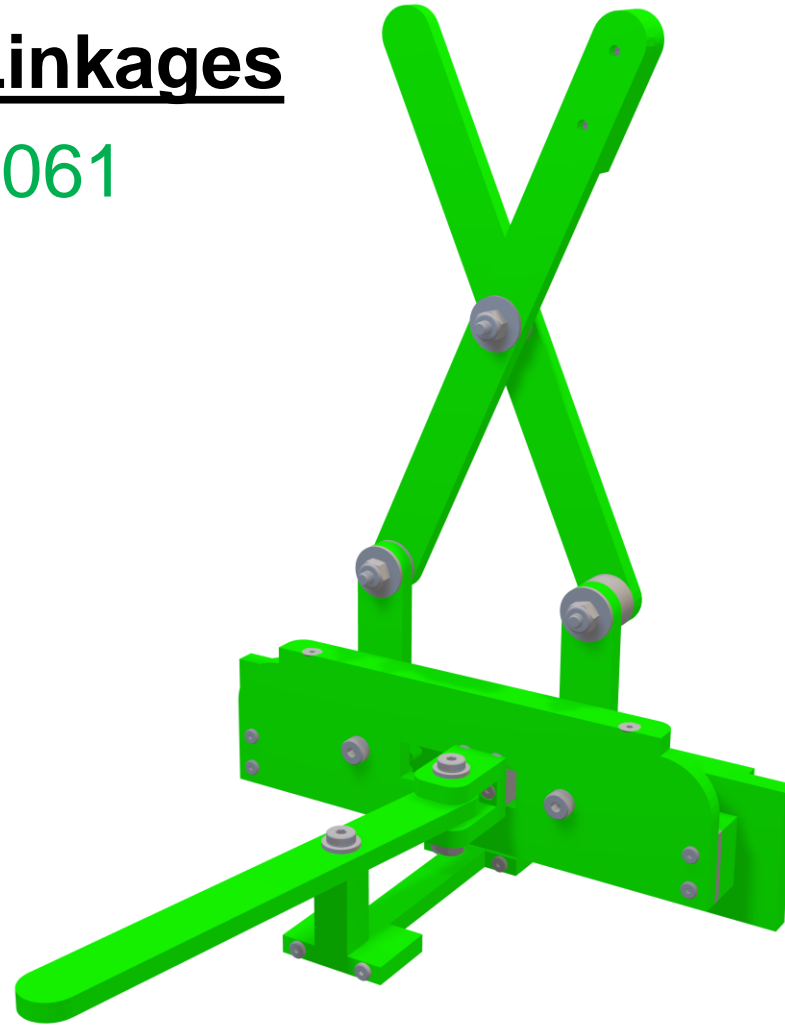

Taylor Larson

Material Selection

Base and Linkages

- Aluminum 6061

Hardware

- Alloy Steel Shoulder Bolts
- Alloy Steel Screws
- Aluminum-Nylon Lock Nuts

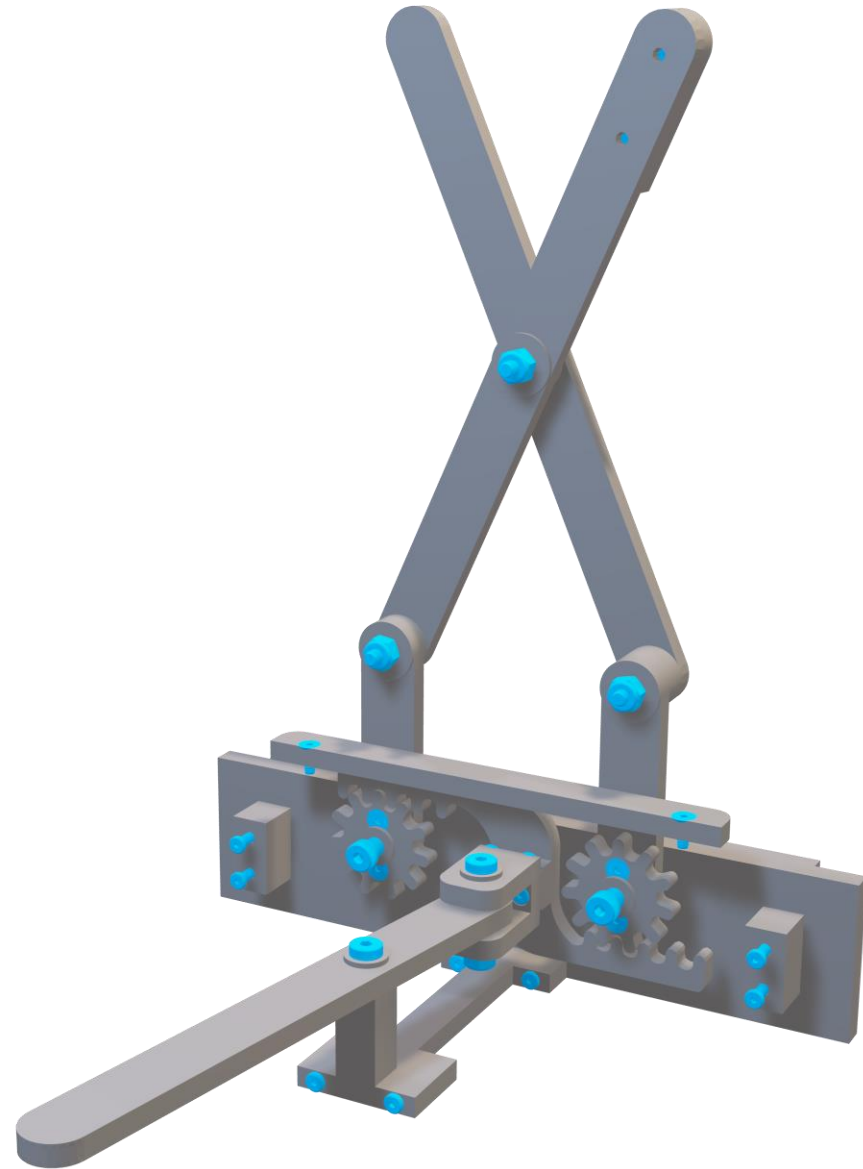

Taylor Larson

Material Selection

Base and Linkages

- Aluminum 6061

Hardware

- Alloy Steel Shoulder Bolts
- Alloy Steel Screws
- Aluminum-Nylon Lock Nuts

Washers and Spacers

- UHMW Polyethylene

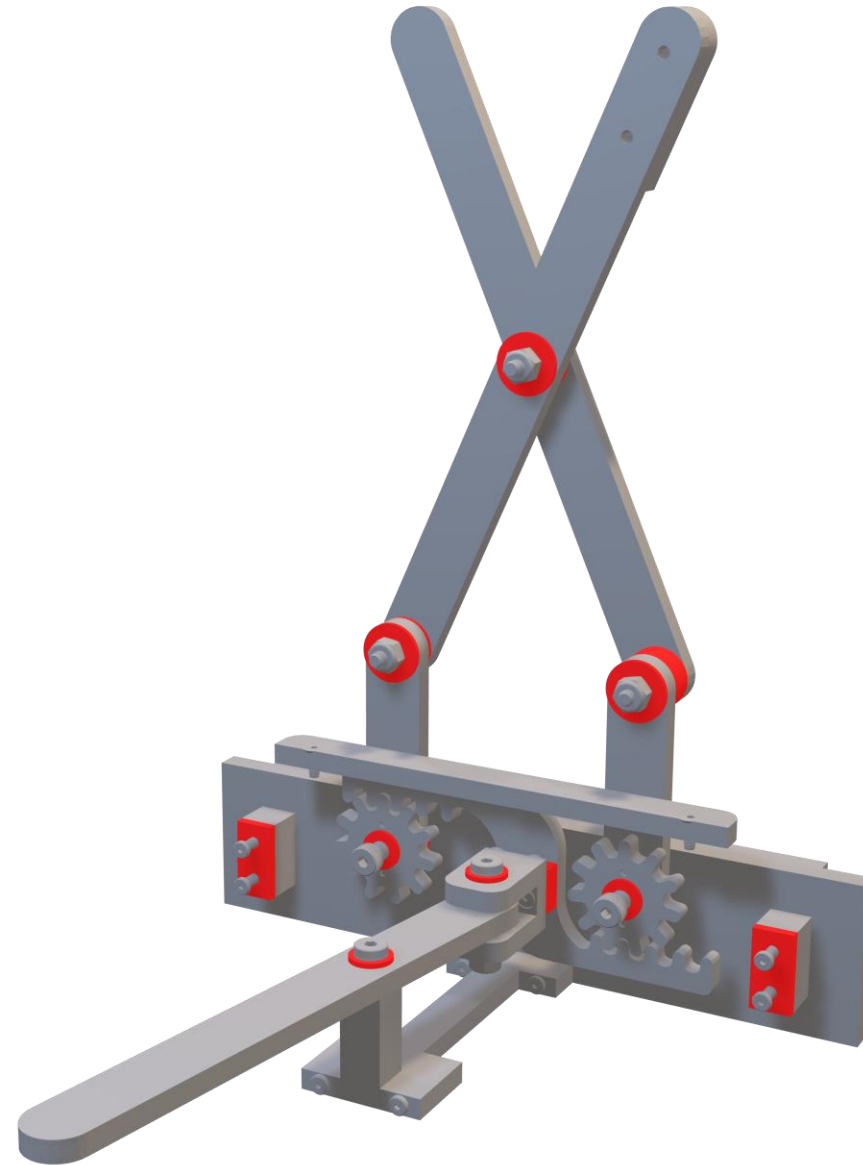

Taylor Larson

Material Selection

Base and Linkages

- Aluminum 6061

Hardware

- Alloy Steel Shoulder Bolts
- Alloy Steel Screws
- Aluminum-Nylon Lock Nuts

Washers and Spacers

- UHMW Polyethylene

Mounts and Slapstick

- Aluminum 6061

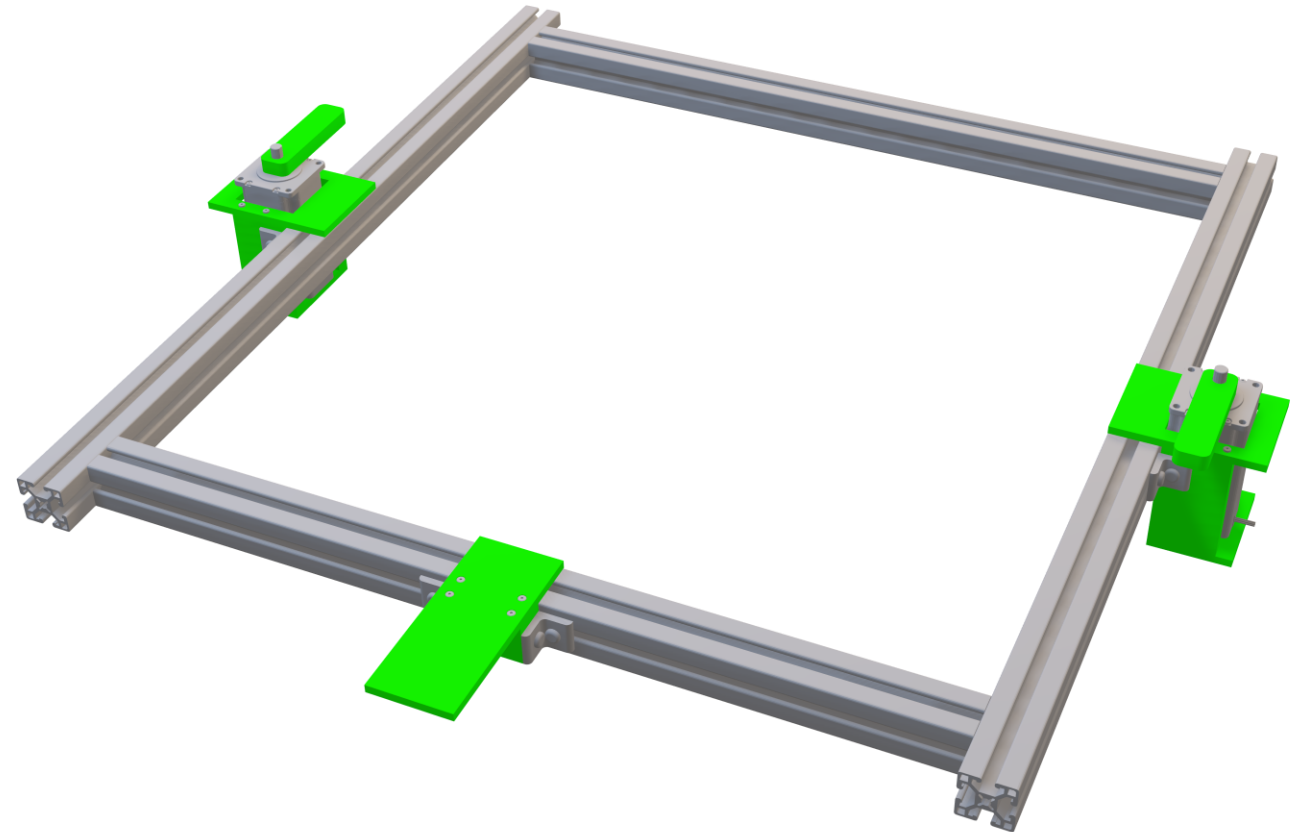

Taylor Larson

Budget Breakdown

Expense Report

Project budget \$2000

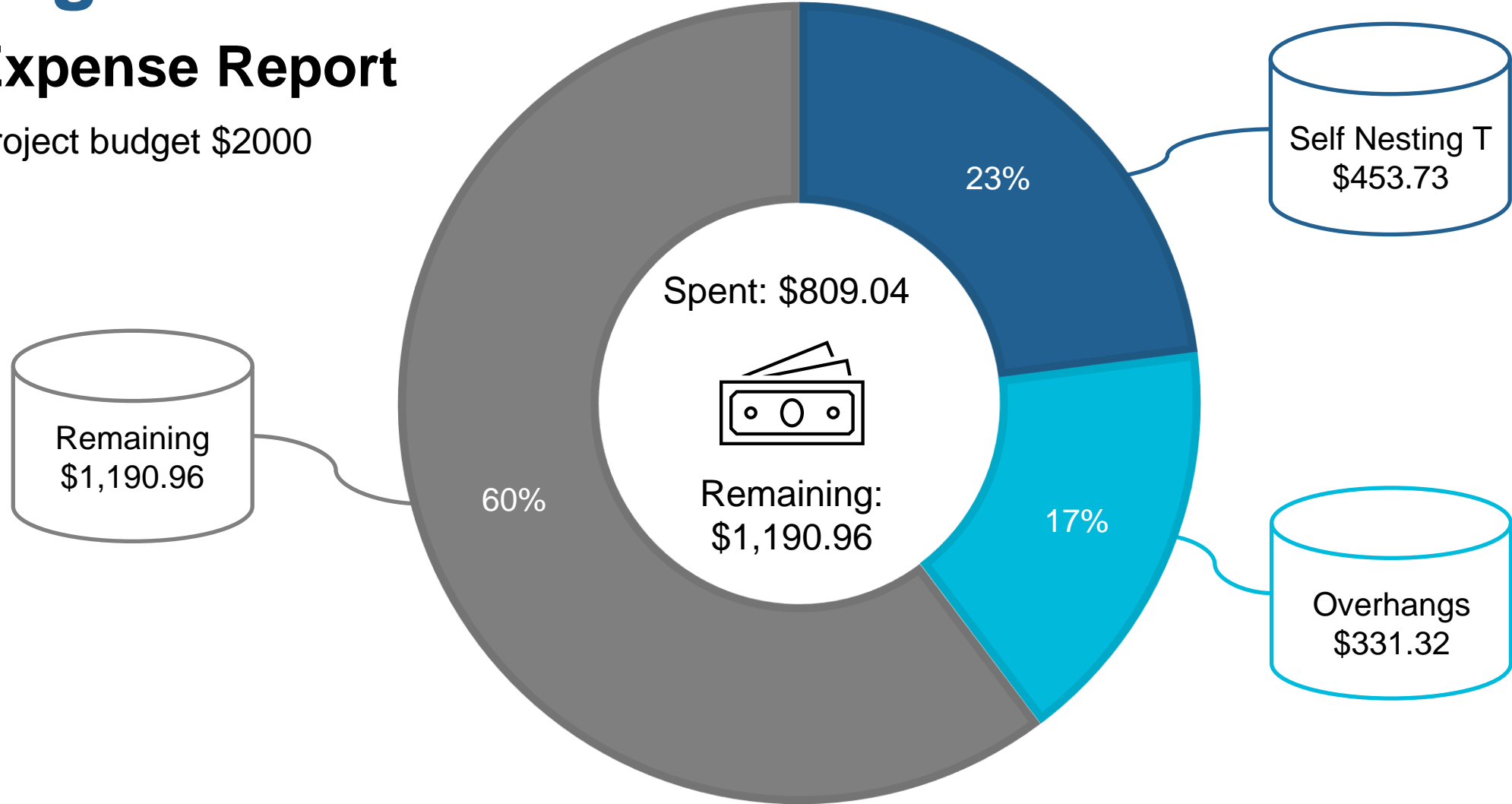

Taylor Larson

Budget Breakdown

Purchasing Details

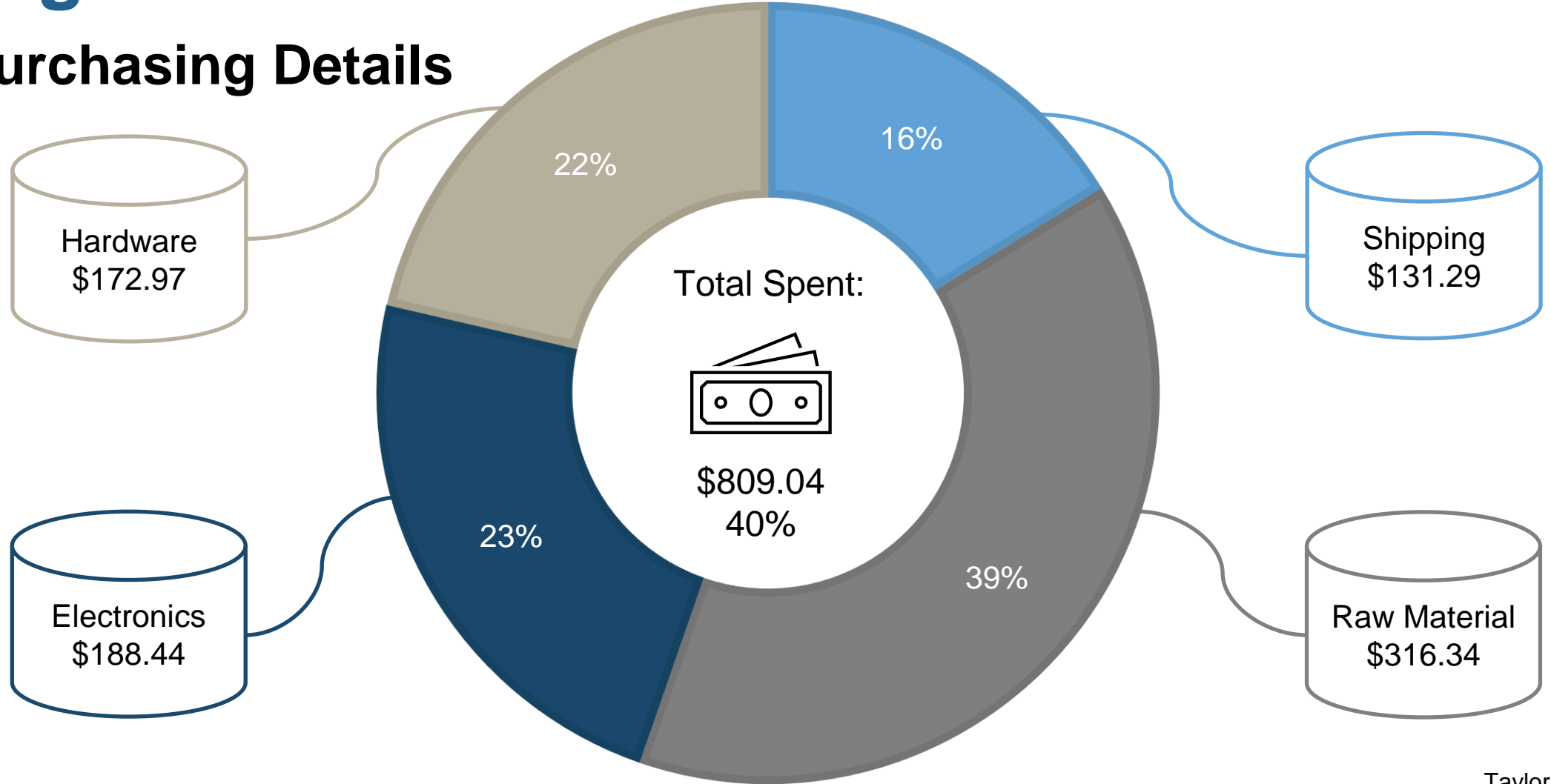

Taylor Larson

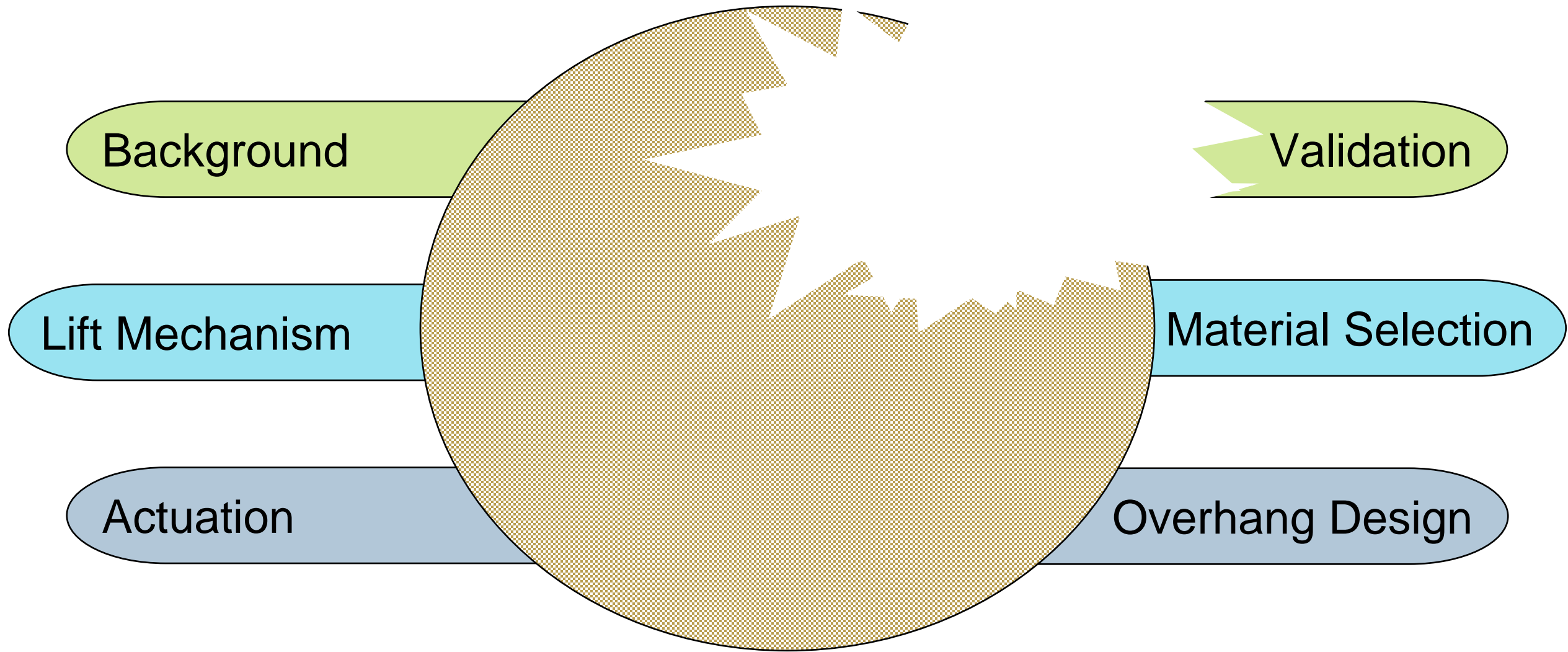

Taylor Larson

Validation

Retraction and Expansion

	Target	Measured
Retraction Height	<6 in	4 in

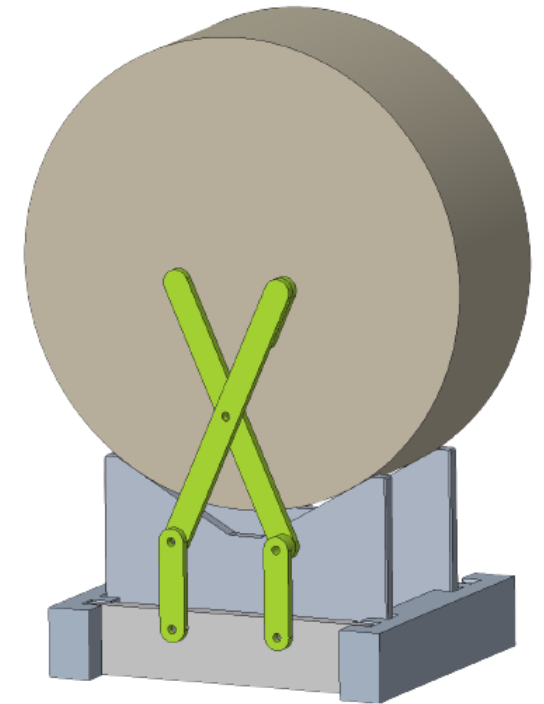
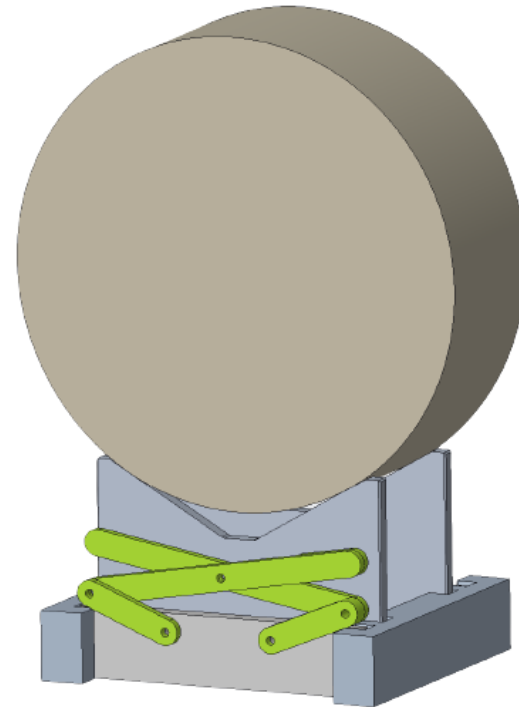

Robert Kosmas

Validation

Actuation Time

Time	Target	Measured
	48 sec	<5 sec

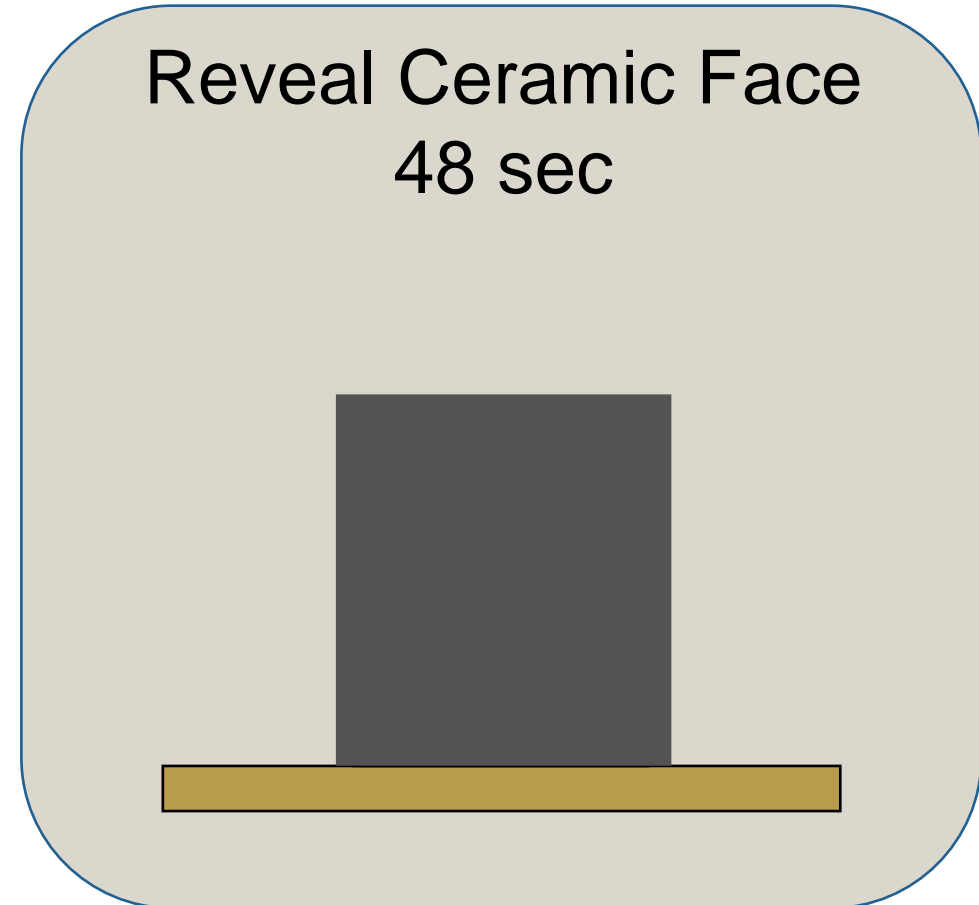

Robert Kosmas

Validation

Load

	Target	Measured
Load	8 lbs	10 lbs

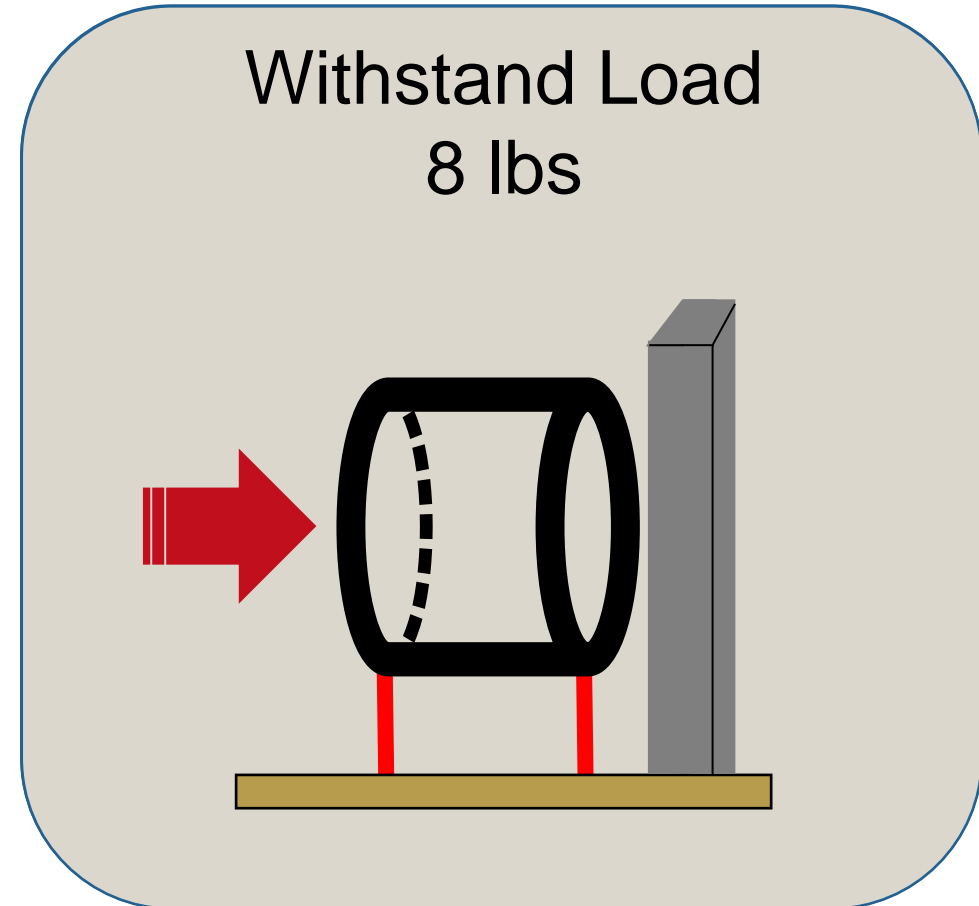

Robert Kosmas

Validation

Currently Validating

Prevent Damage
0%

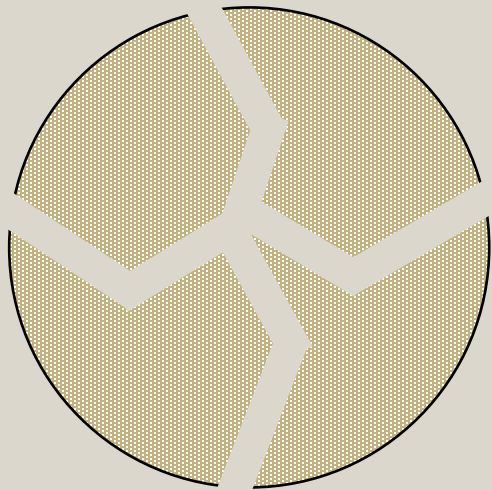

Particle
Resistance

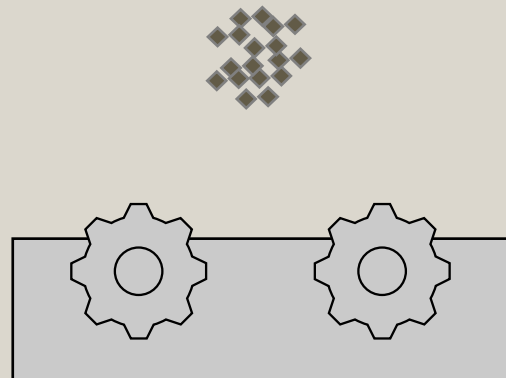

Limit Manual
Labor

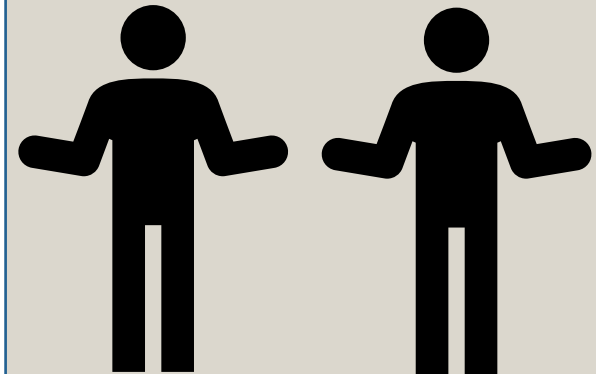

Robert Kosmas

Improvements

Re-design the engagement method from the conveyor to the device

Select better hardware, and use bolts with matching hex size

Further evaluate the cycle life and resistance of the UHMW

Robert Kosmas

Lessons Learned

Criticism often means
you are off to a good
start.

Don't reinvent the
wheel. Keep it simple.

It's okay if the
prototype is not perfect
the first time. That's
why it's called a
“prototype”.

Robert Kosmas

Summary

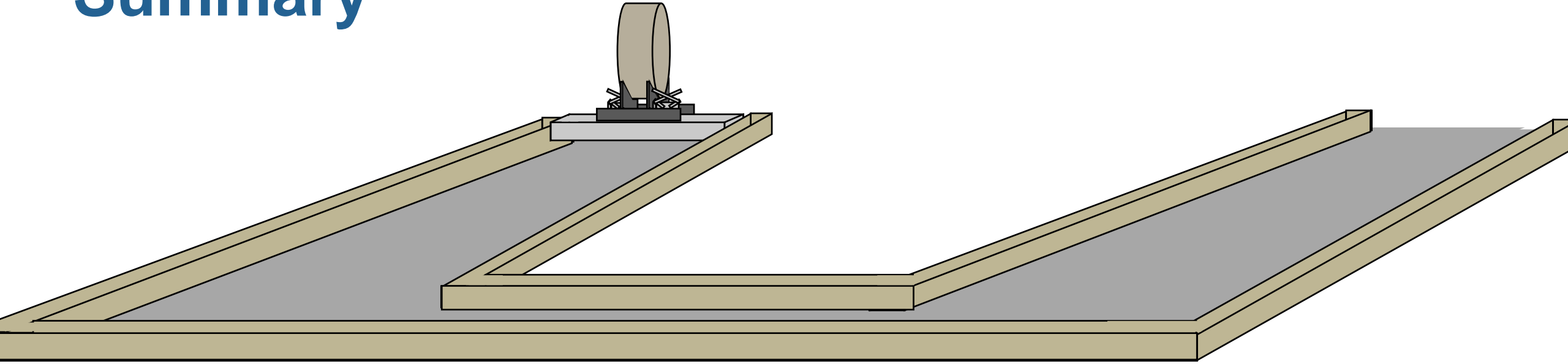

Robert Kosmas

Summary

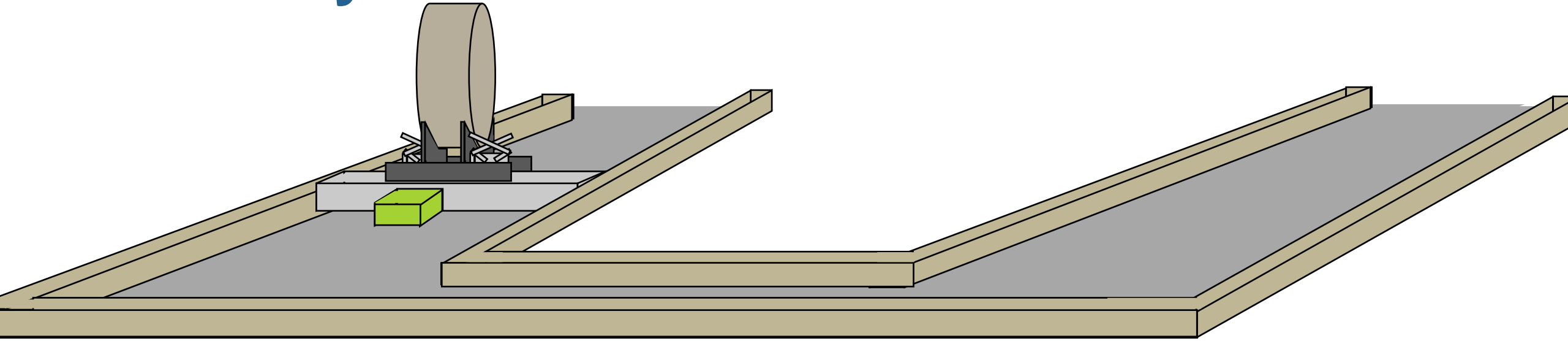

The Self-Nesting T was designed to protect ceramics traveling along a conveyor line, while also limiting the required interactions from plant employees.

Robert Kosmas

Summary

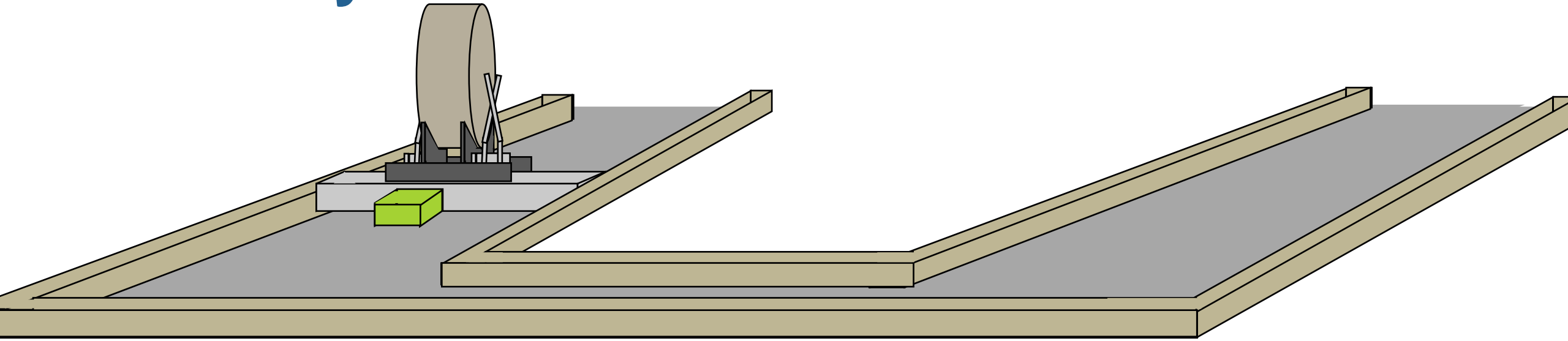

The Self-Nesting T was designed to protect ceramics traveling along a conveyor line, while also limiting the required interactions from plant employees.

Robert Kosmas

Summary

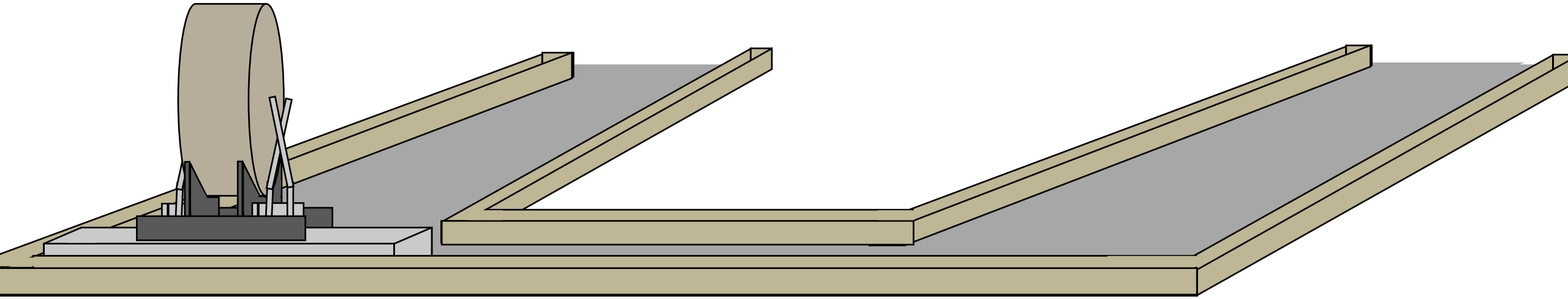

Multiple concepts were generated but the Self-Nesting T was the final selection. It was also highly favored due to it being modeled after the T design that's proven to minimize damage.

Robert Kosmas

Summary

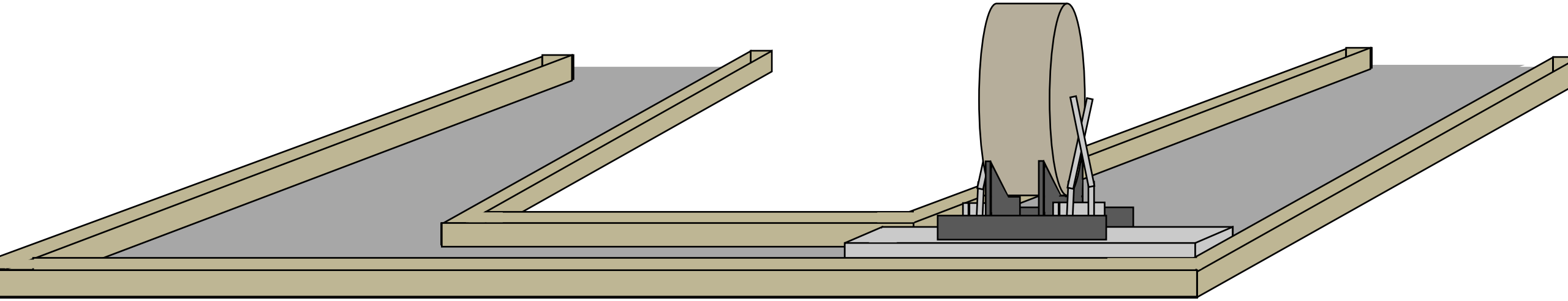

The design is currently being validated, but the team is positive that this design will be able to accomplish our targets and goals validating the overall success of the project.

Robert Kosmas

Summary

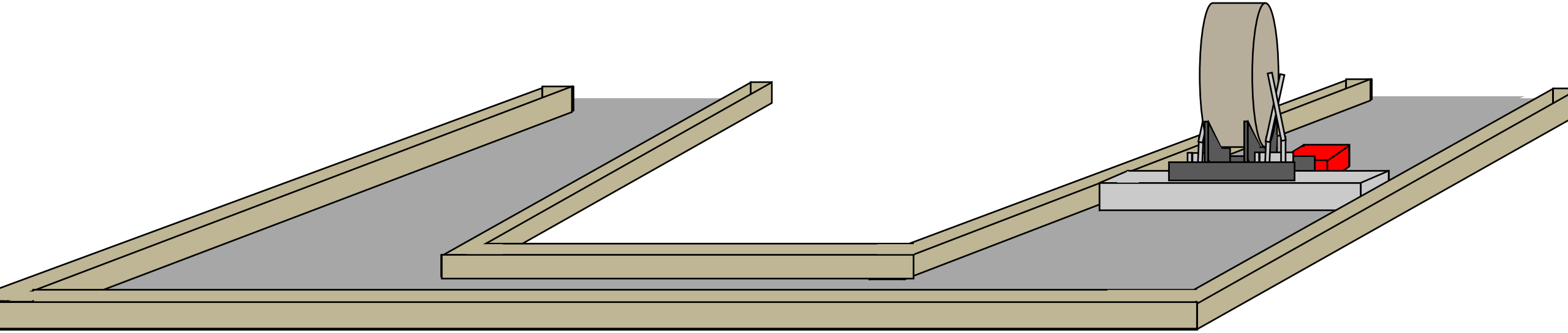

Corning will be able to implement our design into the current manufacturing plant system. Allowing for their ceramics to be protected, while also reducing the required manual labor by being actuated mechanically.

Robert Kosmas

Summary

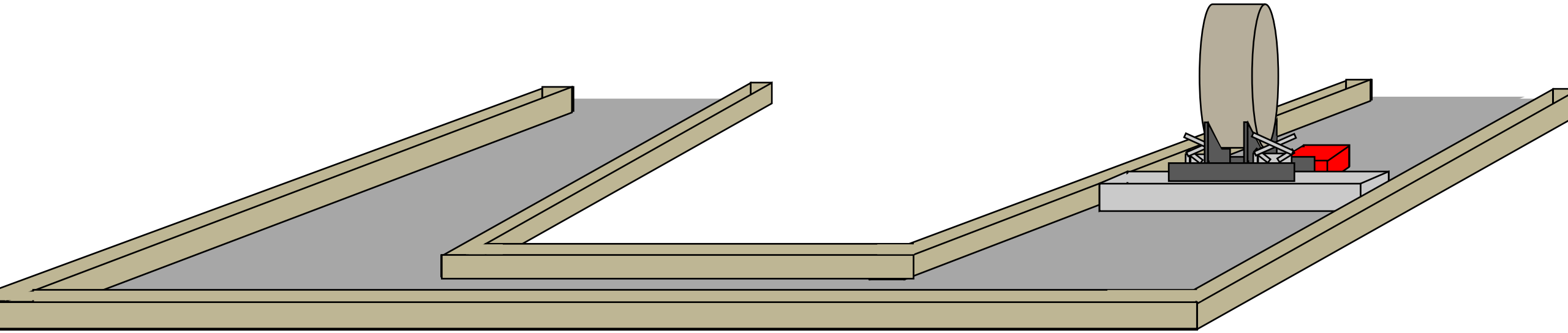

Corning will be able to implement our design into the current manufacturing plant system. Allowing for their ceramics to be protected, while also reducing the required manual labor by being actuated mechanically.

Robert Kosmas

Summary

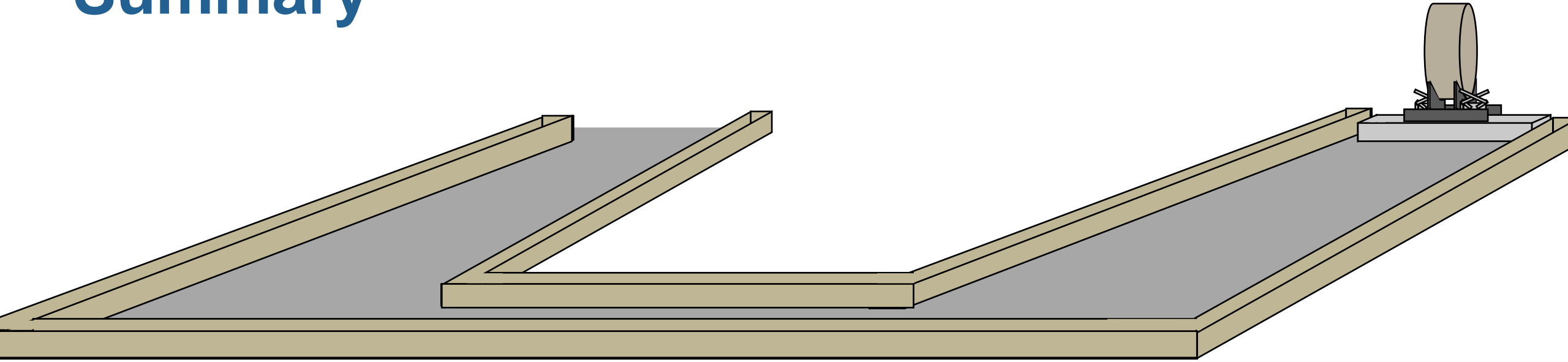

Corning will be able to implement our design into the current manufacturing plant system. Allowing for their ceramics to be protected, while also reducing the required manual labor by being actuated mechanically.

Robert Kosmas

Thank you!

Pawel J. Grum | Robert C. Kosmas | Taylor M. Larson | Segundo A. Sanchez | Jared T. White

pjg17@fsu.edu

rck19a@fsu.edu

tml18bg@fsu.edu

sas19x@fsu.edu

jtw18c@fsu.edu

