

Team 506: Corning Plugger Pallet Short Part Stabilization

Pawel J. Grum | Robert C. Kosmas | Taylor M. Larson | Segundo A. Sanchez | Jared T. White

Team Members



Pawel J.
Grum

*Mechanical Test
Engineer*



Robert C.
Kosmas

*Structural Design
Engineer*



Taylor M.
Larson

*Dynamics
Engineer*



Segundo A.
Sanchez

*Materials Analysis
Engineer*



Jared T.
White

*Manufacturing
Engineer*

Taylor Larson



Sponsors and Advisors

Jeffery Roche



Engineering Mentor

*Heavy Duty Project
Manager*

Jeffery Stott



Engineering Mentor

*Equipment Engineering
Manager*

Eric Hellstrom, Ph.D



Academic Advisor

*Materials Science
Program Director*

Taylor Larson



Project Objective

The objective of this project is to produce a stabilization system to protect ceramics on Corning's conveyor while reducing the required manual labor.

Taylor Larson

Project Background

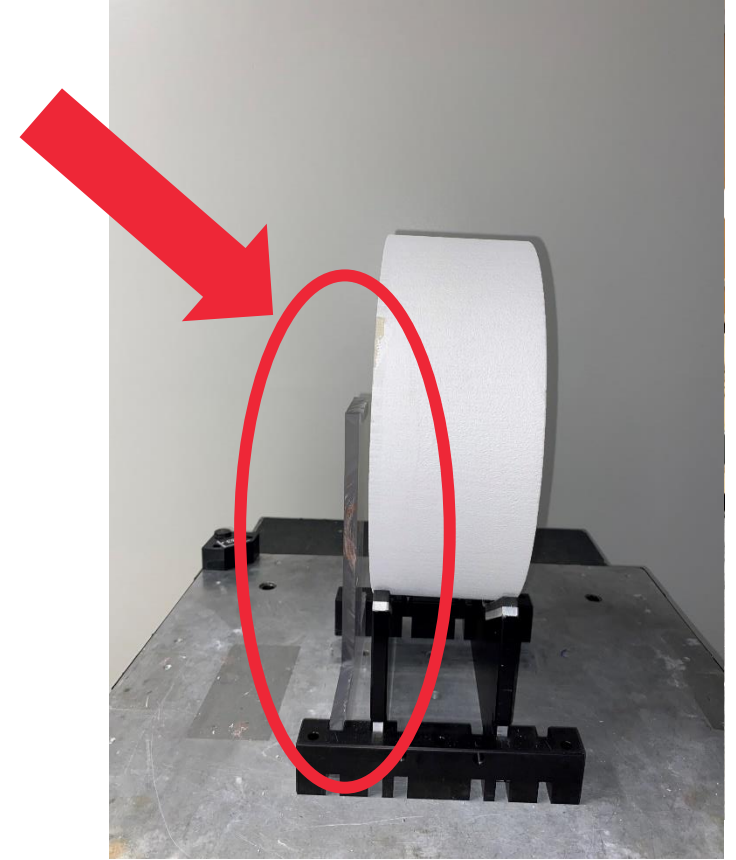
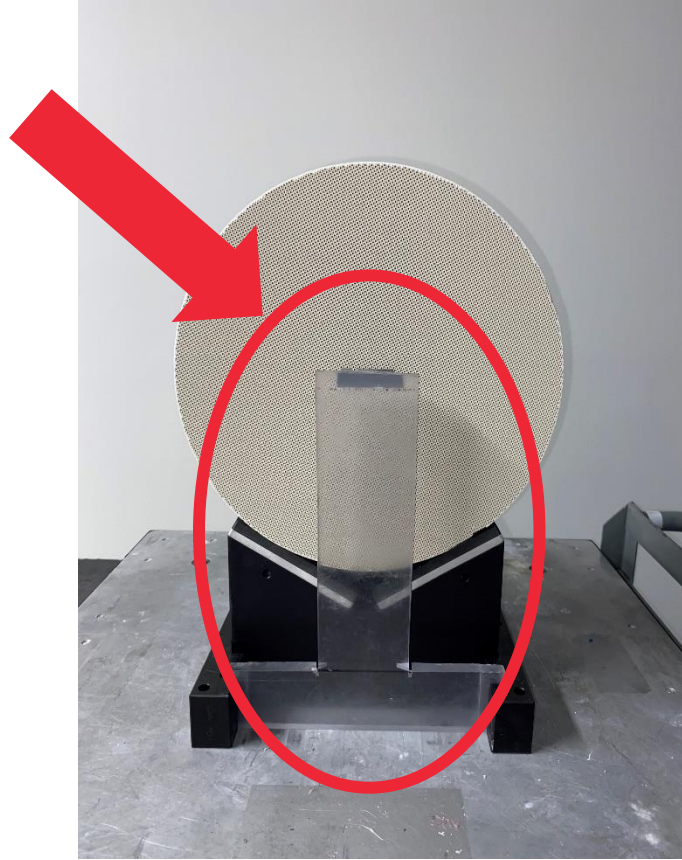

Taylor Larson

Key Goals

Taylor Larson



Key Goals

Prevent Damage



Limit Interaction

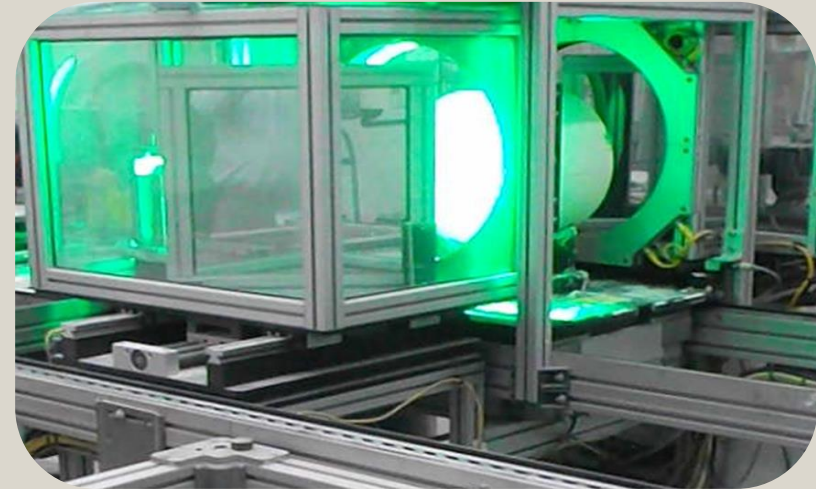

Taylor Larson

Key Goals

Integrate with conveyor system

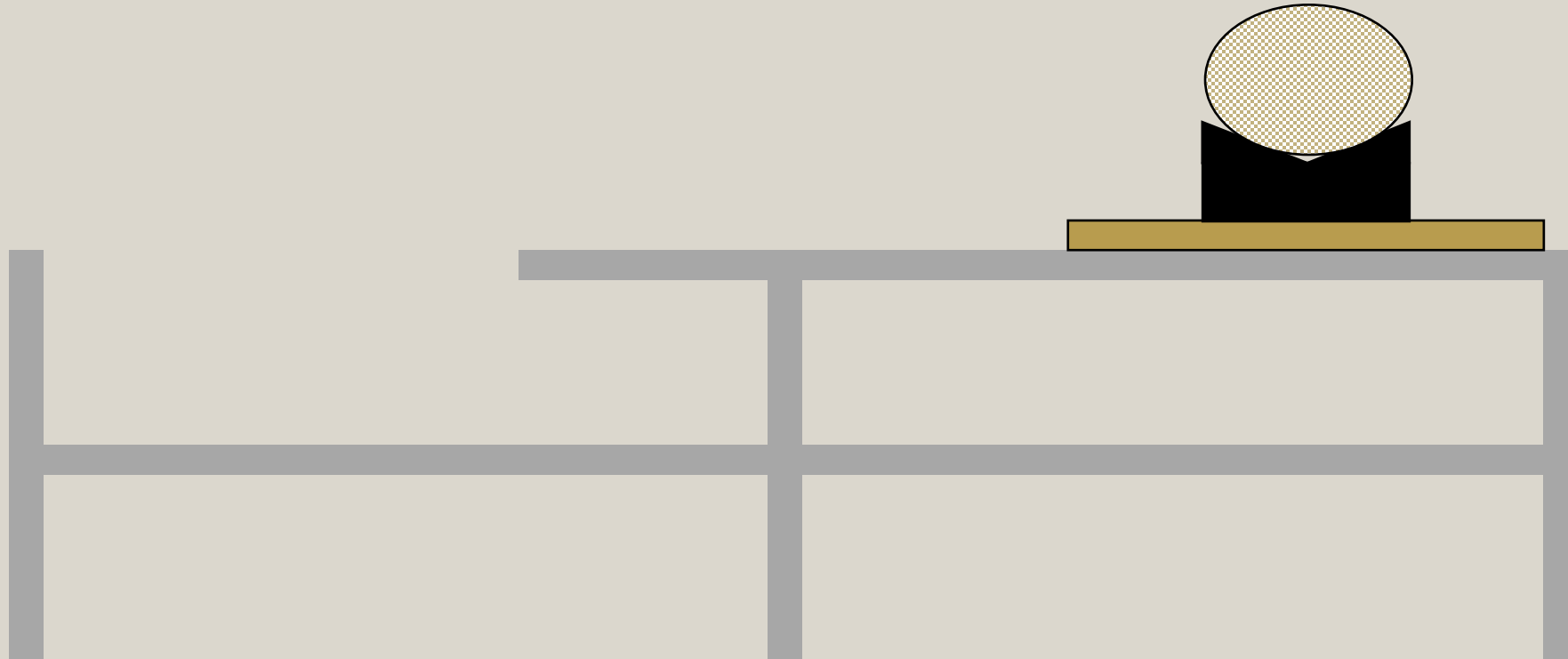

Taylor Larson

Key Goals

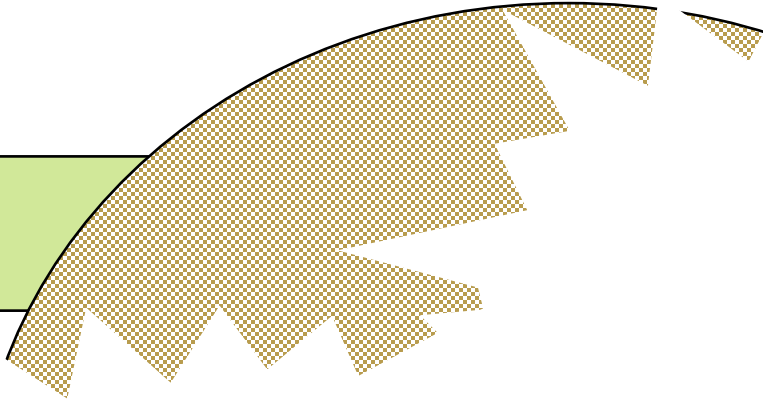

Critical Targets

Taylor Larson

Critical Targets

Secure Ceramic
1 DOF

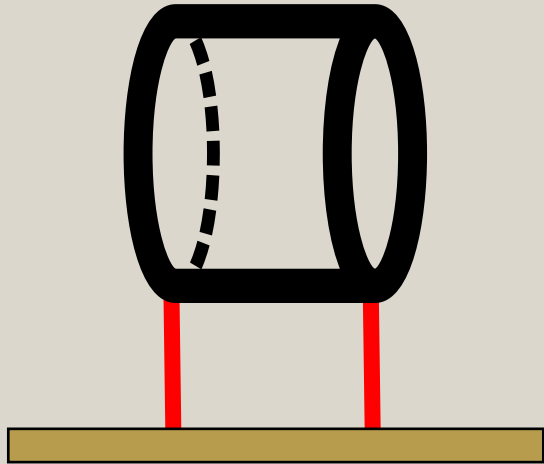

Prevent Damage
0%

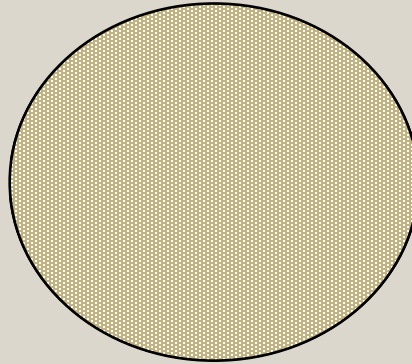

Limit Manual
Labor
1 Person



Taylor Larson

Critical Targets

Withstand Load
8 lbs

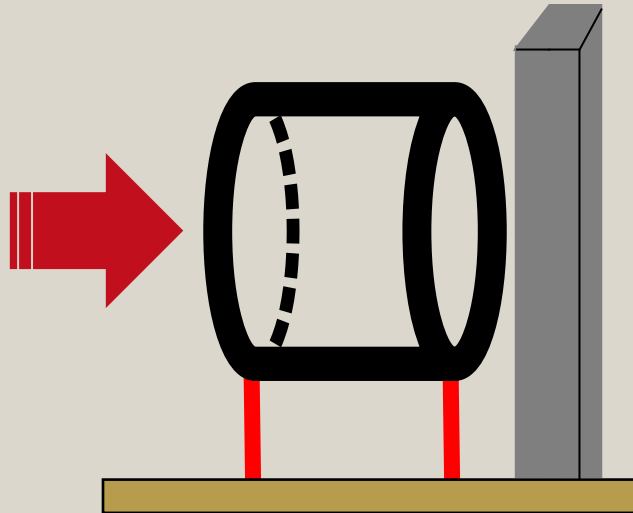

Reveal Ceramic Face
48 sec



Taylor Larson

Critical Targets

Integrate with Pallet
297 in²

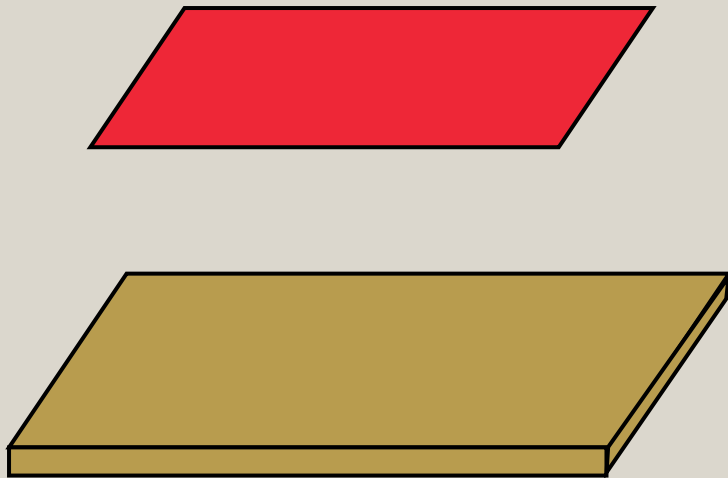

Fit Return System
6 in

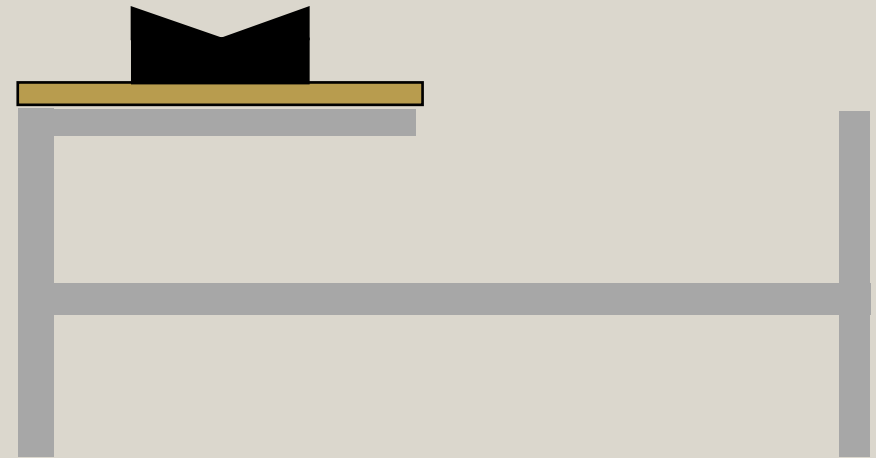

Taylor Larson

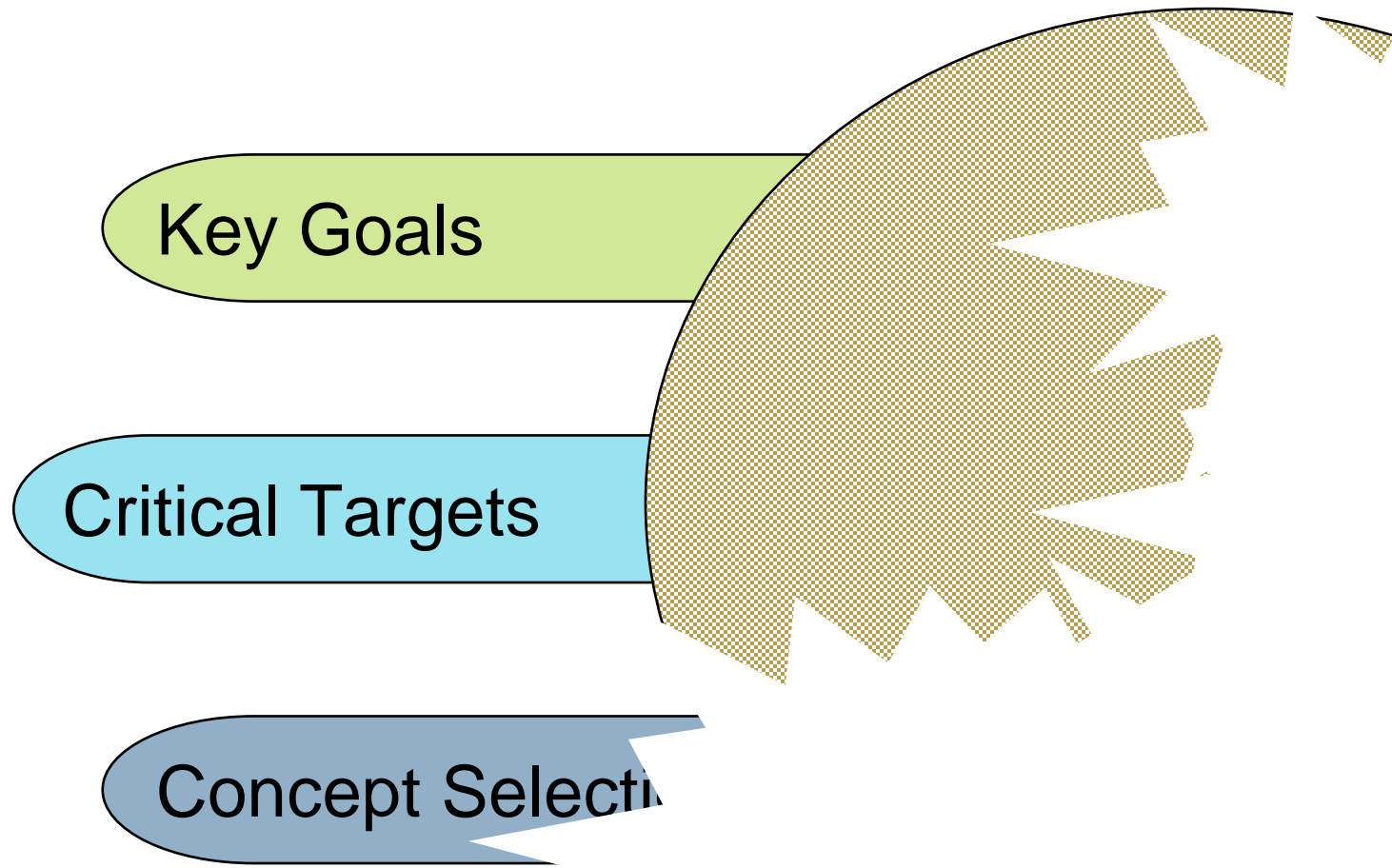

Taylor Larson

Concept Generation Tools

Biomimicry



Brainstorming



Crapshoot

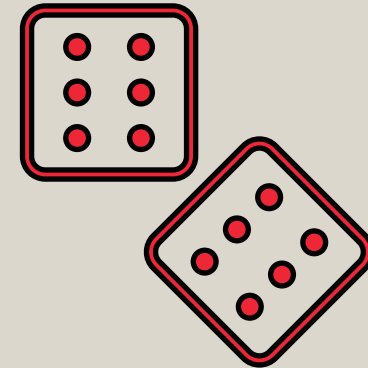

Taylor Larson

Top 3 Concepts Generated

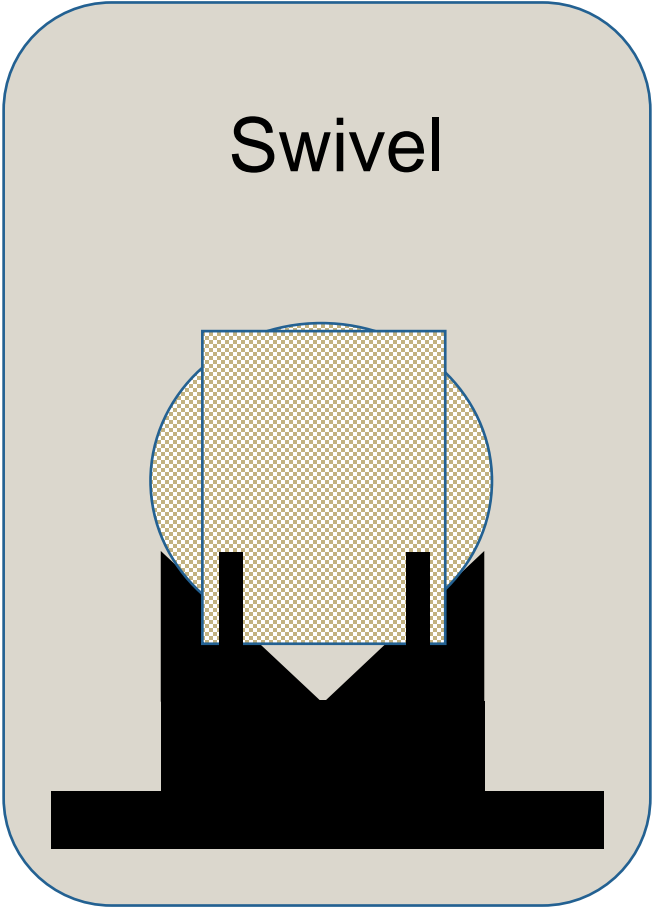
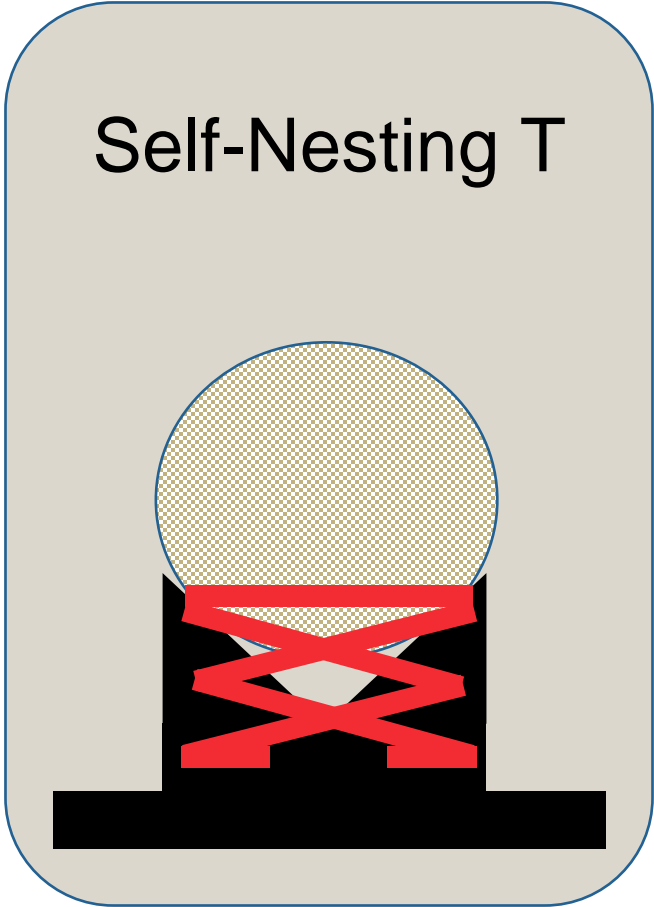
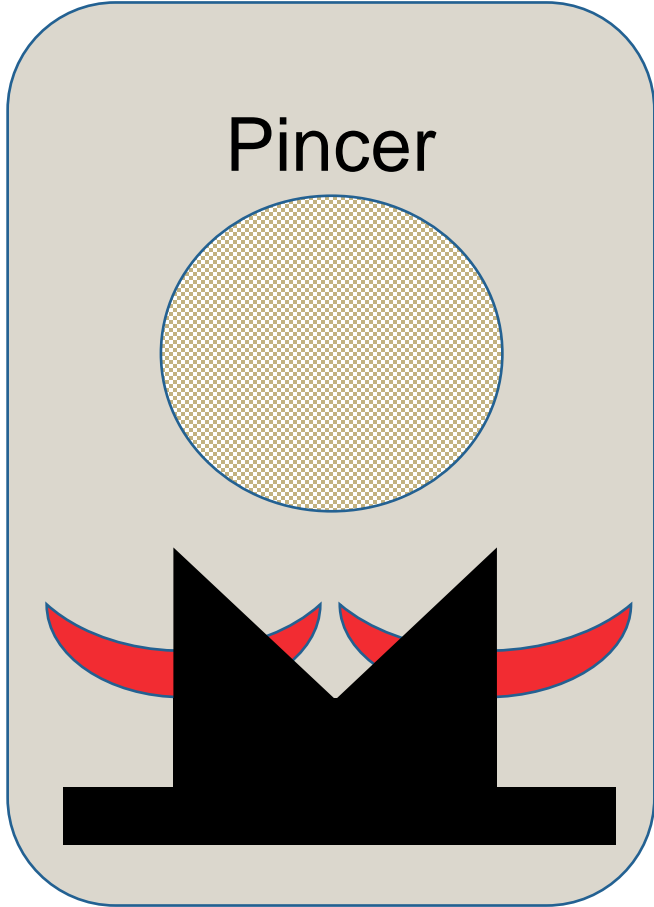

Taylor Larson

Concept Selection

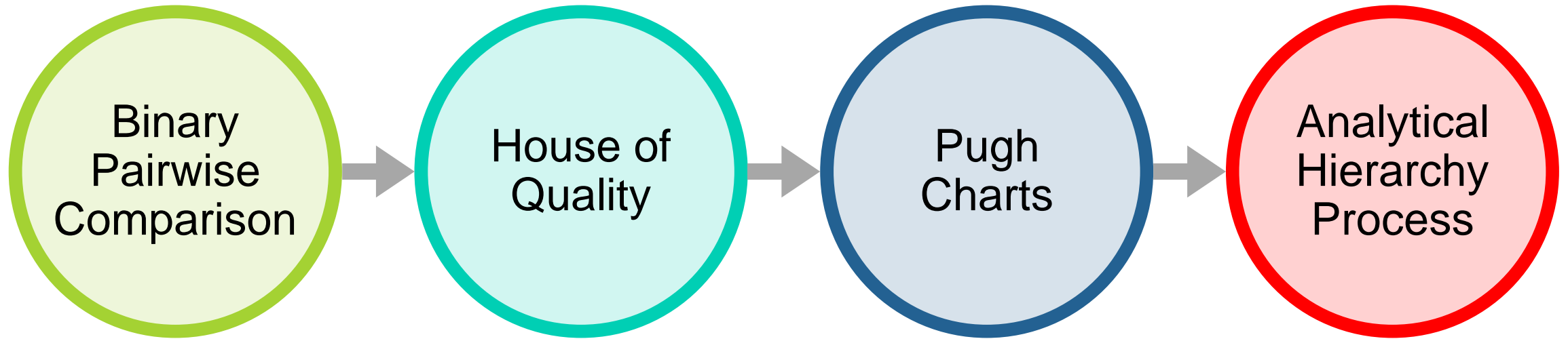

Taylor Larson

Final Selection

Self-Nesting T

- Similar to working design
- Trigger activated and collapsible
- Uses mechanism on conveyor to activate



Taylor Larson

Key Goals

Critical Targets

Concept Selection

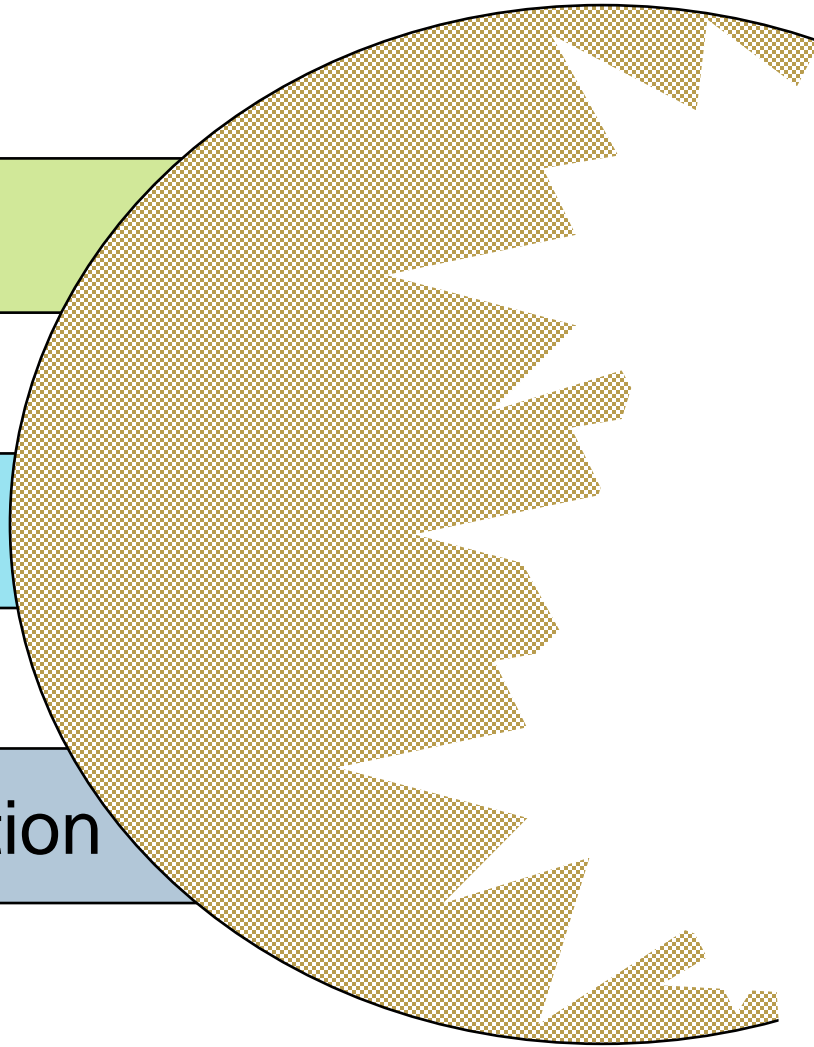

Design Update

Jared White

Design Update

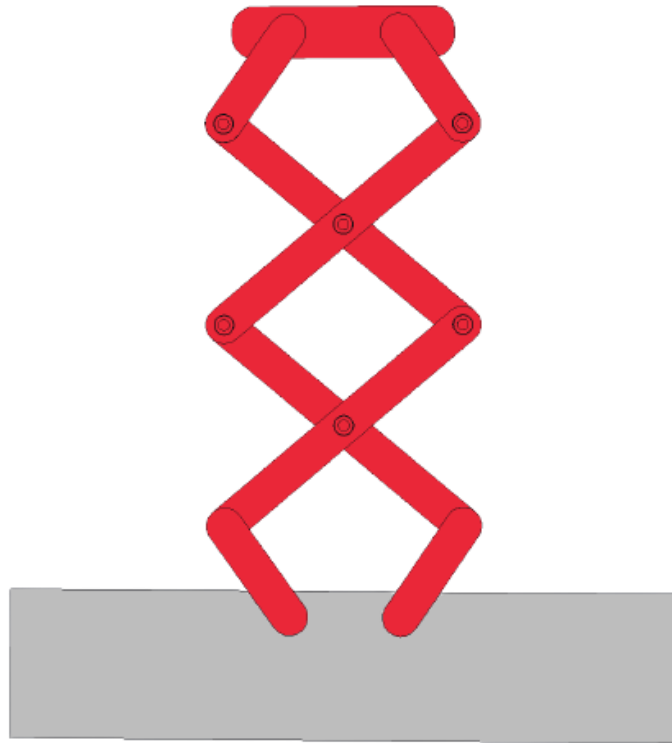

Original Design

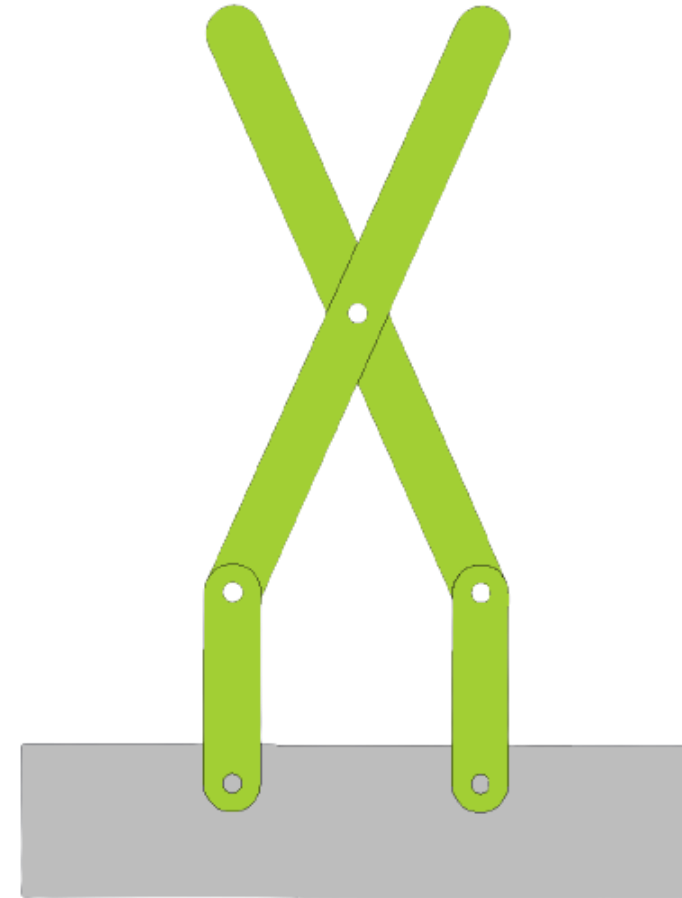

Current Design

Jared White

Vertical Retraction and Expansion

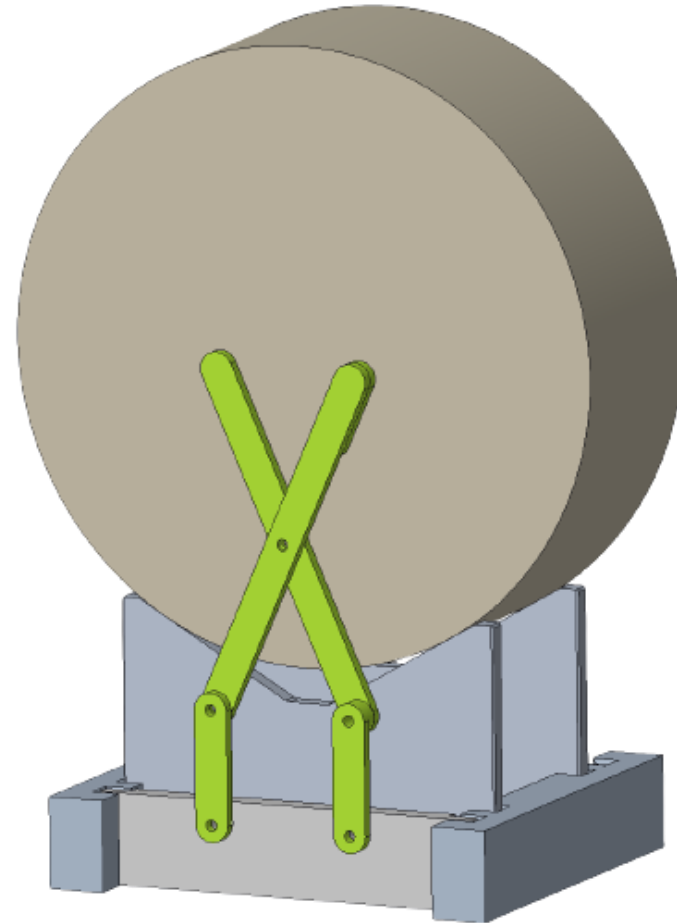
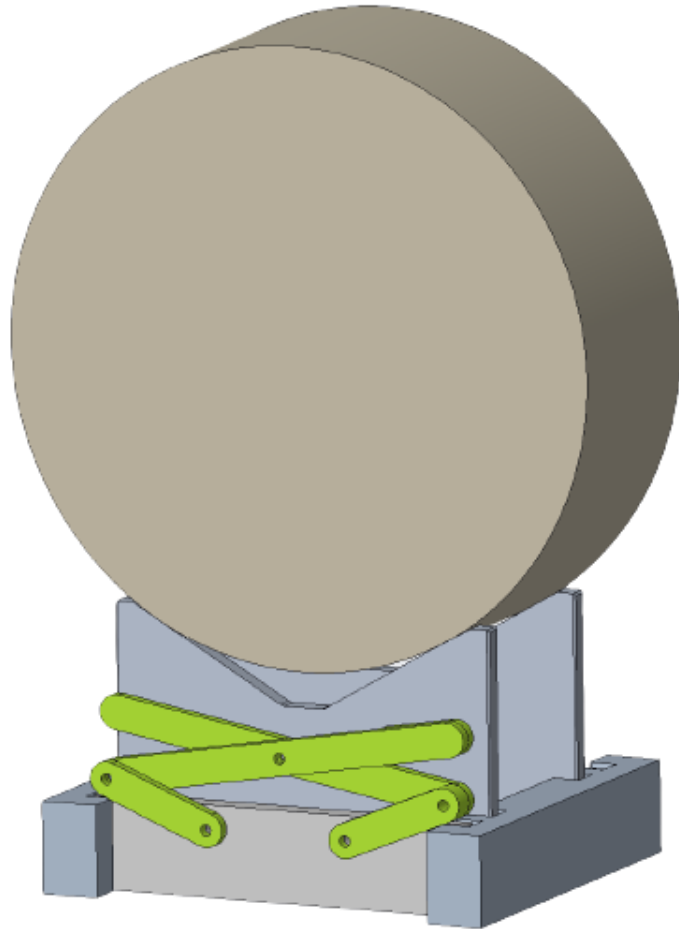

Jared White

Vertical Retraction and Expansion

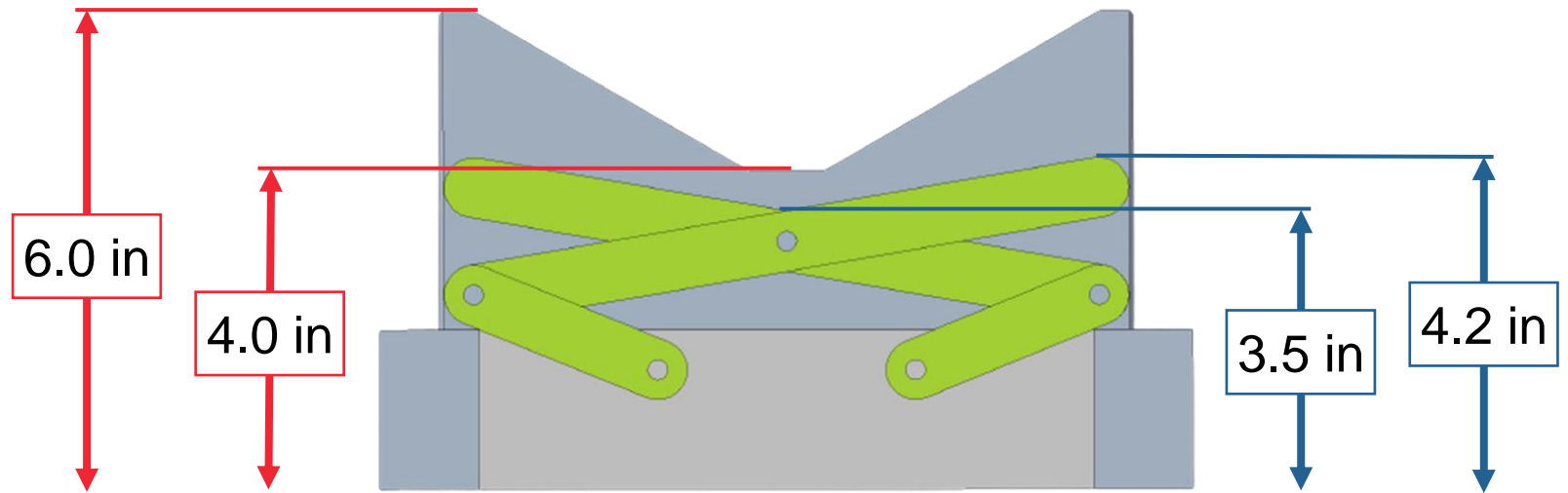
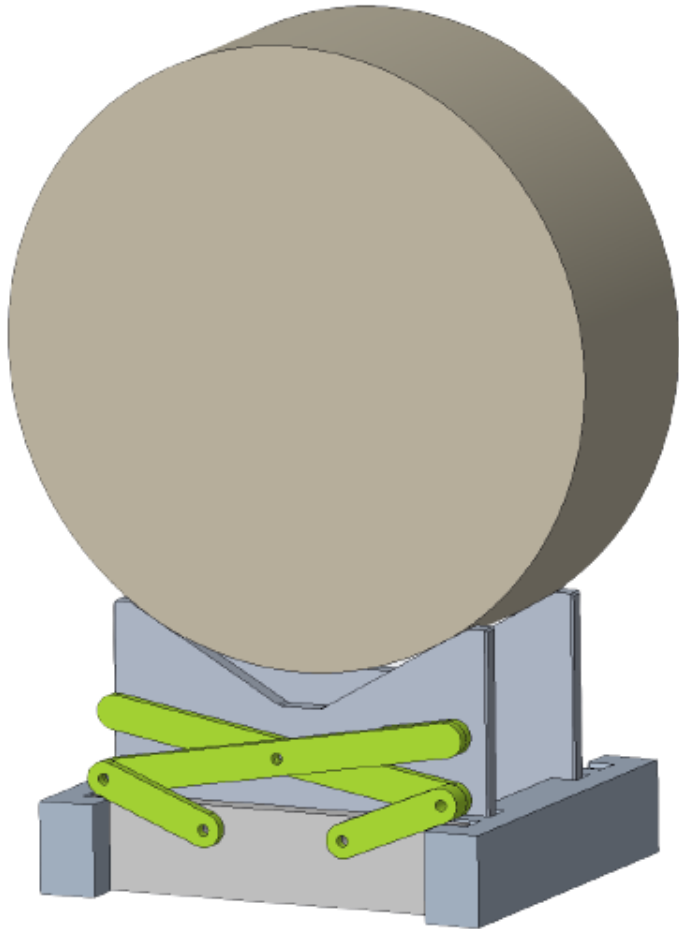

Jared White

Vertical Retraction and Expansion

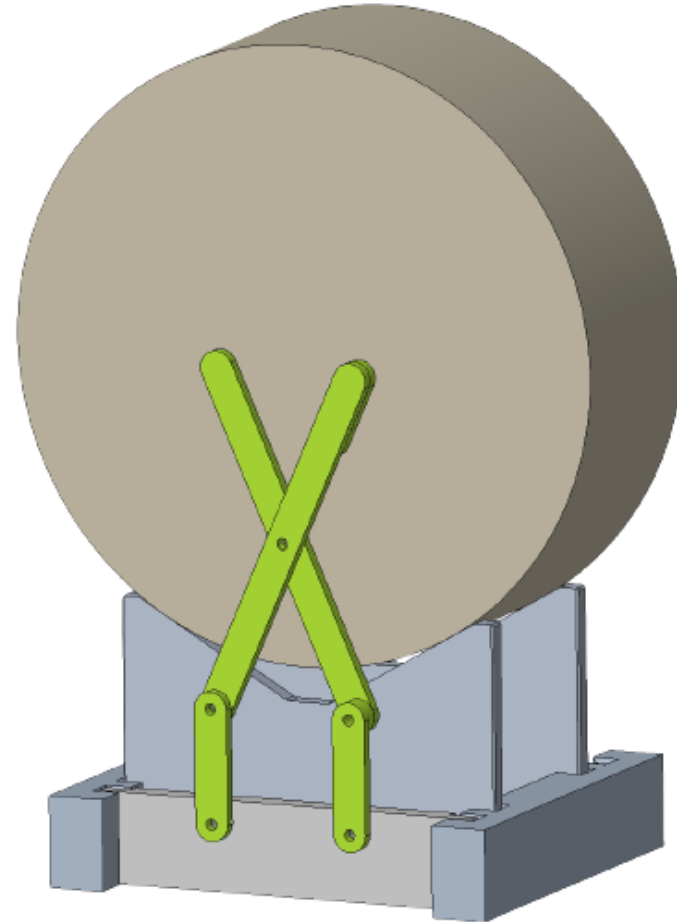
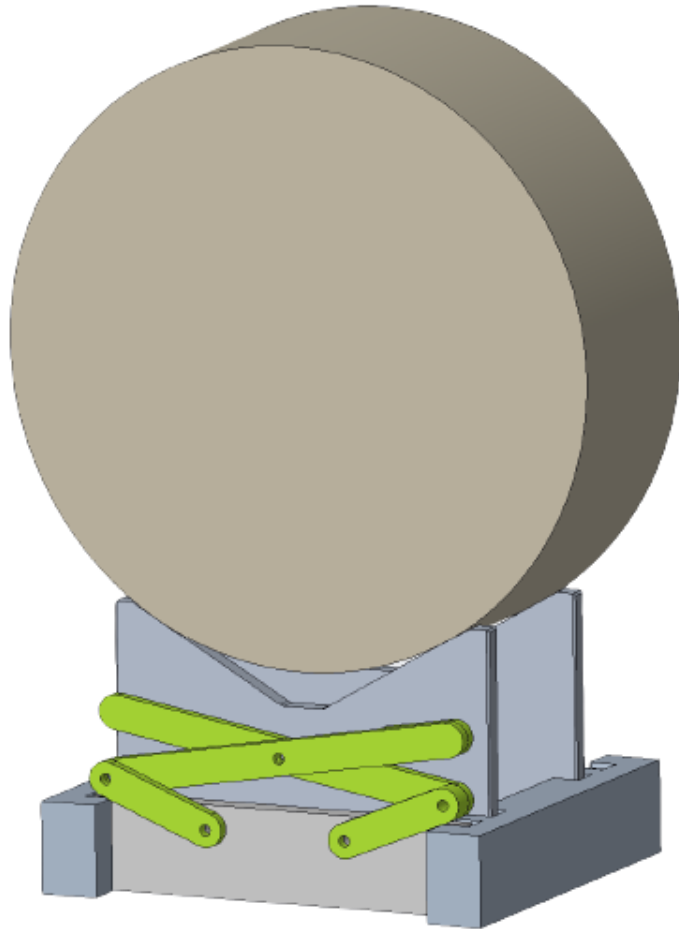

Jared White

Vertical Retraction and Expansion

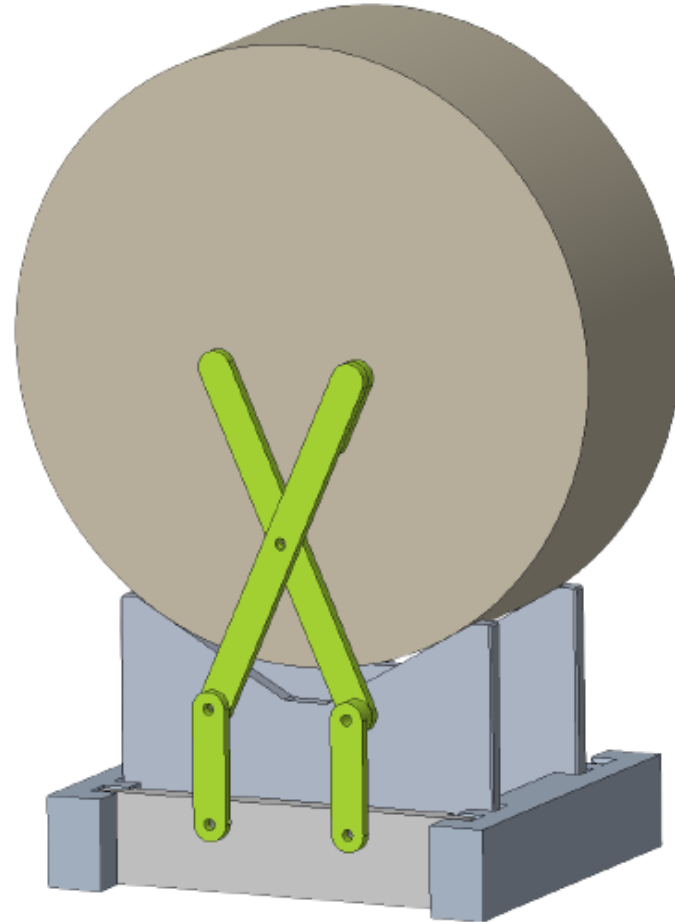
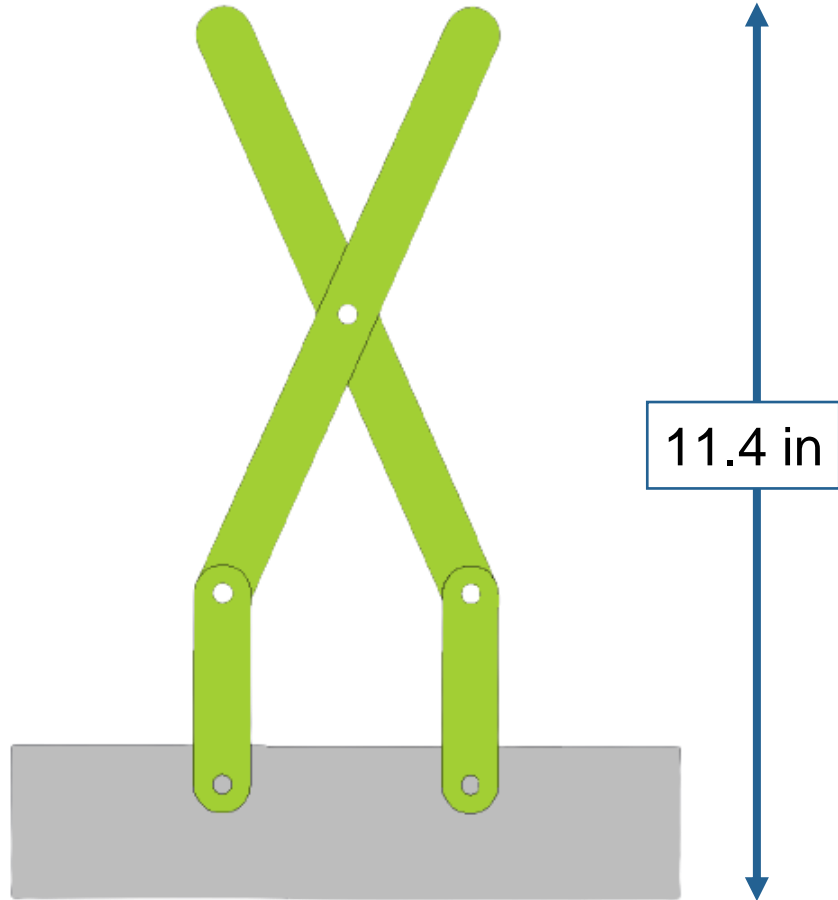

Jared White

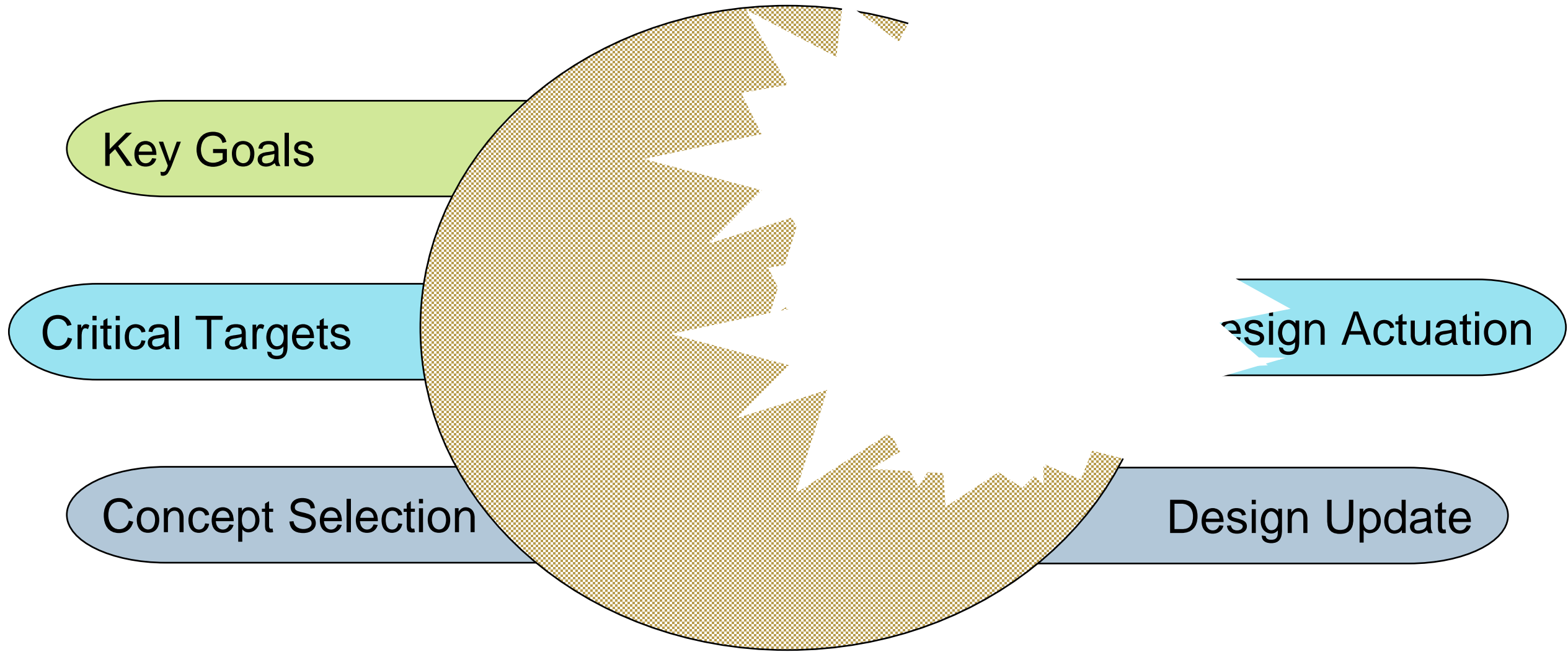

Jared White

Vertical Retraction and Expansion

Gear and Rack Slider

- “Z” shaped rack allows simultaneous rotation
- Slides in a slot on the outer wall
- Raised outer wall allows for particle flow

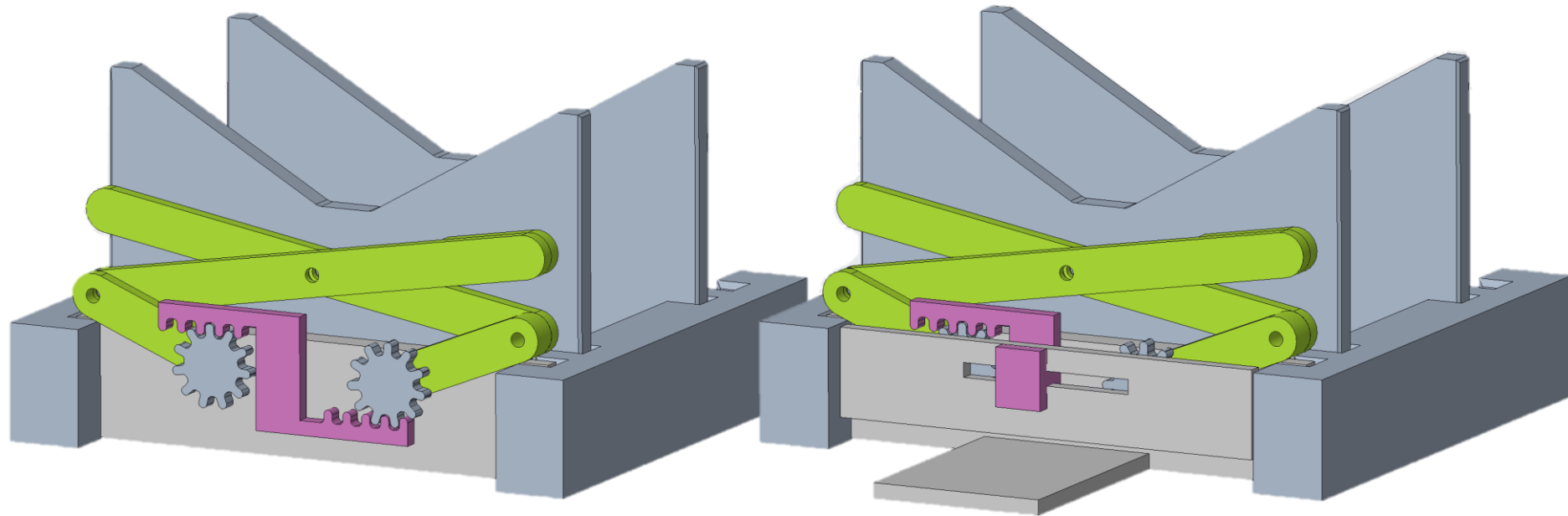

Jared White

Vertical Retraction and Expansion

Slider Joint and Switch

- The rack will act as a slider
- Slotted joint connection will allow for rotation of the switch

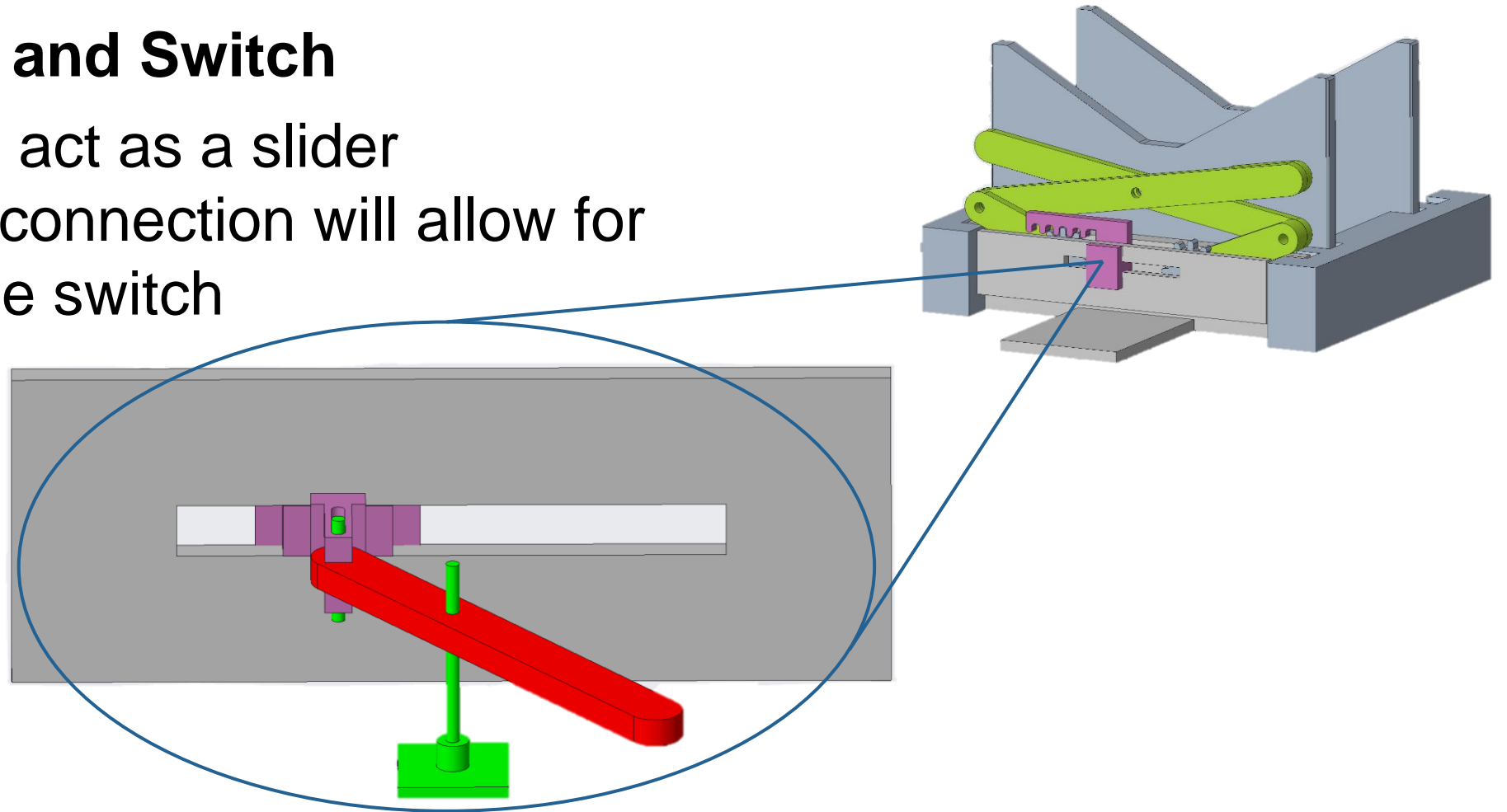

Jared White

Vertical Retraction and Expansion

Slider Joint and Switch

- The rack will act as a slider
- Slotted joint connection will allow for rotation of the switch

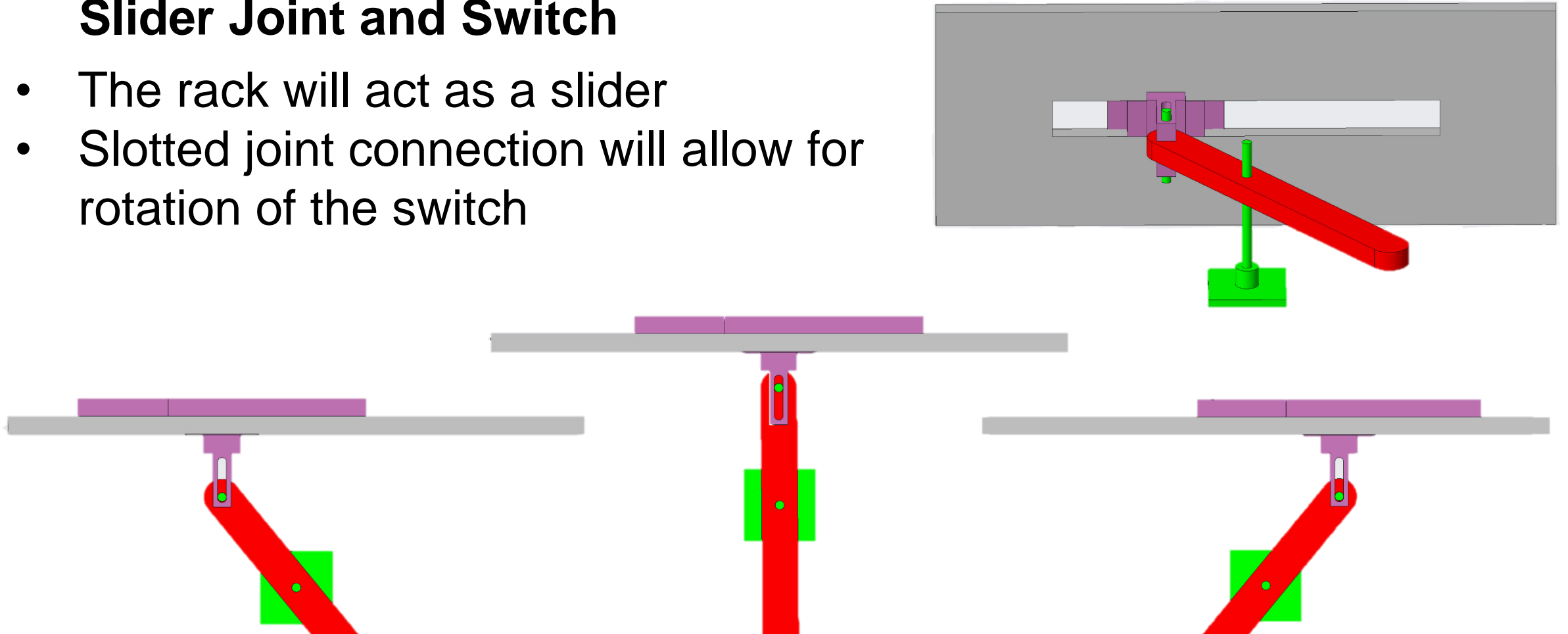

Jared White

Material Selection

Base and Linkages

- Aluminum 6061

Joints

- Alloy steel shoulder bolts

Washers and Spacers

- UHMW Polyethylene

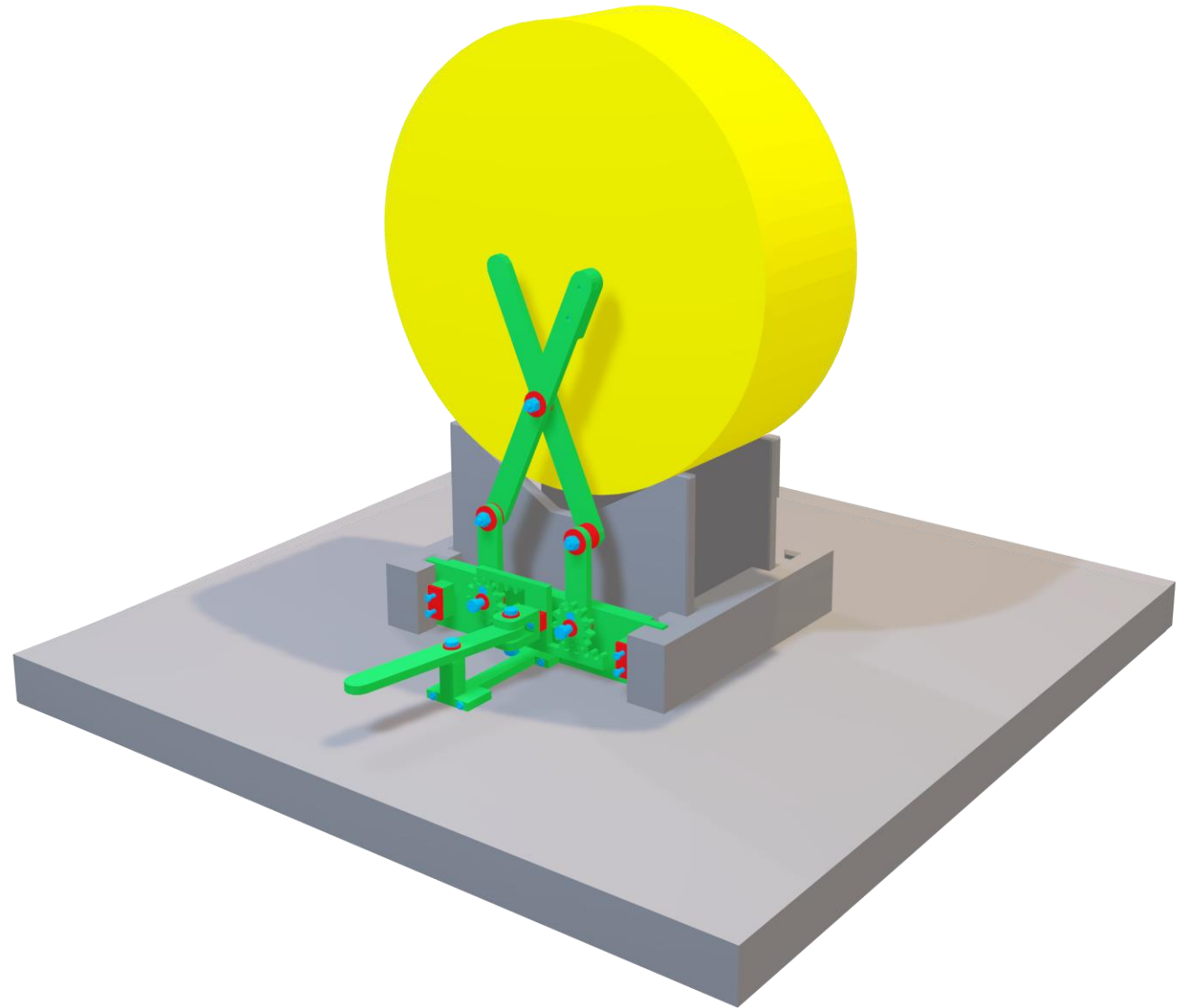

Jared White

Key Goals

Conceptual Design

Critical Targets

Design Actuation

Concept Selection

Design Update

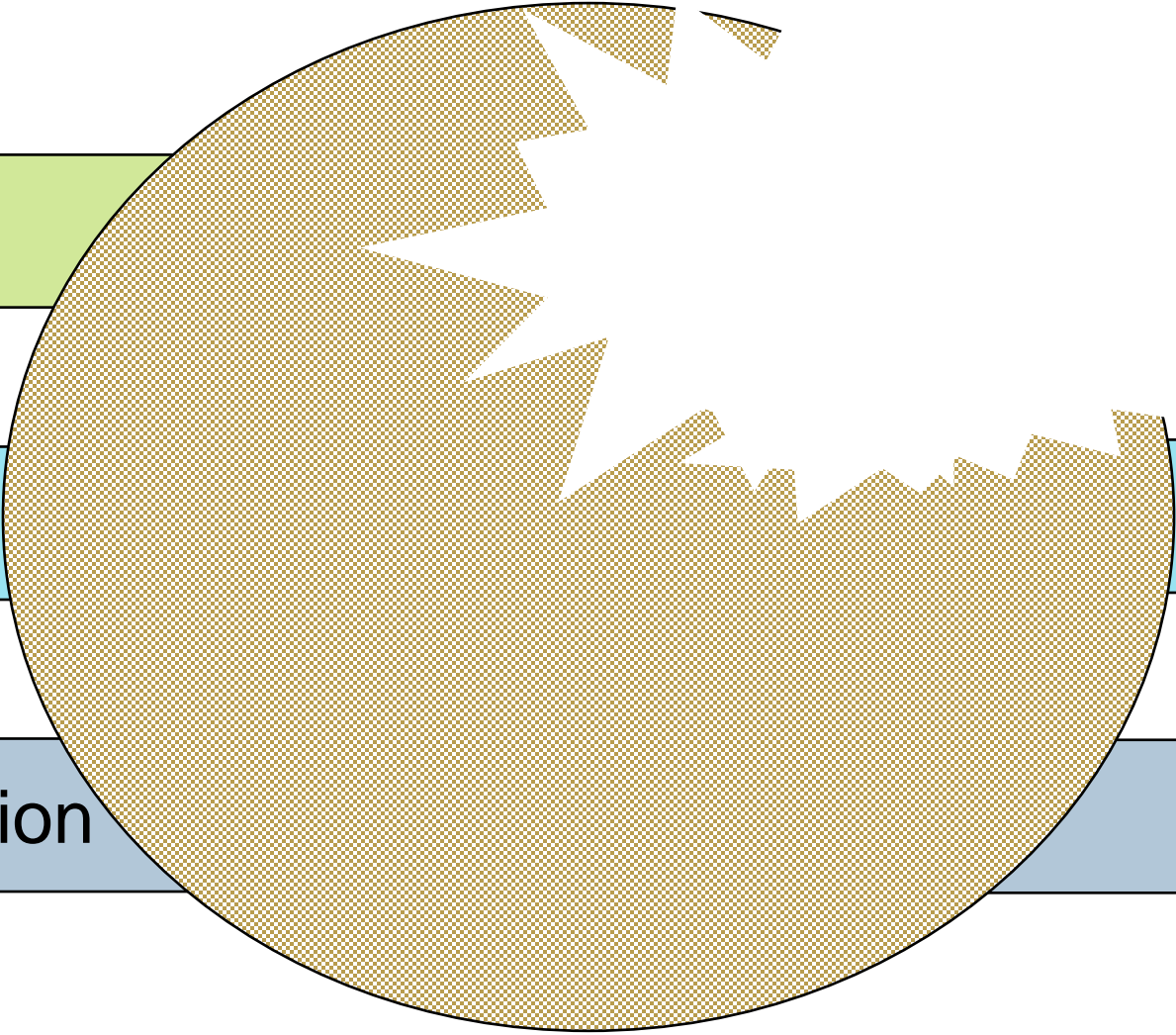

Pawel Grum

OVERHANGS

Full Design

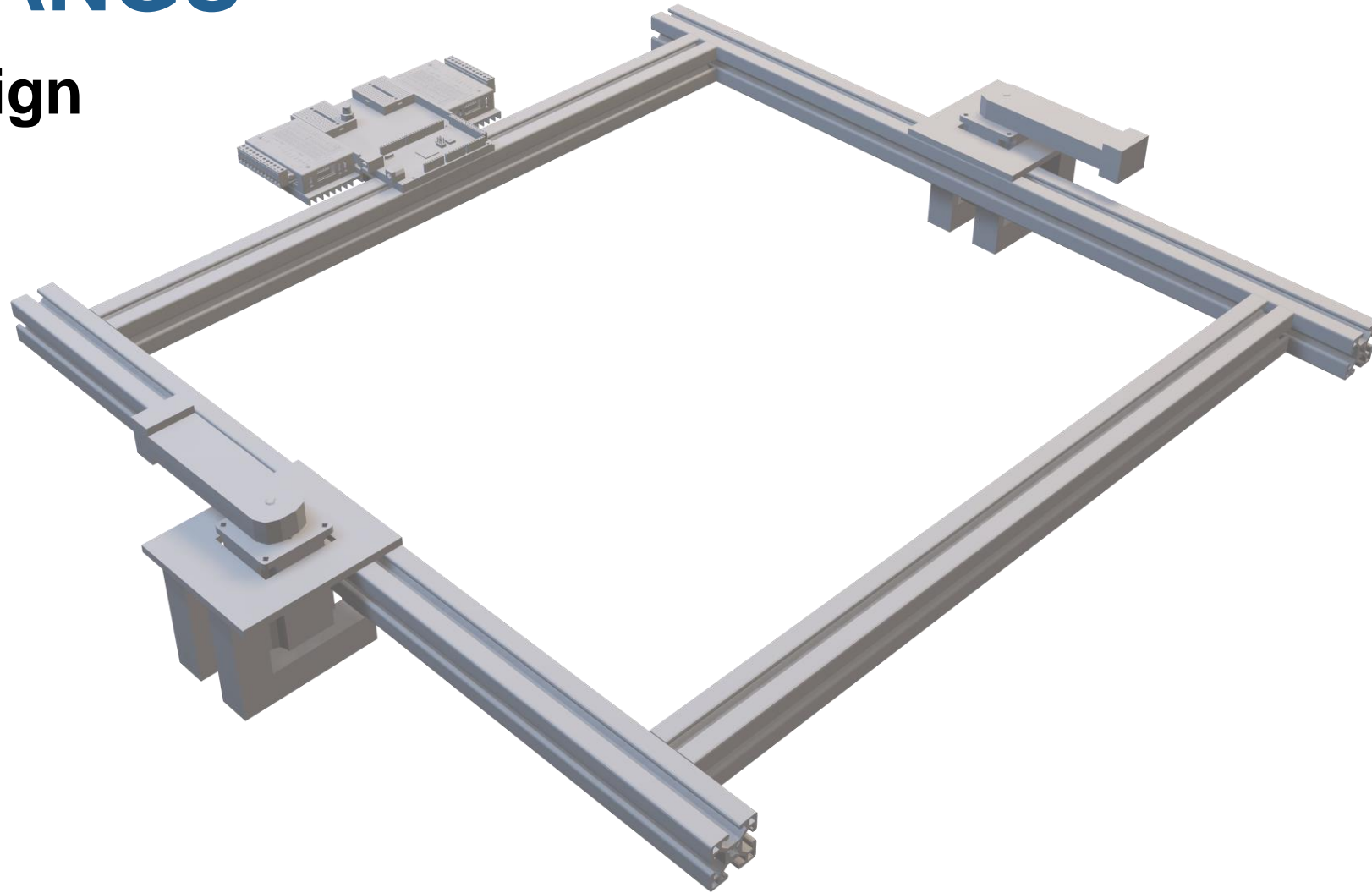

Pawel Grum

OVERHANGS

Full Design

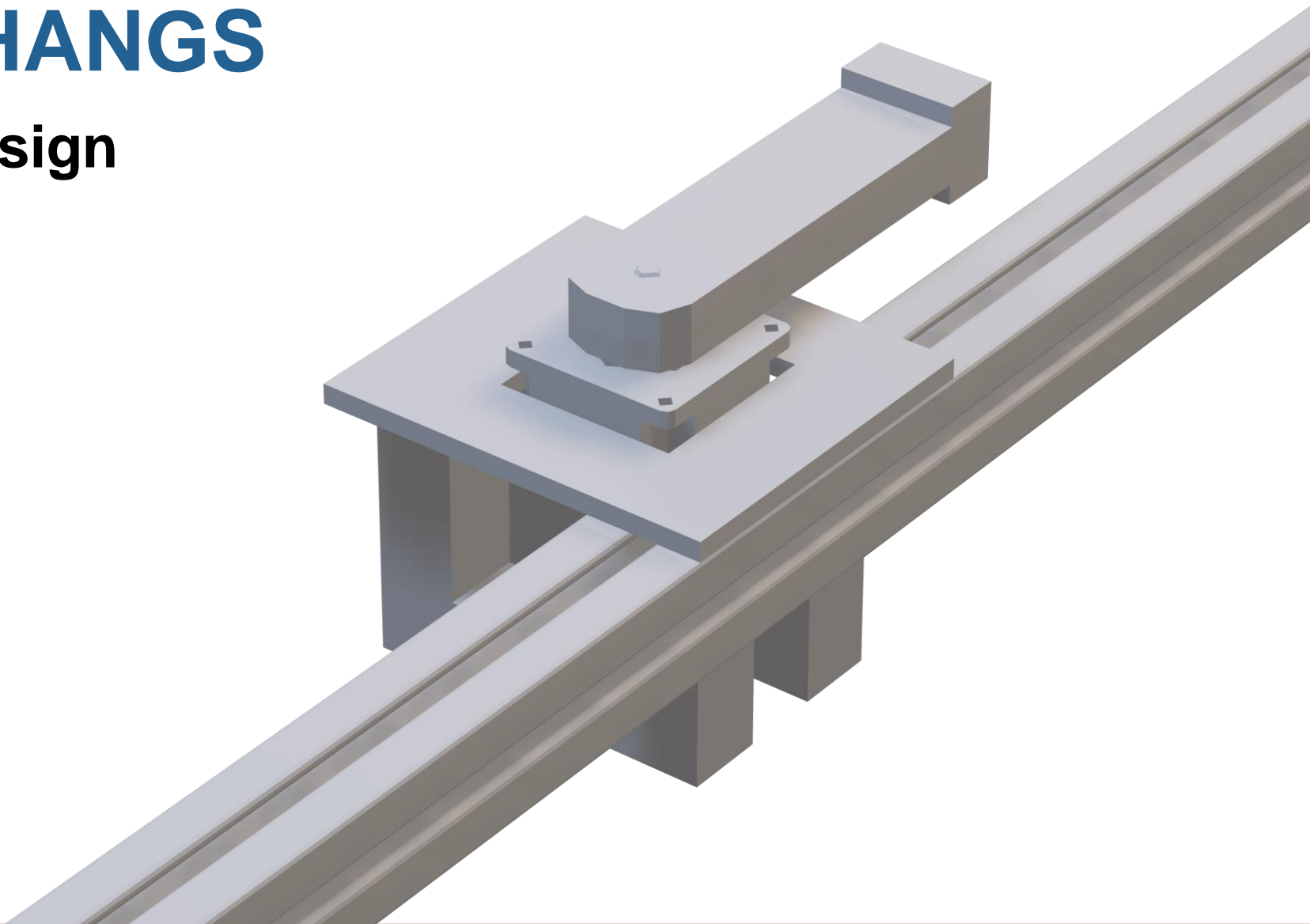

Pawel Grum

OVERHANGS

Full Design

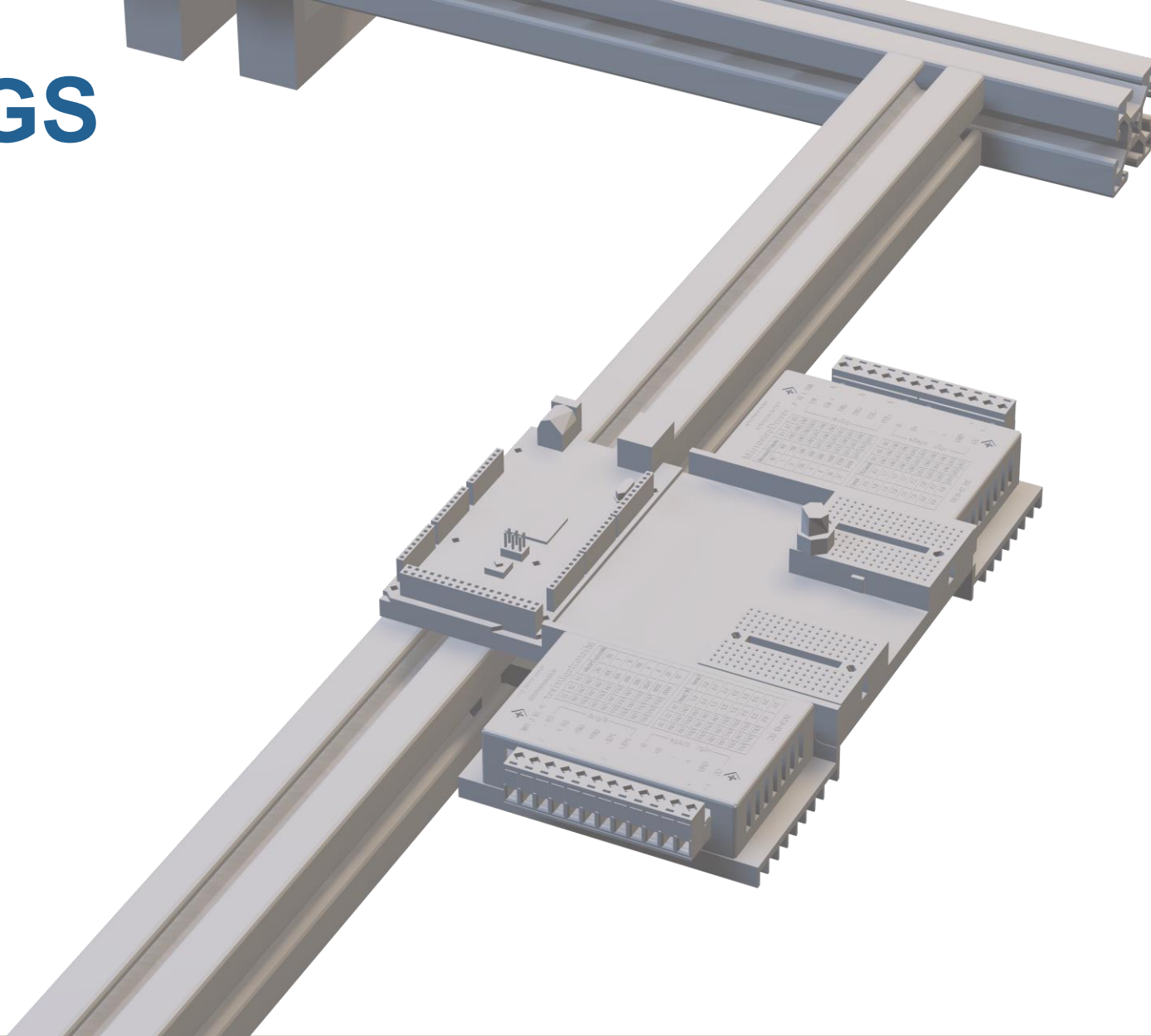

Pawel Grum

OVERHANGS

Automation Center

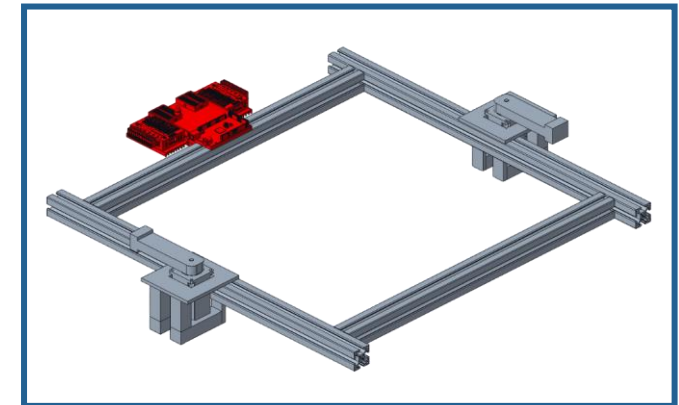
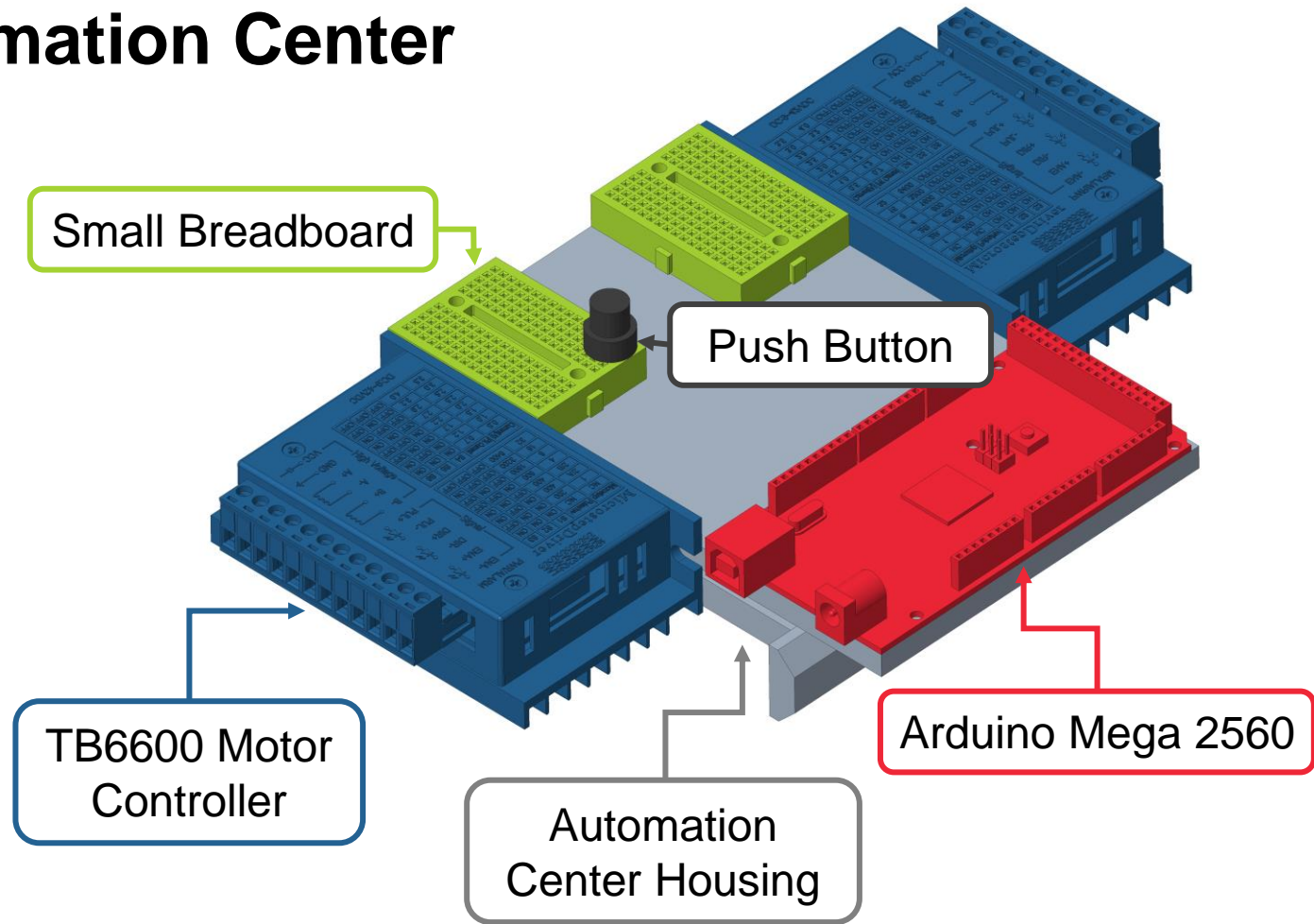

Pawel Grum

OVERHANGS

Automation Center Housing

Side View

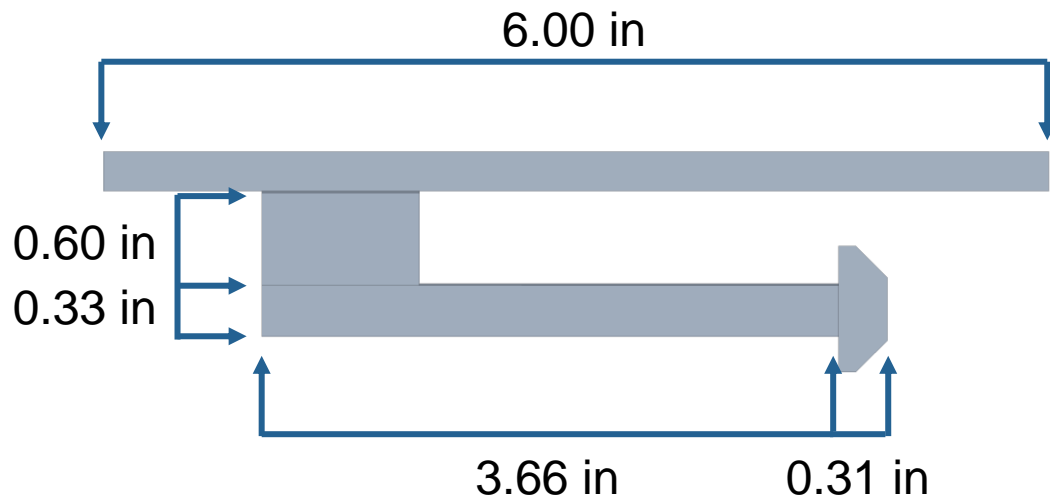

Front View

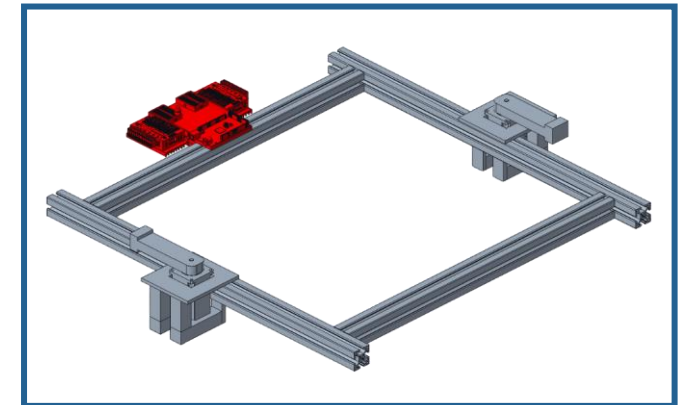
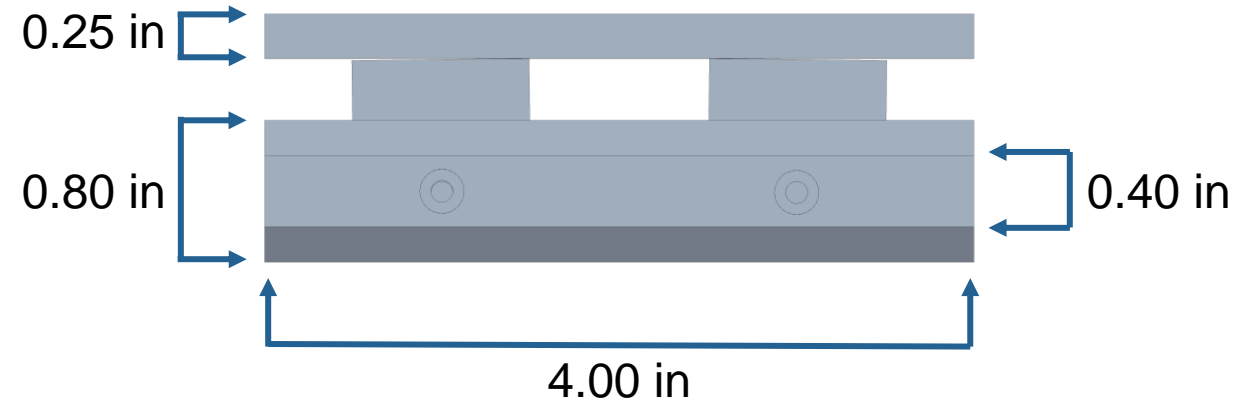

Pawel Grum

OVERHANGS

Motor Mount

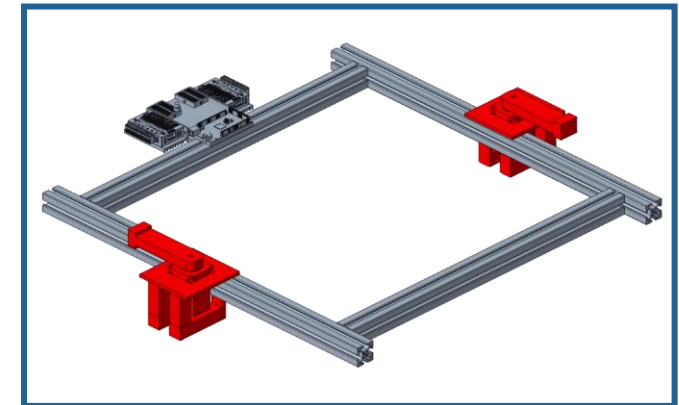
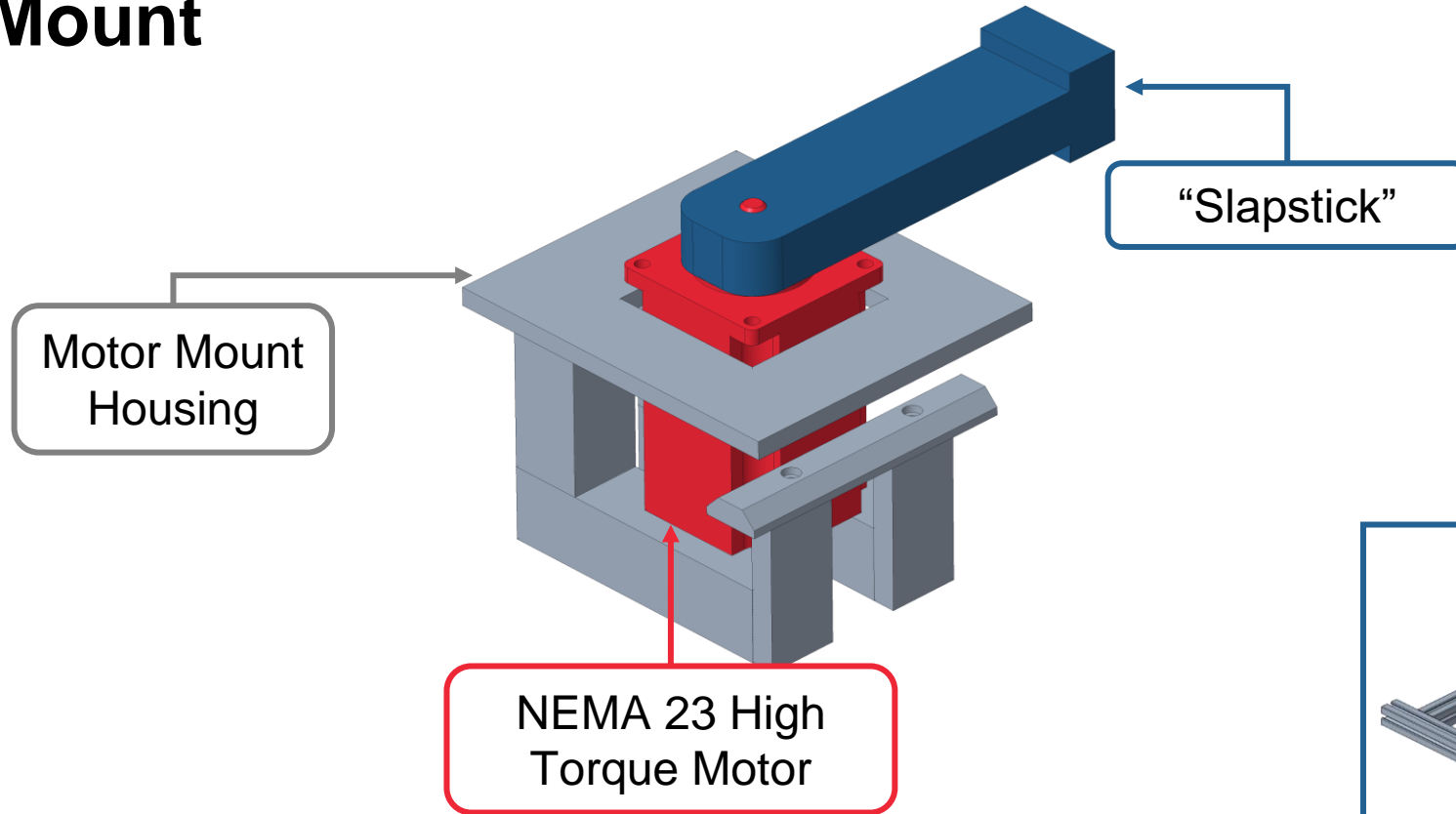

Pawel Grum

OVERHANGS

Motor Mount Housing

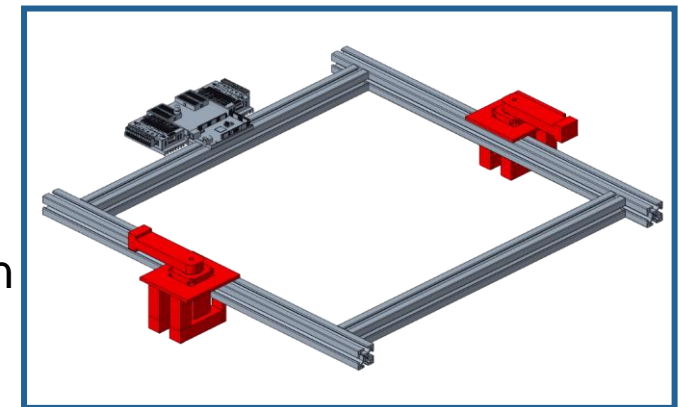
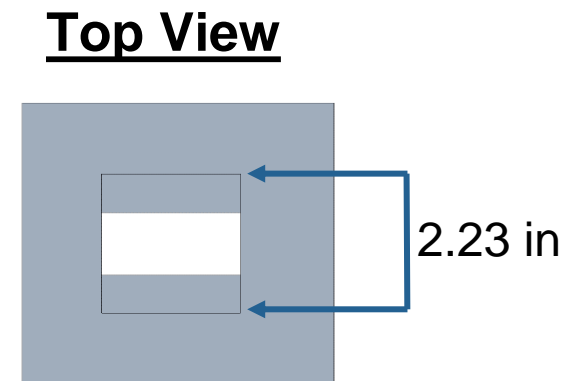
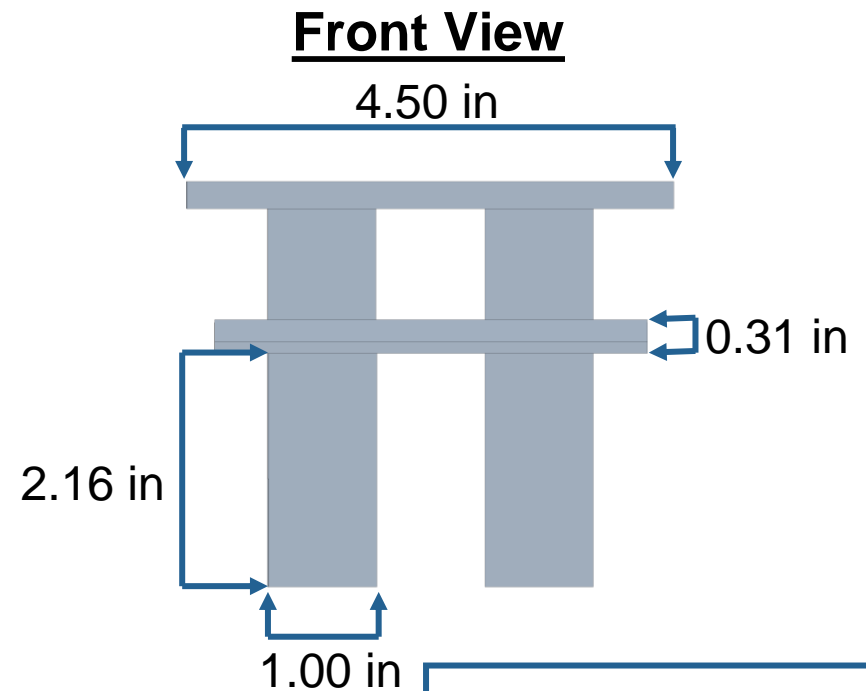
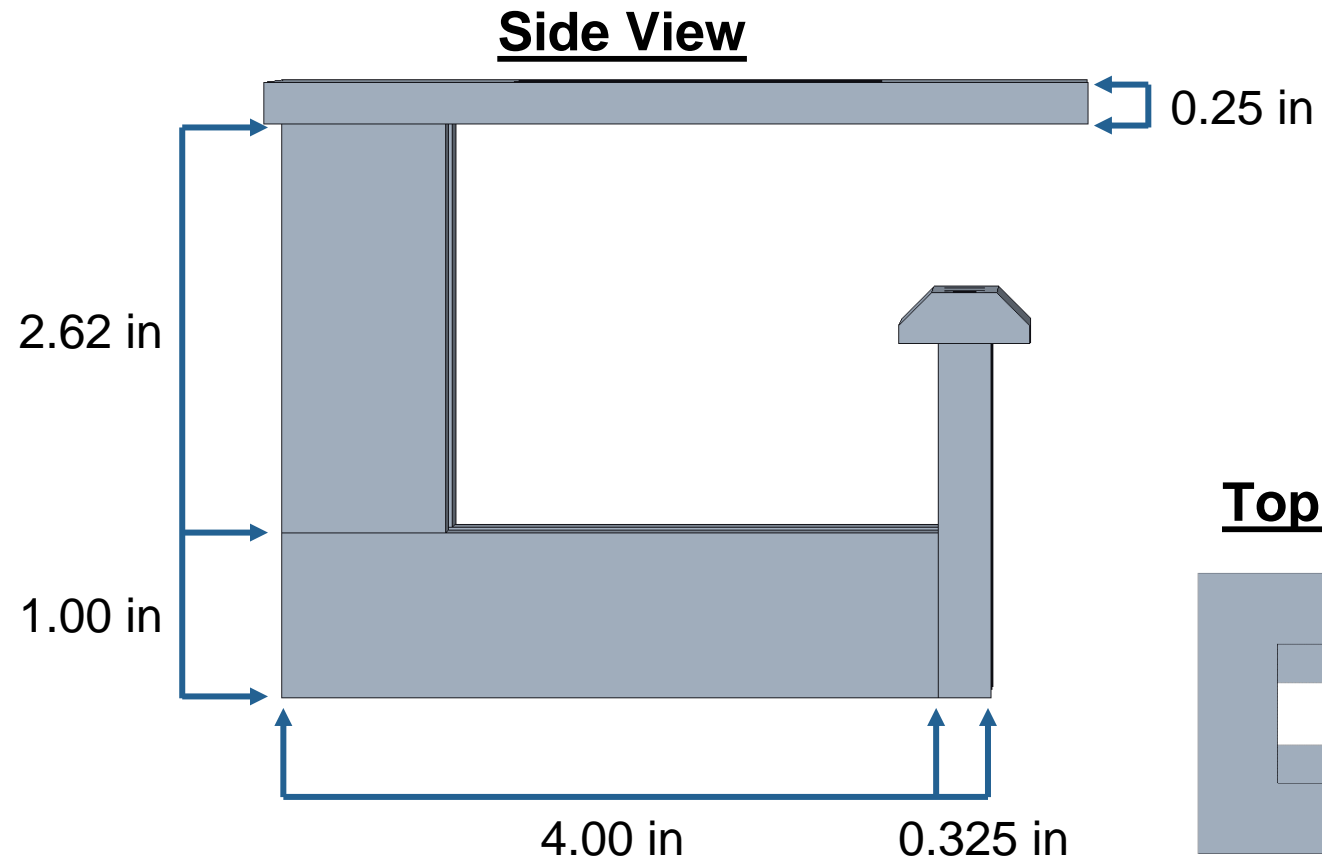

Pawel Grum

CONNECTION MAP

Flow Chart for Electronics

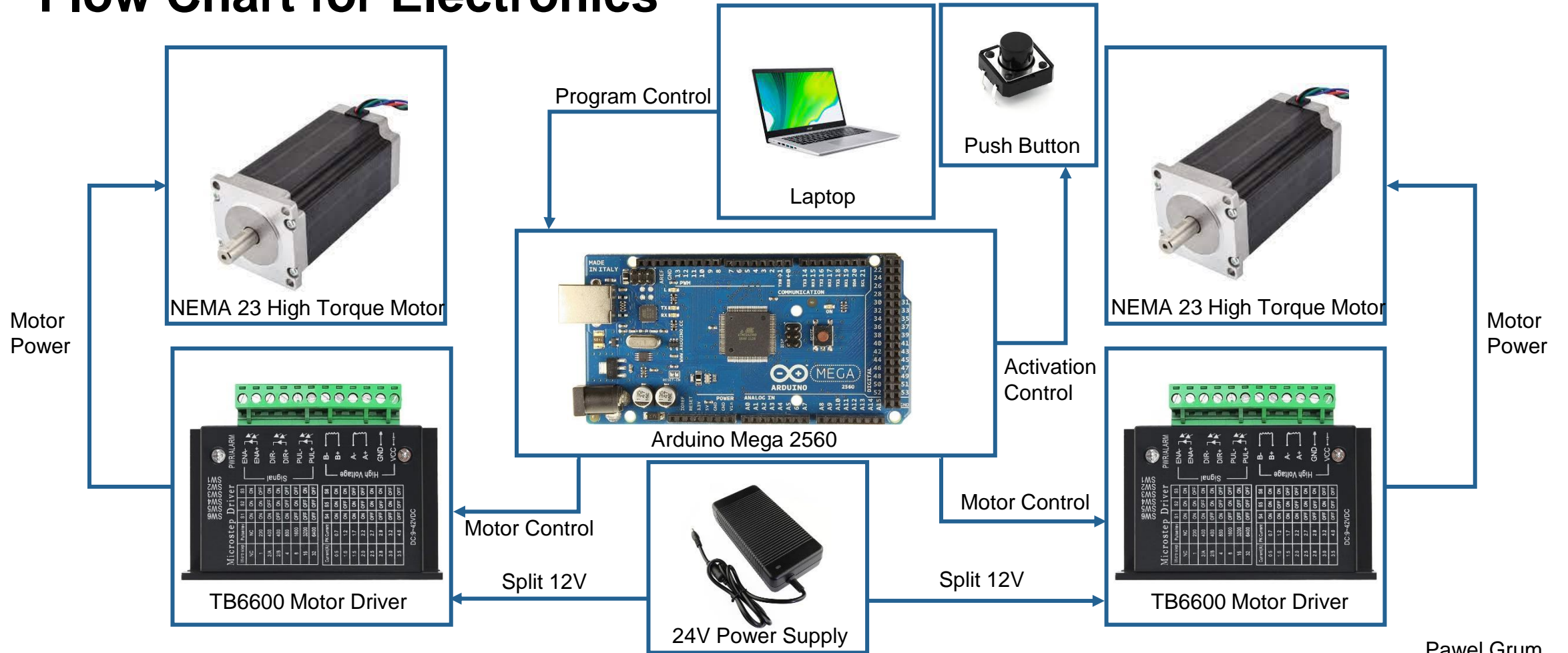

Pawel Grum

CONNECTION MAP

Corning RFID Integration

Our System



Corning's System



Integration

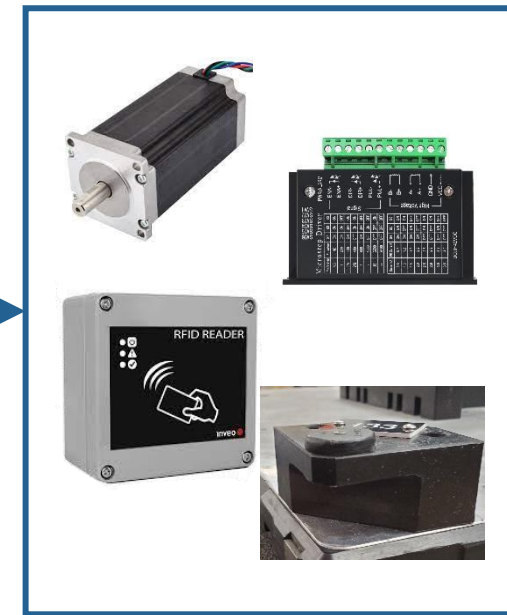

Pawel Grum

BUDGET BREAKDOWN

Expense Reporting

Project budget \$2000

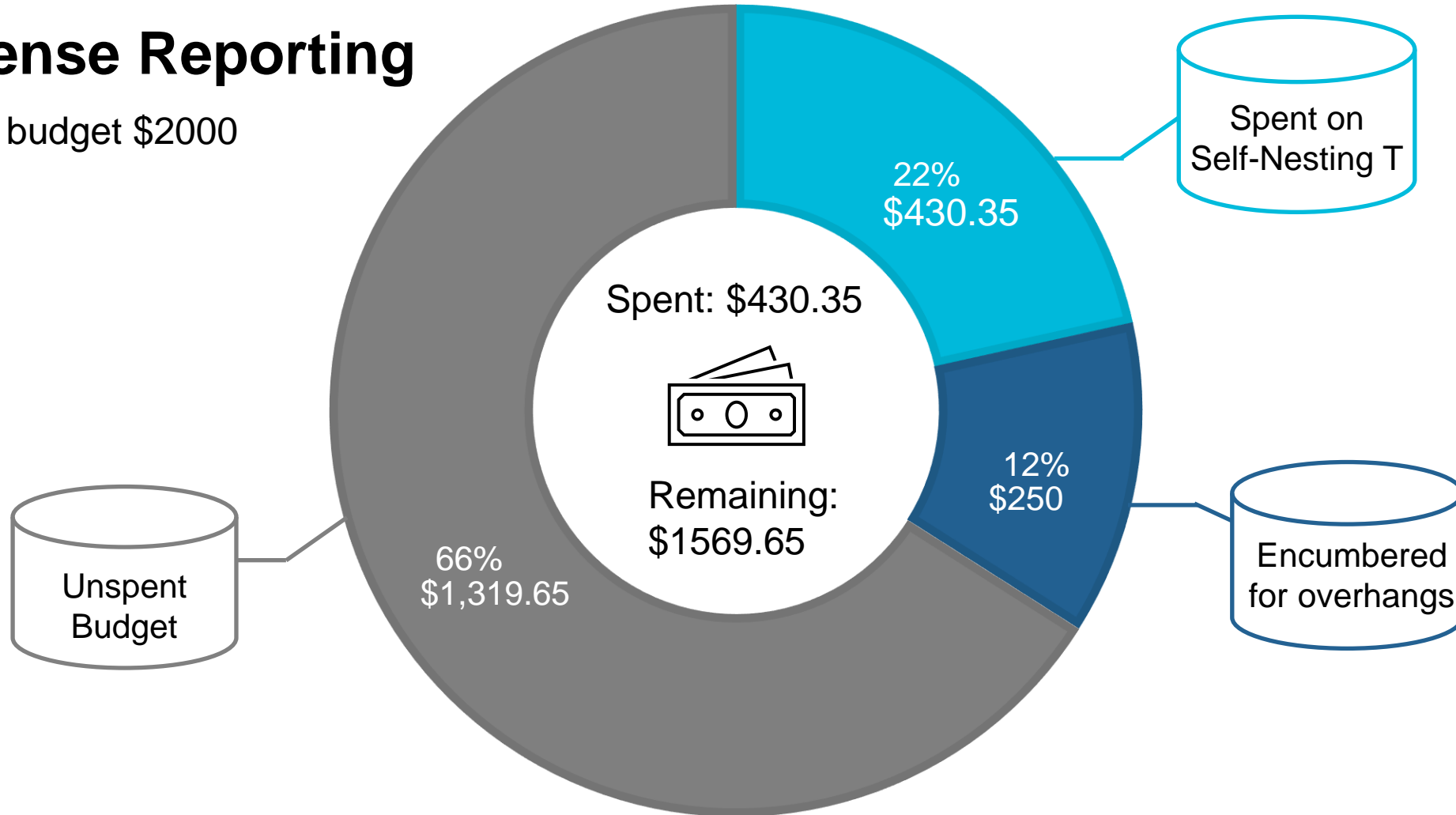

Pawel Grum

BUDGET BREAKDOWN

Spending Breakdown

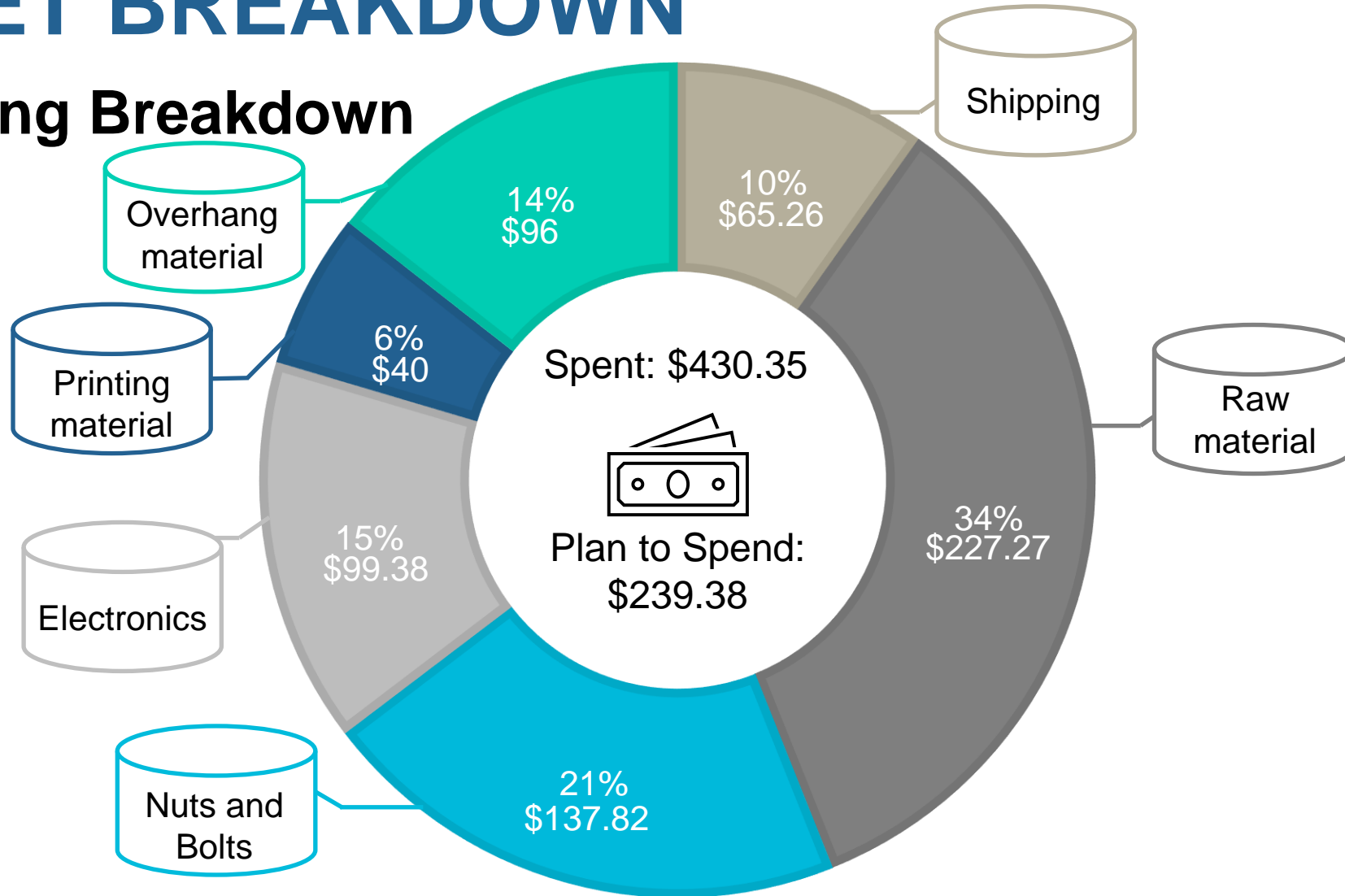

Pawel Grum

CURRENT CHALLENGES

- Finalize motorized overhang component selection
 - ❑ Determine final materials, motor type, and connection type
- Finalize motorized overhang CAD
 - ❑ Get CAD machine shop approved, order parts, and begin machining
- Test mechanisms durability
 - ❑ Mobility during harsh conditions, impact resistance, material resistance
- Improving initial prototype
 - ❑ Improvement to design, and functionality

Pawel Grum



FUTURE WORK

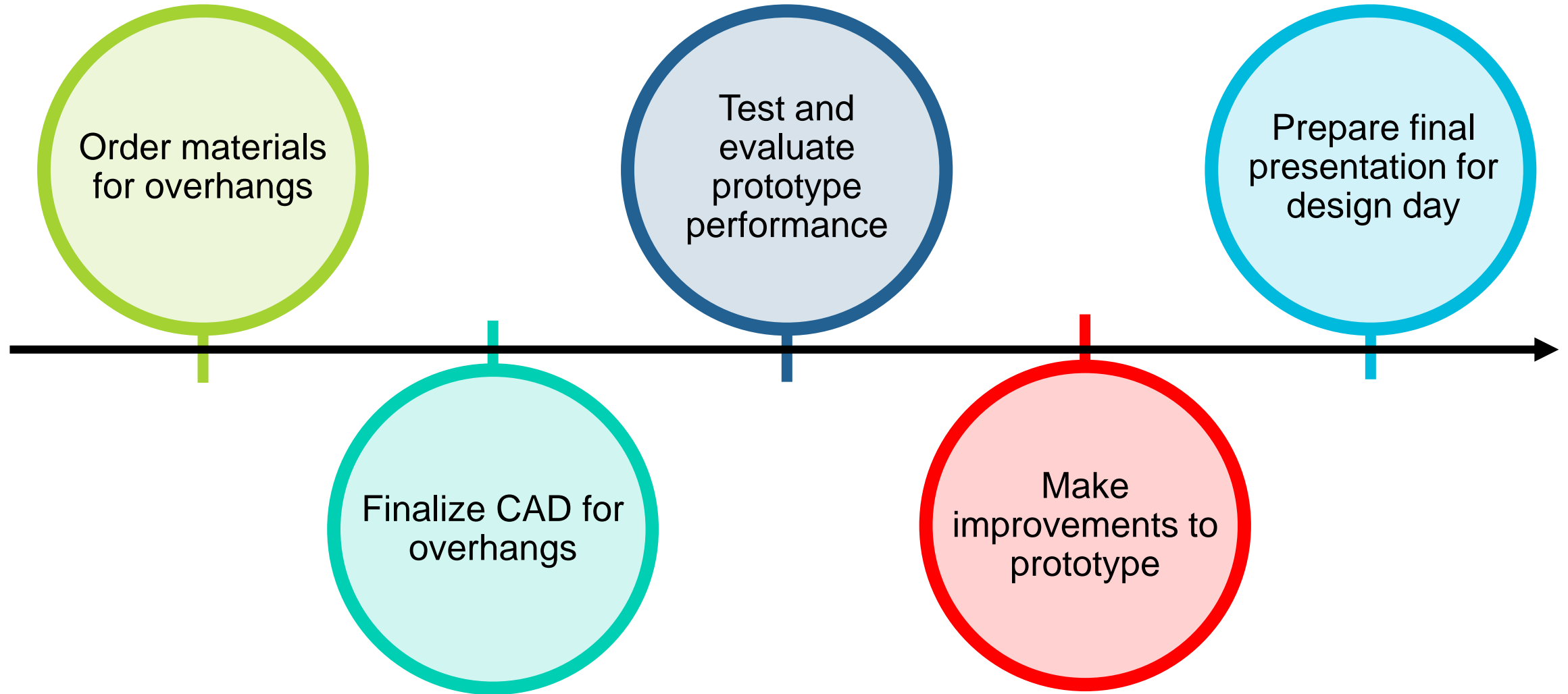

Pawel Grum

Thank you!

Pawel J. Grum | Robert C. Kosmas | Taylor M. Larson | Segundo A. Sanchez | Jared T. White

pjg17@fsu.edu

rck19a@fsu.edu

tml18bg@fsu.edu

sas19x@fsu.edu

jtw18c@fsu.edu

