

Team 518 Operation Manual

Jonathan Draigh, Emily Haggard, Mohamad Kassem, Martin Senf, Andrew Walker

Mechanical Engineering Department, FAMU-FSU College of Engineering

EML 4552C: Senior Design 2

Dr. Shayne McConomy

Mar. 25, 2022

Table of Contents

Table of Figures	3
Project Overview	4
Project Description	4
Project Objective	5
Key Goals	5
Assumptions	5
Component/Module Description	6
Basket Module	6
Base Module	8
Motor Housing Module	9
Wiring/Powering Module	11
Basket Bracket/Bearing Housing Module	12
Flotation with Concentric Pipe Module	15
Operation	18
Troubleshooting	19
Appendix A – Machine Drawings	20
Appendix B – Ordered Parts List	39

Table of Figures

Figure 1: Trash Interceptor	4
Figure 2: Full Basket Module.....	7
Figure 3: Exploded View of Full Basket	7
Figure 4: Full Base Module.....	8
Figure 5: Full Base Module, Exploded View	9
Figure 6: Motor Housing Assembled.....	10
Figure 7: Motor Housing Exploded	10
Figure 8: Wiring Diagram	11
Figure 9: Assembled Wiring Diagram.....	12
Figure 10: Bracket and Bearing Housing Assembled	13
Figure 11: Bracket and Bearing Housing Exploded	14
Figure 12: Reservoir Basket with UHMW	14
Figure 13: Assembled Buoy Connection	16
Figure 14: Exploded Buoy Connection	16
Figure 15: Full Trash Interceptor with all modules.....	17
Figure 16: Full Assembly Drawing	21
Figure 17: Full Basket Assembly.....	22
Figure 18: Assembled Motor Housing Bottom	23
Figure 19: Basket Support/Outline	24
Figure 20: Motor Housing Bottom	25
Figure 21: Motor Housing Bottom Walls	26
Figure 22: Rectangular Tubes.....	27
Figure 23: Inner Concentric Pipes	28
Figure 24: Bearing Housing	29
Figure 25: Basket Bracket	30
Figure 26: Basket Wall	31
Figure 27: Basket Mesh.....	32
Figure 28: Motor Housing Top	33
Figure 29: Center Shaft	34
Figure 30: Base L, two of these make up the base	35
Figure 31: Full Base Assembly.....	36
Figure 32: Concentric Pipe Plate	37
Figure 33: Buoy Connector Plate	38

Project Overview

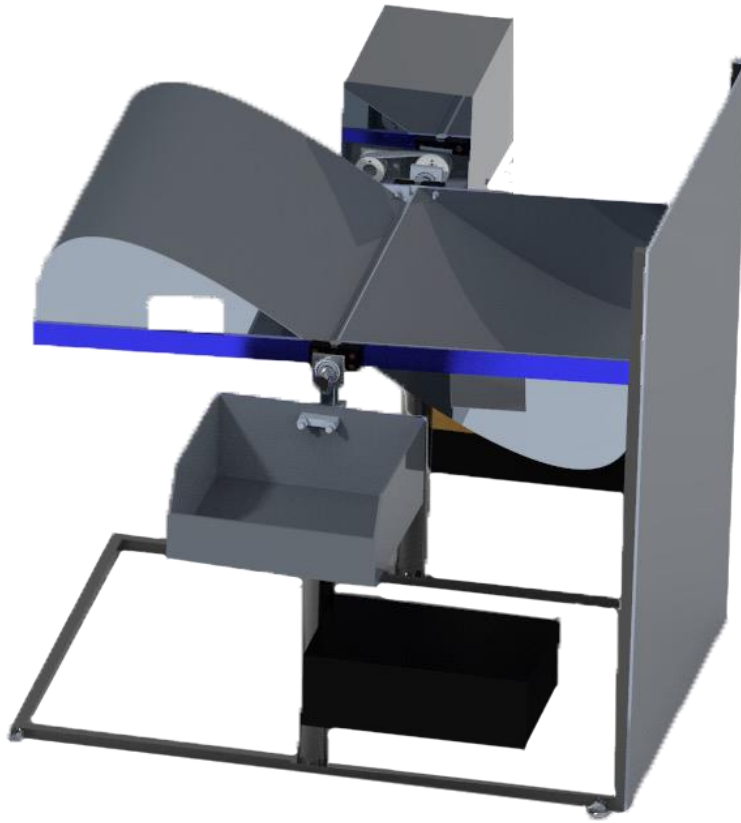

Figure 1: Trash Interceptor

Project Description

In 2019, Yamaha Motors created the Rightwaters Initiative to protect marine environments. Right now, it is estimated that for every three pounds of fish in the ocean, there is one pound of trash. By 2050, it is estimated to be a one-to-one ratio. It was determined that collecting trash in storm drains allows for trash collection early in the pollution cycle before the trash can reach larger bodies of water. This will allow trash to be collected before reaching rivers and oceans, therefore preserving marine environments. Yamaha wants to create a means of trash collection that is simple, yet effective and cost efficient.

Project Objective

The objective of this project is to implement an effective land-based trash interceptor that collects debris in storm drains to prevent trash from entering larger bodies of water.

Key Goals

A key goal for the trash interceptor is that it can scale to many different storm drains. Being scalable will result in the device being able to be used regardless of the water level in the storm drain, as well as different overall sizes of storm drains.

Another key goal is to design the trash interceptor so that it doesn't have to withstand major storms/hurricanes. However, the device will be able to withstand minor, everyday storms. This will allow the device to be expendable and easily replaced if damaged. Having the device be expendable will result in lower material costs, creating a more easily replaceable device as well as a more readily available product.

The final key goal of the trash interceptor is that the machine will be broken into modules of small subassemblies, which will result in easier deployment at the storm drain. Breaking the trash interceptor into modular subassemblies will result in lightweight modules, as well as being able to replace the specific module if damaged/broken.

Assumptions

Assumptions were made to control and narrow the scope of the project at hand. It is assumed that there will be a stable embankment where the device will be operating, meaning that there will be a stable foundation for the device. Additionally, it is assumed that the device will be installed by three skilled contractors that will be able to assemble the subassemblies without assistance from major machinery. Also, it is assumed that there will be a sustainable energy

source present at the site of deployment. It is also assumed the dumpster that the trash is collected in will be emptied regularly with the city trash schedule. One last assumption is that minor disturbances to the land area around where the device is deployed is permitted.

Component/Module Description

Since one of the key goals of the trash interceptor is having a modular style, there are multiple different modular pieces of the device. These modules are the basket, the base, the motor housing, the wiring/powering, and the basket bracket. The basket module is the double-sided basket that is rotating around a center shaft collecting trash. The base module is the support system as well as providing the device with buoyancy to rise to the water level. The motor housing module is in place to provide cover to the motor. The wiring/powering module contains the wiring to the motor and battery. Finally, the basket bracket allows the basket to be removed from the device in case of issues that could arise.

Basket Module

To assemble the basket, expanded metal(aluminum), 1/8" aluminum sheets, 1/4"x2"x48" aluminum plating, and aluminum rivets are used. The tear drop shaped basket sides are water jetted from the 1/8" aluminum sheet, and the drawing can be seen in appendix A, figure 22. The basket is comprised of 4 sides of aluminum plating. Two of the aluminum plates will be cut to 48.25", the other two will be cut to 30.75 inches. A U-shape will be cut out in the direct center of the longer two plates with a 1.5" diameter. This will be cut 1.5" into plate. Four holes will be drilled through the plate, so the bracket will be able to be bolted together to the outline. These holes will have a 0.26" diameter. Seven rivet holes on each side of the U-shape cut will be drilled through the longer two aluminum plates. The corners of each of the aluminum plating will be welded together. Once this is welded, the teardrop shapes will be riveted to the inside of the

aluminum outline. The expanded metal is then shaped and welded to the shape of the teardrop to make two baskets. This assembly and exploded view can be seen in figure 2 and 3, respectively.

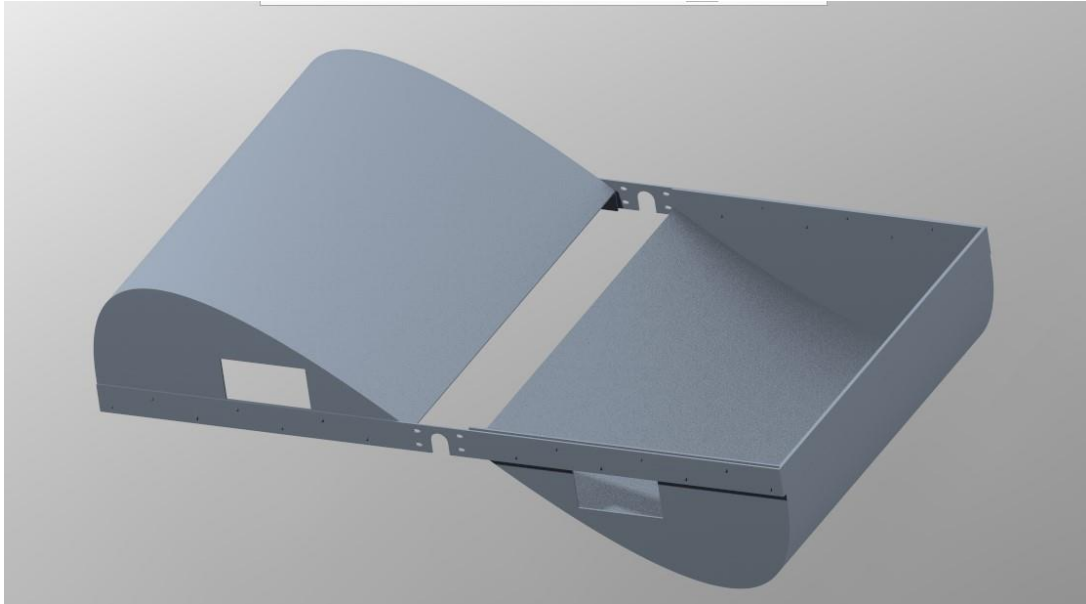

Figure 2: Full Basket Module

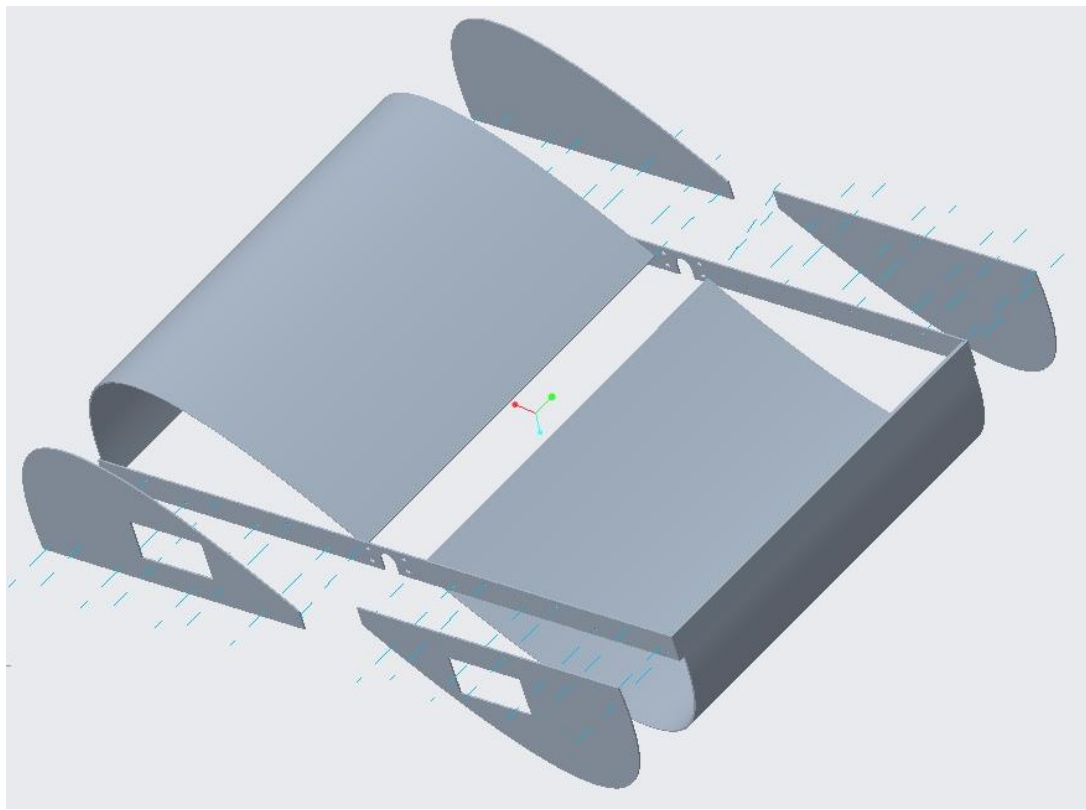

Figure 3: Exploded View of Full Basket

Base Module

The base consists of four, one inch by one inch steel bars. The length of the base is 48 inches, while the width of the base is 36 inches. One 48-inch bar will be welded together with a 36-inch bar to create an L-shape with a 90-degree corner. Two L-shapes will be made to create a rectangular base. The two corners that are not welded together will be connected via an L-bracket on the inside of the corner. The dimensions of the L-brackets are 5"x5". Six, 2-inch, 1/4-20 bolts will be used for each bracket. The vertical rectangular tubes that are seen in figure 4 are 30 inches in length and are 1.25"x1.25". On one side of each rectangular tube, there is a 0.5" slot cut 25.25 inches down from the top. These tubes are supported by gussets that are 4"x4". The gussets are fastened to the rectangular base via 2 inch, 1/4-20 bolts. The vertical part of the gusset is attached to the rectangular tube via 3 inch, 1/4-20 bolts and fastened with a nut and washer. All the holes drilled through the base bars and the vertical rectangular tubes are 5/16 of an inch. A fully assembled base and an exploded view of the base can be seen in figure 4 and 5, respectively.

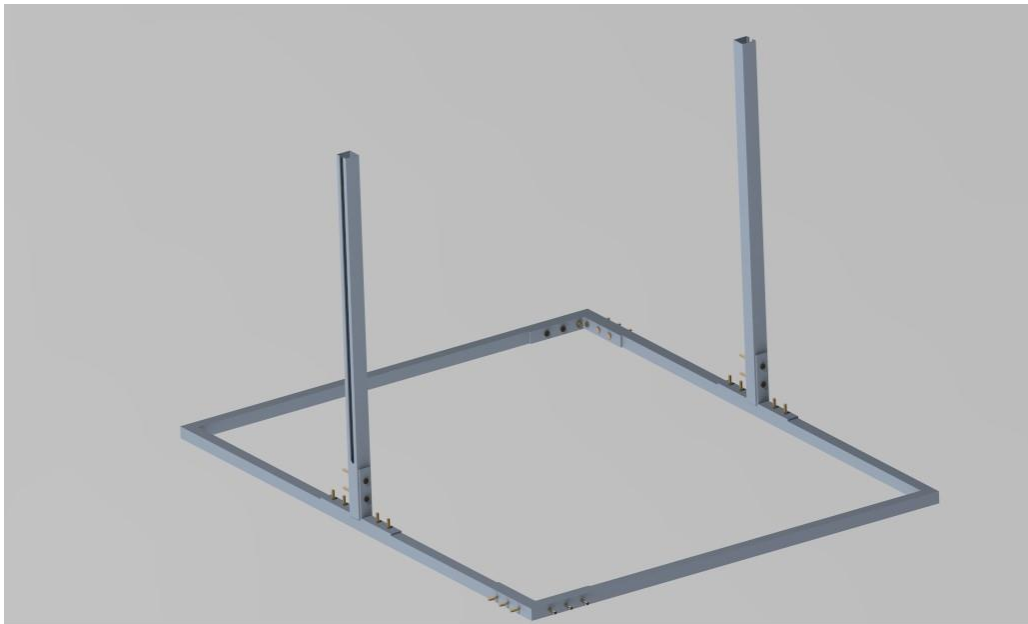

Figure 4: Full Base Module

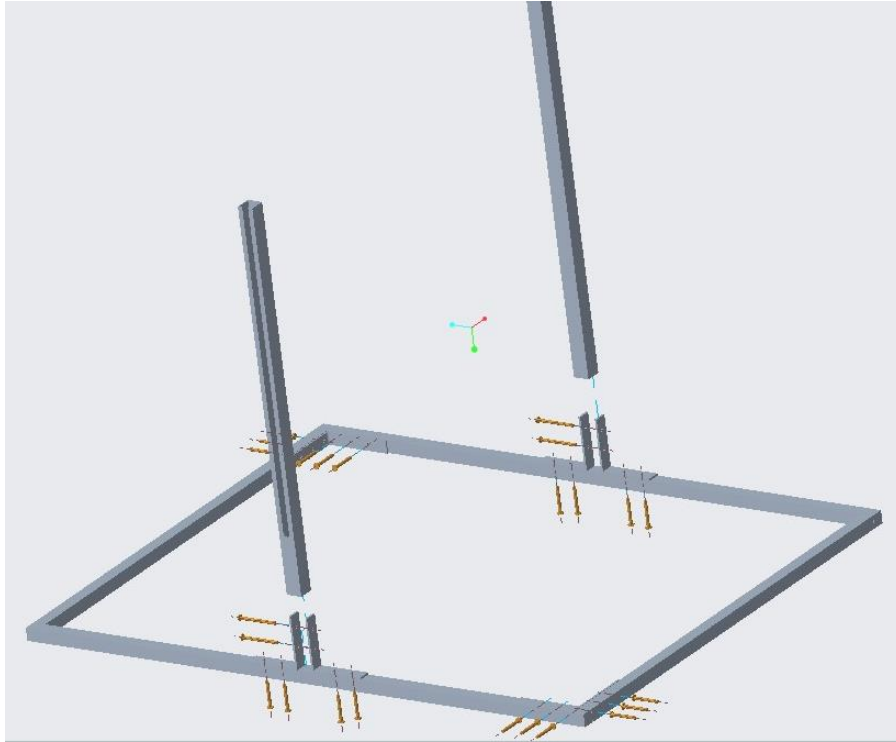

Figure 5: Full Base Module, Exploded View

Motor Housing Module

To assemble the motor housing, a 0.05” thick aluminum sheet, 1/4-20 bolts, a 0.19”x12”x24” aluminum sheet, and four, 3/8”x2”x2”, 90-degree aluminum will be used. The 0.05” thick aluminum sheet will be water jetted to the dimensions shown in appendix A, figure 24. Once the piece is water jetted, all of the flaps are bent in, so the corner is as close to 90 degrees as possible. Four different pieces of the 90-degree aluminum will be used to create the motor housing bottom. Two pieces will be cut to 13”, while the other two are cut to 12”. At the ends of all of the pieces of 90-degree aluminum, it will be cut at a 45-degree angle, so the pieces can mesh together to create a rectangle. These edges will be welded together to ensure a strong connection. The 0.19” thick aluminum sheet will act as the base. It will be cut to 11.25”x12.25”. With three evenly spaced holes along the edge. These holes will match with the holes on the 90-degree aluminum. These pieces will be fastened together via 1/4-20 bolts. Slots will also be cut

out, so the motor has a little bit of play to determine the tension of the belt. The distance between the rotating shaft and the motor shaft is 6.25 inches. One the bottom of the motor housing as been assembled, the top of the motor housing that is water jetted will be bolted on to the bottom, so the motor will be encapsulated. A gusset will be used to add additional support to the motor housing that is attached to the concentric pipe. U-bolts will be used to attach the housing to the concentric pipe. The gusset will just add additional support to the motor.



Figure 6: Motor Housing Assembled

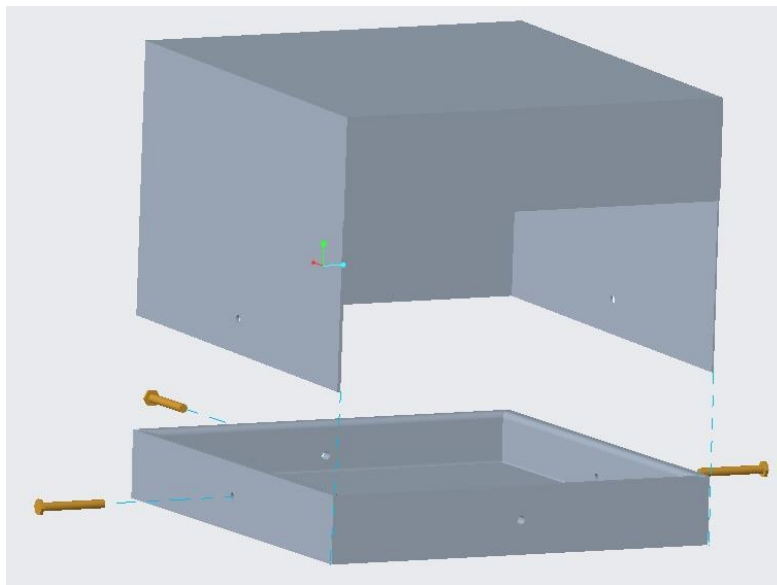

Figure 7: Motor Housing Exploded

Wiring/Powering Module

The wiring module consists of a 12-volt, 20 Ah DC battery, a 12-volt DC gearmotor, a Dart Controls 65 series DC PWM speed controller, a 10 Amp fuse with a fuse holder, and a simple on-off switch. After all of the wiring is connected and secure, the user is able to flip the switch and the motor will begin to rotate. The speed the motor is rotating can then be controlled using the speed controller dial. Shown below is a wiring diagram that the device will follow in order to provide the motor with the correct voltage, as well as being able to control the speed of the motor.

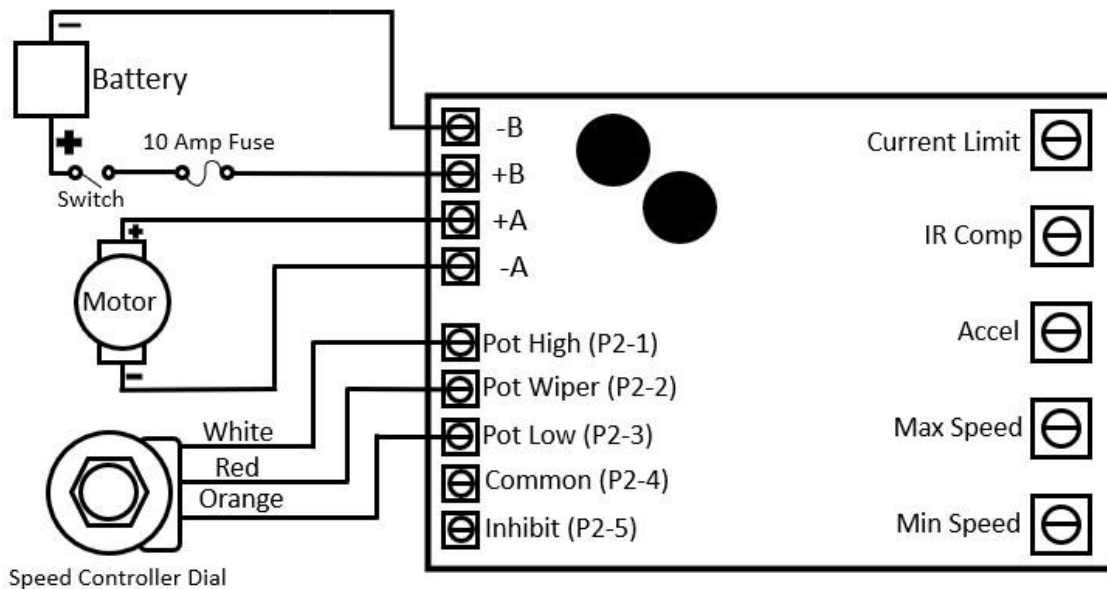

Figure 8: Wiring Diagram

The black wire coming out of the top left pin is connected to the negative end of the battery. The yellow wire is the fuse which is attached to the switch which is attached to the positive end of the battery. The white and black wires are coming out of the motor. The white, red, and orange wires are connected to the speed potentiometer. The connected assembly can be seen below in figure 9.

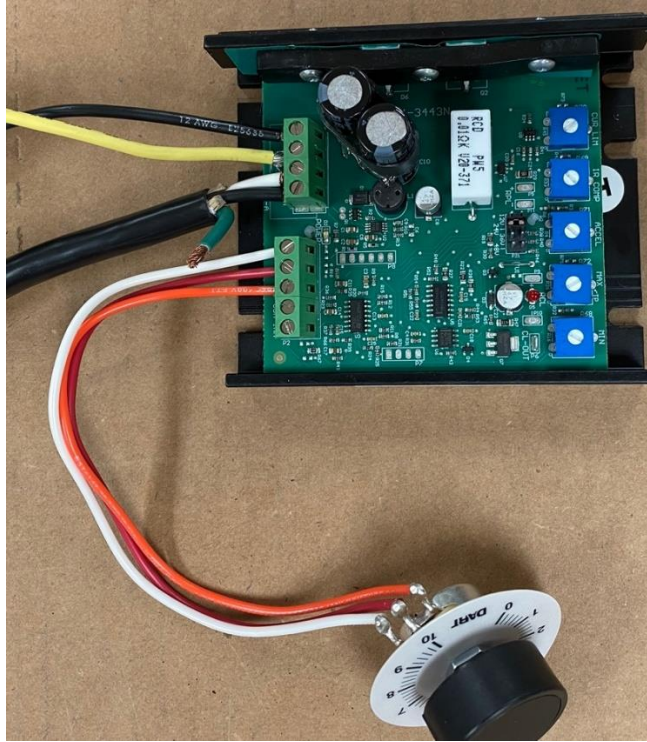

Figure 9: Assembled Wiring Diagram

The motor shaft has a 5/8” bushing with a 3/16” keyway, which is then mated to a 1” thick timing pulley. This will allow the transmission of power from the motor to the rotating shaft. The belt used is a 1” thick, 21 inches long, with 56 teeth. This will match with the bushing and pulley that is placed onto the rotating shaft to produce the transmission of power that is needed.

Basket Bracket/Bearing Housing Module

To allow the basket to have a modular style, the assembly had to take a different approach. A bracket needed to be created using an aluminum sheet with dimensions 1”x8”x8”. Two brackets that are 4 inches long by 2 inches wide are made of this aluminum sheet. The same U-shape is machined out with a diameter of 1.25”, 1.5” into the bracket, so it can cup the shaft. There are also four 1/4-20 tapped holes that will line up with the basket outline. A hole is drilled through the top of the bracket that goes directly through the U-shape to go through a hole in the

shaft as well, to lock in the baskets to the shaft. The bracket is fastened to the basket outline via 1/4-20 bolts. This same aluminum sheet will be used to create the bearing housings.

The bearing housings are circular with a square piece coming out of the bottom. The outer diameter of the bearing housing is 2.75" with a wall thickness of 0.75". Through the square piece there is a hole that a 1/4-20 bolt will go through. Through the bottom of the square piece, a hole is machined out, so a 3/4 concentric tube can fit into the hole. A hole is also drilled through the concentric pipe, so the hole on the bearing housing matches with the hole on the concentric pipe. A 1/4-20 bolt is then used to fasten the two together. Two corrosive resistant ball bearings that fit a 1.25" shaft are used. The rotating center shaft that the baskets are revolving around has one end lathed to fit into a 1-inch bushing. This bushing is then mated with a gear pulley that will have a belt around it. This will allow power transmission from the motor to the baskets.

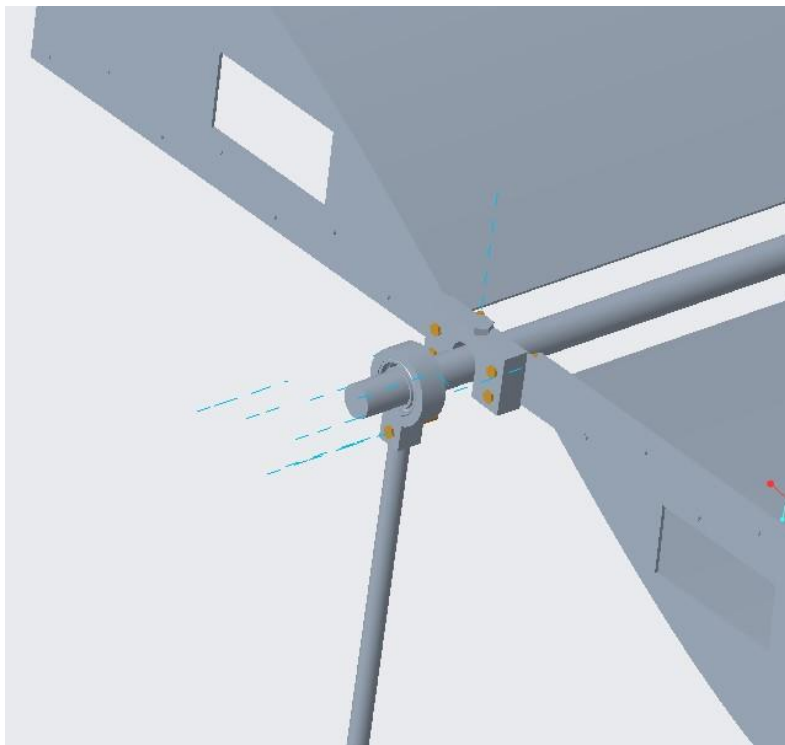

Figure 10: Bracket and Bearing Housing Assembled

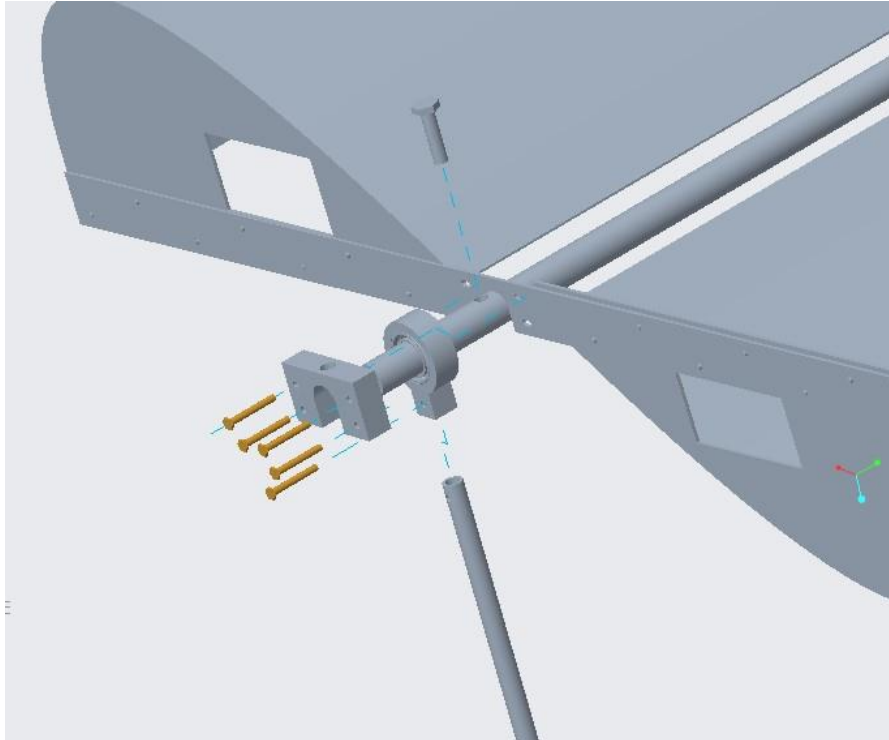

Figure 11: Bracket and Bearing Housing Exploded

A temporary reservoir is added to the concentric pipe shown above. The reservoir is a mesh type basket with a length of 16 inches, a width of 15 inches, and a depth of 7 inches. This reservoir is attached to the concentric tubes via two U-bolts that are meant for a 3/4-inch pipe. On the inside of the reservoir the bolts go through a 6"x6" sheet of UHMW Polyethylene. This will serve as a type of washer to not put stress onto the mesh of the basket. A photo of the basket can be seen below in figure 12.



Figure 12: Reservoir Basket with UHMW

Flotation with Concentric Pipe Module

To make the device rise and lower with the level and depth of the water, a flotation module must be created. To achieve raising and lowering, buoys will be attached to the inner concentric pipe leg that is attached to the rotating baskets. This will allow for the module with the baskets and motor housing to raise with the baskets to continue to transmit power. A thin aluminum plate that is 5"x2"x0.25" is welded onto the pipe four inches up from the bottom. Off of this plate, another aluminum plate with dimensions 12"x2"x0.25" will be attached perpendicular to the plate that is attached to the concentric pipe. This plate will be what the buoy is attached to. The buoys that are used are three-gallon jugs that will contain air. If needed, they will be able to be ballasted, so that the device does not raise too much. To ensure that the inner concentric pipes do not raise too high and exit the outer rectangular tube, a safety wire will be attached around the plate coming off of the inner concentric pipe and the gusset attaching the rectangular tube. The jugs will be attached to the aluminum plate via rivets with rubber grommets. This will ensure that no unwanted water will be entering the jugs. An assembled view with the concentric pipe and an exploded view of the assembly of the flotation module can be seen below in figure 13 and 14, respectively.

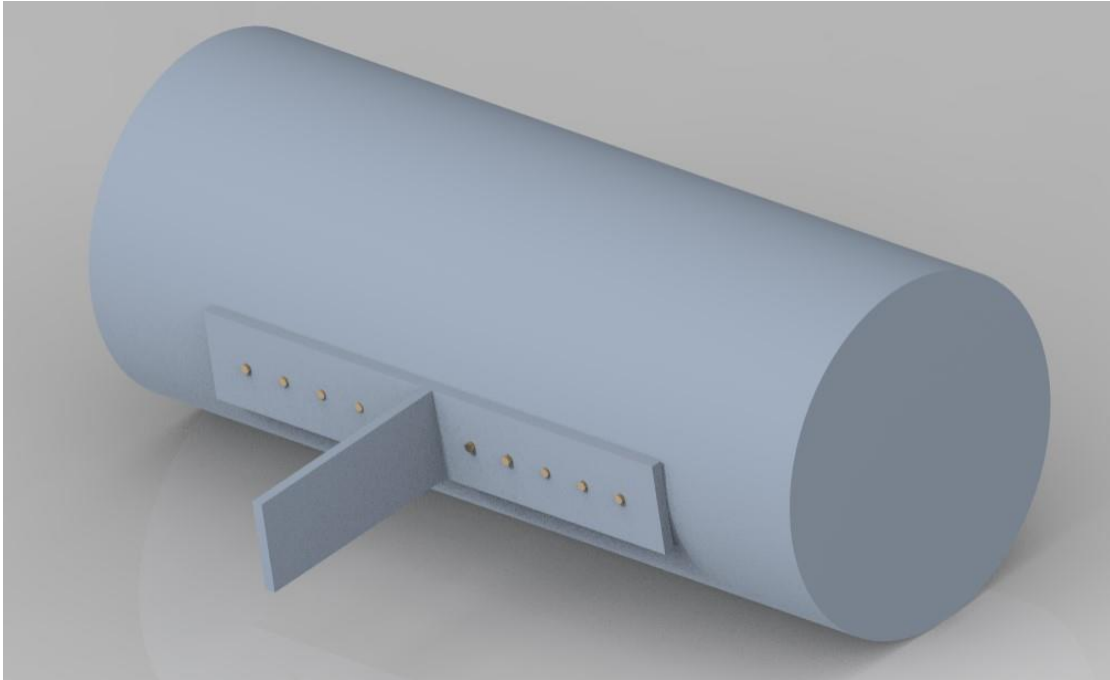

Figure 13: Assembled Buoy Connection

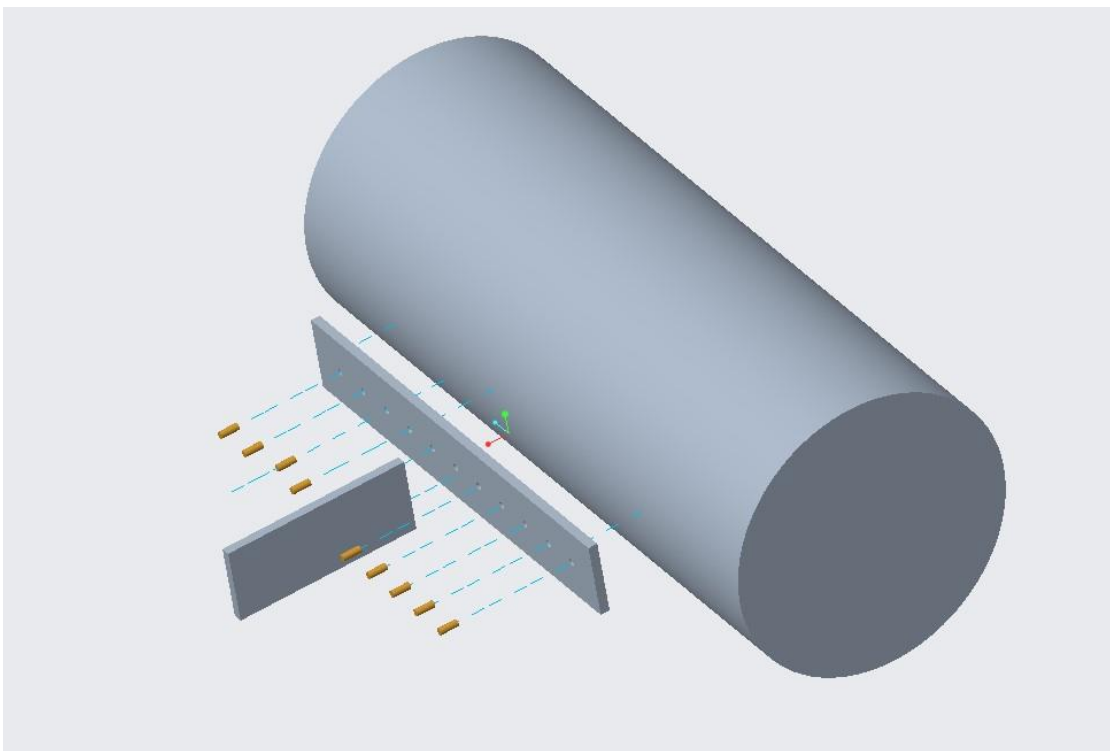

Figure 14: Exploded Buoy Connection

Integration

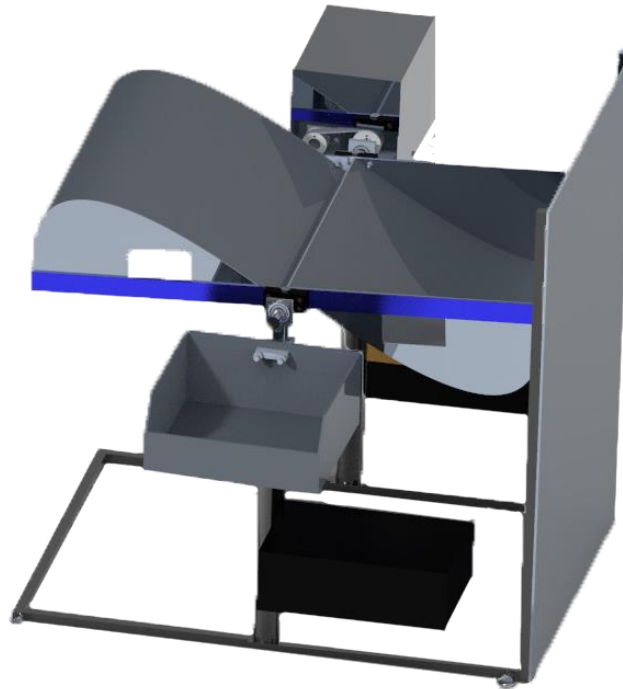

Figure 15: Full Trash Interceptor with all modules

Once all of the individual modules have been assembled, the final product can be assembled. The base will be placed onto the ground first and everything else will be added to the base. The basket will then be taken, and the concentric tubes connected to the basket will be placed inside the rectangular tubes that are connected to the base. To ensure that it is properly attached, the piece of the shaft that the floating buoys are attached to should follow the slot cut out of the rectangular tube. Once this is attached, the motor housing can then be attached to the concentric pipe to give the rotating baskets power. The motor is in the motor housing when attached to the concentric pipes. The belt is then placed onto both pulleys to ensure that the belt has enough tension to transmit power. The brackets are attached to ensure that the basket rotates as the shaft rotates. The user is then able to make sure that the device is moving at the correct RPM. This can be done by playing with the speed controller dial. After the subassemblies have

been created, the only thing that is left to do is putting all of the modules together. Once this is done, the device is ready to go and is ready to collect trash.

Operation

Once the device has been fully assembled in the storm drain, a collection of solar panels will be set up in order to gain the necessary amount of charge to power the device. The edge of the device containing the temporary reservoir basket will be placed onto the edge of the storm drain that is closest to the dumpster. This will allow for a conveyor belt to be able to take the trash from the temporary reservoir and place it into the dumpster. An expandable floating boom will be placed on the front corner that is not along the bank. It will be placed on an angle connecting the front edge on the motor side to the opposite side of the storm drain. The trash will then be guided into the device, allowing the rotating baskets to remove the trash from the storm drain. All of the wiring will then be inspected to ensure that it is required correctly. The user will want to set the speed dial to 2.5 to ensure that the device is rotating at 6 revolutions per minute. When water is flowing through the storm drain, the device will begin to rotate and remove trash from the storm drain. The battery will be able to be charged autonomously due to the solar panels. The trash that is transported to the dumpster will be emptied with the regular trash schedule that the city has in place.

If the trash interceptor is being monitored and it is determined that there is a better place to deploy the device, contractors will be able to disassemble the device and move it to another location. The device will only be running while there is water flowing through the storm drain, meaning that it will most likely be running only after a significant rainstorm.

Troubleshooting

If there are issues while operating the trash interceptor, there are a few aspects to check for that may be causing the problem. First, it would be a good idea to check the wiring between the battery, the motor, and the motor speed controller to ensure that everything is wired properly by referring to the wiring diagram shown in the Component/Module Section. One thing to check in particular about the wiring is that the fuse has not been blown. If this is the case, one can simply open the fuse holder and insert a new 10 Amp fuse. Along these similar lines, it is essential that the solar panels are properly connected to the battery to ensure that the battery will remain charged to power the device. Another item that may be causing errors is the timing belt and the timing belt pulleys. It is very important to ensure that the motor shaft and the rotating middle shaft are level with one another, so that the timing belt is rotating properly. If this is not the case, one can tighten the bolts between the gusset and the inner concentric pipes to ensure it is properly placed. As well as tightening these bolts, one can ensure that the bolts connecting the motor and the motor housing are securely tightened, ensuring correct spacing between the two pulleys. Another possible issue that could cause the device to stop operating is a build up of dirt or algae in both the rectangular outer concentric tubes, as well as the bearings. To do this, the contractor will be able to take apart these small subassemblies to clean and rid these parts of dirt and algae.

Appendix A – Machine Drawings

The following images are drawings brought to the FAMU-FSU College of Engineering Machine shop to be machined.

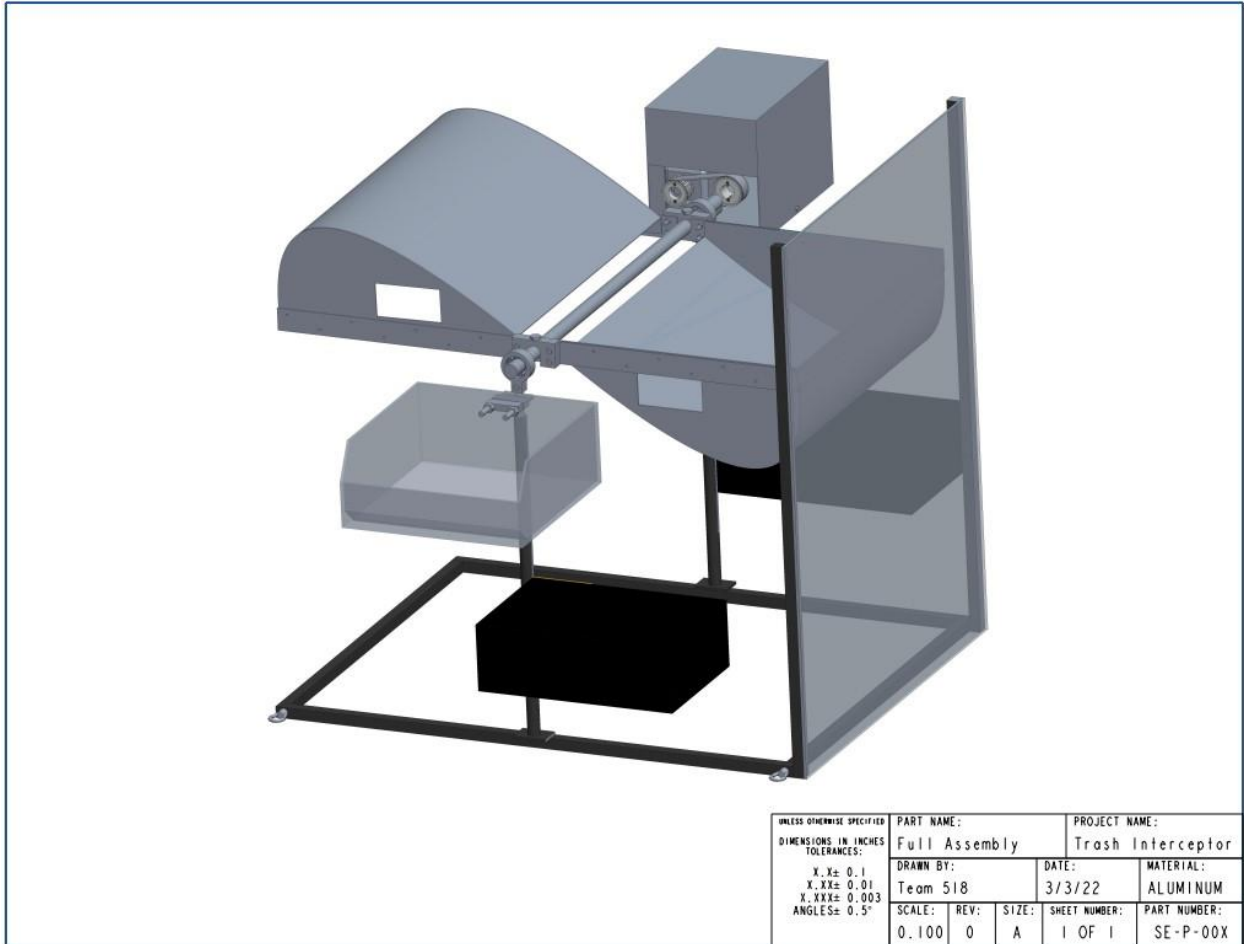

Figure 16: Full Assembly Drawing

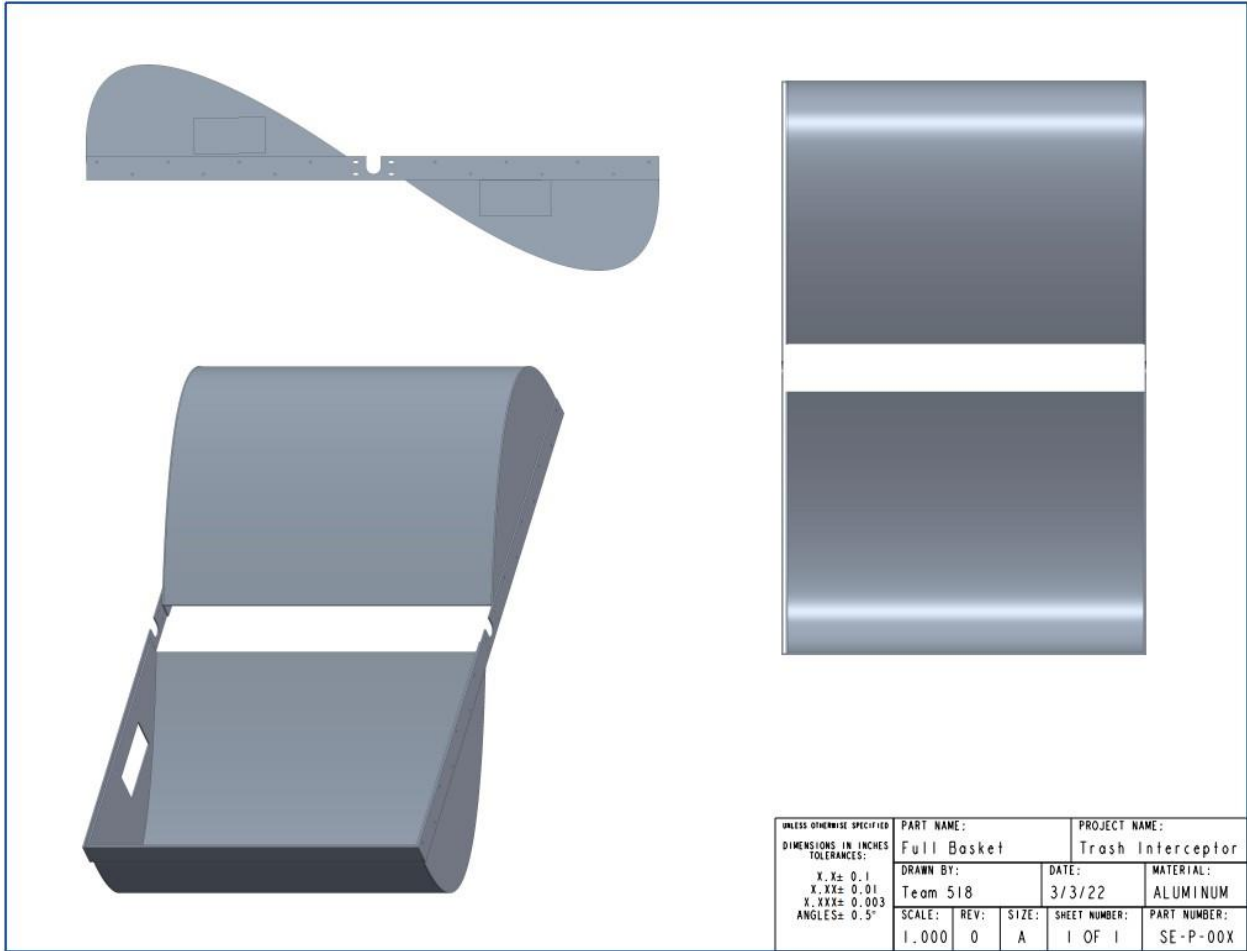

Figure 17: Full Basket Assembly

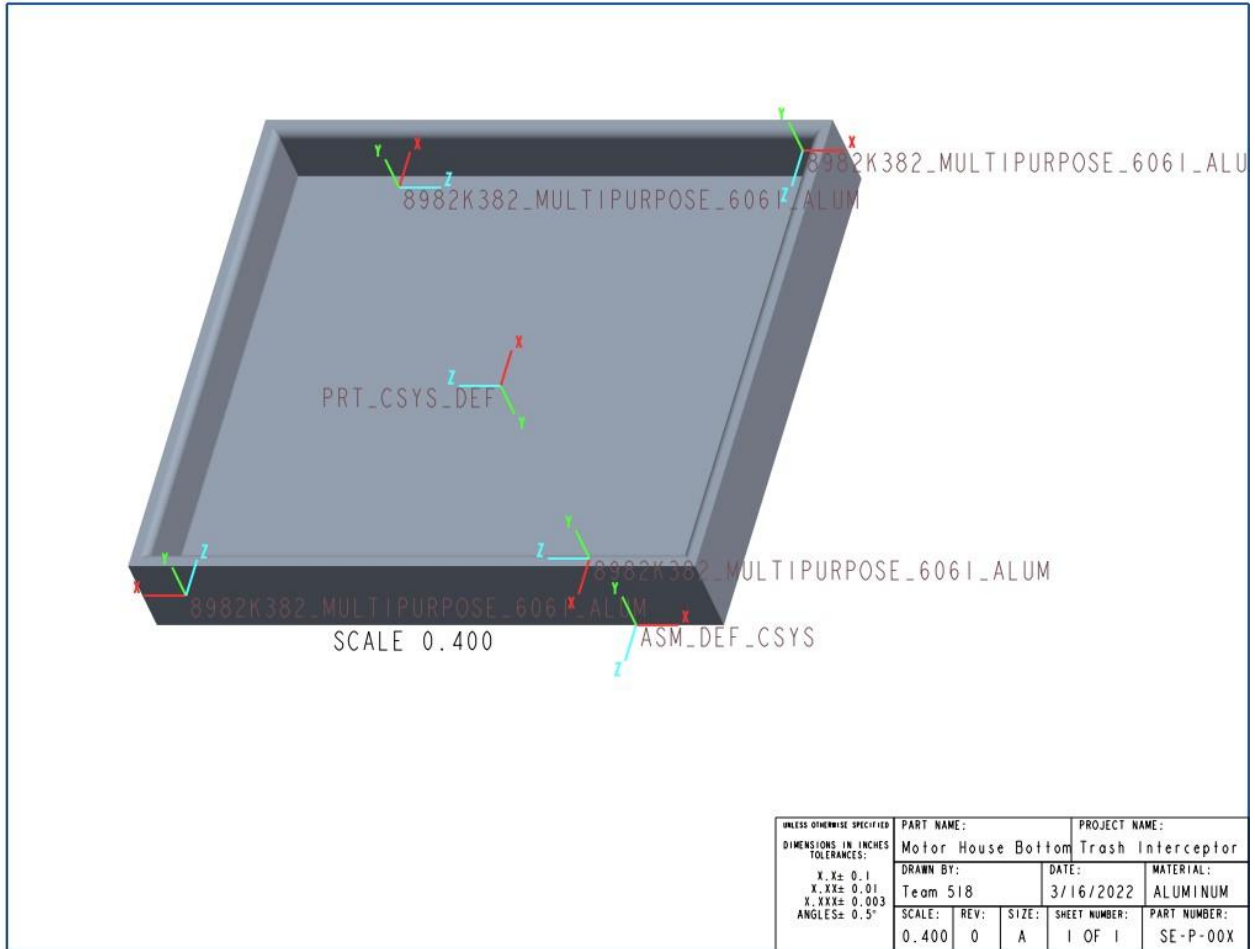

Figure 18: Assembled Motor Housing Bottom

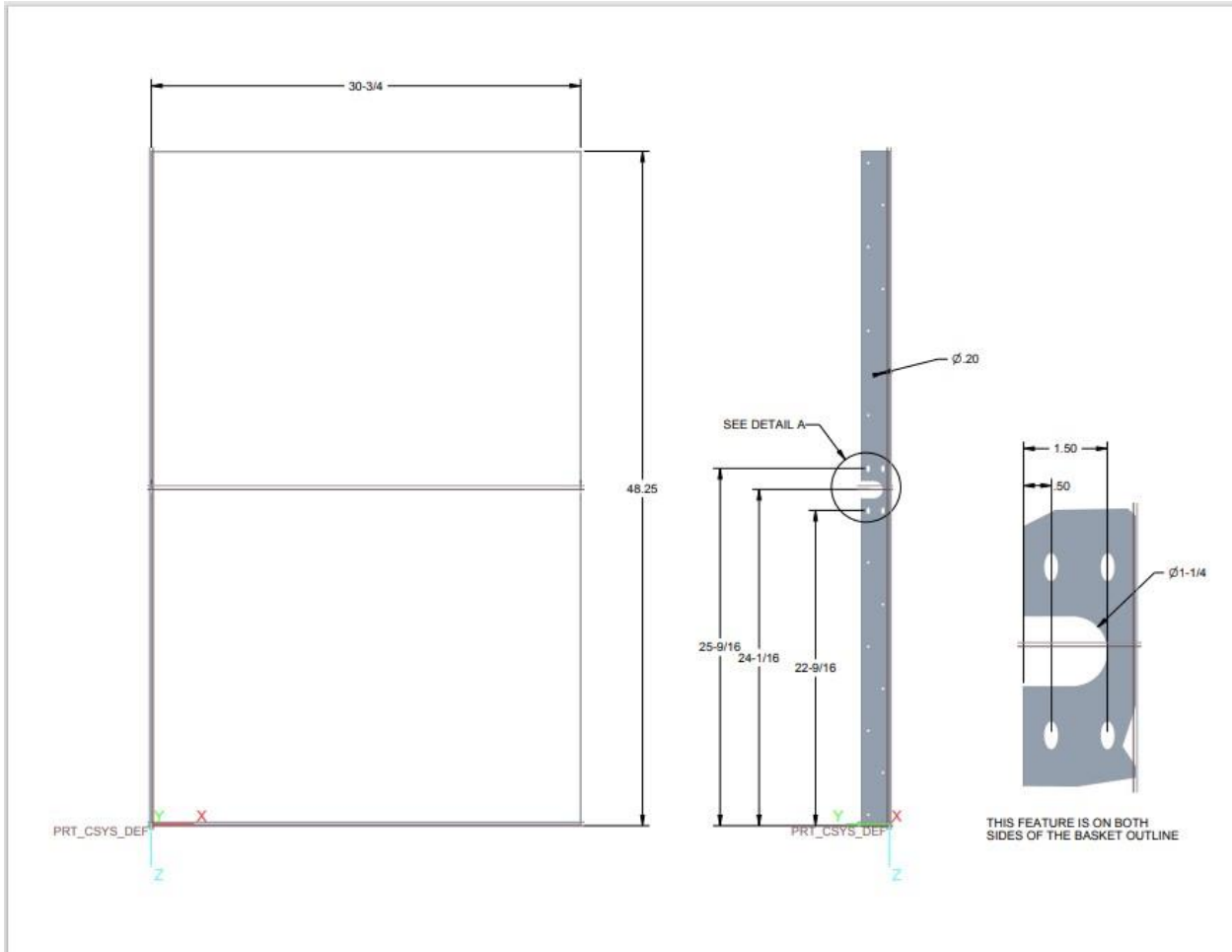

Figure 19: Basket Support/Outline

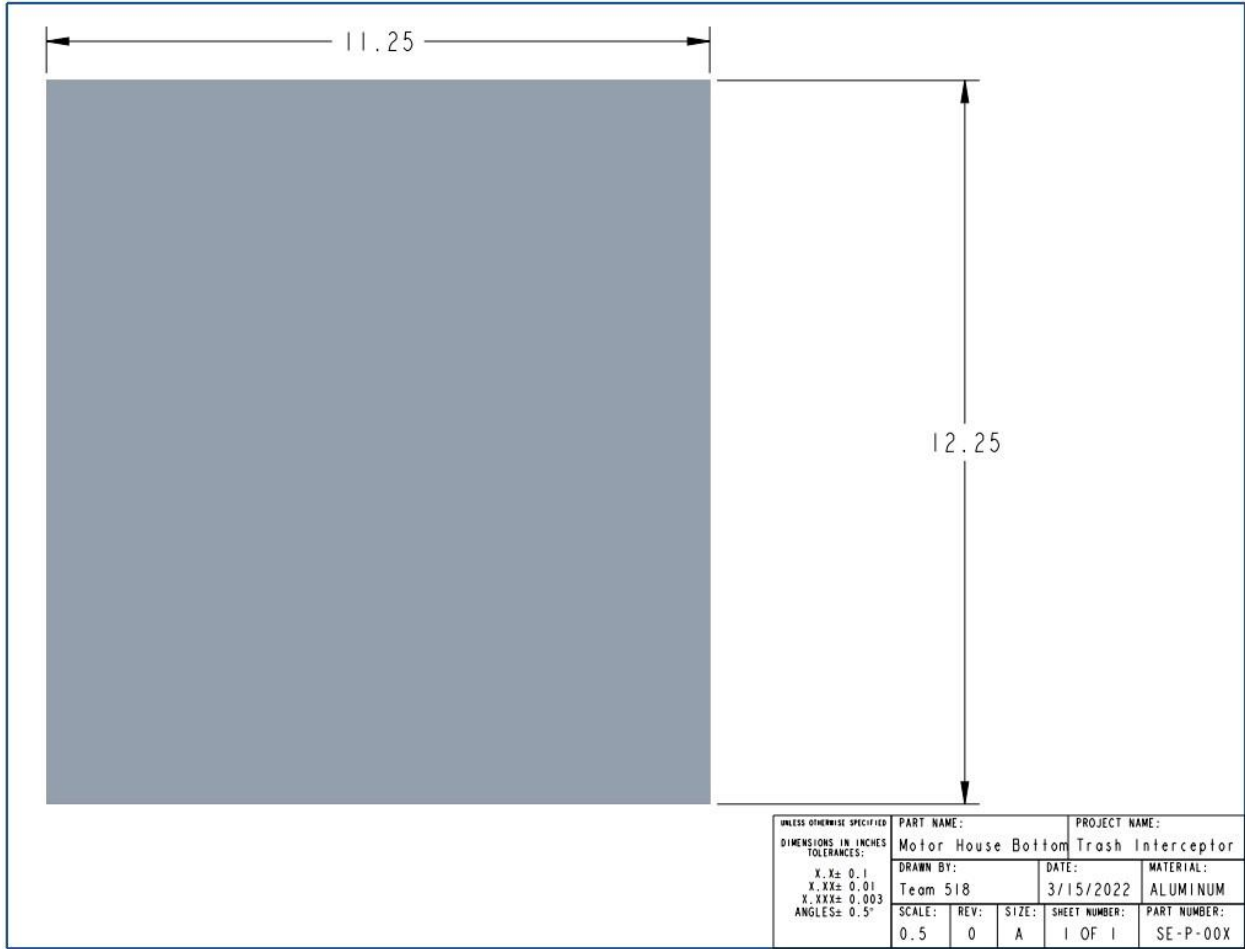

Figure 20: Motor Housing Bottom

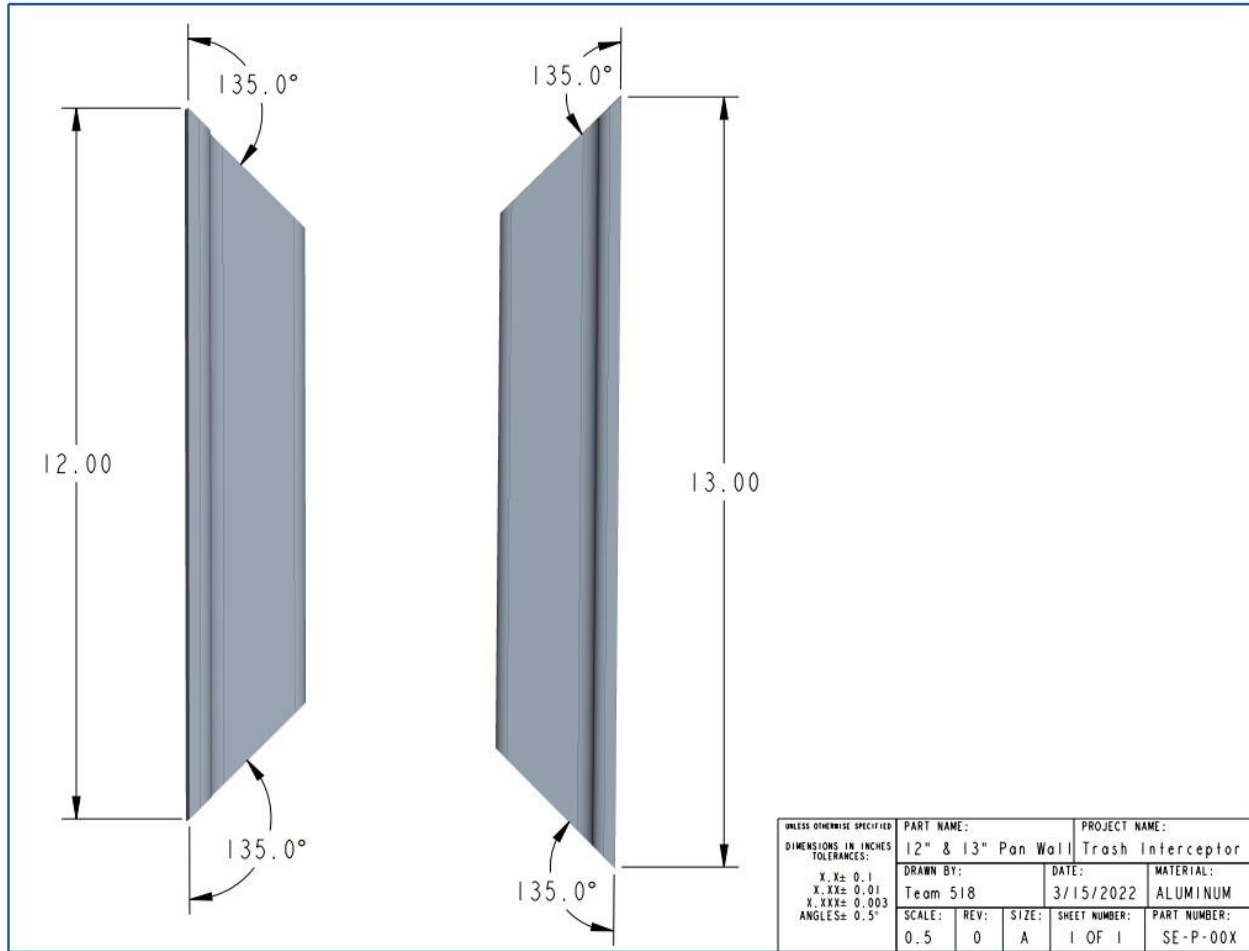

Figure 21: Motor Housing Bottom Walls

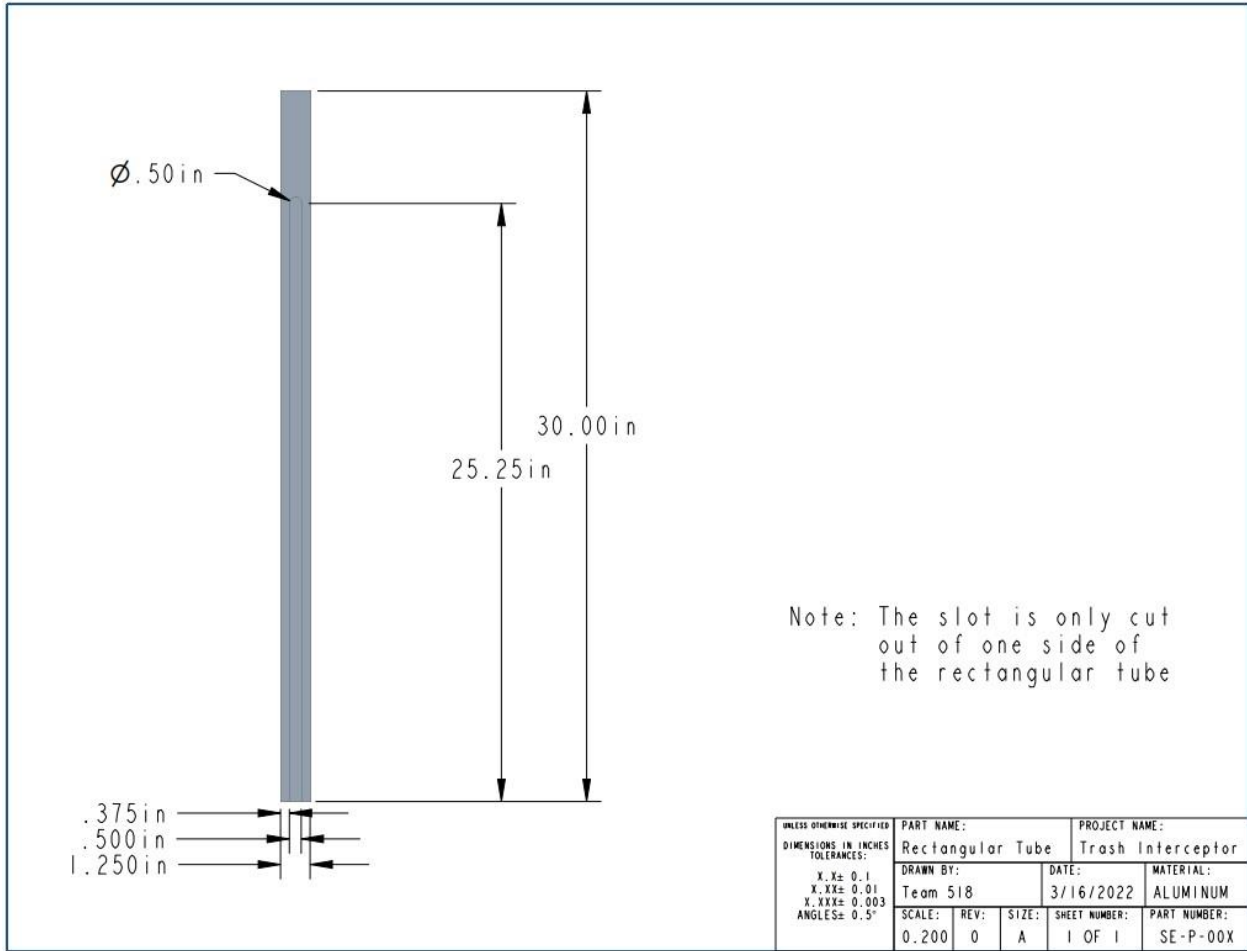

Figure 22: Rectangular Tubes

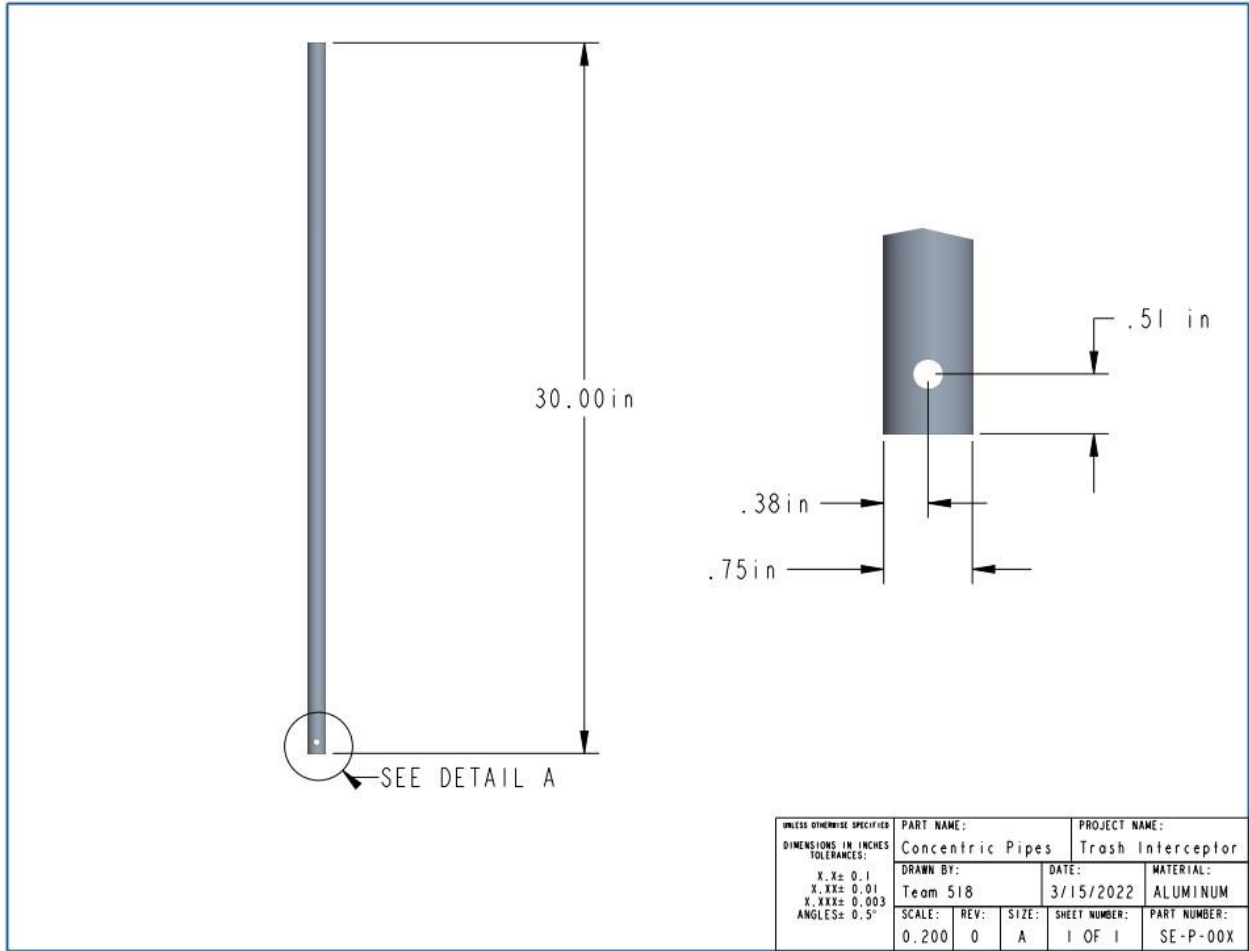

Figure 23: Inner Concentric Pipes

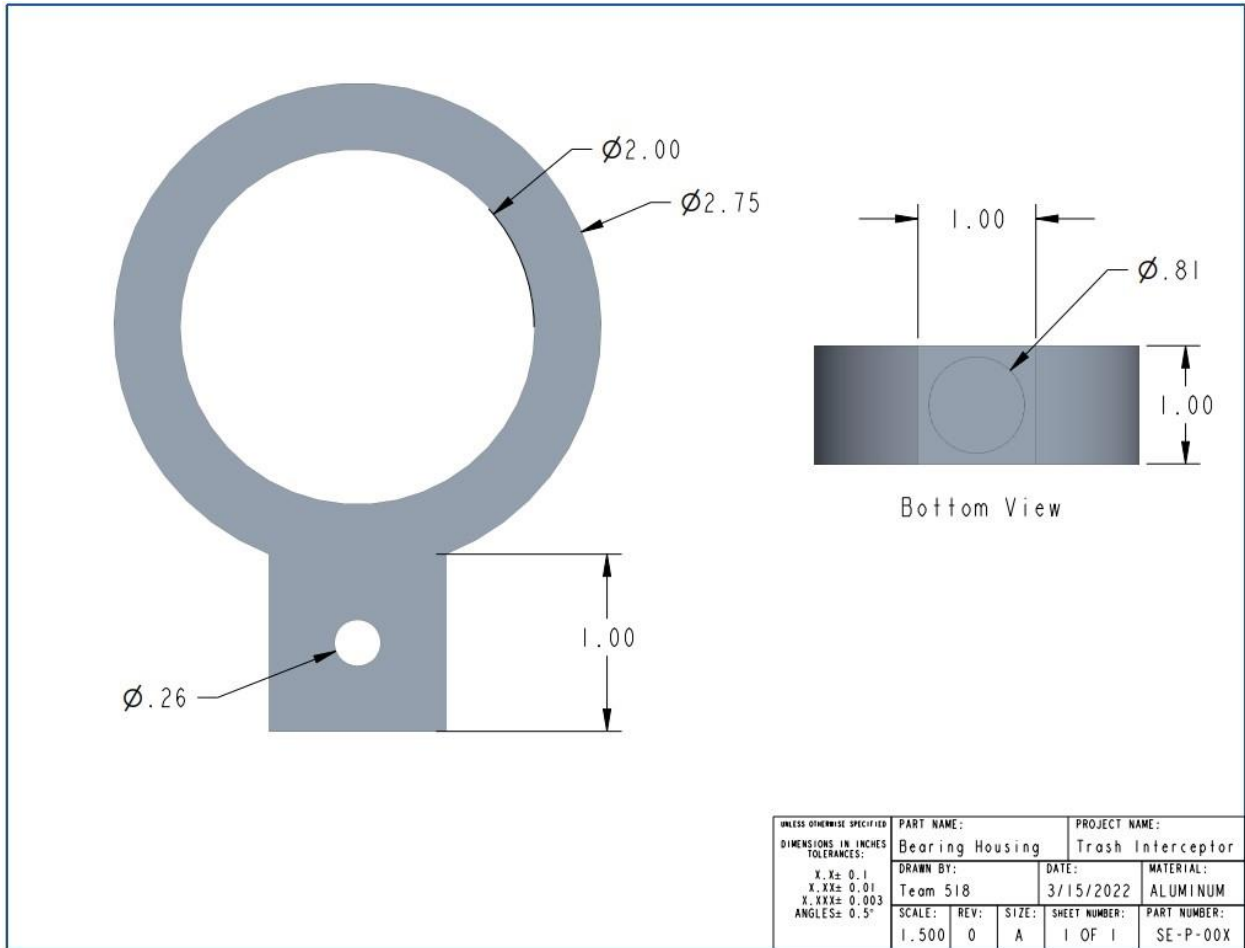

Figure 24: Bearing Housing

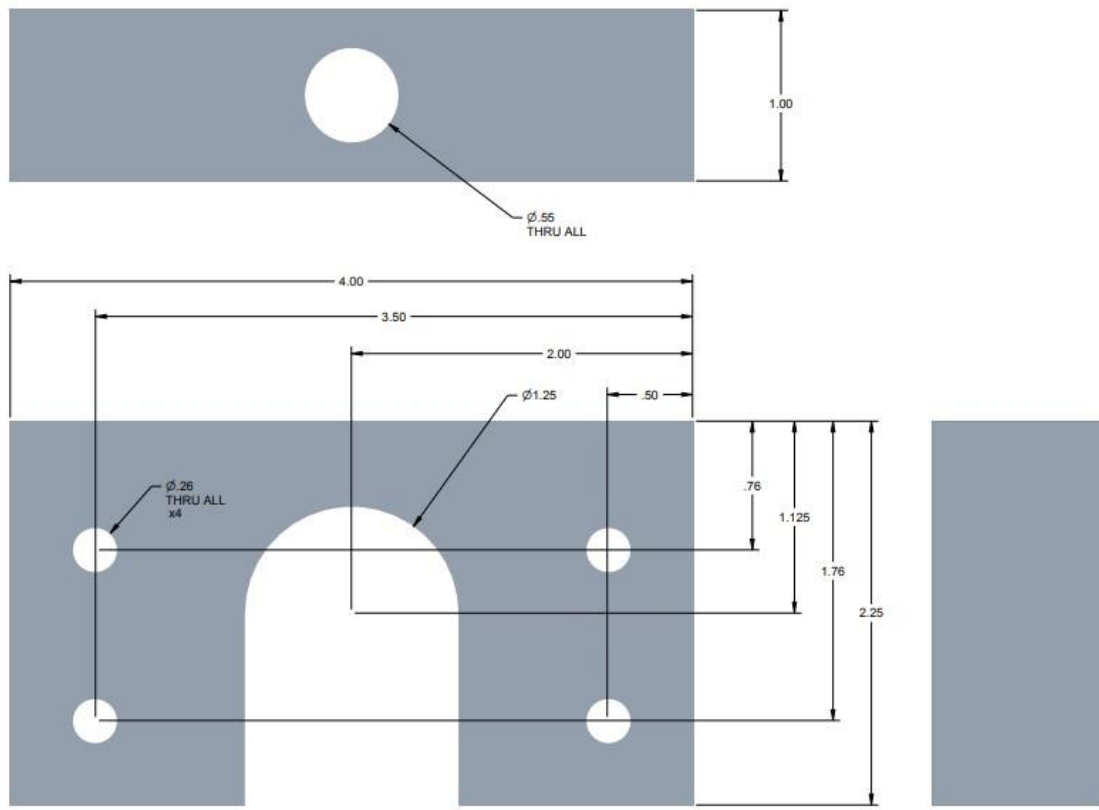

Figure 25: Basket Bracket

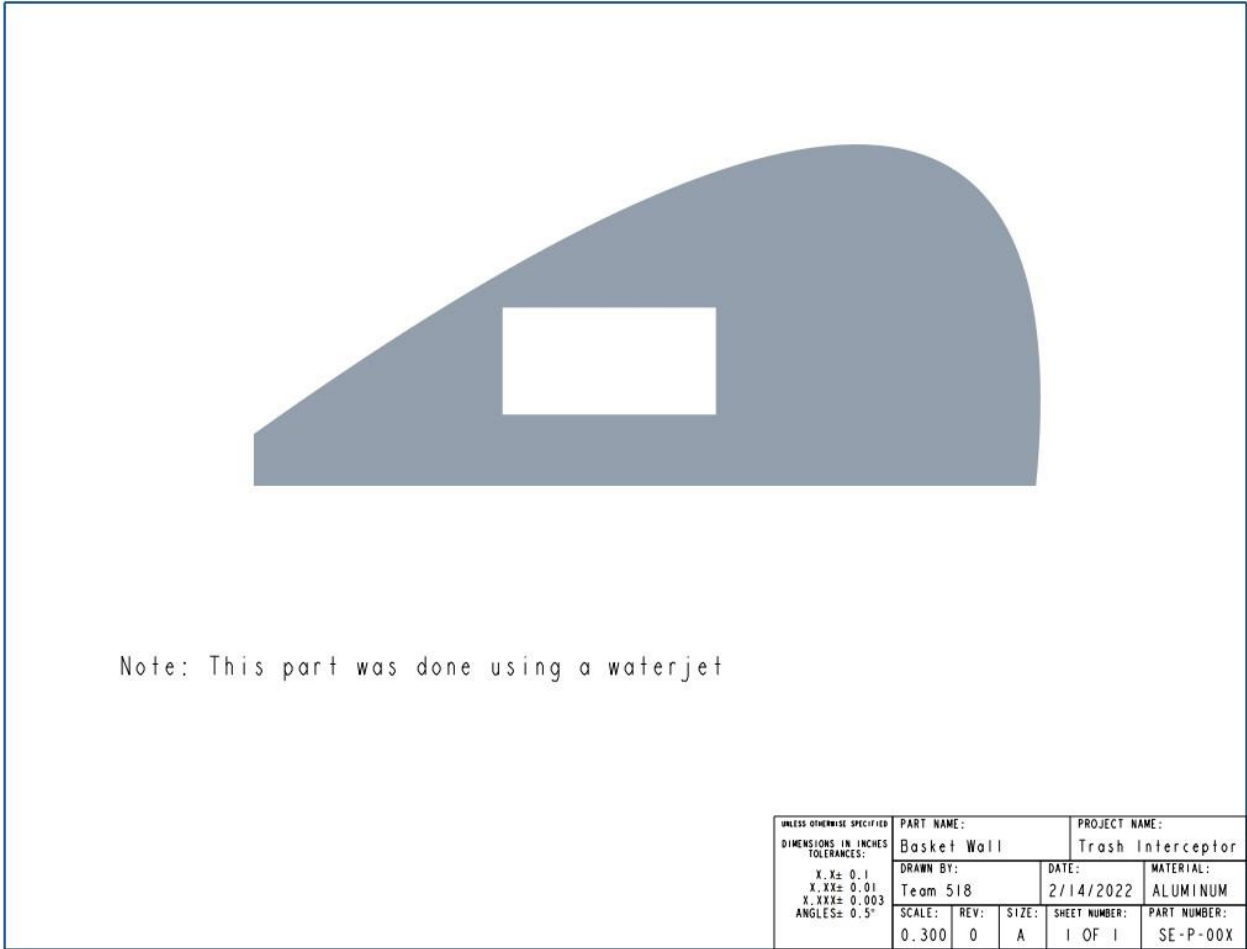
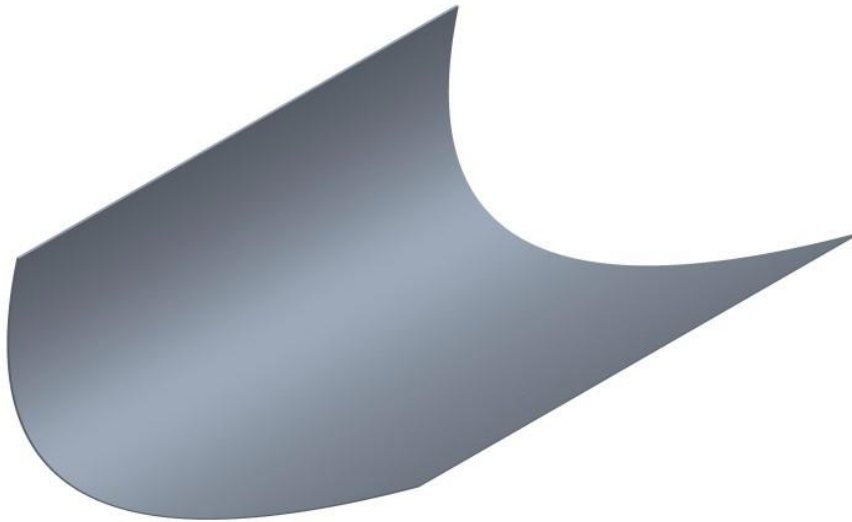

Figure 26: Basket Wall



Note: This is rounded along the basket wall
and welded to the basket wall

Note: Once fitted to the basket wall
cut off the rest

UNLESS OTHERWISE SPECIFIED DIMENSIONS IN INCHES TOLERANCES: X.X± 0.1 X.XX± 0.01 X.XXX± 0.003 ANGLES± 0.5°	PART NAME:		PROJECT NAME:	
	Basket Mesh		Trash Interceptor	
	DRAWN BY:		DATE:	MATERIAL:
	Team 518		2/14/2022	ALUMINUM
SCALE:	REV:	SIZE:	SHEET NUMBER:	PART NUMBER:
0.200	0	A	1 OF 1	SE-P-00X

Figure 27: Basket Mesh

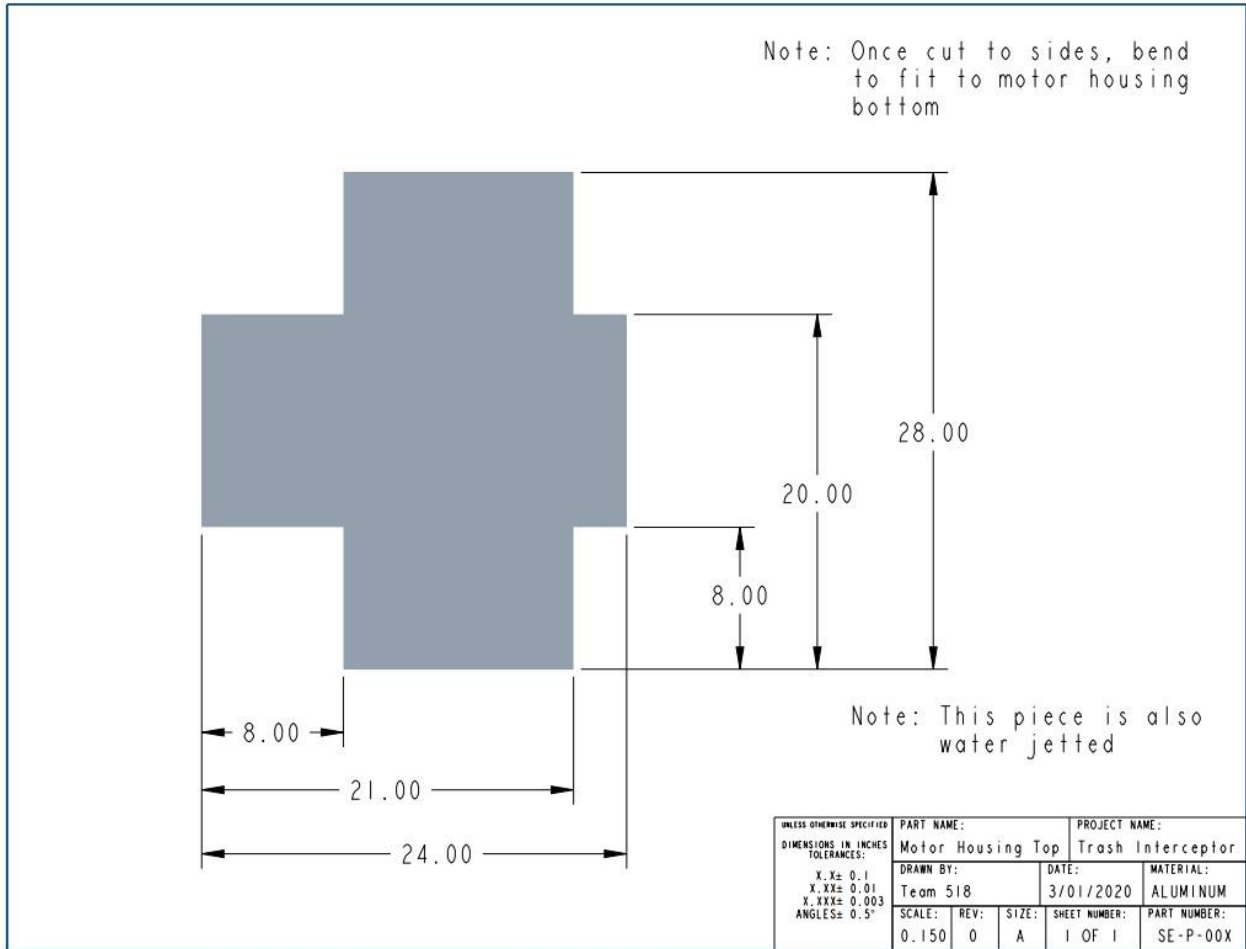

Figure 28: Motor Housing Top

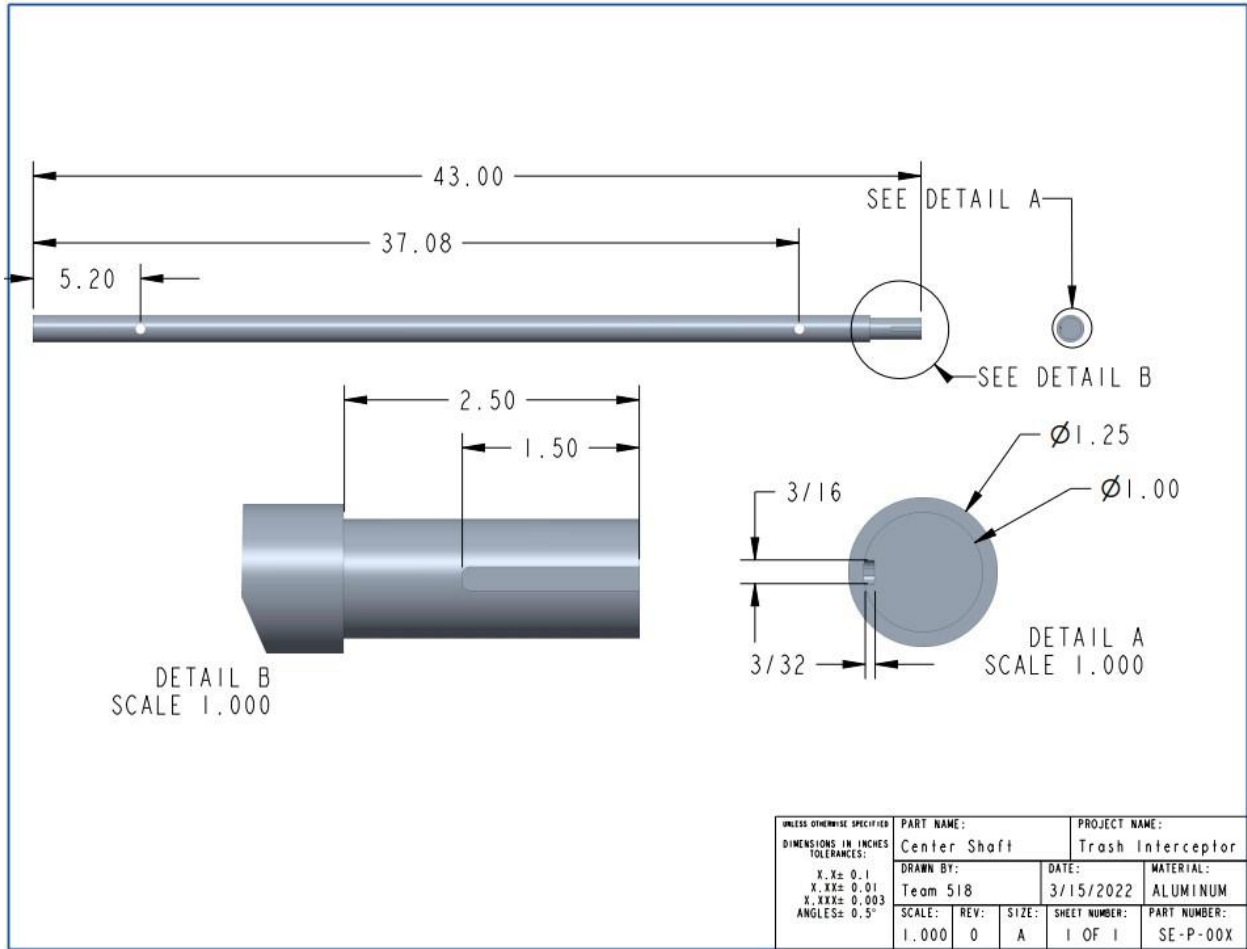

Figure 29: Center Shaft

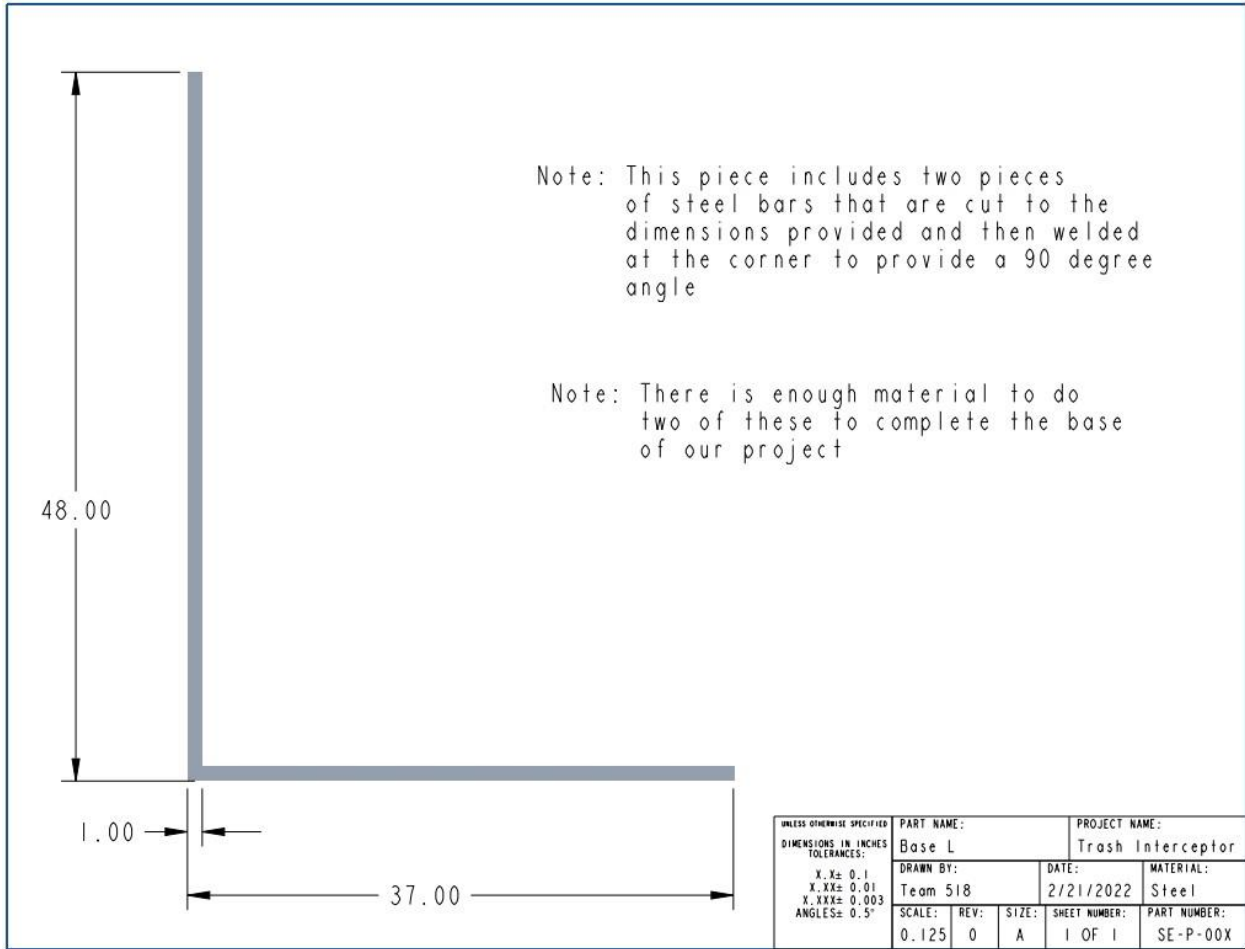

Figure 30: Base L, two of these make up the base

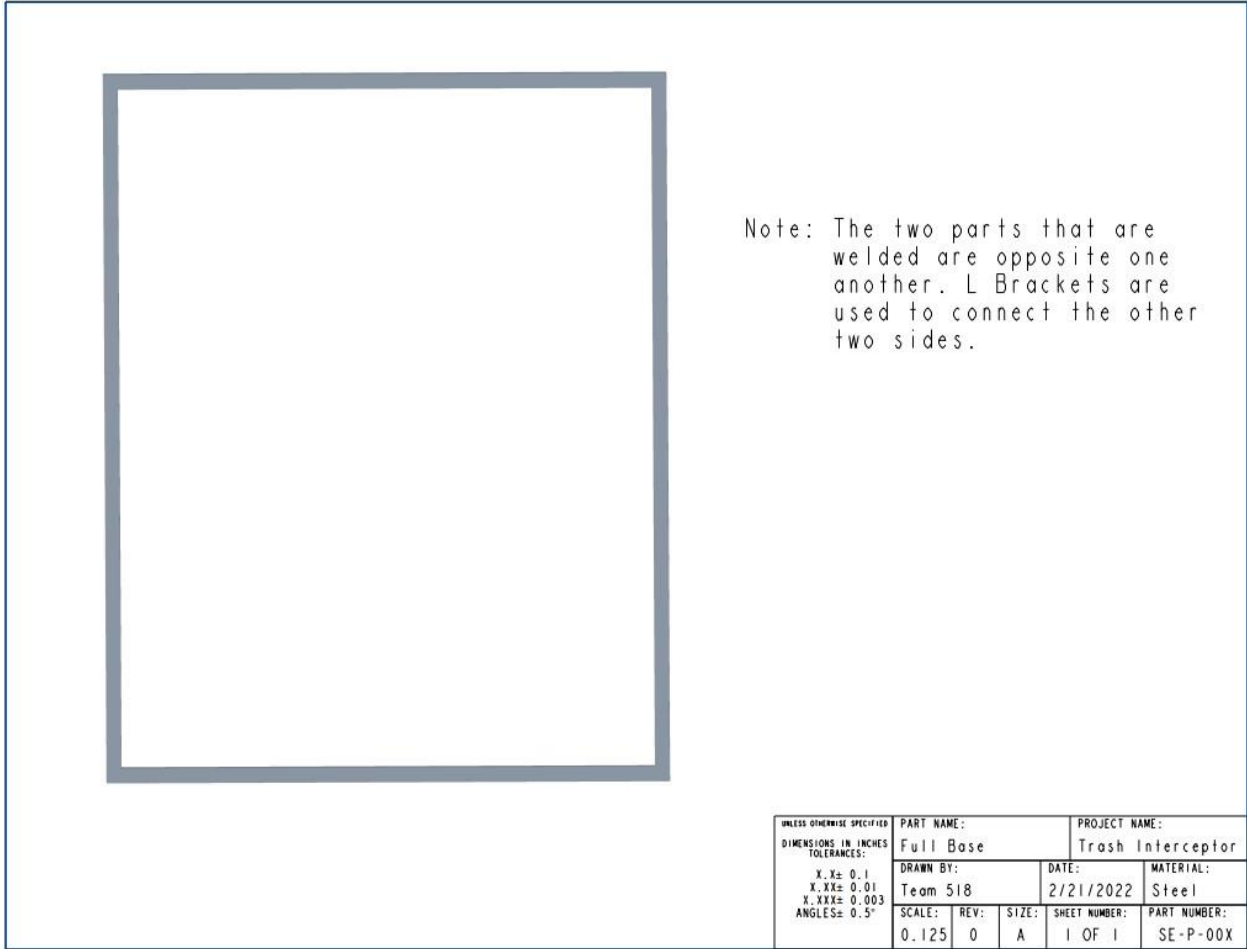

Figure 31: Full Base Assembly

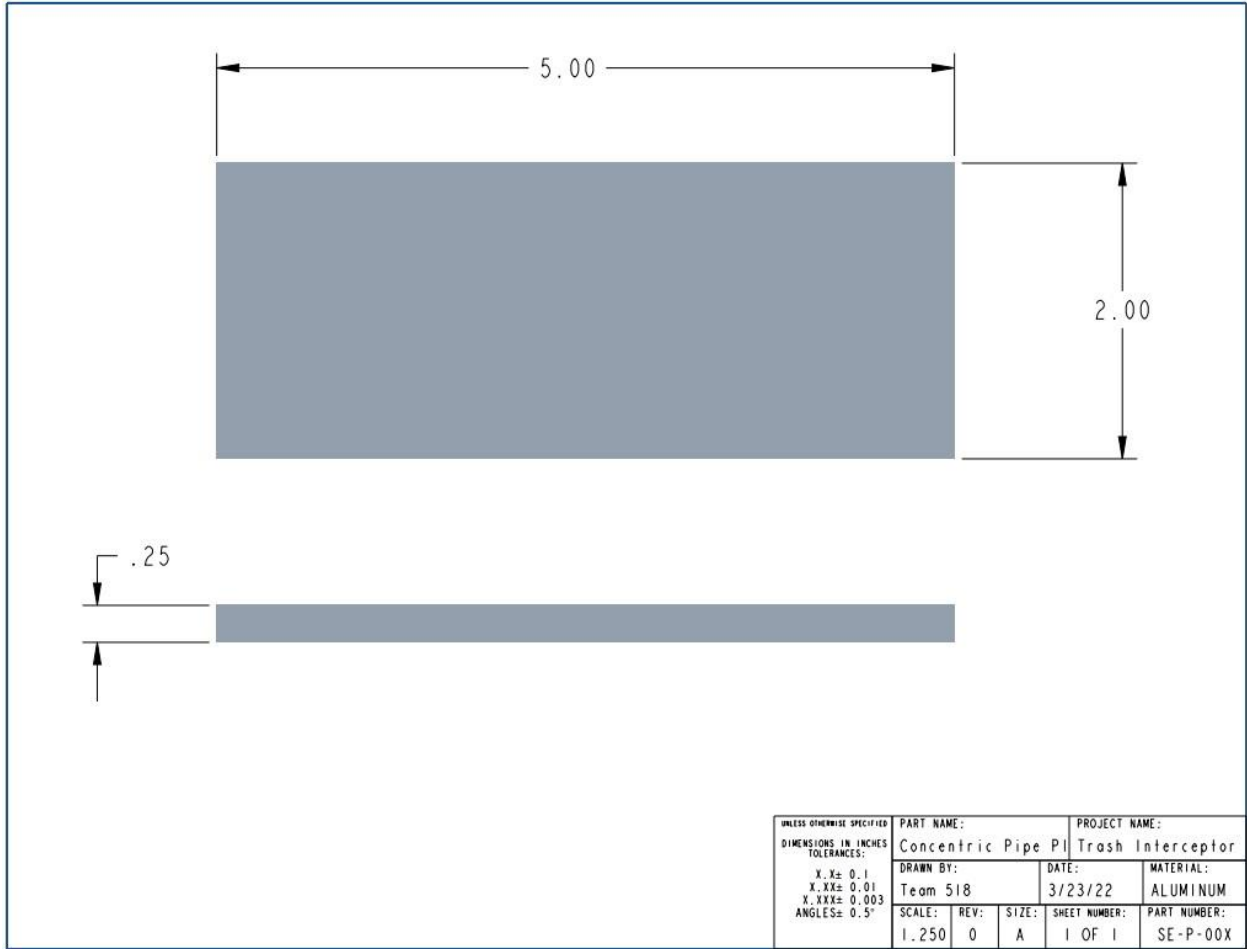

Figure 32: Concentric Pipe Plate

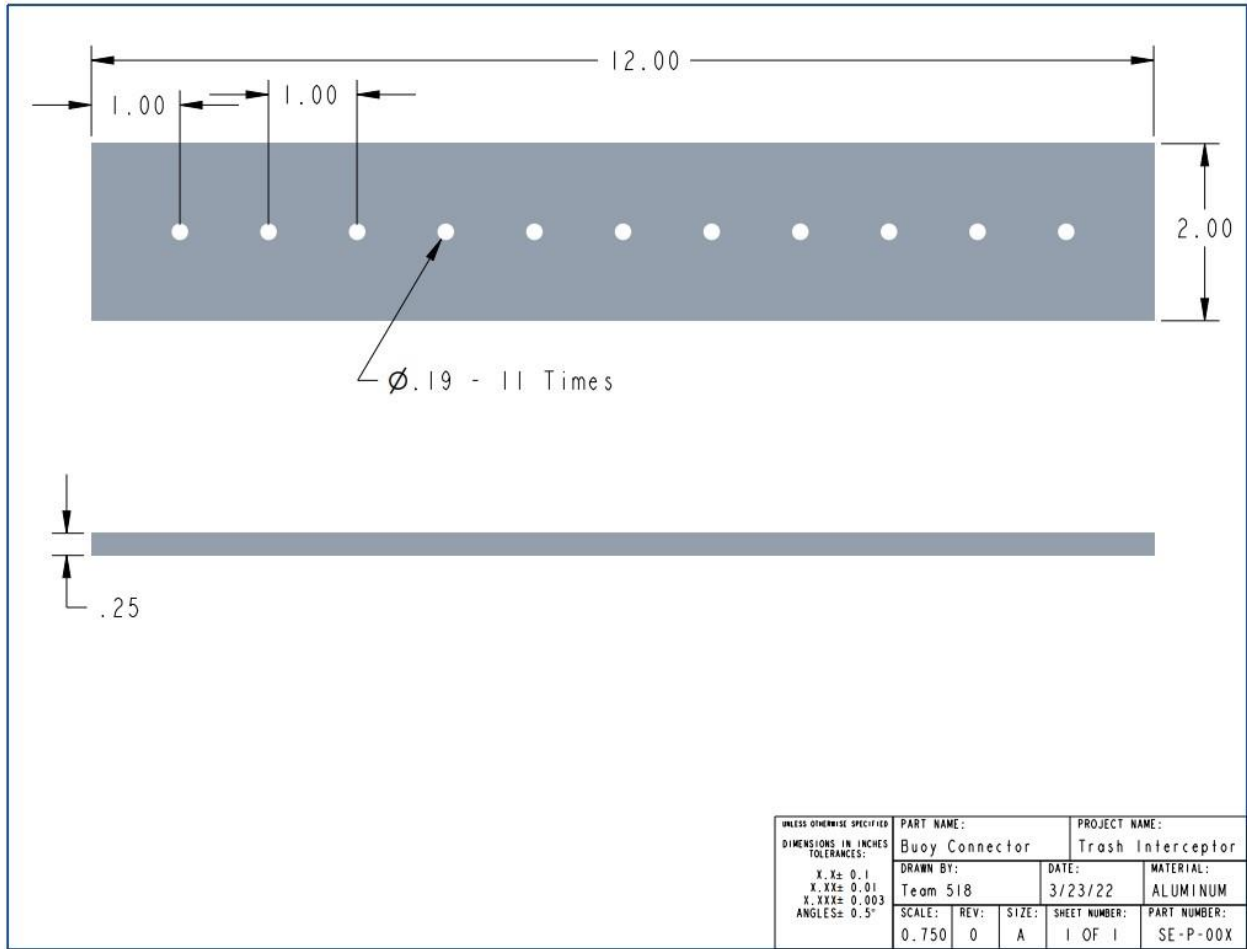

Figure 33: Buoy Connector Plate

Appendix B – Ordered Parts List

The following table is a list of all of the parts that were bought from different vendors to complete the trash interceptor.

Vendor	Model #	Project Part Name	Description	Quantity
Grainger	1Z820	Motor	DC Gearmotor: 12V DC, 23 RPM Nameplate RPM, 280 in-lb Max. Torque, CW/CCW, All Angle	1
Grainger	38EG40	Speed Controller	DC Speed Control: PWM, Open, 10 A Max Current, 12 to 48V DC, 30:1, Single Direction	1
Grainger	2UKK8	Battery	12 Volt, 20 Ah	1
McMaster	7113K462	Battery Connections	Ring Connector Nylon Insulated, for 12-10 Gauge and 1/4" Screw	1
McMaster	8054T18	Battery Wire	Stranded Wire 300V AC, 12 Wire Gauge	3
McMaster	5908K717	Ball Bearings	Ultra-Corrosion-Resistant Stainless Steel Ball Bearing	3
McMaster	94895A825	Shaft Nuts	High-Strength Steel Hex Nuts Zinc Yellow-Chromate Plated Steel—Grade 8 1/2"-20 fine thread. Pack of 25	1
McMaster	91257A751	Shaft Bolts	Zinc Yellow-Chromate Plated Grade 8 Steel Partially 1/2"-20 length 3". Pack of 5	1
McMaster	3274T78	Eye Bolts	Eye Diameter 7/8" Base Diameter 3/4"	2
McMaster	2134N54	Stabilizing Cable	1/8"x10'	2
McMaster	6300A41	Corkscrew Eye bolts	15" Length x 4" Blade x 1/2" Rod x 1" eye	2
McMaster	6436K74	Shaft Collars	Clamping Two-Piece Shaft Collar for 1-1/4" Diameter, 2024 Aluminum (2 Included)	2
McMaster	1978N47	Temporary Reservoir	Wire Bin Box 16-1/4" Width x 14-1/2" Depth x 7" Height	1
Grainger	56KP39	Timing Belt	Industrial Timing Belt: 210L100, 21 in Pitch Lg, 56 Teeth, 3/8 in Pitch, Neoprene	1
Grainger	6PTU5	Shaft Belt Bushing	Split Taper Bushing: G, 1 in Bore Dia., 1 in Lg	1
Grainger	6GEH8	Shaft Belt Gear	Gearbelt Pulley: 21 Grooves, 3/8 in Pitch, 2.477 in Outside Dia., 2.507 in Pitch Dia., G	1
Grainger	6PTV0	Motor Shaft Bushing	Split Taper Bushing: G, 5/8 in Bore Dia., 1 in Lg	1
Grainger	6GEH5	Motor Belt Gear	Gearbelt Pulley: 18 Grooves, 3/8 in Pitch, 2.119 in Outside Dia., 2.149 in Pitch Dia., G	1
Grainger	26KH36	Solar Panel	Solar Panel, Cell Type Polycrystalline, Nominal Output Power 5 W, Number of Cells 36	1
McMaster	92620A548	Bracket Bolts	Zinc Yellow-Chromate Plated Hex Head Screw Grade 8 Steel, 1/4"-20 Thread Size, 1-3/4" Long, Fully Threaded (includes 25)	3

Vendor	Model #	Project Part Name	Description	Quantity
McMaster	97135A210	Bracket Nuts	High-Strength Steel Nylon-Insert Locknut, Grade 8, Zinc Yellow-Chromate Plated, 1/4"-20 Thread Size (includes 25)	3
McMaster	1556A39	Base L Bracket	Zinc Plated Steel Corner Bracket	2
McMaster	98870A340	Key for Basket Shaft	1018-1045 Steel, 3/16" x 3/16", 1" Long, Oversized	1
McMaster	3755N185	Reservoir Washer	High-Strength Slippery UHMW Polyethylene Sheet, 6" x 6", 1/4" Thick	1
McMaster	1088A33	Base Gussets	Inside-Corner Reinforcing Bracket with 3" long sides	4
McMaster	3200T53	Motor Gusset	Strut Channel Shelf Bracket	1
McMaster	97447A060	Rivets	Aluminum Blind Rivets with Aluminum Mandrel, Domed Head, 3/16" Diameter, for 0.376" - 0.5" Material Thickness (pack of 100)	1
McMaster	8975K71	Buoy Attachment	Multipurpose 6061 Aluminum, 1/4" Thick x 2" Wide, 1 Foot Long	3
Grainger	6AYD4	Fuse Holder	In-Line Fuse Holder: 1 Poles, 0 to 20 A, 32V DC, Wire Leads, Non indicating, Covered	1
McMaster	3001K22	Buoys	3 Gallon Bottle for Water Dispenser	2