

Objective

To measure and modify air quality in the FAMU-FSU College of Engineering to promote a healthy building environment.

Background

Coronavirus is transmitted through respiratory droplets in air. Maintaining good air quality during the COVID-19 pandemic is key in preventing the spread of disease.

Design Description

- Two portable carts used to sense and alter air quality
- The carts will collect air quality data and clean air if necessary
- One cart used for short-term, high frequency data collection
- The other cart used for long-term, low frequency data collection
- Carts can be used independently in different locations or together in one location for rapid cleaning

Connection Diagram

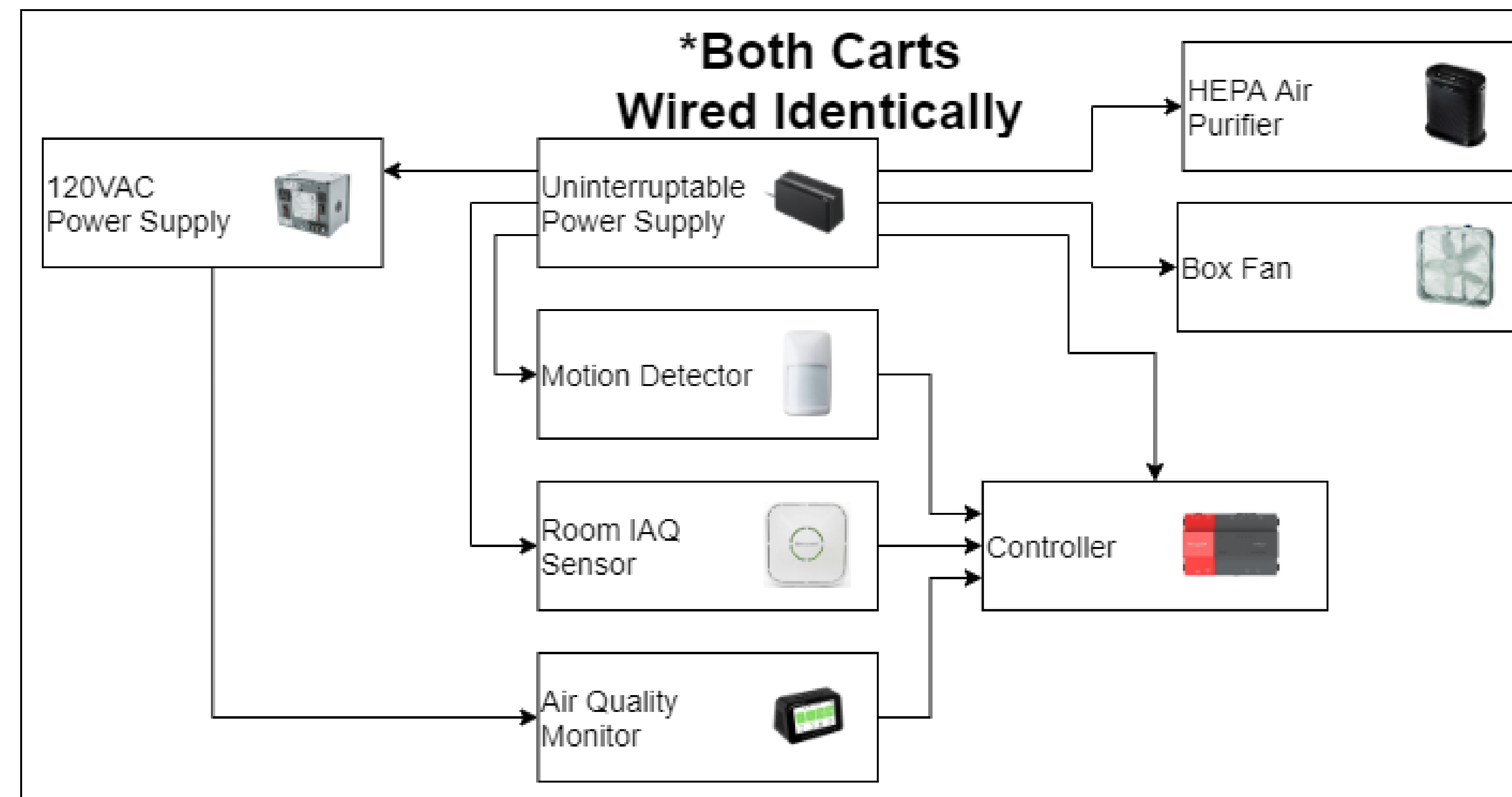

This connection diagram shows how equipment on the carts is wired together. The sensors measure air quality and detect the presence of people, the controller records the gathered data, and the fan and air purifier are used to modify the air quality.

Final Design

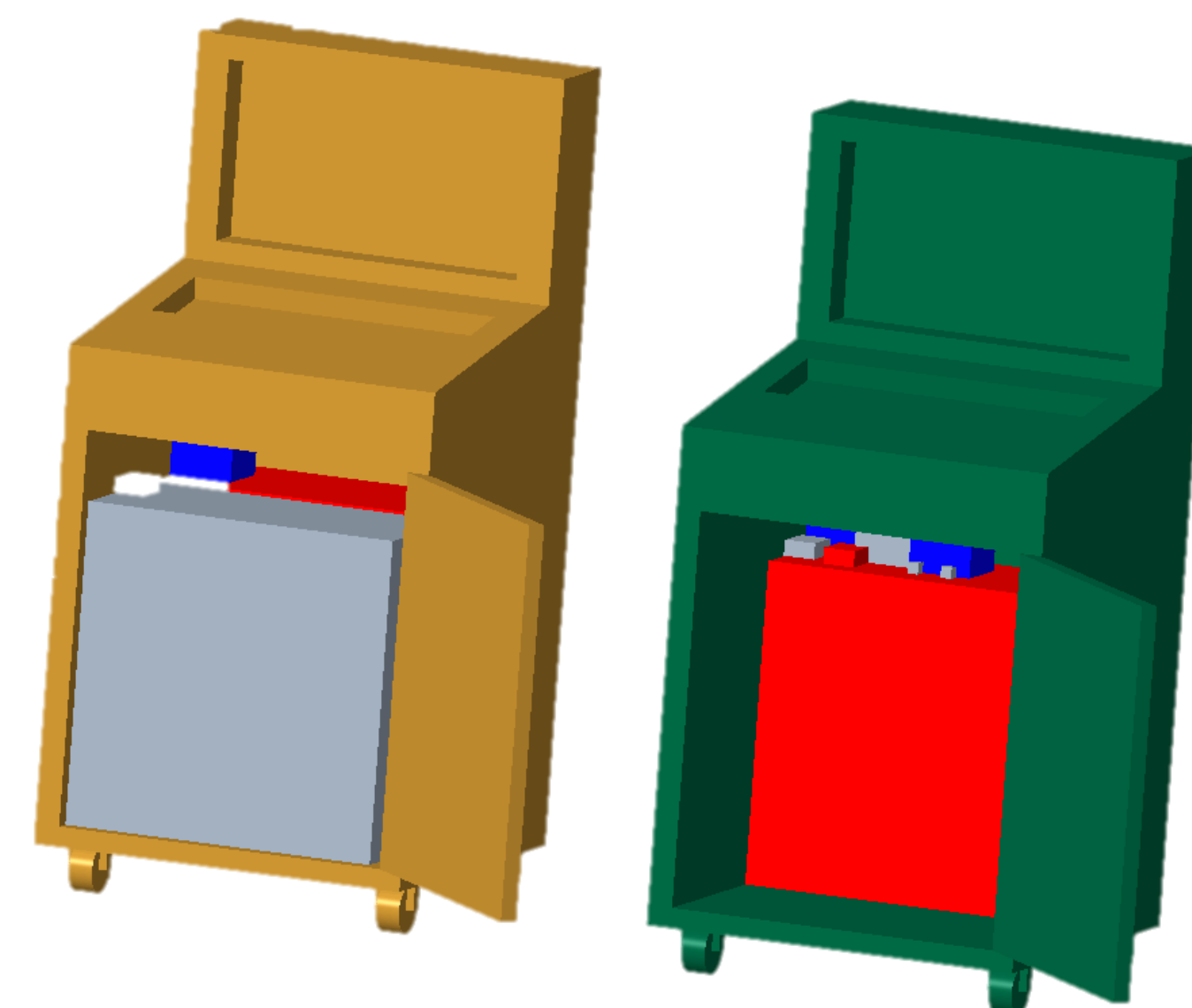

Conclusions

Sensors can be used to gather data on indoor air quality. Cleaning equipment, including fans and air purifiers can be used to modify air quality. Fans should be placed in areas of low airflow to promote circulation. Air purifiers should be located in areas of high air flow, so as much air as possible passes through them.