

EML 4550: Roboboat 2020

Concept Selection and Rendering



Team Introductions



Brandon Bascetta
Mechanical Engineer



Courtney Cumberland
Mechanical Engineer



Toni Weaver
Mechanical Engineer

Sponsor and Advisor



Engineering Mentor/Academic Advisor

Damion Dunlap
Department Head

Objective

Design a new boat for the 2020 Roboboat competition

Project Background

Toni Weaver



Project Background

RoboBoat is an autonomous boat competition, created by Robonation and Sponsored by Office of Naval Research, Naval Information Warfare Center as well as by several corporations.



Toni Weaver

Project Background

- Last year the Seminole Coast team did not use any design criteria for the design of the boat.
- This resulted in a capsizing of the boat.
- To prevent this from happening this year the team is tasked with designing the boat based on methods learned in EML 4550: Engineering Design Methods.



Toni Weaver

Customer Needs

Upon reviewing the customers statements from the survey customers would like the boat to be:

- Stable
- Modular
- Have Ample Size for Components
- Have an Aesthetically Pleasing Design that doesn't undercut Functionality

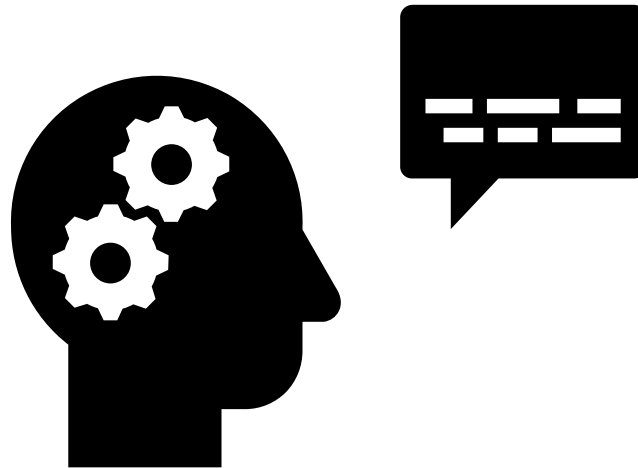

Toni Weaver

Functional Decomposition

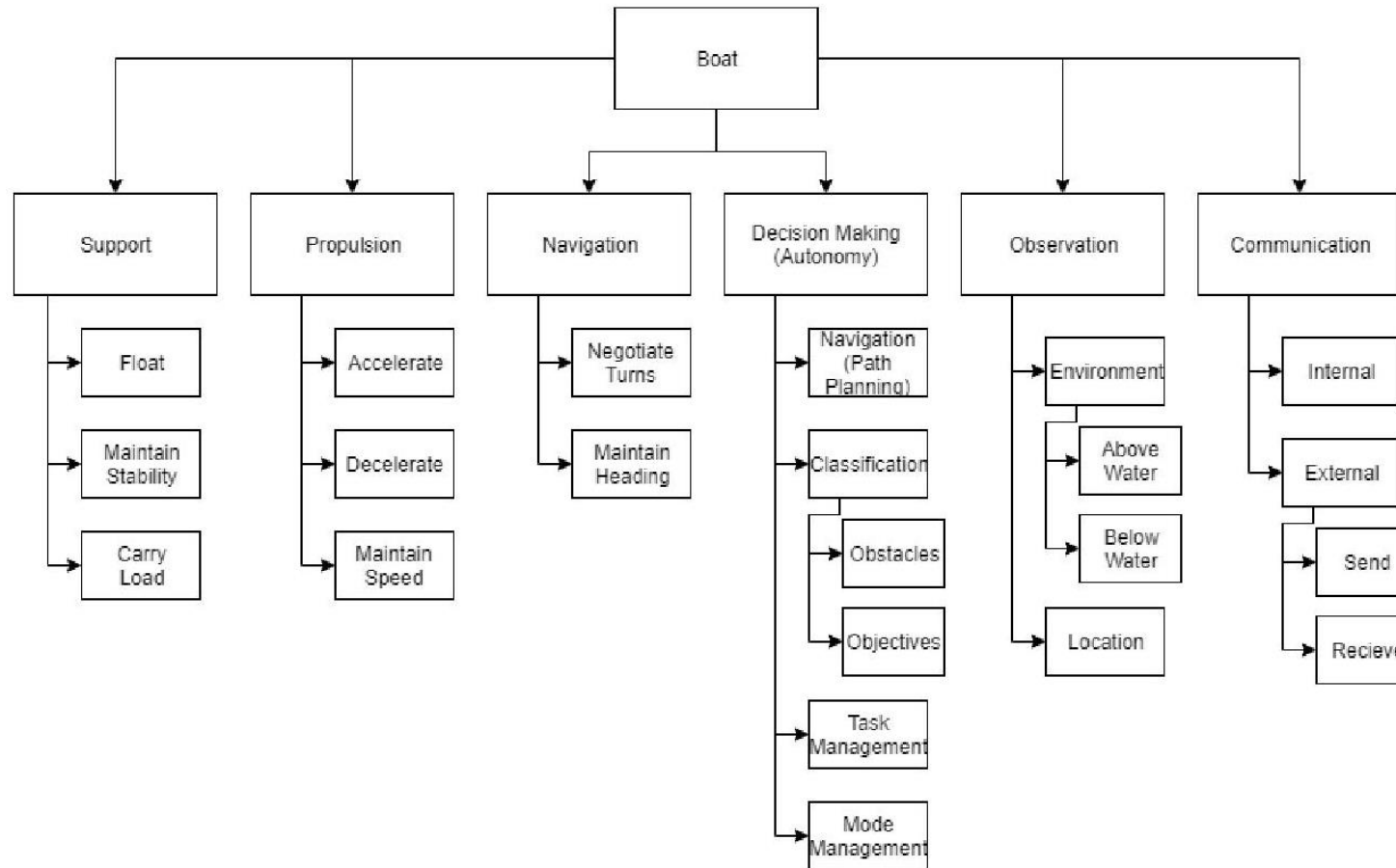

Toni Weaver

Concept Decision Matrices

Brandon Bascetta



Morphological Chart

Hull	Super Structure (Material)	Propulsion	Sensor	Cooling System	Connection
Catamaran	Cardboard	Differential Thrus	Spider Rail	Fans(Active)	Rail System
Monohull	Tuberware	2 vector Thrust	Tree Stump	Vents (Passive)	Grenade Pin
Round	Pelican Box	4 Vector Thrust	Narwhal	Water Cooling	Snap Down
Trimaran	Carbon Fiber	rudder	Hole-y Board	Mineral Oil	Clam Shell (Hinge)
Hovercraft	Same Material	Sail	Tower of Terror		Convertible (Corvette)
	Wood				

	Concept Assemblies					
Concept 1	Cat/Mono	Same Material	Differential	Spider Rail	Active	N/a
Concept 2	Cat/Mono	Modular	Differential	Spider Rail	Active	Grenade Pins
Concept 3	Long Cat	Same Material	Differential	Spider Rail	Active	N/a
Concept 4	Long Cat	Modular	Differential	Spider Rail	Active	Snap Down

Brandon Bascetta



Pugh Chart

Selection Criteria	DATUM (Wilson)	1	2	3	4
Stability		+	+	+	+
Aesthetics		+	+	+	+
Maneuvaribility		+	+	+	+
Modularity		S	+	S	+
Deck Space		+	+	+	+
Manufacturability		+	+	+	+
Speed		+	+	+	+
Number of +'s		6	7	6	7
Number of -'s		0	0	0	0

Selection Criteria	DATUM (Concept 4)	1	2	3
Stability		S	S	S
Aesthetics		S	S	S
Maneuvaribility		+	+	S
Modularity		-	S	-
Deck Space		+	-	S
Manufacturability		-	-	-
Speed		+	+	+
Number of +'s		3	3	1
Number of -'s		2	2	2

Brandon Bascetta



Binary Piecewise Comparison

	1	2	3	4	5	6	7	Total
Stability	-	1	0	1	1	1	1	5
Aesthetics	0	-	0	1	1	1	0	3
Maneuvaribility	1	1	-	1	1	1	1	6
Modularity	0	0	0	-	0	1	0	1
Deck Space	0	0	0	1	-	1	1	3
Manufacturability	0	0	0	0	0	-	1	1
Speed	0	1	0	1	0	0	-	2

Brandon Bascetta

Concept Selection

Customer Requirements	Importance Weight Factor	Concept 1	Concept 2	Concept 3	Concept 4
Stability	5	3	3	3	3
Aesthetics	3	3	3	3	3
Maneuverability	6	1	1	3	3
Modularity	1	0	9	0	9
Deck Space	3	9	3	1	0
Manufacturability	1	3	3	9	9
Speed	2	3	3	1	1
Raw Score:	189	66	57	56	62

Concepts	
1	Monocat Integrated
2	Monocat Modular
3	Long Cat Integrated
4	Long Cat Modular

Brandon Bascetta

Renderings

Courtney Cumberland



Concept Renderings: Concept 1

Concept 1:

- Mono Hull/Catamaran Hybrid
- Integrated Hull
- Differential Thrust
- Active Air Cooling
- “Spider Rail” Sensor Mount

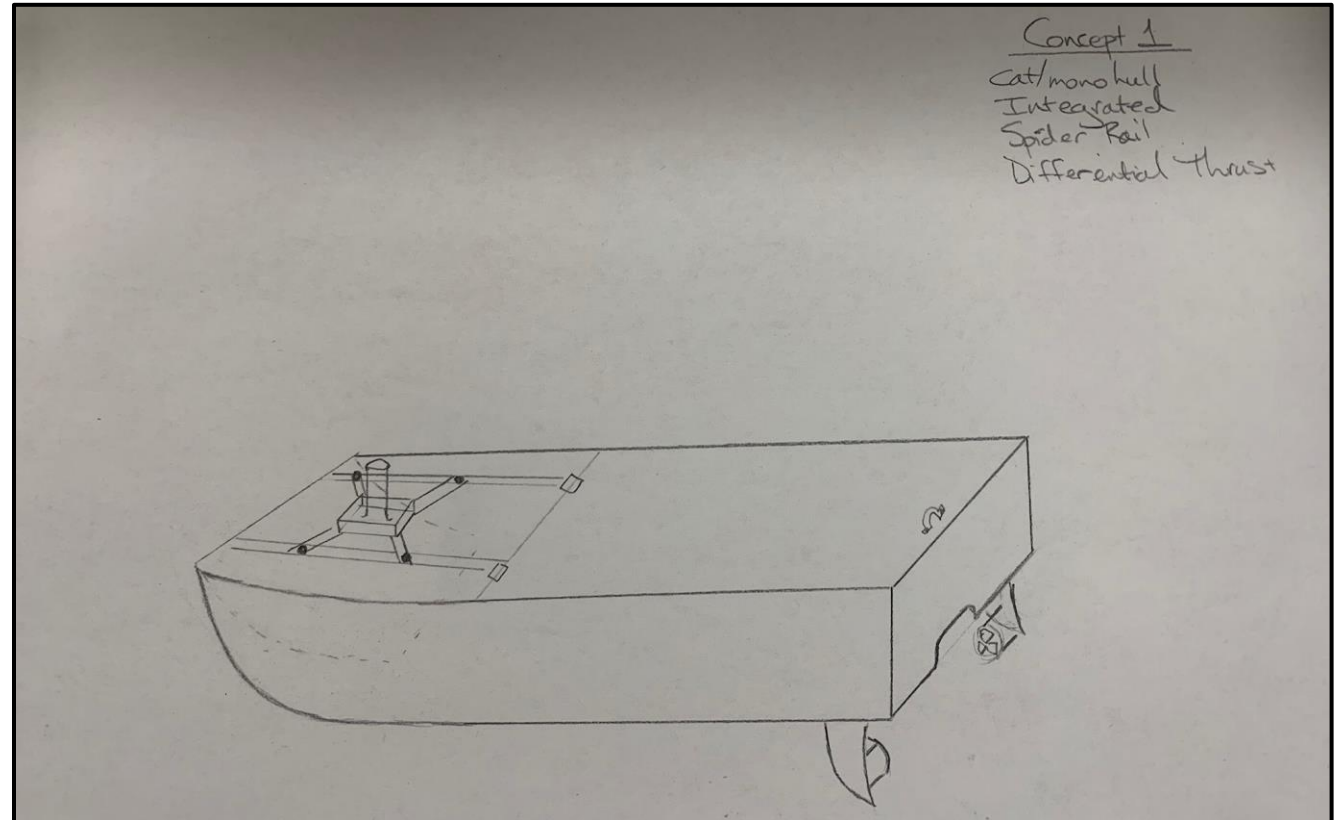

Courtney Cumberland

Concept Renderings: Concept 2

Concept 2:

- Mono Hull/Catamaran Hybrid
- Modular
- Differential Thrust
- Active Air Cooling
- “Spider Rail” Sensor Mount
- “Grenade Pin” Connection

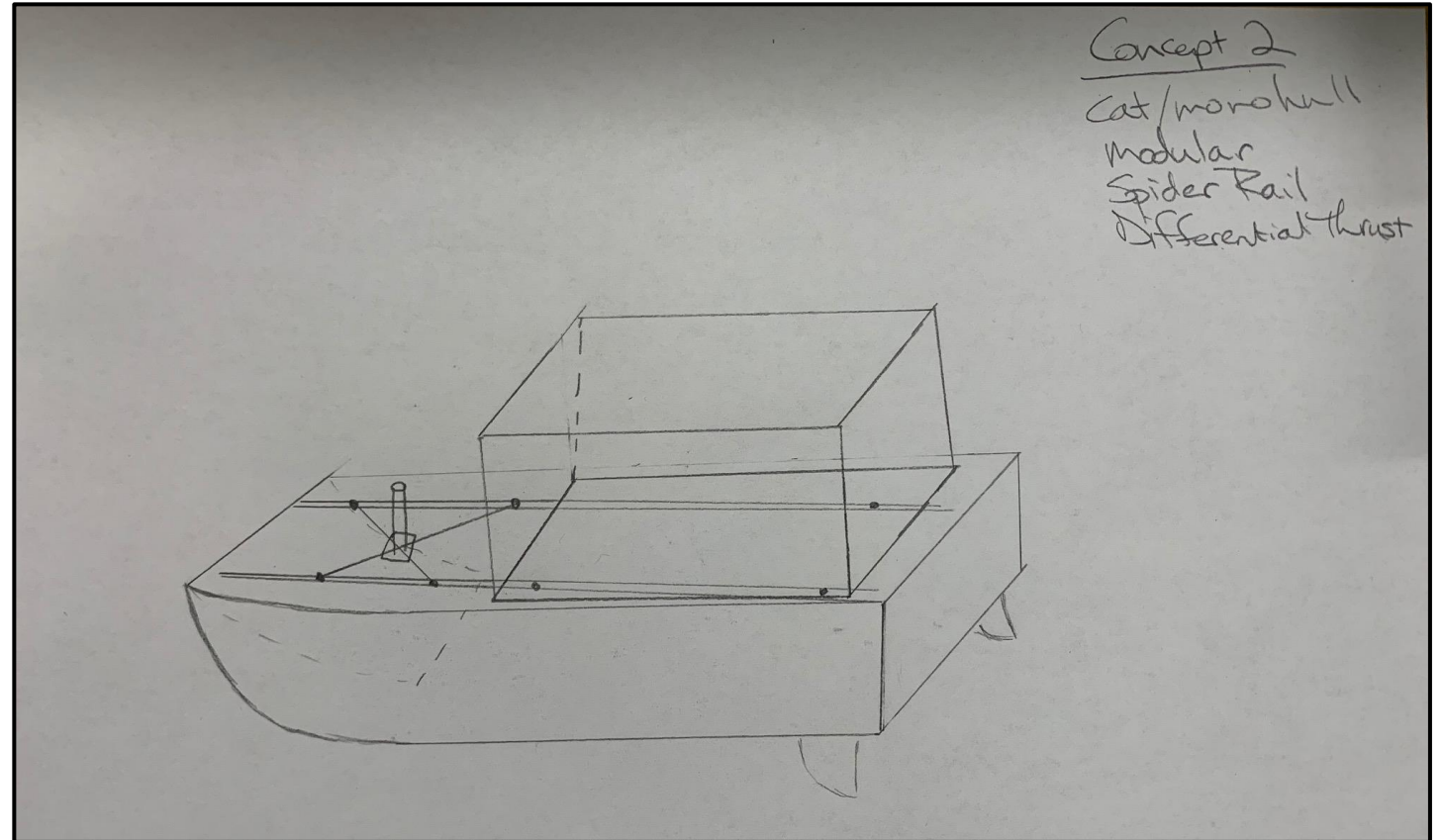

Courtney Cumberland

Concept Renderings: Concept 3

Concept 3:

- Long Catamaran Hull
- Integrated Hull
- Differential Thrust
- Active Air Cooling
- “Spider Rail” Sensor Mount

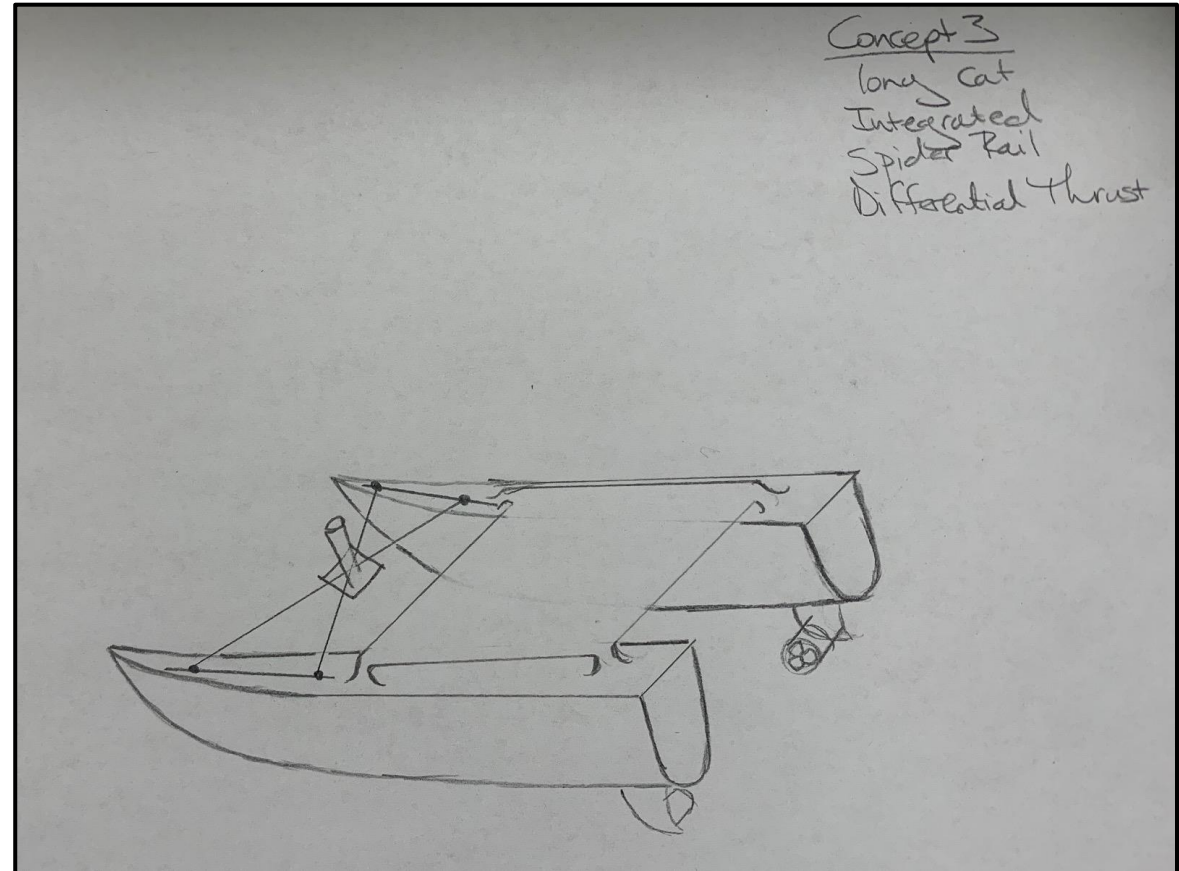

Courtney Cumberland

Concept Renderings: Concept 4

Concept 4:

- Long Catamaran Hull
- Modular
- Differential Thrust
- Active Air Cooling
- “Spider Rail” Sensor Mount
- “Grenade Pin” Connections

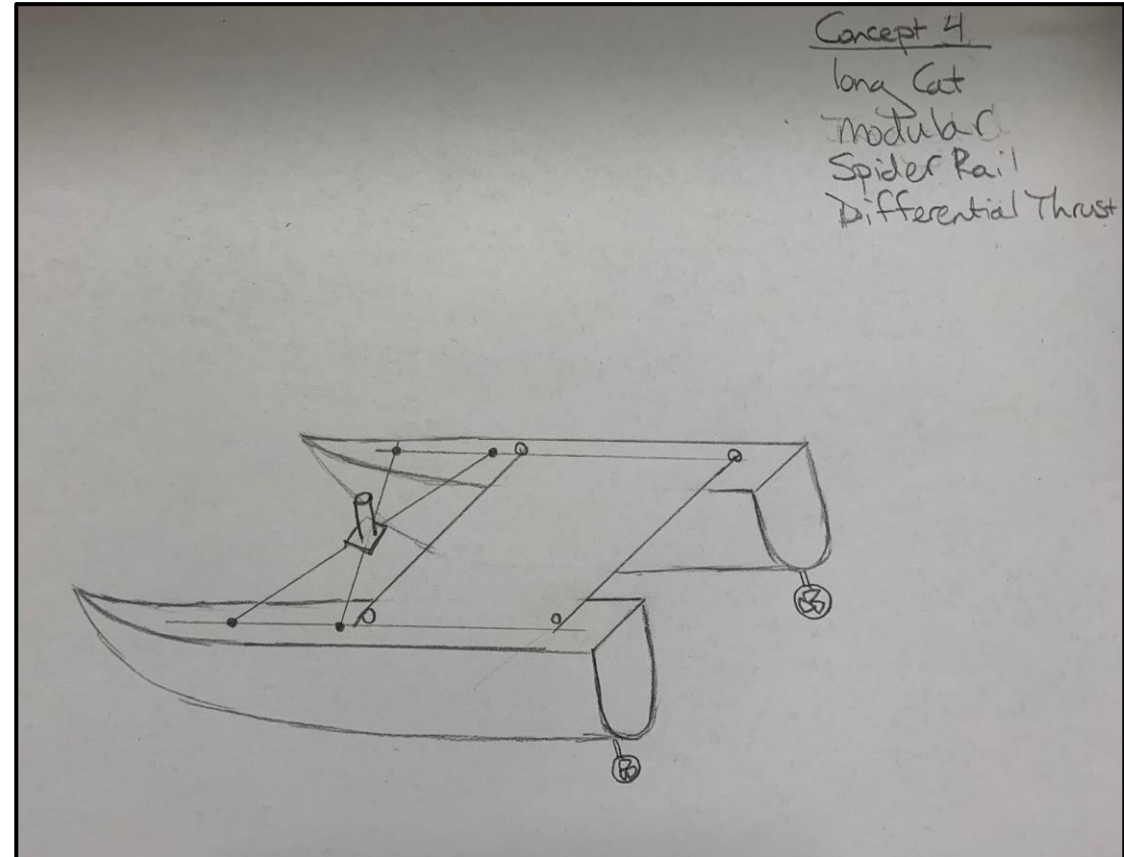

Courtney Cumberland

Concept Renderings: Higher Fidelity Design

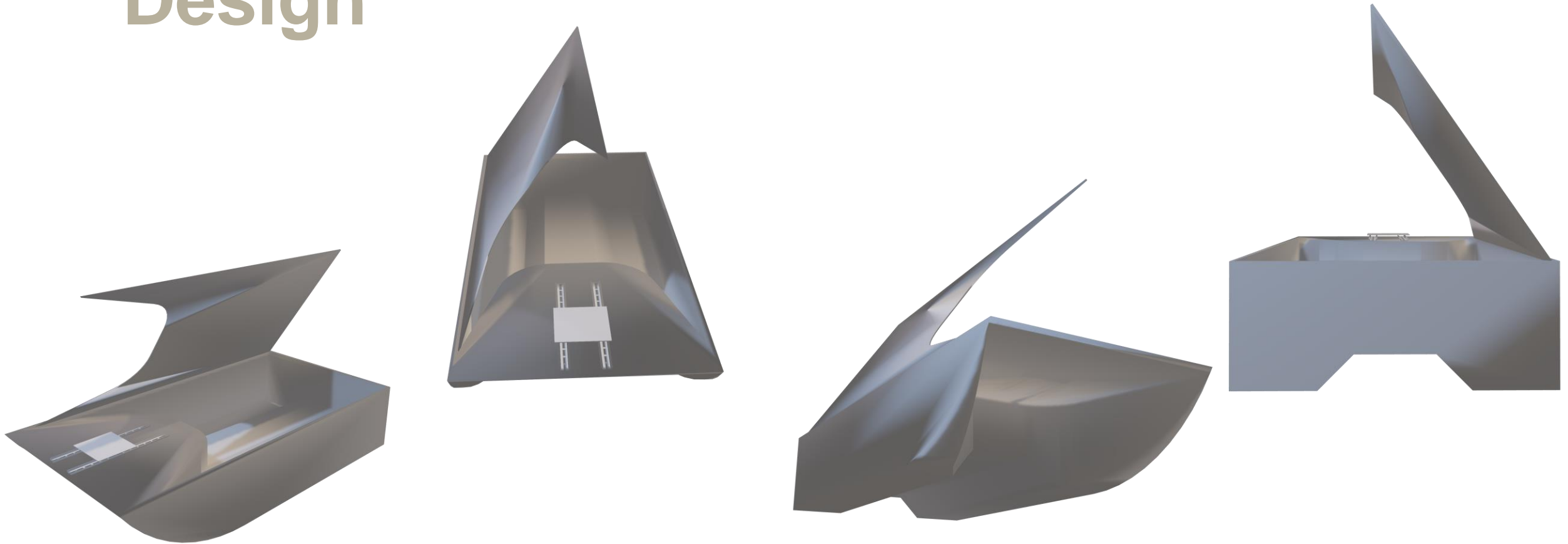

Courtney Cumberland