

Deployable Trainer Structure

Team 515: DR #4

Jarrold Darrow
Ryan Irwin
Kemuel Nelson
Christian Gonzalez

February 11, 2019



Team Introductions



Jarrold Darrow

- Quality & Test Engineer



Ryan Irwin

- Control Systems Engineer



Kemuel Nelson

- Design & Test Engineer



Christian Gonzalez

- Project Manager & Research Engineer

Sponsor and Advisor



Sponsor

Jeffrey Payne, PE
Staff Mechanical Engineer
Mission Systems & Training

Engineering Advisor

Patrick Hollis, PhD
Mechanical Engineering Professor

Christian Gonzalez

Project Overview

Background

The United States military conducts training exercises for operation of weaponized, ground vehicles via different modules of Lockheed Martin's Advanced Gunnery Training System (AGTS).

Objective

To design a portable, configurable module that is readily available for operation and eliminates the need for the user to source a chair/table.

Christian Gonzalez

Project Breakdown



Customer Requirements

- 3 cases max and each (including contents) must weigh ≤ 88 lbs.
- Support a simulator weighing 60 lbs.
- Support an individual weighing ≤ 214 lbs.
- Configurable seat distance of 25.0 ± 3.0 " relative to simulator
- Configurable seat height of 16.0 ± 3.0 " relative to the ground
- Configurable mount height of 27.0 ± 2.0 " relative to the ground

Kemuel Nelson

Functional Decomposition

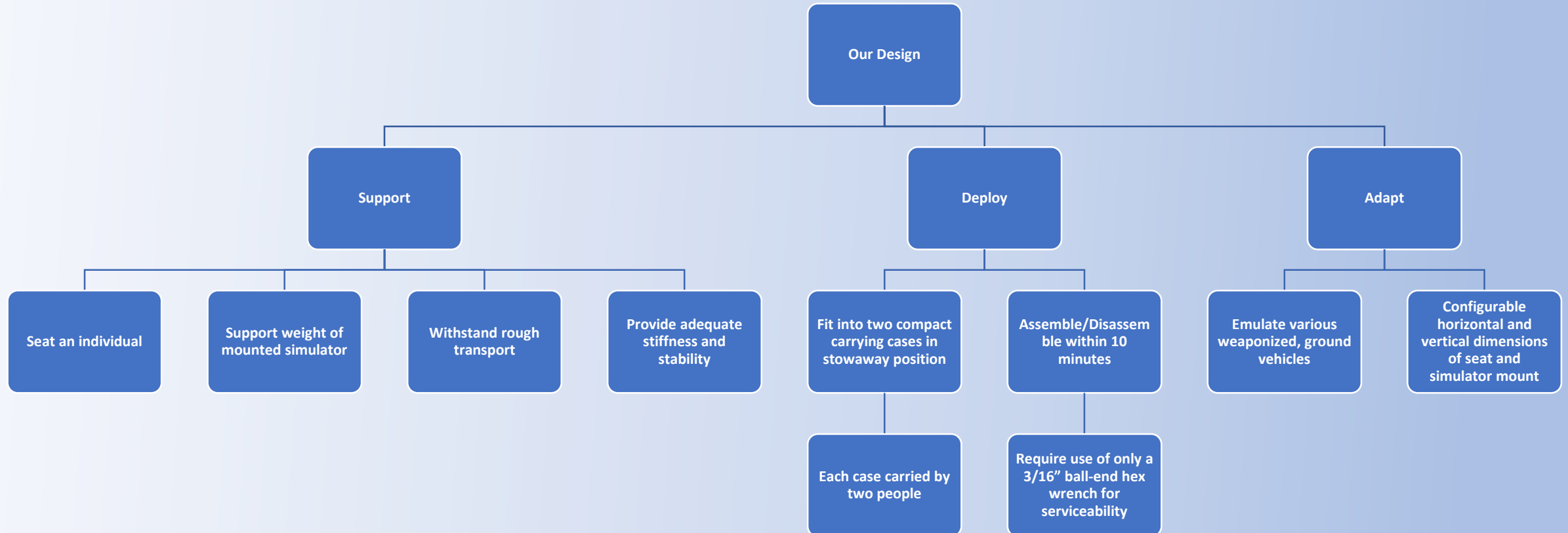

Kemuel Nelson

Functional Decomposition

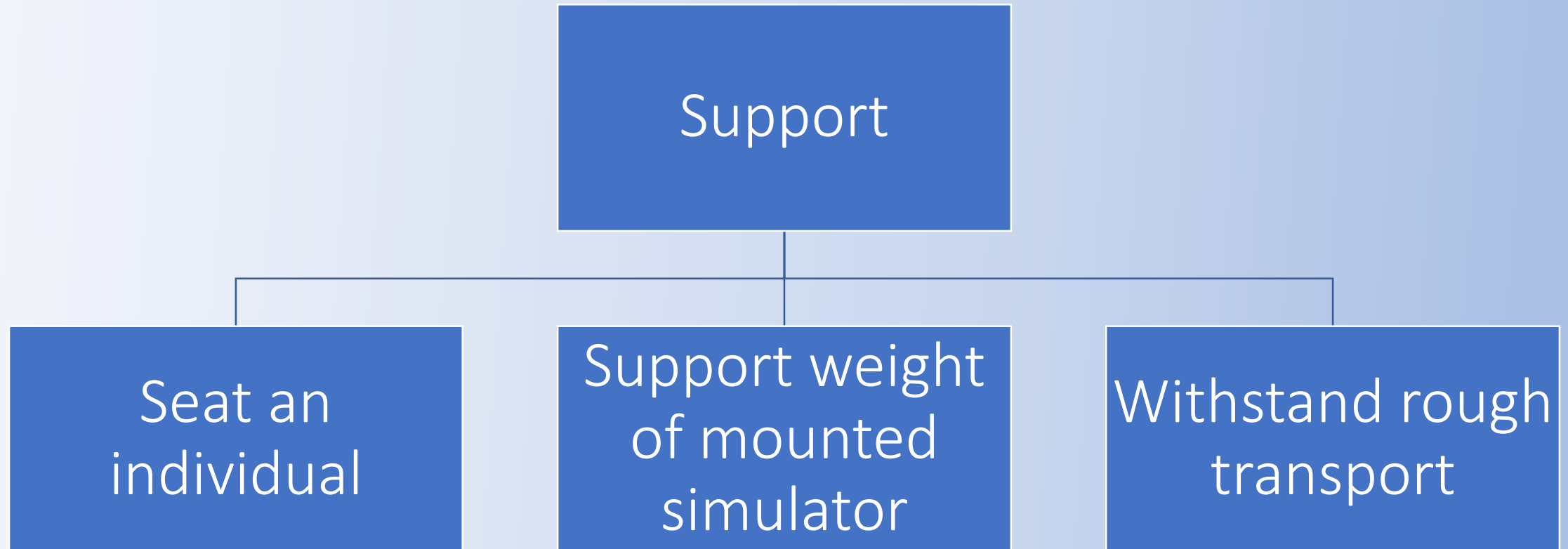

Kemuel Nelson

Functional Decomposition

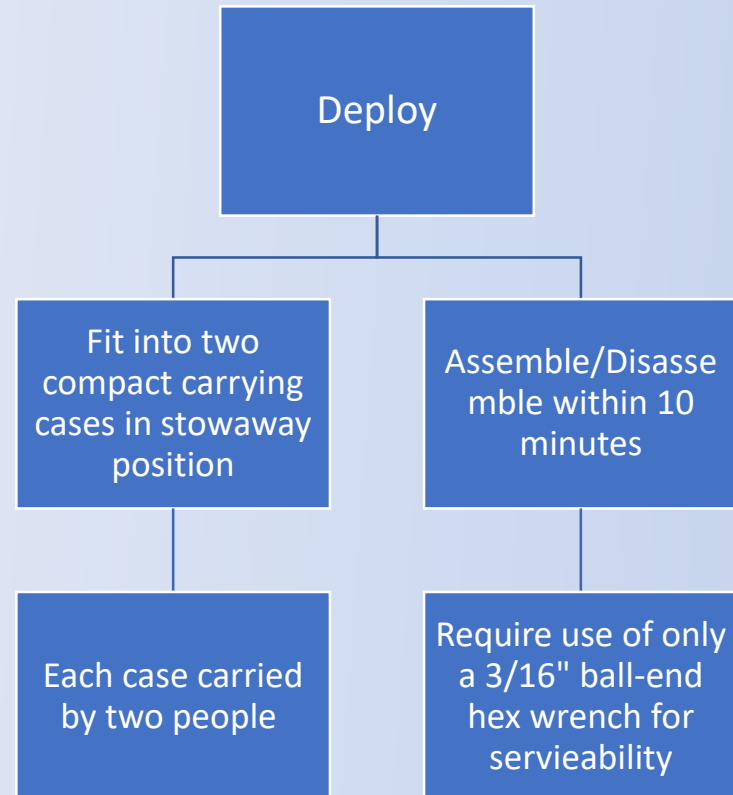

Kemuel Nelson

Functional Decomposition

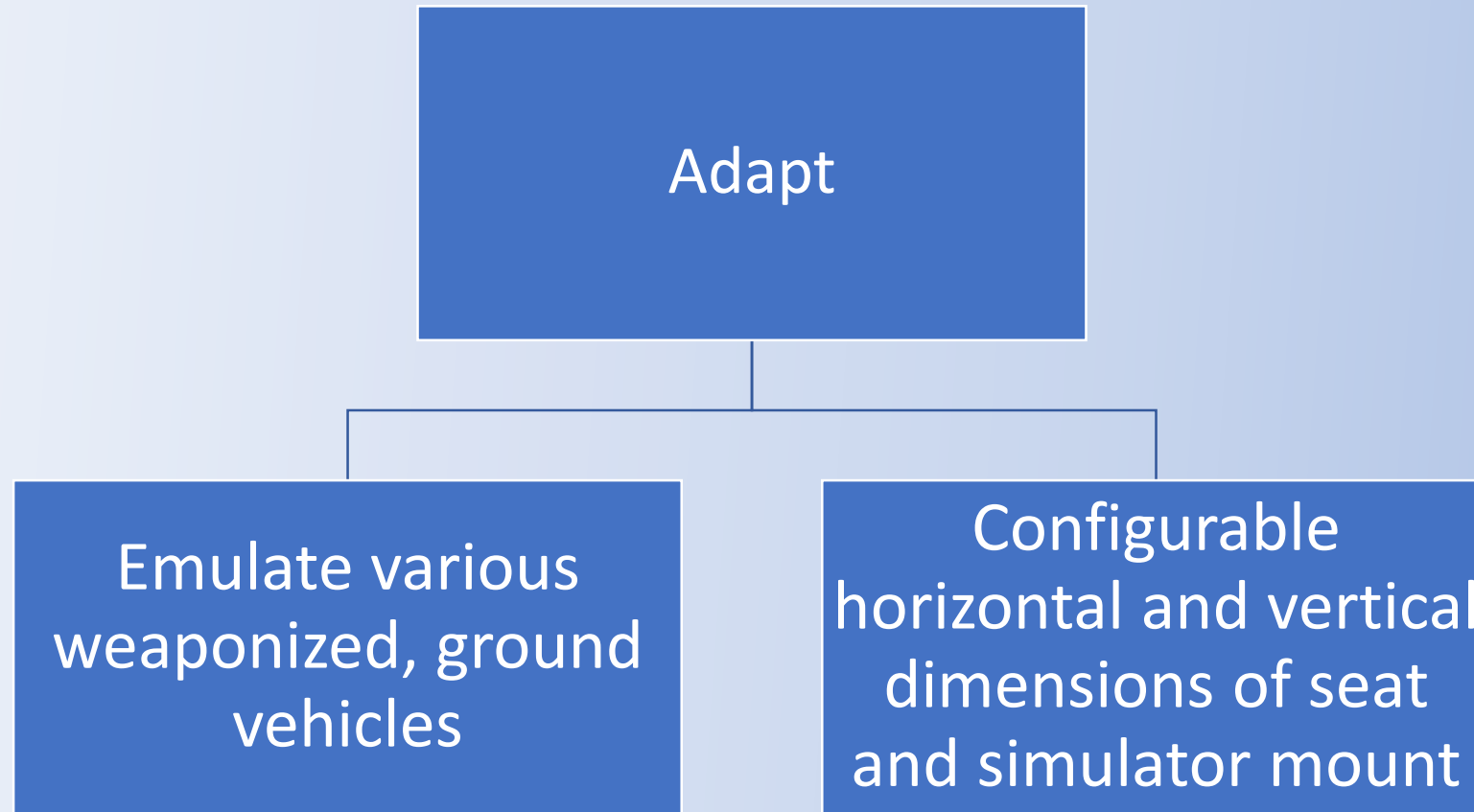

Kemuel Nelson

Design Progression



Old Design

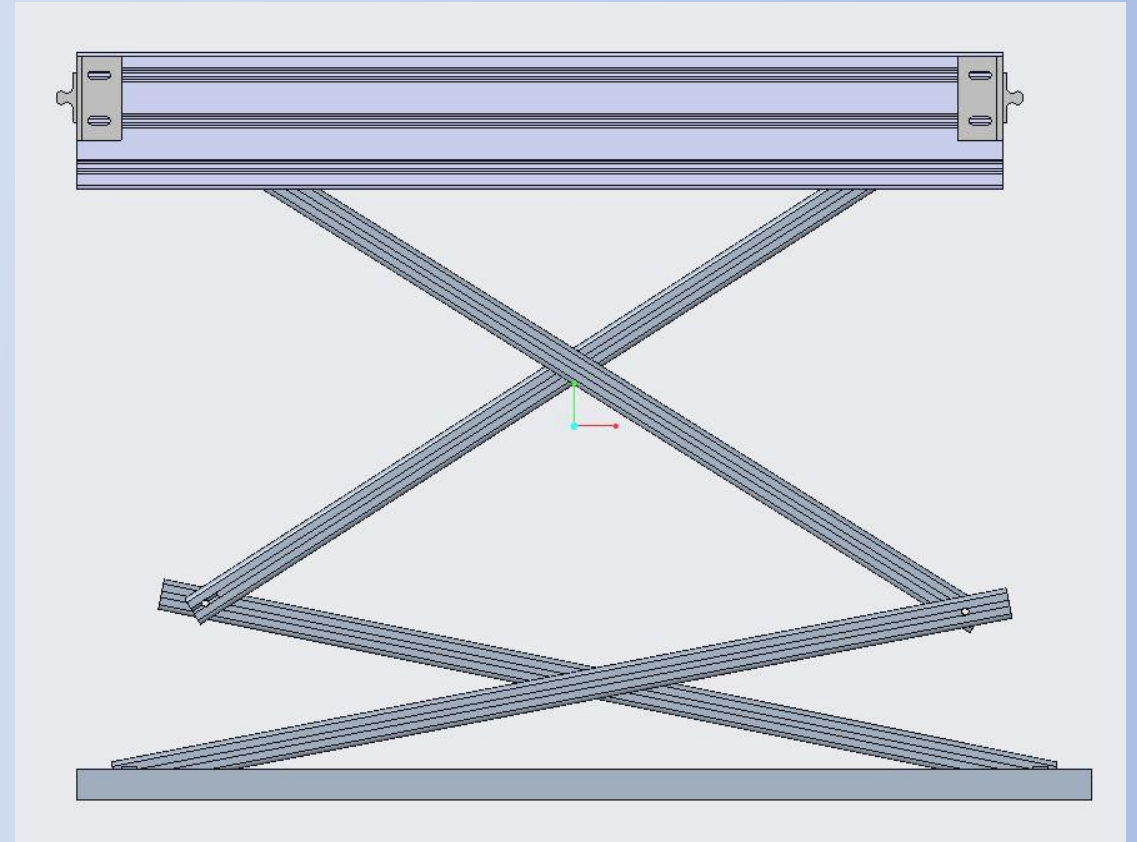
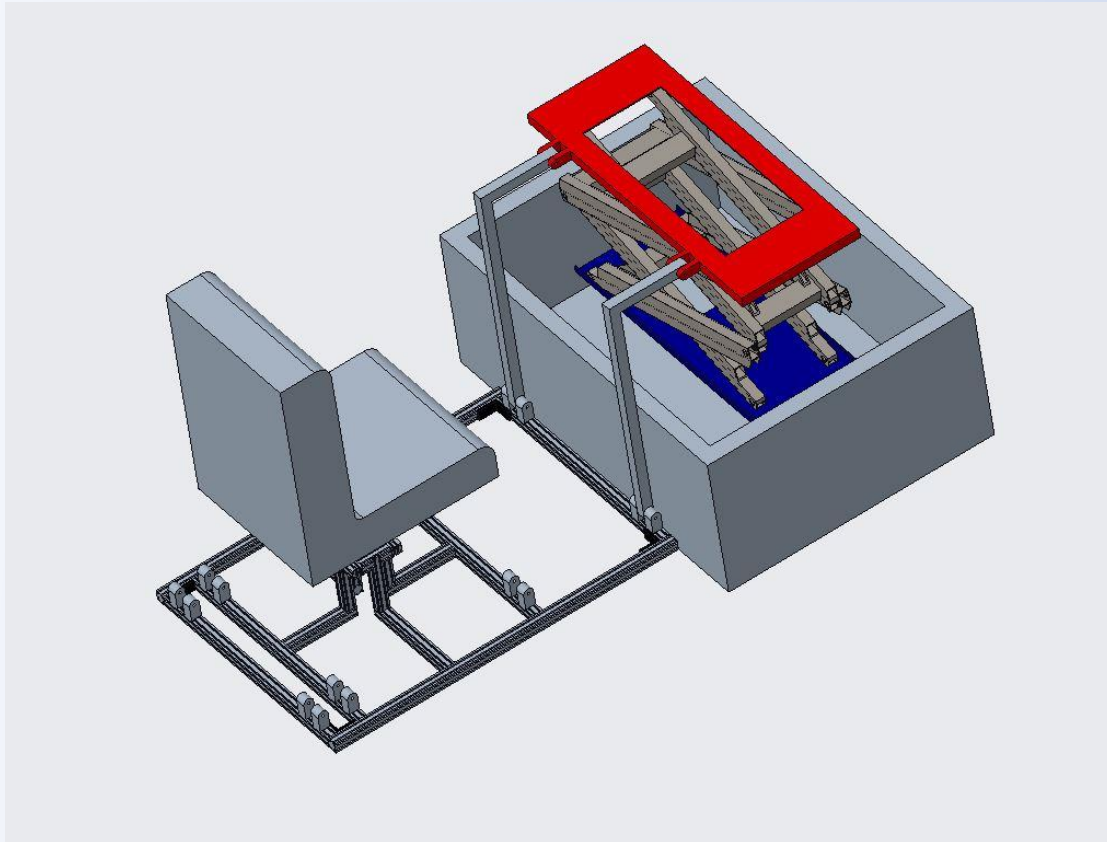

Christian Gonzalez

Old Design Issues

- Unable to fix the height of the scissor lift without creating an external component to set it.
- Did not provide a necessary, lightweight solution.
- Larger pinching hazards during setup and disassembly compared to newer design.
- The old design had a more complex motion than is necessary to set up the simulator mount.

Christian Gonzalez

Current Design

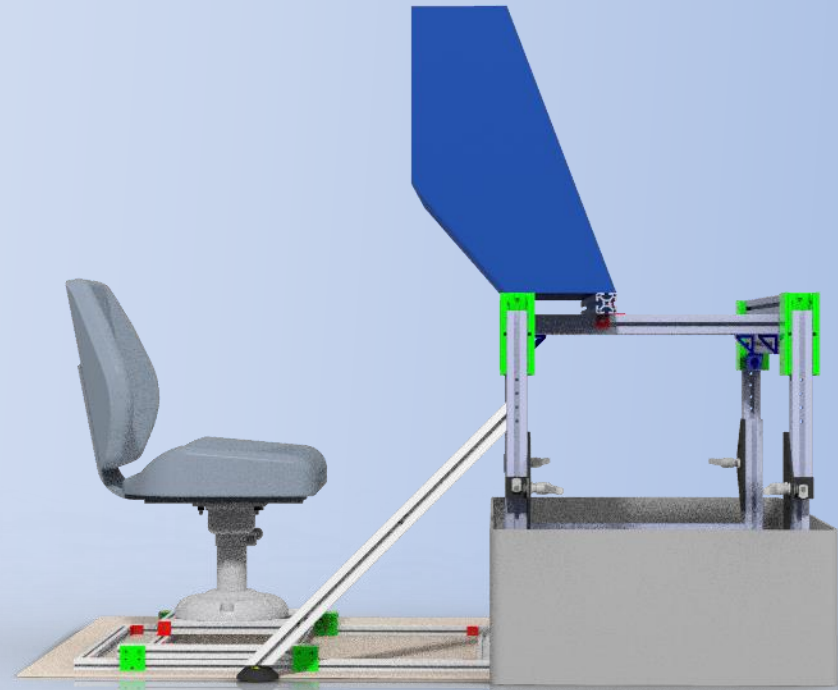
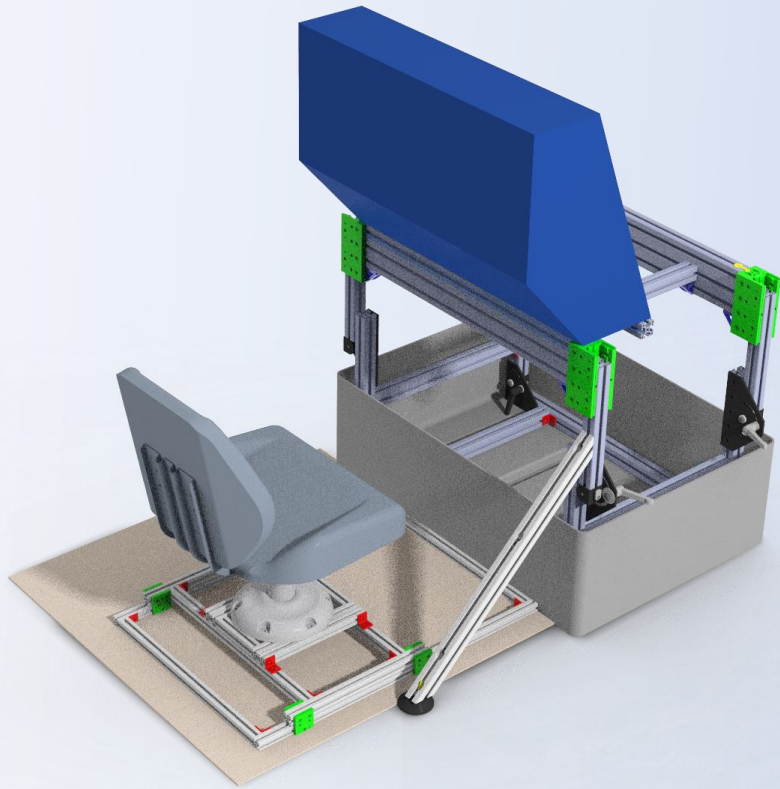

Christian Gonzalez

Improvements

- Current design uses space inside the case more efficiently.
- Geometry of the simulator-mounting bar results in smaller deflection away from the user.
- Modularity of the design has increased, allowing for further additions in the future.
- Magnitude of pinching hazards have decreased with the current design.

Christian Gonzalez

Transport 1730 Pelican Case



- Weather resistant and shockproof to withstand rough transport conditions
- Large base area to maximize stability
- Wheels for ease of transport
- Ridges on top allow the cases to stack on top of each other

Christian Gonzalez

Scotch-Weld Metal Bonder Acrylic Adhesive

- Bonds to bare and oily metals along with a variety of other materials while resisting corrosion
- Maintains high bond and shear strength in extreme environments (-40°F - 400 °F)
- High impact strength
- Moderate viscosity for accurate application
- Applications: Metal office furniture, large signs, HVAC, snowmobiles/ATV's, metal fabrication



Christian Gonzalez

Current Design

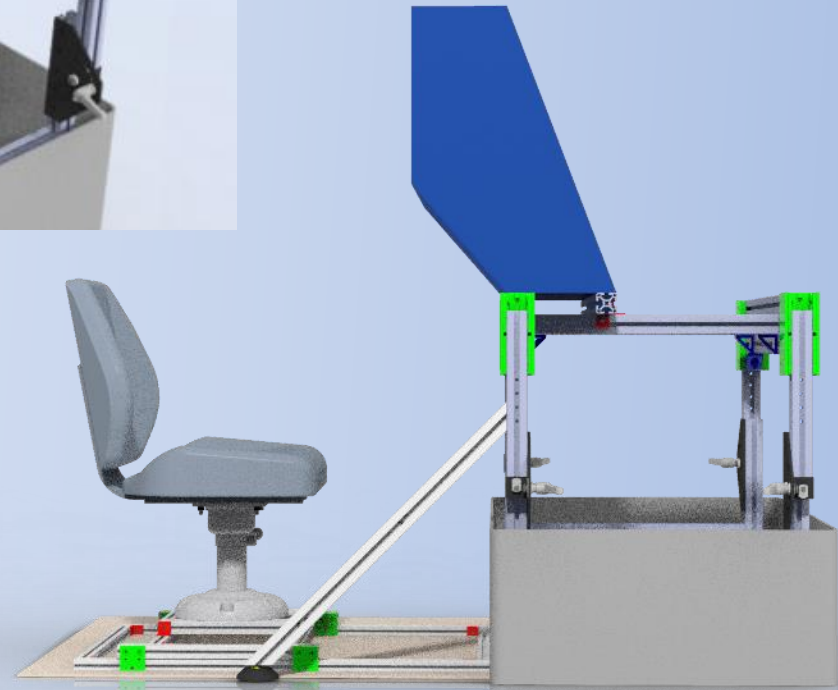
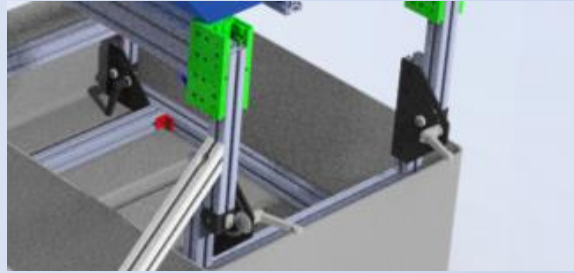
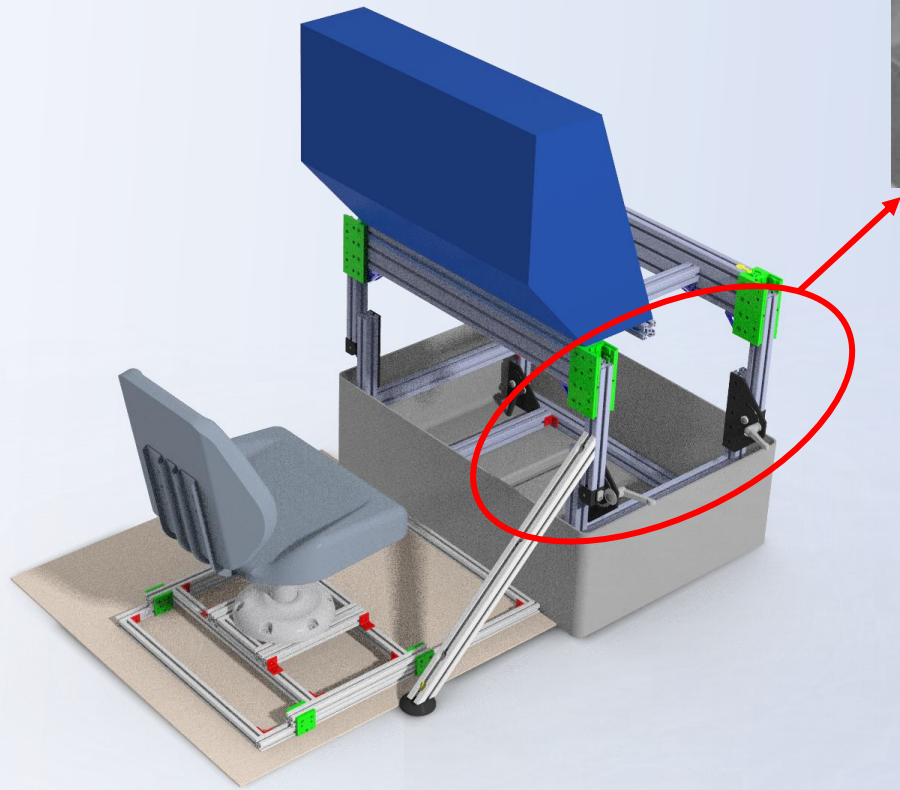

Christian Gonzalez

Simulator Mount – Middle Level



90 Degree Pivot Bracket Assembly with "L" Handle

- This mechanism allow for the bars to rotate 0-90 degrees and It offers a high load capacity while ensuring a long-life cycle.



180 Degree Pivot Bracket Assembly with "L" Handle

- This mechanism allow for the bars to rotate 0-90 degrees and It offers a high load capacity while ensuring a long-life cycle

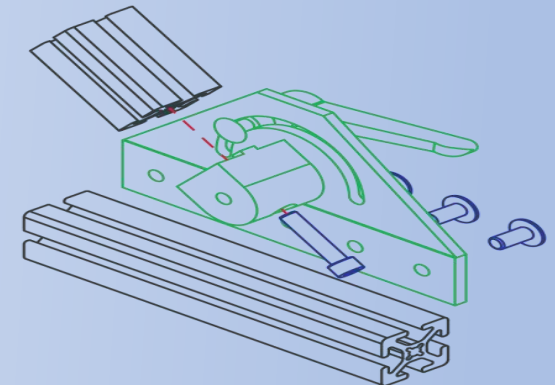
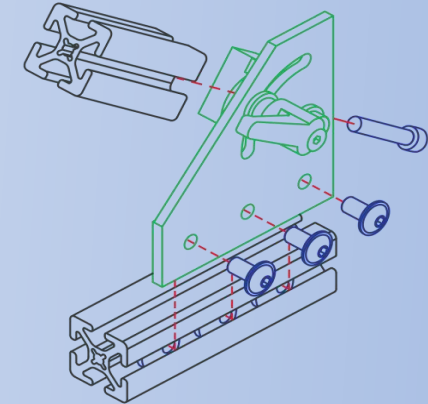

Kemuel Nelson

Current Design

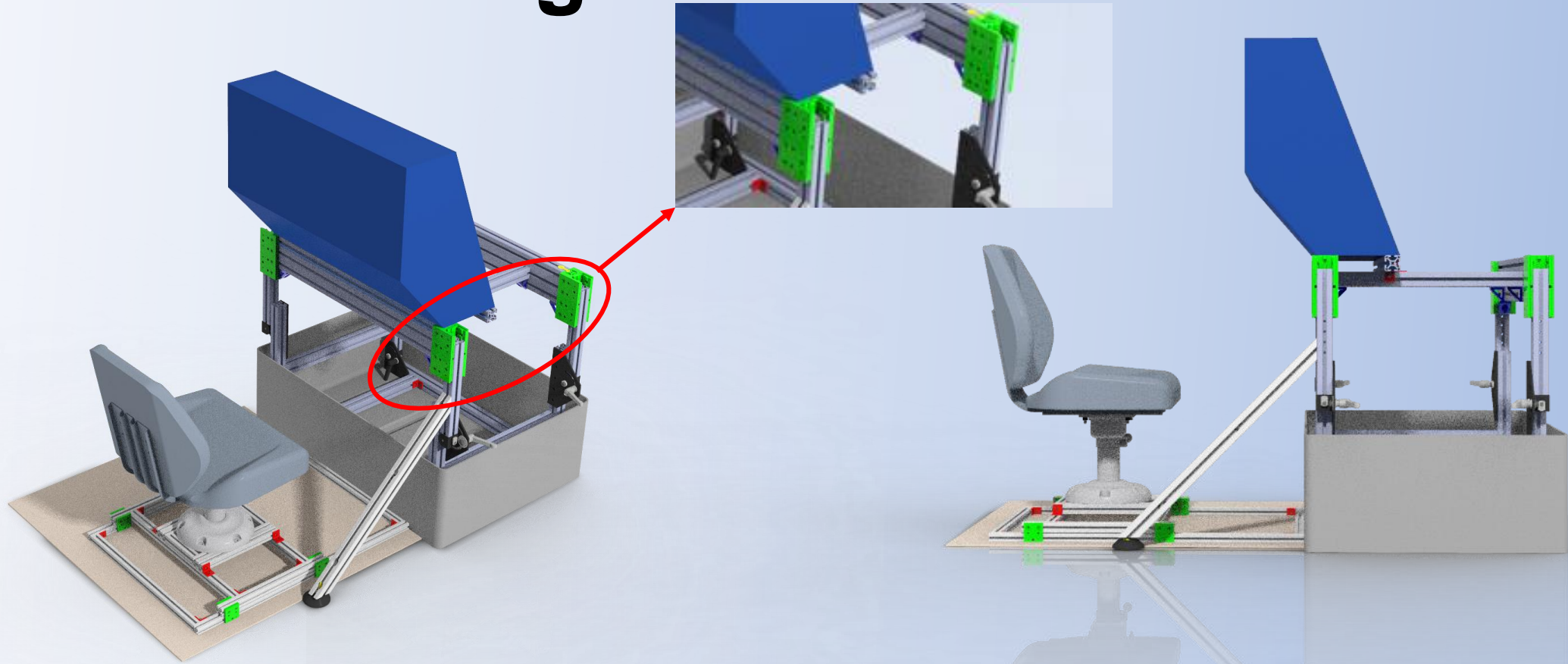

Christian Gonzalez

Simulator Mount – Top Level

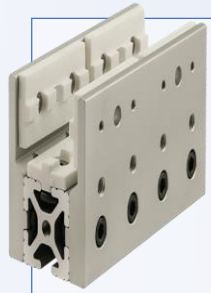

Long - Single Mount Uni-bearing™ Assembly

- This mechanism provide linear motion and the ability to hold heavy duty weight

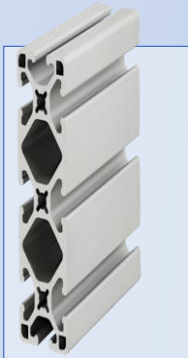

1545-8020-Light Weight and Smooth

- This bar help prevent deflection causing by applying force on the perpendicular to it



“T” Handle Linear Bearing Brake Kit

- This mechanism add adjustable stop and permanent security to a linear bearing

Kemuel Nelson

Seat Design

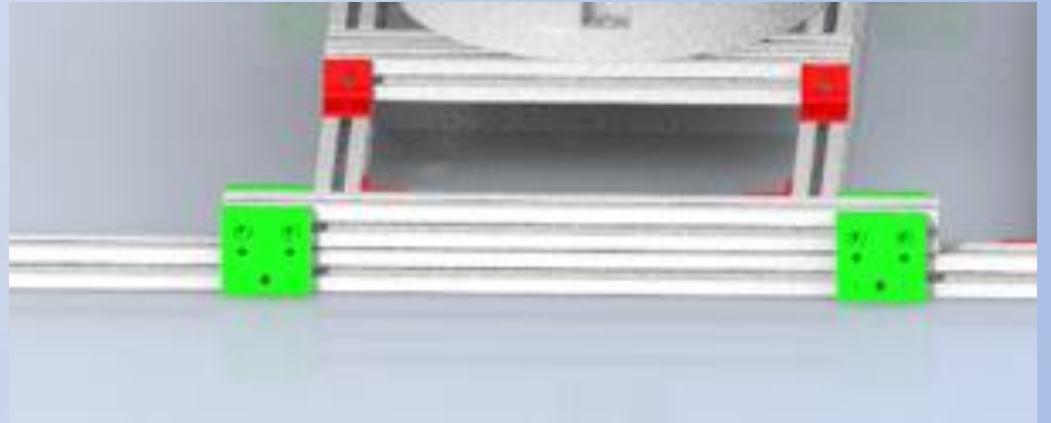
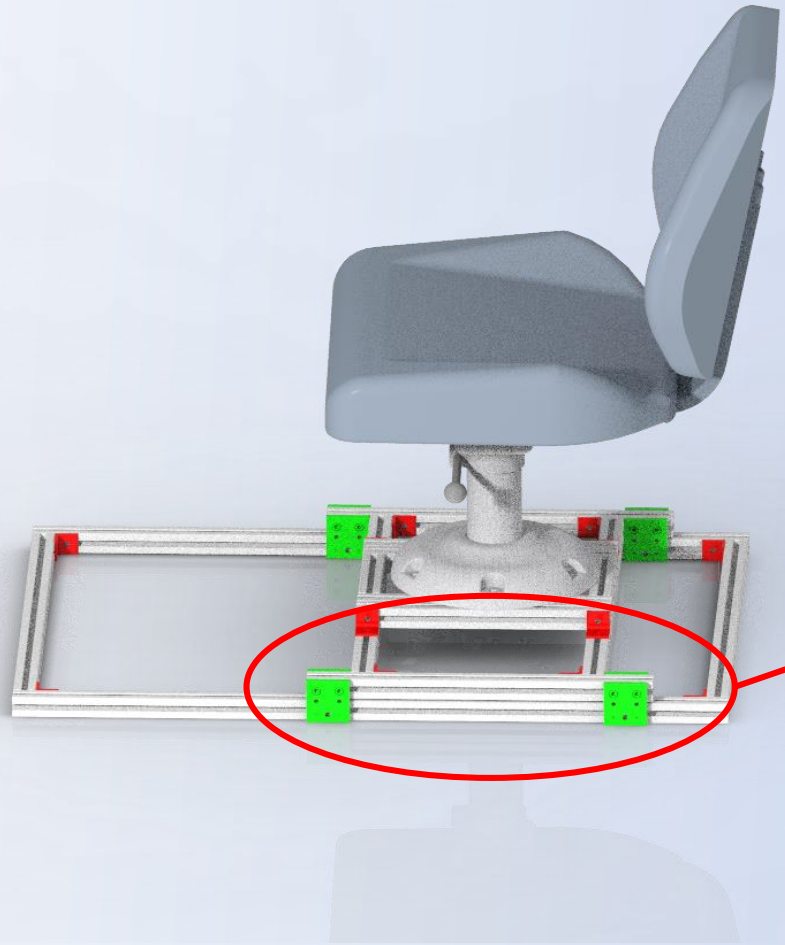

Kemuel Nelson

Frame



Single short Uni-Bearing

- This mechanism allow one bar to be secure in place while another is sliding



"L" handle Linear Bracket

- This mechanism add adjustable stop and security to permanent position



Double-keyed Uni-Bearing

- This mechanism prevent two metal rubbing against each other while sliding

Kemuel Nelson

Seat Design

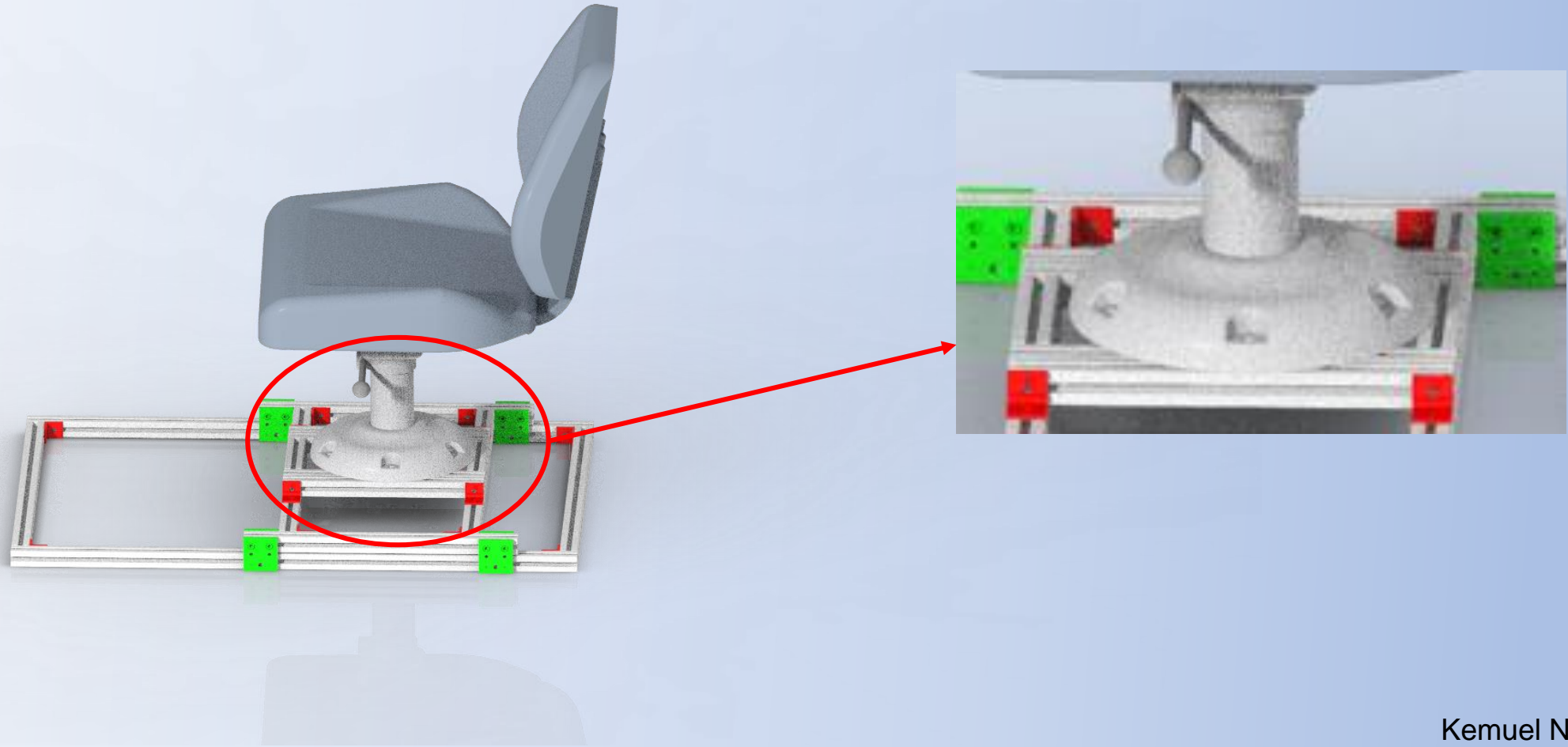

Kemuel Nelson

Mid-level to Seat



Boat Seat Adjustable Height Pedestal

- This mechanism allow the seat to be adjusted between 12-16 in

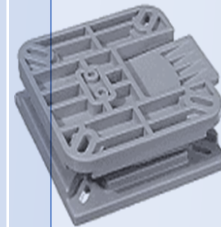

Quick-Release Seat Swivel

- This mechanism allow the seat to rotate 360 degree and detach the seat from the



Tournament Pro Lo-Back Boat Seat

- This mechanism provide the surface area in which an individual can seat

Kemuel Nelson

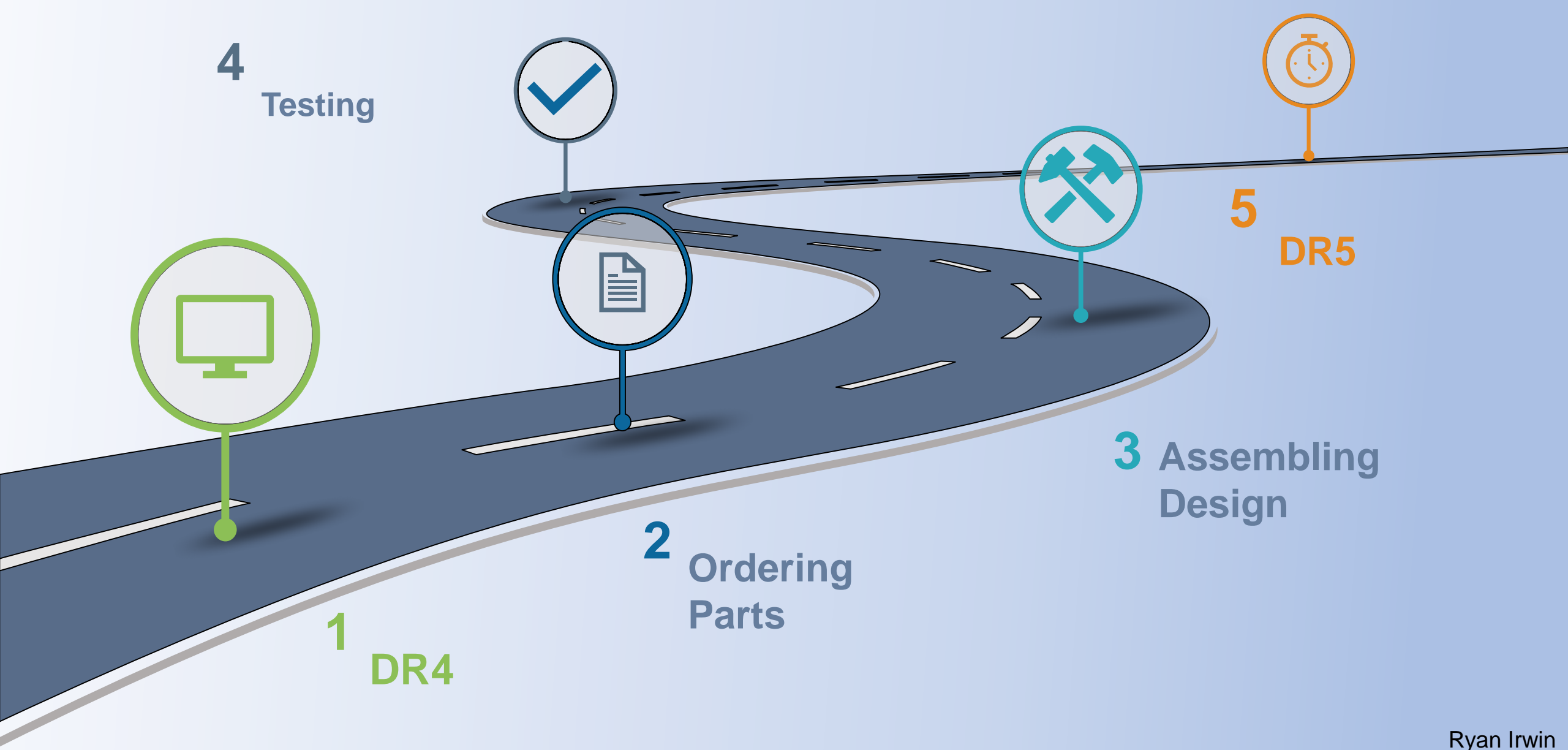

Ryan Irwin

Future Work

- Once all parts have been received and the design has been assembled, testing will be carried out in the senior design lab
- A load will be applied incrementally to the simulator mount, up to 60 pounds
- A force of 0.125 pounds will be applied to the top of the simulator, and the deflection will be measured
- A load will be applied incrementally to the seat, up to 214 pounds
- Participants will be asked to assemble and disassemble the design, and the time will be measured

References

- Lockheed Martin. (2015). Advanced Gunnery Training System. Retrieved from https://www.lockheedmartin.com/content/dam/lockheed-martin/rms/documents/advanced-gunnery-training-system/AGTS_Product%20Card_2015.pdf
- PowerPoint Templates and Themes: PPT Slide Templates: PowerPoint Slide Designs: Presentation Backgrounds: PPT Icon. (n.d.). Retrieved from <https://www.slidegeeks.com/>.
- Pike, J. (n.d.). Advanced Gunnery Training System. Retrieved from <https://www.globalsecurity.org/military/library/policy/army/fm/17-12-7/ch5.htm>

Contact Information

- **Ryan Irwin**
- rwi15@my.fsu.edu
- **Kemuel Nelson**
- kjn16@my.fsu.edu
- **Jarrold Darrow**
- jld15b@my.fsu.edu
- **Christian Gonzalez**
- cgg15b@my.fsu.edu

**“The Pessimist Sees
Difficulty In Every
Opportunity. The Optimist
Sees Opportunity In Every
Difficulty.” – Winston
Churchill**

Lockheed Martin has different Advanced Gunnery Training Systems (AGTS) which the military uses for training exercises. The goal of this project is to improve their tabletop module. Our Deployable Ground Vehicle Training Simulator looks to make the tabletop module from Lockheed Martin portable. The customer, Lockheed Martin, has two main problems with their current tabletop module. The problems are that it isn't stable enough when connected to some tables, like plastic folding tables and the user has to find their own chair. Our design has an adjustable simulator mount and chair that has enough stiffness and stability.

Our team obtained the product functions and requirements to design toward by talking to the customer. Consistent performance with each use was our main goal when we came up with different ideas for the design. After running the tests on CAD software, the final design is then tested to make sure all the functions are fulfilled. Our product aims to be portable, easy-to-use, and sturdy with the goal of making it more convenient for the user.