

Mobile Anechoic Chamber

Senior Design Team 506

Nicholas Ajhar, Marissa Jackson, Bryce Lankford

FAMU-FSU College of Engineering

Table of Contents

Introduction	3
Part Descriptions	3
Assembled Drawing.....	6
Assembly.....	6
Disassembly.....	11
Testing	11
Troubleshooting.....	12

Introduction

Danfoss Turbocor facility in Tallahassee, FL is responsible for the assembly of compressors for HVAC systems. They currently test the compressors before they are shipped to the customers with various specifications found during testing. One of these specifications that they have tested for is sound pressure (decibels). Although they have recorded sound, the measurement they have recorded is a measurement that varies with distance from the compressor. Danfoss has tasked team 506 with designing a method to record sound power (Watts), which is consistent no matter the distance from the compressor, and compatible with their current test stand. This operation manual contains information on various part numbers in the design, assembly and installation of the design on the test stand, mobility of design between load/unload of compressor and the recording position, as well as a testing procedure to record sound power. If any emergency arises that is not addressed in this operations manual, then emergency services should be contacted.

Part Descriptions

SD506001 – PCB 0.5” Microphone, Qty. 2

Description: Pressure transducers from PCB Piezoelectronics that detect acoustic pressure waves with a sensitivity of 10 mV/Pa. This outputs a voltage through a BNC cable that can be used with a DAQ system to convert to decibels.

SD506002 – Digital ICB/USB Signal Conditioner, Qty. 1

Description: Signal Conditioner/DAQ system that has 2 BNC inputs to connect to microphones that record acoustic pressure waves and converts to decibels. The data is then outputted into a computer via a USB port.

SD506003 – BNC Cable, Qty. 2

Description: Cable used to connect the microphones to the DAQ system that have a length of 6 feet.

SD506004 – Sleeve Bearing Carriage, Qty. 2

Description: When used on a rail system allows for the design to move between positions on the rail way.

SD506005 – Guide Rail, Qty. 2

Description: Rail system for the sleeve bearing carriage to slide on. This measures out to 250 mm (9.84 in) in total length.

SD506006 – M5 Fastener, Qty. 4

Description: Flat nuts to bolt the guide rail for the sleeve bearing carriage to the 80/20 post on Danfoss test stand

SD506007 – Microphone Clip, Qty. 2

Description: Clip onto the microphones to hold in a secure place

SD506008 – M4 Fastener, Qty. 4

Description: Bolts the microphone bracket to the sleeve bearing carriage.

SD506009 – 3/8-16 Bolt, Qty. 5

Description: This bolt is used to bolt into the microphone clip and attach to the microphone bracket.

SD506010 – Rubber Grommet, Qty. 5

Description: Pressed into holes into the microphone bracket to allow a flush connection between the bolts and microphone bracket.

SD506011 – 3/8-16 Nut, Qty. 5

Description: This nut is used to secure the 2/8-16 bolt to the microphone bracket.

SD506012 – Wire Clamp, Qty. 5

Description: U-clamp to hold BNC wire close to the microphone bracket.

SD506013 – 1/4-20 Bolt, Qty. 5

Description: This bolts the wire clamp to the microphone bracket.

SD506014 – 1/4-20 Nut, Qty. 5

Description: This secures the bolt that holds the wire clamp to the microphone bracket.

SD506015 – M5 Bolt, Qty. 4

Description: This bolt is used to attach the guide rail for the sleeve carriage to the 80/20 post.

SD506016 – M5 Nut, Qty. 4

Description: This nut is used on top of the guide rail for the sleeve carriage to secure the guide rail in place.

SD506017 – Microphone Bracket, Qty. 1

Description: The microphone bracket has a constant radius throughout of 37 inches. It is a single welded part that is used to hold the microphones in place over the compressor by through holes that the 3/8-16 bolts are pressed through. It also has flat plates welded to the ends to attach to the sleeve carriage to allow for mobility.

Assembled Drawing

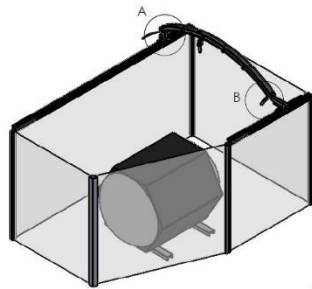

ITEM NO.	PART NUMBER	DESCRIPTION	QTY.
1	SD506005	Guide Rail	2
2	SD506004	Sleeve Bearing Carriage	2
3	SD506015	M5 Bolt	4
4	SD506001	PCB 0.5" Microphone	2
5	SD506012	Wire Clamp	5
6	SD506017	Microphone Bracket	1
7	SD506009	3/8-16 Bolt	5
8	SD506010	Rubber Grommet	5
9	SD506008	M4 Fastener	8
10	SD506013	1/4-20 Bolt	5
11	SD506007	Microphone Clip	2
12	SD506003	BNC Cable	2

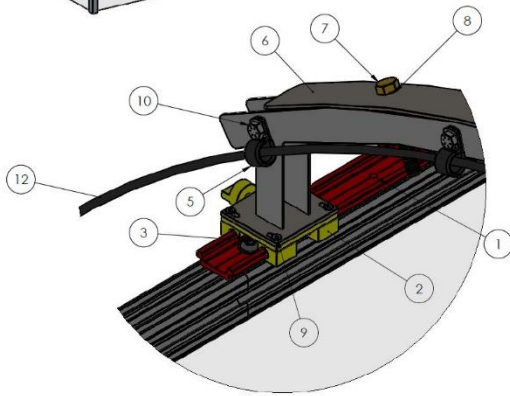

DETAIL A
SCALE 1 : 2

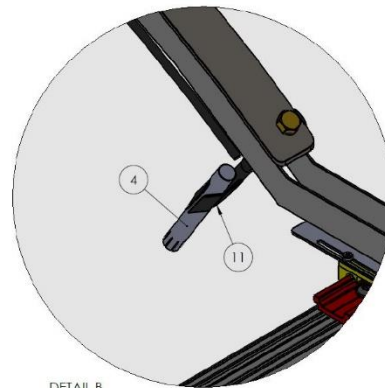

DETAIL B
SCALE 1 : 2

Figure 1. Assembled drawing with bill of materials

Assembly

- 1) Place flat nut (M5 fastener SD506006) in center rail of 80/20 post.

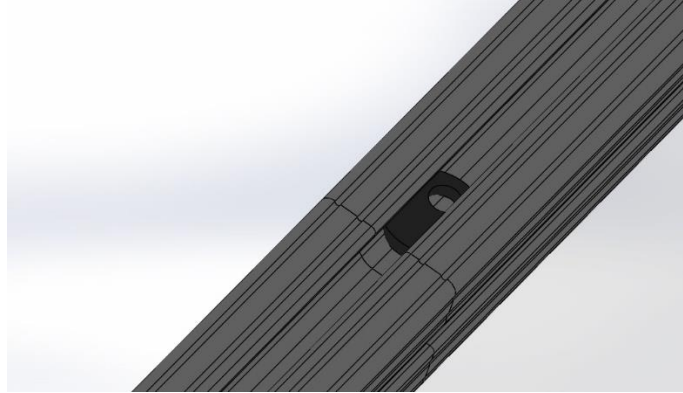

Figure 2. Flat nut inside of 80/20 post

- 2) Place bracket on test stand with guide rails centered on 80/20 post with holes of guide rail lined up with flat nut (M5 fastener).



Figure 3. Left side of microphone bracket flush with 80/20 post



Figure 4. Right side of microphone bracket flush with 80/20 post

- 3) Place M5 bolt (SD506016) through hole and ensure the nut starts threading on bolt. Once started repeat process for the 4 other M5 bolts on the outside holes of the rail guide.

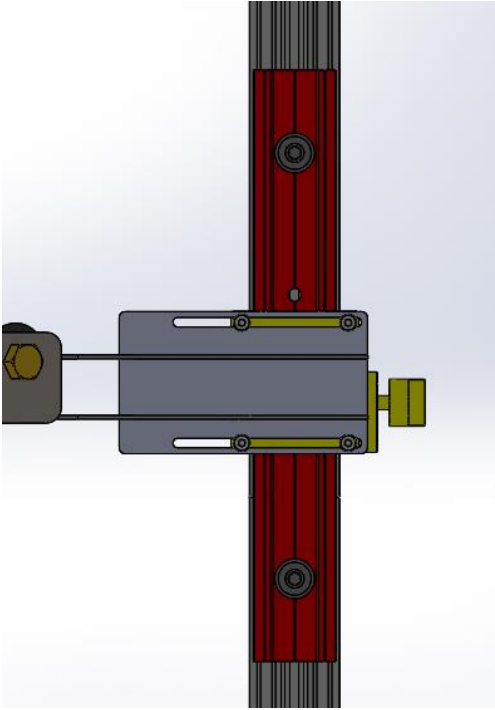

Figure 5. M5 Fasteners on a single rail guide

- 4) Tighten M5 bolt (SD506015) enough to ensure that the M5 fastener (SD506006) is flush with inside of 80/20 post.

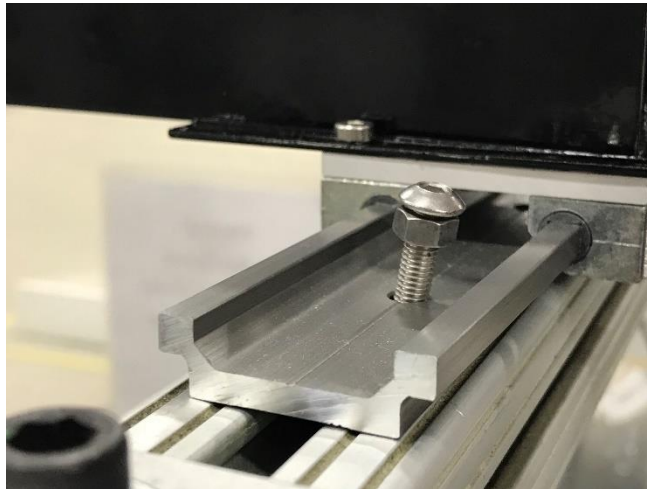

Figure 6. M5 bolt (SD506015) with M5 fastener (SD506006) tightened underneath

- 5) Tighten the M5 nut (SD506016) so the nut is flush with the top of the rail guide (SD506005).

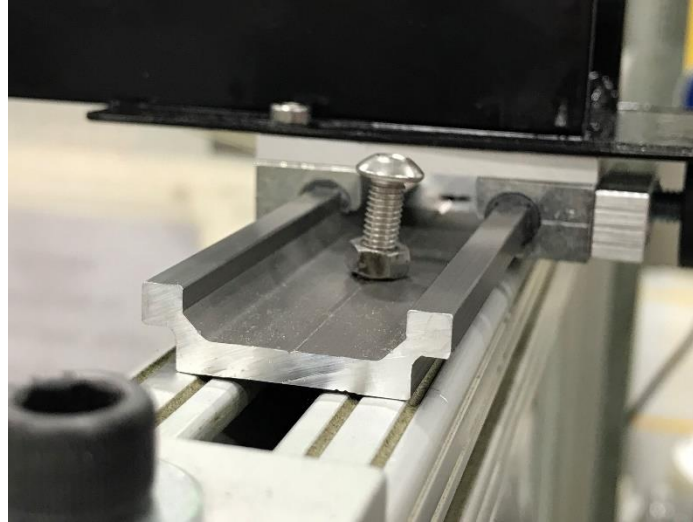

Figure 7. M5 nut (SD56016) tightened until flush with rail guide (SD56005)

- 6) Repeat steps 4 and 5 for the remaining 3 M5 bolts (SD56015)
- 7) Plug BNC cables (SD56003), if not already, into microphones (SD56001)



- 8) Plug BNC cables (SD56003) into DAQ system (SD56002) BNC inputs



9) Plug DAQ system (SD506002) USB output into computer



10) Slide microphone bracket (SD506017) to the marked loading/unloading position to load compressor into the test stand

11) Once compressor is loaded into the test stand slide microphone bracket (SD506017) to the marked testing position



Figure 11. Microphone bracket (SD506017) secured in position over test station

Disassembly

- 1) Unplug DAQ system (SD506002) USB output from computer
- 2) Unplug BNC cables (SD506003) from the DAQ system (SD506002) BNC inputs
- 3) Loosen M5 nut (SD506016) that is flush with the rail guide all the way until the top of the nut is flush with the head of the M5 bolt (SD506015)
- 4) Turn the M5 bolt (SD506015) counter clockwise to loosen the M5 fastener (SD506006) until it falls into 80/20 post
- 5) Remove the microphone bracket (SD506017) from the test station with the sleeve carriage (SD506004) still attached to the guide rail (SD506005)
- 6) Using needle nose pliers remove the M5 fastener (SD506006) from the 80/20 post

Testing

- 1) Open MATLAB program labeled *“Sound_power_testing”*
- 2) Ensure time of recording in editor is of desired length (This is commented on the side with *“time of recording”*)
- 3) When recording is desired to start under the editor tab press *“Run”*. If recording is needed to stop press *“Pause”* on the editor tab in MATLAB
- 4) Once recording is finished the sound power results will be saved under the variable *“Sound power”*

Troubleshooting

- If any of the microphones were to become damaged or inoperable, a reorder of the microphone should be implemented. If microphones are to be replaced, the microphone bracket should be taken off the testing stand to do so following the disassembly section in this operation manual
- If the DAQ system were to be damaged or inoperable, a reorder of the DAQ system should be implemented
- If a microphone were to fall out of the microphone clip, the testing should be paused and power to the compressor should be turned off. Once power is off, the microphone should be reinserted into the microphone clip
- If a microphone clip were to break, a reorder should be implemented for the microphone clip
- If a wire clamp (SD506012) were to break, this should be replaced while the microphone bracket is off the testing station. If the microphone bracket is on the testing station, follow the disassembly section in this operation manual
- If any errors in the conversion program are present use debugging tool in MATLAB or contact MATLAB support