



Mobile GPS Payload

Virtual Design Review 2

Michael Connell

Ricky Gal

Raine Sagramsingh



Introduction

Taylor Davis
Administrative Lead

Raine Sagramsingh
Sponsor Liaison



Michael Connell
ME Lead

Travis Bruner
Webmaster & Financial
Lead

Ricky Gal
ECE Lead



Project Brief

- Sponsor:
 - Space Vehicles Directorate, Air Force Research Lab (AFRL) – Advanced GPS Technologies Program (AGT)



- Design a mobile GPS lab with the capability to test components of a position, navigation, and timing payload.
 - cost effective
 - user friendly
 - as simple as possible



Target Summary

Customer Need	Target
The mobile lab is technician friendly.	Interior temperature of 68-77°F
The lab has workstations for multiple operators.	Accommodate 1-3 test operators
Lab equipment functions inside of the vehicle.	Equipment runs at 32-104°F
The unit holds varying sizes of equipment.	Storage for racks of heights up to 6'
The unit is self-sufficient.	Provides at least 6kW of power
	Runs for 55 hours without recharge
The vehicle withstands various environments.	Can withstand up to 75 mph winds
Operators have access to a restroom on site.	Restroom within 5 min. drive
The design provides a reasonably priced option.	Non-recurring costs: ~\$150,000
The design minimizes operational costs.	Each deployment: < \$2,500



Target Summary

Customer Need	Target
The mobile lab is technician friendly.	Interior temperature of 68-77°F
The lab has workstations for multiple operators.	Accommodate 1-3 test operators
Lab equipment functions inside of the vehicle.	Equipment runs at 32-104°F
The unit holds varying sizes of equipment.	Storage for racks of heights up to 6'
The unit is self-sufficient.	Provides at least 6kW of power
	Runs for 55 hours without recharge
The vehicle withstands various environments.	Can withstand up to 75 mph winds
Operators have access to a restroom on site.	Restroom within 5 min. drive
The design provides a reasonably priced option.	Non-recurring costs: ~\$150,000
The design minimizes operational costs.	Each deployment: < \$2,500



Target Summary

Customer Need	Target
The mobile lab is technician friendly.	Interior temperature of 68-77°F
The lab has workstations for multiple operators.	Accommodate 1-3 test operators
Lab equipment functions inside of the vehicle.	Equipment runs at 32-104°F
The unit holds varying sizes of equipment.	Storage for racks of heights up to 6'
The unit is self-sufficient.	Provides at least 6kW of power
	Runs for 55 hours without recharge
The vehicle withstands various environments.	Can withstand up to 75 mph winds
Operators have access to a restroom on site.	Restroom within 5 min. drive
The design provides a reasonably priced option.	Non-recurring costs: ~\$150,000
The design minimizes operational costs.	Each deployment: < \$2,500



Target Summary

Customer Need	Target
The mobile lab is technician friendly.	Interior temperature of 68-77°F
The lab has workstations for multiple operators.	Accommodate 1-3 test operators
Lab equipment functions inside of the vehicle.	Equipment runs at 32-104°F
The unit holds varying sizes of equipment.	Storage for racks of heights up to 6'
The unit is self-sufficient.	Provides at least 6kW of power
	Runs for 55 hours without recharge
The vehicle withstands various environments.	Can withstand up to 75 mph winds
Operators have access to a restroom on site.	Restroom within 5 min. drive
The design provides a reasonably priced option.	Non-recurring costs: ~\$150,000
The design minimizes operational costs.	Each deployment: < \$2,500



Target Summary

Customer Need	Target
The mobile lab is technician friendly.	Interior temperature of 68-77°F
The lab has workstations for multiple operators.	Accommodate 1-3 test operators
Lab equipment functions inside of the vehicle.	Equipment runs at 32-104°F
The unit holds varying sizes of equipment.	Storage for racks of heights up to 6'
The unit is self-sufficient.	Provides at least 6kW of power
	Runs for 55 hours without recharge
The vehicle withstands various environments.	Can withstand up to 75 mph winds
Operators have access to a restroom on site.	Restroom within 5 min. drive
The design provides a reasonably priced option.	Non-recurring costs: ~\$150,000
The design minimizes operational costs.	Each deployment: < \$2,500



Target Summary

Customer Need	Target
The mobile lab is technician friendly.	Interior temperature of 68-77°F
The lab has workstations for multiple operators.	Accommodate 1-3 test operators
Lab equipment functions inside of the vehicle.	Equipment runs at 32-104°F
The unit holds varying sizes of equipment.	Storage for racks of heights up to 6'
The unit is self-sufficient.	Provides at least 6kW of power
	Runs for 55 hours without recharge
The vehicle withstands various environments.	Can withstand up to 75 mph winds
Operators have access to a restroom on site.	Restroom within 5 min. drive
The design provides a reasonably priced option.	Non-recurring costs: ~\$150,000
The design minimizes operational costs.	Each deployment: < \$2,500



Target Summary

Customer Need	Target
The mobile lab is technician friendly.	Interior temperature of 68-77°F
The lab has workstations for multiple operators.	Accommodate 1-3 test operators
Lab equipment functions inside of the vehicle.	Equipment runs at 32-104°F
The unit holds varying sizes of equipment.	Storage for racks of heights up to 6'
The unit is self-sufficient.	Provides at least 6kW of power
	Runs for 55 hours without recharge
The vehicle withstands various environments.	Can withstand up to 75 mph winds
Operators have access to a restroom on site.	Restroom within 5 min. drive
The design provides a reasonably priced option.	Non-recurring costs: ~\$150,000
The design minimizes operational costs.	Each deployment: < \$2,500



Target Summary

Customer Need	Target
The mobile lab is technician friendly.	Interior temperature of 68-77°F
The lab has workstations for multiple operators.	Accommodate 1-3 test operators
Lab equipment functions inside of the vehicle.	Equipment runs at 32-104°F
The unit holds varying sizes of equipment.	Storage for racks of heights up to 6'
The unit is self-sufficient.	Provides at least 6kW of power
	Runs for 55 hours without recharge
The vehicle withstands various environments.	Can withstand up to 75 mph winds
Operators have access to a restroom on site.	Restroom within 5 min. drive
The design provides a reasonably priced option.	Non-recurring costs: ~\$150,000
The design minimizes operational costs.	Each deployment: < \$2,500



Target Summary

Customer Need	Target
The mobile lab is technician friendly.	Interior temperature of 68-77°F
The lab has workstations for multiple operators.	Accommodate 1-3 test operators
Lab equipment functions inside of the vehicle.	Equipment runs at 32-104°F
The unit holds varying sizes of equipment.	Storage for racks of heights up to 6'
The unit is self-sufficient.	Provides at least 6kW of power
	Runs for 55 hours without recharge
The vehicle withstands various environments.	Can withstand up to 75 mph winds
Operators have access to a restroom on site.	Restroom within 5 min. drive
The design provides a reasonably priced option.	Non-recurring costs: ~\$150,000
The design minimizes operational costs.	Each deployment: < \$2,500



Concept Generation

1. Vehicle selection:
 - a. Motorhome
 - b. Camper Trailer
 - c. Enclosed Trailer
 - d. Shipping Container
 - e. Step Van

2. Interior Floor Plan
 - a. 3 different plans
 - b. Based off of Kitchen Work Triangle concept

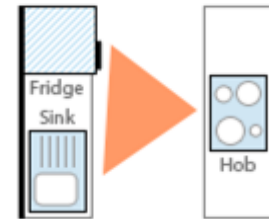

Galley

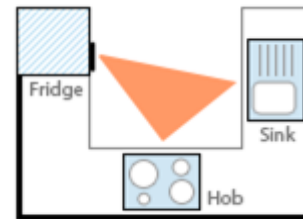

U-shaped

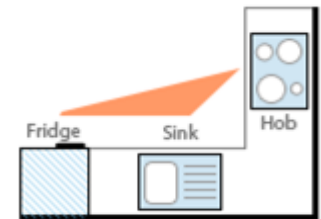

L-shaped



Michael Connell

Vehicle Concepts



FAMU-FSU COLLEGE OF ENGINEERING
MECHANICAL ENGINEERING

Ricky Gal

Concept 1 - Motorhome

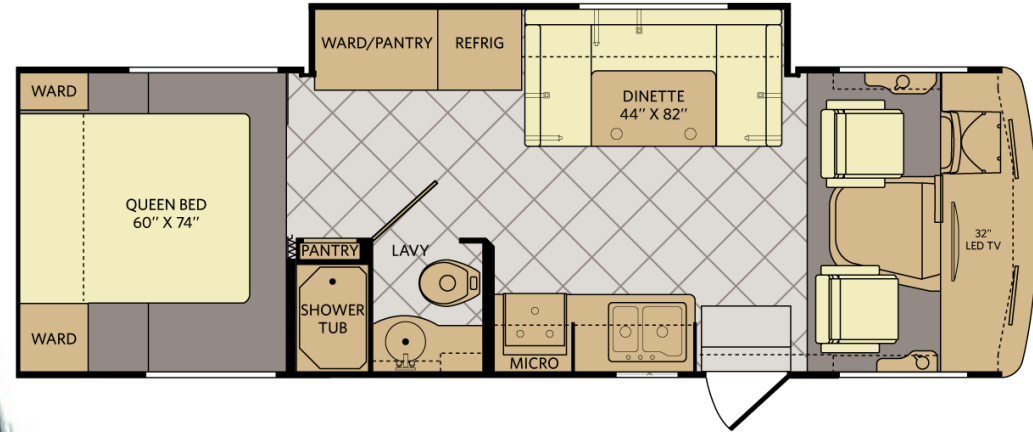

Class A: \$80,000+

Concept	Interior temp	Restroom	1-3 operators	Storage of racks up to 6'	Overall cost of \$150,000	Deployment cost of \$2,500
Motor Home	X	X	X	X	X	X



Concept 1 - Motorhome

PROS:

- Meets all targets
- Models come standard with:
 - Restroom
 - HVAC
 - Generator
- Toy hauler models have a ramp for easy loading
- All inclusive
 - No need for a separate tow vehicle
- Low deployment cost

CONS:

- Highest initial cost
- Regular maintenance associated with an automobile



Concept 2 - Camper Trailer

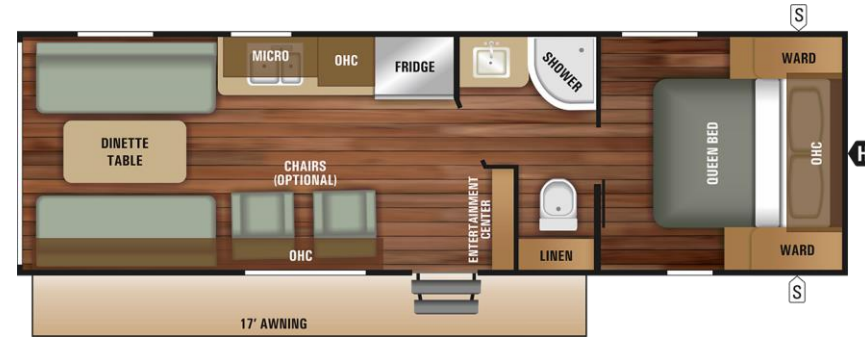

Cost: \$10,000+

Concept	Interior temp	Restroom	1-3 operators	Storage of racks up to 6'	Overall cost of \$150,000	Deployment cost of \$2,500
Camper Trailer	X	X	X	X	X	X



Concept 2 - Camper Trailer

PROS:

- Meets all targets
- Models come standard with:
 - Restroom
 - HVAC
 - Generator
- Toy hauler models have a ramp for easy loading
- Low deployment cost
- No regular automobile maintenance
 - Tow vehicle rental

CONS:

- Higher initial cost
- Separate tow vehicle required



Concept 3 - Enclosed Trailer

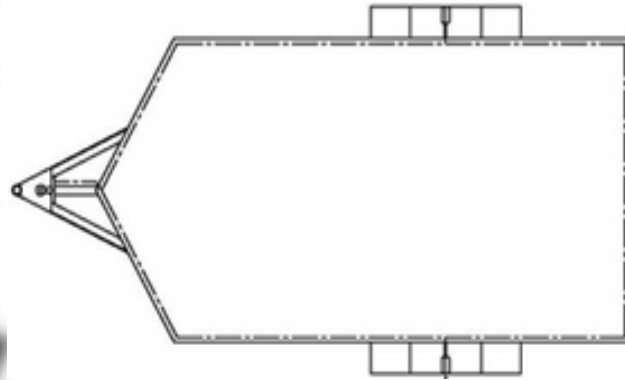

Cost: \$1,200 - \$30,000

Concept	Interior temp	Restroom	1-3 operators	Storage of racks up to 6'	Overall cost of \$150,000	Deployment cost of \$2,500
Enclosed Trailer	(mod)	(mod)	X	X	X	X



Concept 3 - Enclosed Trailer

PROS:

- Can meet all targets
 - Needs modifications
- Comes standard with a loading ramp
- Some models have HVAC
- Easily customizable option
- Inexpensive to purchase standard model
- Low deployment cost
- No regular automobile maintenance

CONS:

- A tow vehicle is required
- Requires more labor costs to meet all targets



Concept 4 - Shipping Container

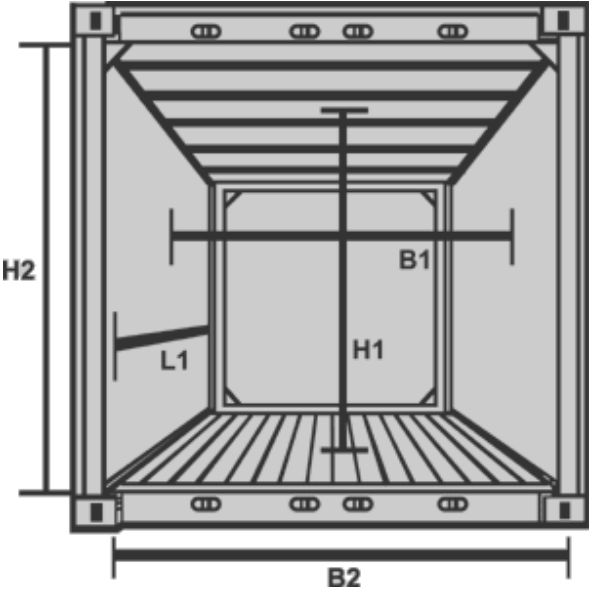

Cost: \$3,000 - \$7,000

Concept	Interior temp	Restroom	1-3 operators	Storage of racks up to 6'	Overall cost of \$150,000	Deployment cost of \$2,500
Shipping Container	(mod)	(mod)	X	X	X	X



Concept 4 - Shipping Container

PROS:

- Can meet all targets
 - Needs modifications
- Easily customizable option
- Inexpensive before modifications
- There are companies that specialize in shipping container mods

CONS:

- An expensive transport vehicle is required
- Requires more labor costs to meet all targets
- Limited sizing options



Concept 5 - Step Van

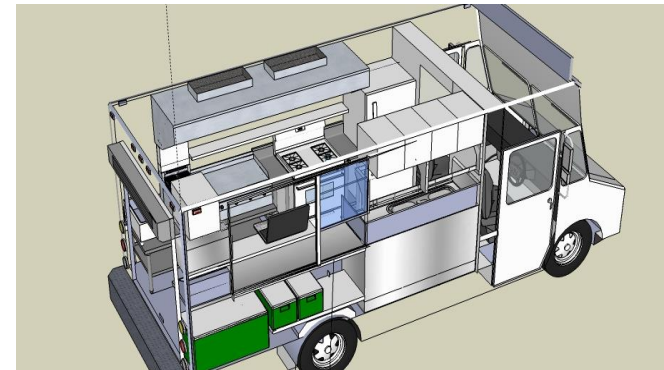
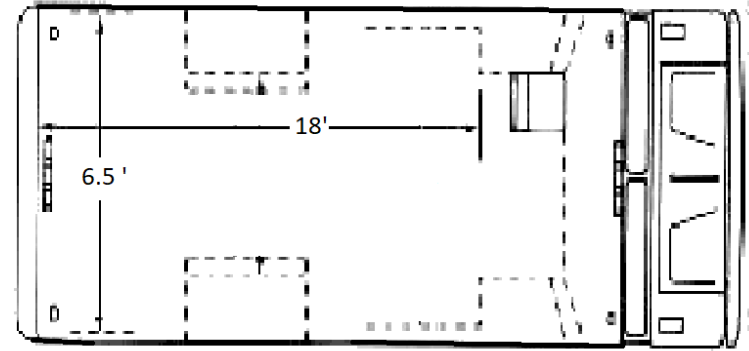

Cost: \$50,000 - \$70,000

Concept	Interior temp	Restroom	1-3 operators	Storage of racks up to 6'	Overall cost of \$150,000	Deployment cost of \$2,500
Step Van	(mod)	(mod)	X	X	X	X



Concept 5 - Step Van

PROS:

- Can meet all targets
 - Needs modifications
- Some models have HVAC
- Easily customizable option
- All inclusive
 - Self Propelled

CONS:

- Requires more labor costs to meet all targets
- Regular automotive maintenance and repairs
- Limited seating while in transit



Raine Sagramsingh

Interior Floor Plan Concepts



FAMU-FSU COLLEGE OF ENGINEERING
MECHANICAL ENGINEERING

Michael Connell

Interior Floor Plan

➤ Designed for 3 operators with 2 racks of equipment

1. Blue Operator

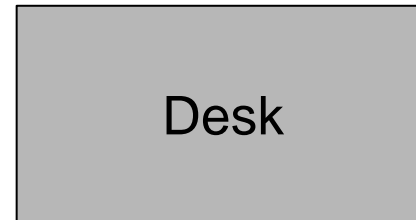

2. Yellow Operator



Seated Position

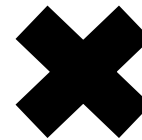

Reach Radius

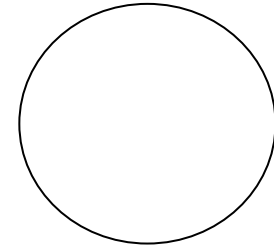

3. Green Operator



Walking Path



Interior Floor Plan 1

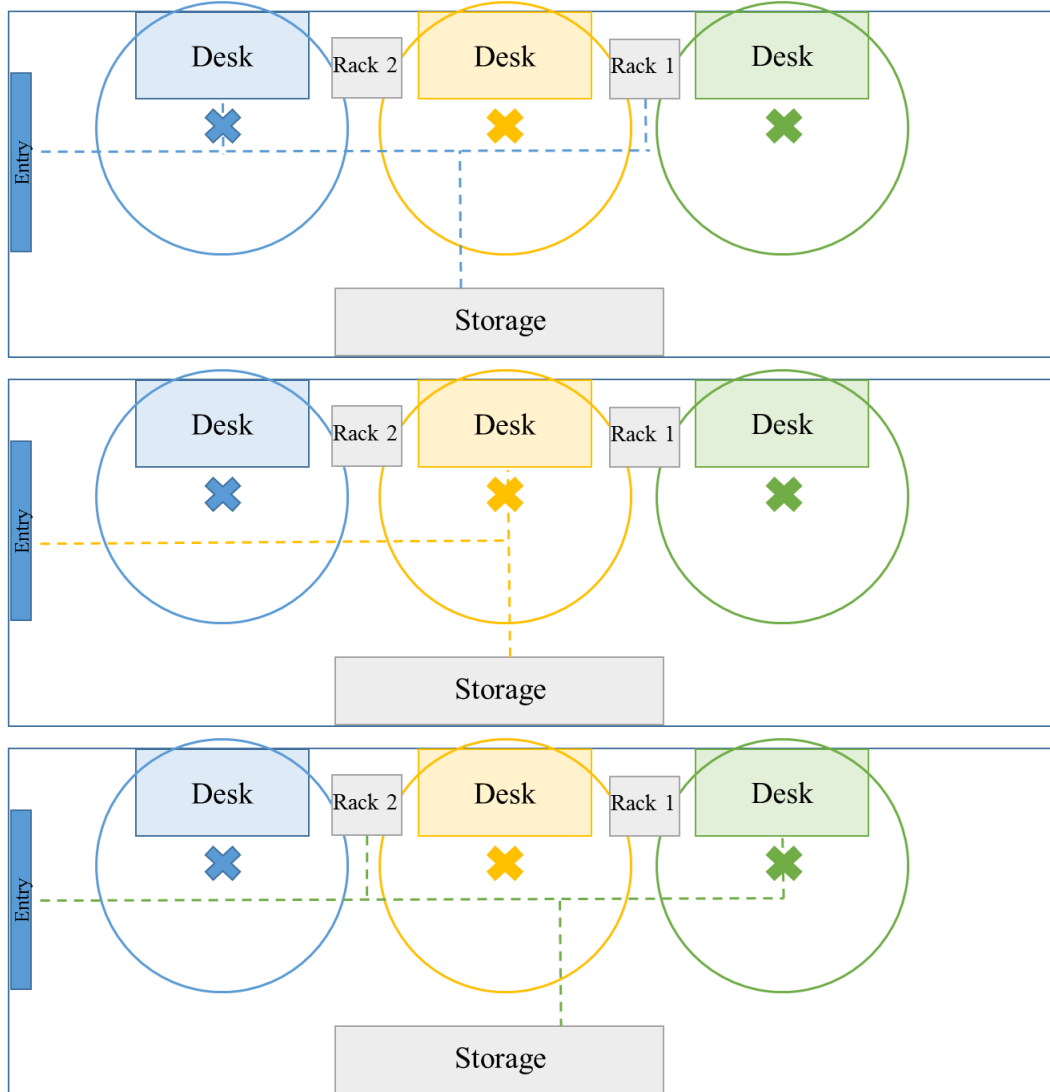

- Blue operator:
 - Primary: Rack 2
 - Occasional movement to Rack 1
- Yellow operator:
 - Access to both racks
- Green operator:
 - Primary: Rack 1
 - Occasional movement to Rack 1



Interior Floor Plan 2

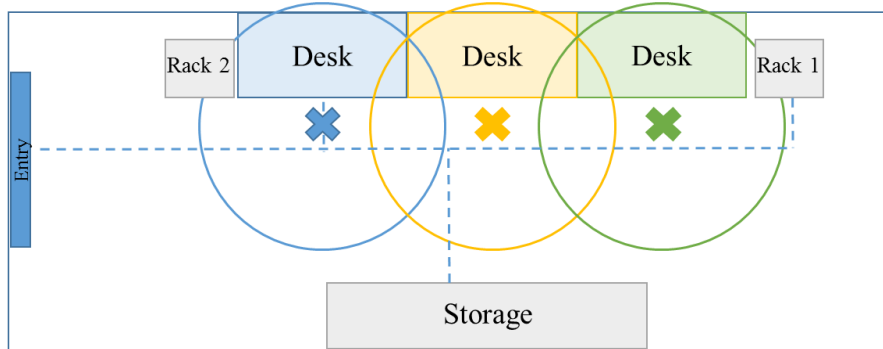

- Blue operator:
 - Primary: Rack 2
 - Occasional movement to Rack 1

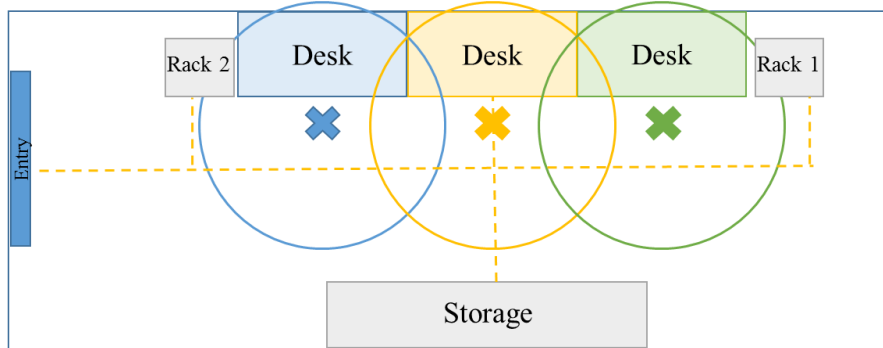

- Yellow operator:
 - Frequent movement to Rack 1
 - Occasional movement to Rack 2

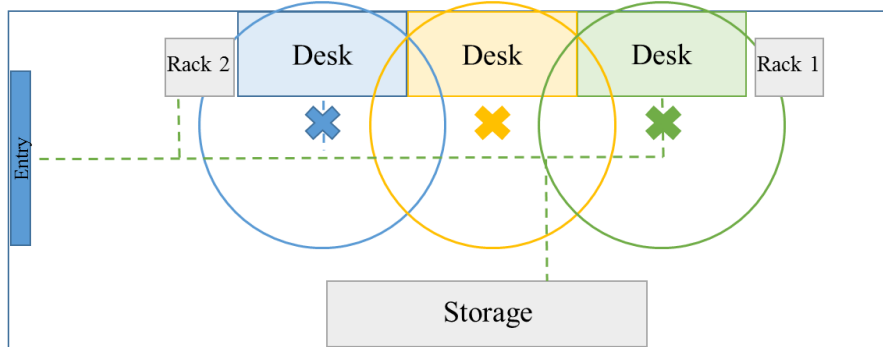

- Green operator:
 - Primary: Rack 1
 - Occasional movement to Rack 2



Interior Floor Plan 3

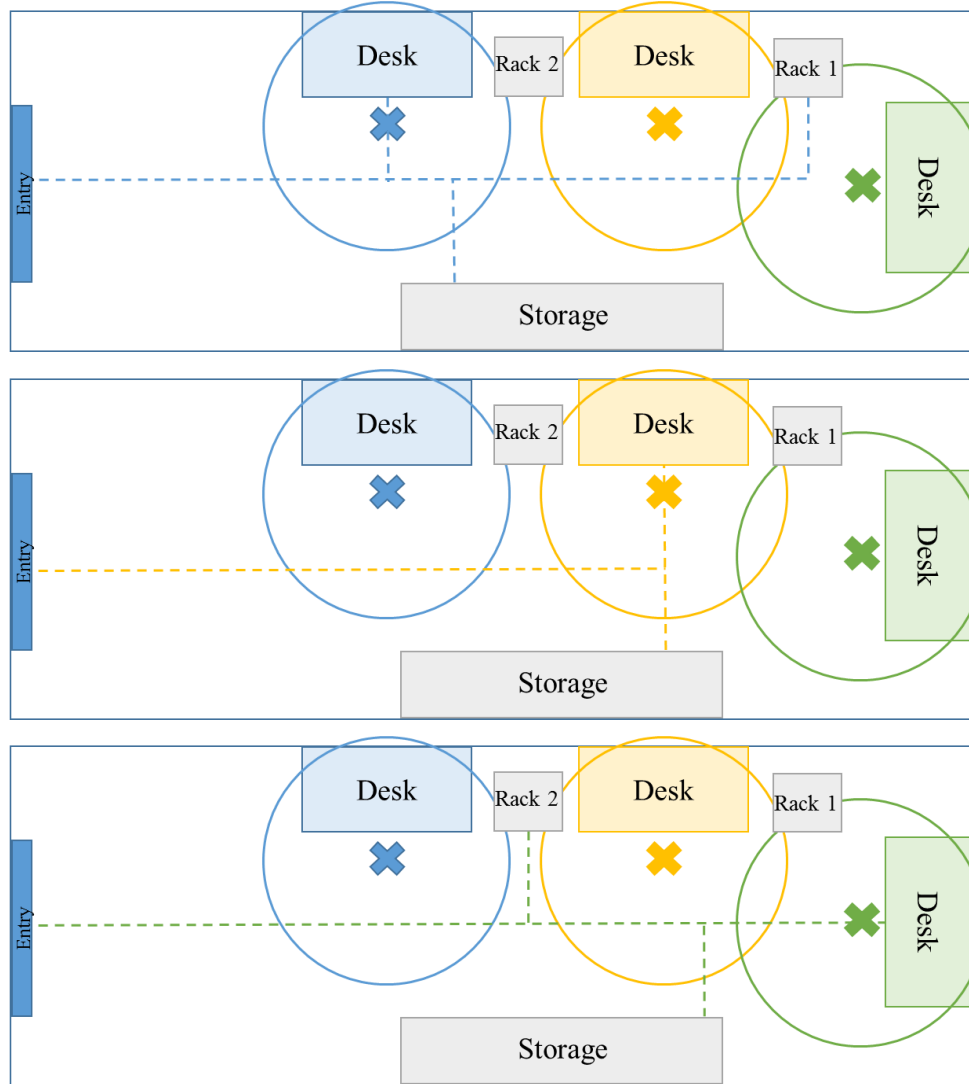

- Blue operator:
 - Primary: Rack 2
 - Occasional movement to Rack 1
- Yellow operator:
 - Access to both racks
- Green operator:
 - Primary: Rack 1
 - Occasional movement to Rack 2



Ricky Gal

Next Steps



Next Steps

- Vehicle Selection
- Interior will be fully designed after vehicle selection, taking into consideration:
 - Ergonomics
 - Efficiency
 - Weight distribution
 - Sponsor preference
- Project Plan
- Website



Questions?



FAMU-FSU COLLEGE OF ENGINEERING
MECHANICAL ENGINEERING

References

- Dieter, G. E., & Schmidt, L. C. (2012). *Engineering Design*. New York: McGraw-Hill Higher Education.
- Air Force Research Lab. (n.d.). Retrieved from <https://teamafrl.afciviliancareers.com/kitchens.com>. (n.d.). *The Work Triangle*. Retrieved from <http://www.kitchens.com/design/layouts/the-work-triangle/the-work-triangle>
- Keyserling, W., Punnett, L., & Fine, L.J. (n.d.) *Ergonomic Interventions to Prevent Musculoskeletal Injuries in Industry*. Lewis Publishers.
- Fleetwood RV. (n.d.) *Flair*. Retrieved November 01, 2017, from <http://www.fleetwoodrv.com/2018-fleetwood-flair>
- DiamondCargo.com (n.d.) Retrieved November 01, 2017, from <https://diamondcargo.com/>
- Pro-Line Trailers. (n.d.) *Enclosed Trailers & Cargo Trailers*. Retrieved November 01, 2017, from <https://www.prolinetrailersales.com/enclosed-trailers>
- Aztec Container. (n.d.) *40 Foot Storage and Shipping Containers with Cargo Doors*. Retrieved November 01, 2017, from <https://www.azteccontainer.com/storage-container-40ft-cargo-door.html>
- Shayne Oswald Shipping Consultants. (n.d.) *Container Specifications*. Retrieved November 01, 2017, from <http://www.sosconsultants.com.au/container-specifications>
- Expandable/Hybrid Campers, Travel Trailers & RVs. (n.d.) Retrieved November 01, 2017, from <https://starcraftrv.com/styles/expandable-hybrid/>
- The Lunch Truck Biz. (2013, February 10). Retrieved November 01, 2017, from <https://www.pinterest.com/pin/230809549624927720/>
- Chevrolet stepvan pictures & photos, information of modification (video) to Chevrolet stepvan on Details-of-cars.com. (2015, March 21). Retrieved November 01, 2017, from <http://details-of-cars.com/chevrolet-stepvan/>
- Parts that fit Morgan Olson Step Vans. (n.d.). Retrieved November 01, 2017, from http://www.stepvanparts.com/morgan_olson_stepvan.htm



Back-Up Slides



Acronyms

GPS	Global Positioning System
ME	Mechanical Engineering
ECE	Electrical/Computer Engineering
AFRL	Air Force Research Lab
AGT	Advanced GPS Technologies
HVAC	Heating, Ventilation and Air Conditioning
PNT	position, navigation, and timing



PNT Equipment

- High power amplifiers
- On-orbit Reprogrammable Digital Waveform Generators (ORDWG)
- New antenna concepts
- Supporting electronics
- Algorithms and new signal combining methods
- Satellite bus technologies for increased resiliency and lower Size, Weight, and Power (SWaP)
- Advanced cyber technology



Kitchen Work Triangle

- Defined by the National Kitchen and Bath Association:
 - An imaginary straight line drawn from the center of the sink, to the center of the cooktop, to the center of the refrigerator.
- Main goal: efficiency
 - keeps major work stations near the cook
 - minimizes traffic within kitchen
 - prevents kitchen from being cramped



Vehicle Concepts

Concept	Interior temp	Restroom	1-3 operators	Storage of racks up to 6'	Overall cost of \$150,000	Deployment cost of \$2,500
Motor Home	<input type="checkbox"/>	<input type="checkbox"/>	<input type="checkbox"/>	<input type="checkbox"/>	<input type="checkbox"/>	<input type="checkbox"/>
Camper Trailer	<input type="checkbox"/>	<input type="checkbox"/>	<input type="checkbox"/>	<input type="checkbox"/>	<input type="checkbox"/>	<input type="checkbox"/>
Enclosed Trailer	<input type="checkbox"/>	<input type="checkbox"/>	<input type="checkbox"/>	<input type="checkbox"/>	<input type="checkbox"/>	<input type="checkbox"/>
Shipping Container	<input type="checkbox"/>	<input type="checkbox"/>	<input type="checkbox"/>	<input type="checkbox"/>	<input type="checkbox"/>	<input type="checkbox"/>
Step Van	<input type="checkbox"/>	<input type="checkbox"/>	<input type="checkbox"/>	<input type="checkbox"/>	<input type="checkbox"/>	<input type="checkbox"/>

Legend:

- Can meet target with modification
- Meets target when purchased



Vehicle Concepts

- Some vehicle options do not meet all of the targets at the time of initial purchase, but all vehicles have ability to be modified to meet targets.
- When completing analysis to select vehicle, the team will consider:
 - vehicle cost
 - modification time and cost
 - labor time and cost



Reach Radius

- Term used in ergonomics
- Definition:
reach radius = upper arm + forearm + hand
- For horizontal reach, the 5th percentile female (151.1 cm) is used

