

FAMU-FSU College of Engineering  
Department of Mechanical Engineering

Team # 11  
Intelligent Ground Vehicle Competition

Sponsor: Northrop Grumman  
Advisor: Dr. Nikhil Gupta

**Names:**

**FAMU-FSU**

Ezekiel Copeland  
Justin Daniel  
Matthew Patton  
Andres Nodarse  
Tajaey Young

**Contact Email:**

[ebc13@my.fsu.edu](mailto:ebc13@my.fsu.edu)  
[jbd12b@my.fsu.edu](mailto:jbd12b@my.fsu.edu)  
[msp12b@my.fsu.edu](mailto:msp12b@my.fsu.edu)  
[aan12b@my.fsu.edu](mailto:aan12b@my.fsu.edu)  
[tajaey1.young@fam.u.edu](mailto:tajaey1.young@fam.u.edu)

**FIT**

Matthew Salferhobbs	<a href="mailto:msalferhobbs2013@my.fit.edu">msalferhobbs2013@my.fit.edu</a>
Brent Allard	<a href="mailto:ballard2013@my.fit.edu">ballard2013@my.fit.edu</a>
Adam Hill	<a href="mailto:ahill2013@my.fit.edu">ahill2013@my.fit.edu</a>
Christopher Kocsis	<a href="mailto:ckocsis2013@my.fsu.edu">ckocsis2013@my.fsu.edu</a>
Rohit Kumar	<a href="mailto:kumarr2013@my.fit.edu">kumarr2013@my.fit.edu</a>
William Nyffenegger	<a href="mailto:wnyffenegger2013@my.fit.edu">wnyffenegger2013@my.fit.edu</a>
Kartkea Sharma	<a href="mailto:ksharma2013@my.fit.edu">ksharma2013@my.fit.edu</a>

Submitted on 09/30/2016

Final Report (1)

**NORTHROP  
GRUMMAN**



# Table of Contents

<b>Table of Figures*</b> .....	<b>iv</b>
<b>Table of Tables*</b> .....	<b>iv</b>
<b>Abstract</b> .....	<b>vi</b>
<b>1. Introduction</b> .....	<b>1</b>
<b>2. Project Scope</b> .....	<b>2</b>
2.1 Goal Statement and Objectives .....	2
2.2 Constraints .....	2
<b>3. Work Break Down Structure</b> .....	<b>4</b>
3.1 Design .....	5
3.2 Communication.....	6
3.3 Navigation.....	7
3.4 Power .....	8
3.5 Perception .....	9
<b>4. Methodology</b> .....	<b>11</b>
<b>5. Conceptual Design</b> .....	<b>13</b>
<b>6. Design Specification</b> .....	<b>19</b>
<b>7. Performance Specification</b> .....	<b>20</b>
7.1 GPS .....	20
7.2 IMU.....	20
7.3 ZED Stereo Camera .....	20

7.4 Quadrature Encoders.....	22
<b>8. Conclusion.....</b>	<b>23</b>
<b>References.....</b>	<b>25</b>
<b>Appendix A.....</b>	<b>26</b>

## Table of Figures\*

Figure 1: Work Break Down structure for the Design team.....	5
Figure 2: Work Break down structure Communications.....	7
Figure 3: Work Break Down Structure Navigation.....	8
Figure 4: Work break down structure for the Power team.....	9
Figure 5: Work break Down structure for Perception.....	10
Figure 6: Prototype from last year's model.....	13
Figure 7: The autonomous vehicle from Lawrence Tech. University, The winner from 2016 IGVC.....	16
Figure 8: The initial 3D CAD model of Design Three.....	18
Figure 9: Piksi RTK GPS .....	20
Figure 10: NAV440 Inertial Measurement Unit .....	21
Figure 11: ZED 3D Stereo Camera.....	22
Figure 12: Quadrature Encoder .....	22

## Table of Tables\*

Table 1: Chart showing team and member task .....	4
Table 2: Work Break Down structure for the Design team. ....	12
Table 3: Work Break down structure Communications.....	15
Table 4: Decidsion Matrix.....	17

## Abstract

The Intelligent Ground Vehicle Competition is held yearly and requires teams to create an autonomous ground vehicle. This year the teams from FAMU-FSU College of Engineering (COE) and the Florida Institute of Technology (FIT) will work together to plan, code, and design an autonomous vehicle that will compete in this in this even. The COE team is mostly comprised of mechanical engineering students, while the FIT team is comprised of mostly computer science and computer engineering students. This report breaks down the design needs (both hardware and software components) in a hierarchal order of what aspects of the project are most important. Some of these aspects include cost, weight, accessibility, speed, safety, etc. Furthermore, it discusses the team layout and how the work will be divided. Since the two teams will be working together over a large distance it is important that different tasks are being addressed simultaneously in order to maximize efficiency. With that said teams are to be assigned, based on major aspects of the project, and the abilities of every team member. The major teams are as follows: Design, Robotics, and Programming. Lastly, this report discusses the competition layout as well as project requirements, needs and goals. The competition will be held on June 2, 2017 at Oakland University in Rochester, Michigan.

# 1. Introduction

Northrop Grumman and CISCOR Labs, have assigned Team 11 with the task of building an autonomous ground vehicle, for the Intelligent Ground Vehicle Competition (IGVC), hosted by Oakland University in Rochester, MI. An autonomous vehicle is a robot that is capable of localization, detecting paths, and maneuvering through terrain without any direct human interaction. In order to achieve this Team 11 has been assigned to work with a group of students from FIT to design, program, fabricate, and test an autonomous ground vehicle. For the most part, Team 11's contribution to this project is the design of the robot and the implementation of the low level technology. FIT's contribution, on the other hand, is due to the high level coding that is used in perception, object detection, and collision avoidance. The team is working diligently to have a working model by mid-December, and will be entering our final design to competition in June of 2017.

## 2. Project Scope

The overall project is to work in conjunction on a project with FIT using the process of distributed engineering. Both universities must collaborate on a project decided by the universities and meet weekly in order to delegate tasks and work efficiently from afar on the same project. The project chosen was the Intelligent Ground Vehicle Competition (IGVC). This competition requires these two teams to design, fabricate, and fully automate a vehicle that will complete a course determined by the competition.

### 2.1 Goal Statement and Objectives

The goal of this team is to implement distributed engineering to design and develop an autonomous ground vehicle capable of competing in the Intelligent Ground Vehicle Competition in June 2017.

Our ground vehicle must be able to autonomously perform the following:

- Object Detection
- Collision Avoidance
- GPS Navigation
- Line Following
- Color Detection
- Trajectory Mapping
- High Accuracy Localization

### 2.2 Constraints

IGVC has given the following constraints for the robot. The vehicle must:

- Not exceed a height of 6ft.
- Have a length between 3ft and 7ft.
- Have a width between 2ft and 4ft.
- Operate within the speed range of 1mph to 5mph.
- Have wireless and mechanical emergency stop buttons.



- The mechanical emergency stop button must be between 2-4 ft from the ground.
- Be able to carry a payload of 20 lbs. with dimensions of 18"x 8"x 8"
- Have a safety light that turns on then the vehicle is powered on, and flickers when the vehicle is in autonomous mode.
- Be able to detect and avoid obstacles.
- Be able to implement motion planning to reach a specified GPS waypoint with a 2 meter accuracy.
- Be able to follow lines.
- Be able to detect colors.

### 3. Work Break down Structure

Mentioned previously are the different competition goals associated with this project. On September 12, both schools met in order to discuss different task that needed to be accomplished. In order to reach the goals previously specified was crucial that teams be created to work on specific tasks, so they could be completed in a timely manner. See table below for a list of members associated with this project and which team they are currently placed in. Table 1. The team members and positions.

**Table 1: Sub Teams and Sub Team members**

FAMU-FSU College of Engineering			Florida Institute of Technology		
Members	Degree	Sub Team	Members	Degrees	Sub Team
<b>Andres Nodarse</b>	Mechanical Engineering	Design, Power, Communication	<b>Adam Hill</b>	Computer Science	Perception, Navigation, communication
<b>Ezekiel Copeland</b>	Industrial Engineering	Design, Power	<b>Brent Allard</b>	Computer Science	Perception, Navigation
<b>Justin Daniel</b>	Mechanical Engineering	Design, Navigation, Perception	<b>Christopher Kocsis</b>	Computer Engineer	Perception, Navigation
<b>Matthew Patton</b>	Mechanical Engineering	Design, Power	<b>Kartkea Sharma</b>	Computer Engineer	Perception, Power
<b>Tajaey Young</b>	Mechanical Engineering	Design, Navigation	<b>Matthew Salferhobbs</b>	Mechanical Engineer	Design
N/A	N/A	N/A	<b>Rohit Kumar</b>	Computer Engineer	Perception, Power
N/A	N/A	N/A	<b>William Nyffenegger</b>	Computer Science	Navigation, Communication

### 3.1 Design

As can be seen in Figure 1, members from the College of Engineering are mostly Mechanical Engineers. Therefore, all members have worked with Matthew Salferhobbs in brainstorming, concept generation, concept selection, and material selection. These students will also continue to be involved in any design changes that will be made. Most members serve to assist the design lead Matthew Patton while, Matthew and Ezekiel Copeland will work to create the necessary Cad models. Figure 1 below describes the Work break down structure for the design team. At the time this paper was being written Brainstorming, Concept Generation, Concept selection, and Material Selection have all been completed, while CAD modeling are in the refinement stage.

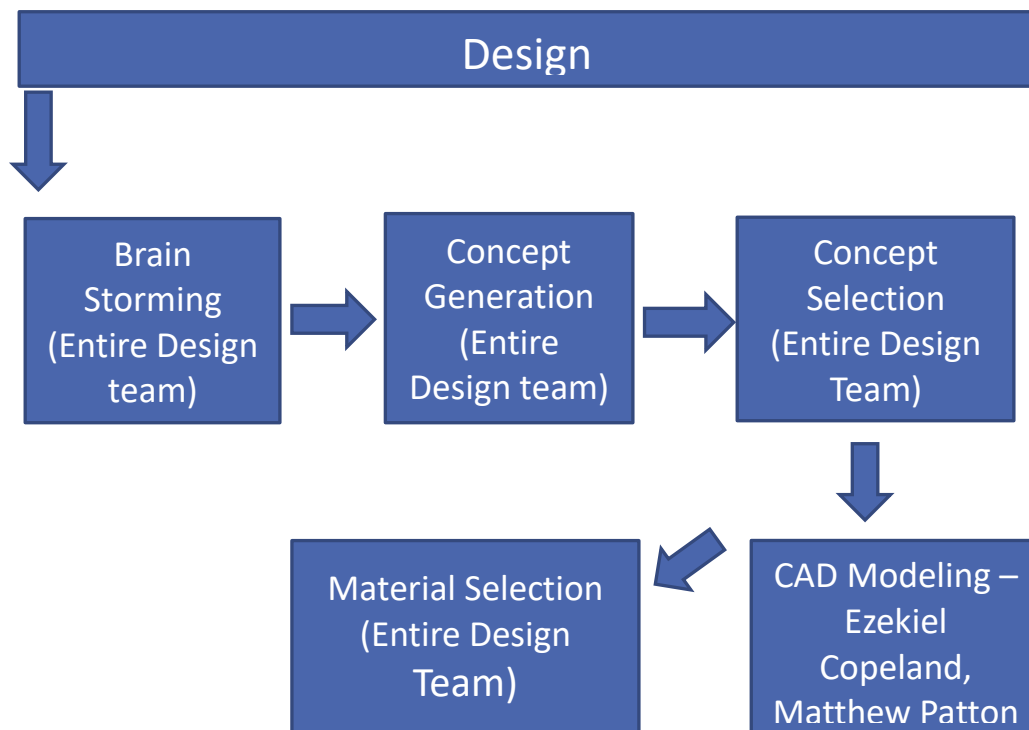

**Figure 1:** Work Break Down structure for the entire team.

## 3.2 Communication

In order to effectively compete in this competition our platform must be able to communicate between the many different sensors. These sensors are what will allow the autonomous vehicle to complete competition tasks such as objection detection, gps navigation, line following trajectory mapping and so on. This sub team is comprised of Andres Nodarse, Adam Hill, and William Nyffenegger. Essentially there are two main portions to this sub team, communication between low level hardware and communication between the necessary sensors. Andres Nodarse will be in charge of communication between low level hardware. Specifically working to transfer any data associated with the trajectory (data collected by the Li-Dar, ZED camera, and GPS) from TX1 to the controller running on the My-Rio. Through sub team's meetings, it was decided that Serial Peripheral Interface buss (SPI) would be implemented to accomplish this task. William Nyffenegger and Adam Hill will be in charge of implementing RabbitMQ, which is an Advanced Message Queuing Protocol. This protocol will create a server on the TX1 and this server will contain an exchange. Every sensor used in the design can then publish data to the sensor. This data will then be transferred to the controller using SPI as mentioned above. Once both communication protocols have been implemented, the entire team must get together to combine them. Please see Figure 2 below for this team's work breakdown structure.

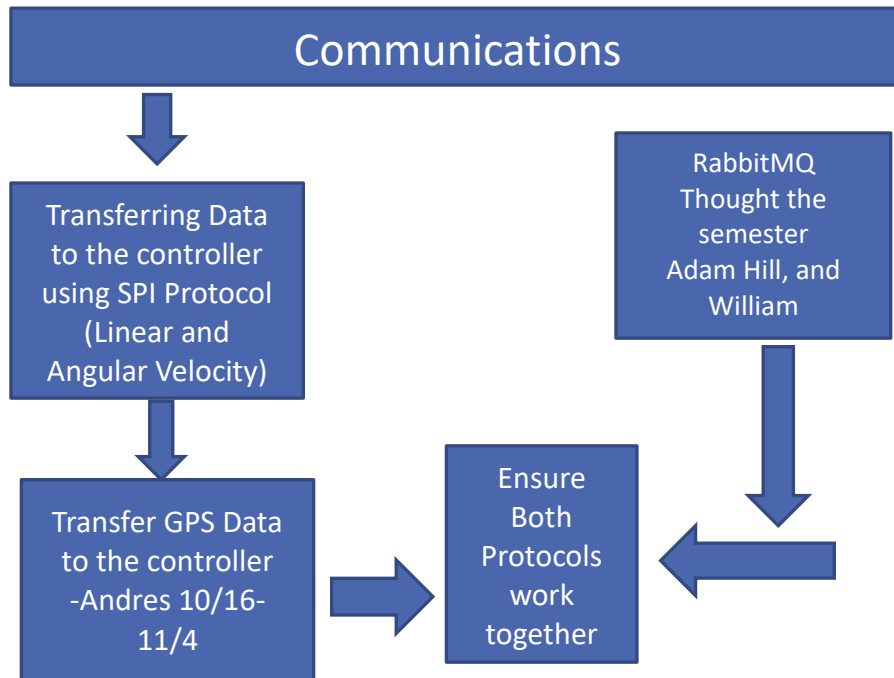

**Figure 2:** Work Break down structure Communications

### 3.3 Navigation

Per competition rules, the autonomous vehicle must be able to reach GPS waypoints, and maneuver around different obstacles on its way to those waypoints. Therefore, the platform must be able to localize itself with respect to the world. This will be done using the encoders, and the GPS swift kit. Justin Daniel will be in charge of localization for this sub team. Currently a Proportional Differential (PD) Controller takes data from the encoders. This controller will now have to implement the data collected from the GPS kit. Will Nyffenegger, Adam Hill, and Brent Allard, will be in- charge of creating different trajectories for the platform. These trajectories will be optimized using Sampling Based Model of Predictive Optimization algorithm (SBMPO and Property of Florida State University) to effectively plan out different paths around the obstacles. Please see Figure 3 to see the work Break down Structure for Navigation.

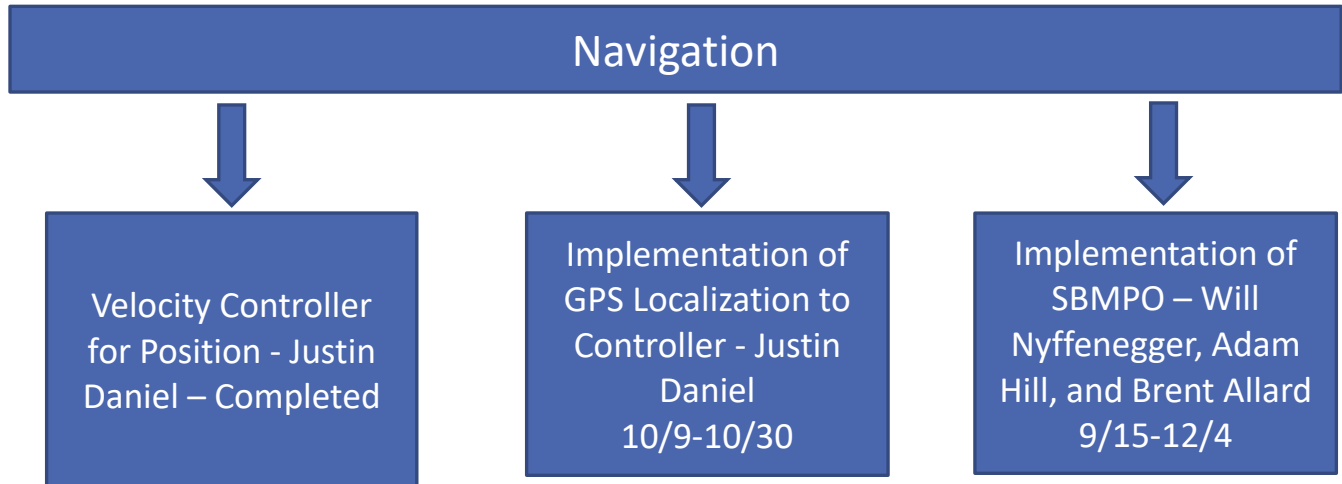

**Figure 3:** Work Break down Structure Navigation

### 3.4 Power

Sincere there is an abundant amount of hardware involved in this project it is important that the power is efficiently distributed. The power team's task will be to ensure that there will be a sufficient amount of power supplied to all the components of the platform. This team will include, Andres Nodarse, Ezekiel Copeland, Kartkea Sharma, and Rohit Kumar. Andres Nodarse and Ezekiel Copeland will be tasked with specking all the necessary hardware for the design. This includes sensors, motors, cameras, computers, and so on. Kartkea and Rohit will be in charge of creating the power diagram that will be used to organize the power distribution. Figure 4 shows the Work break down structure for the Power team.

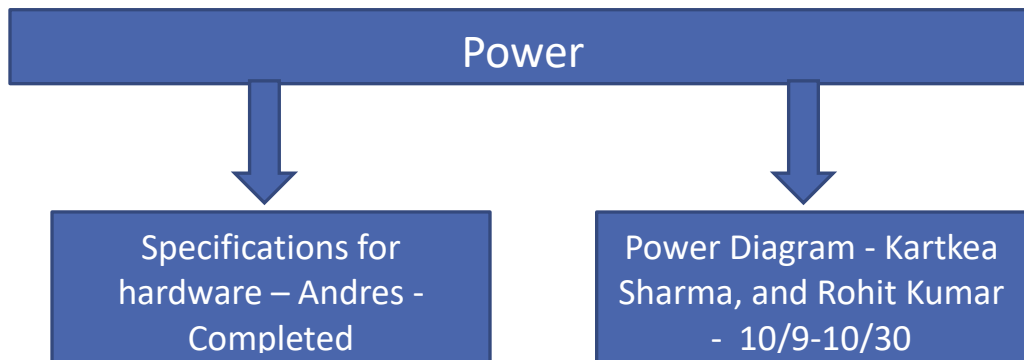

**Figure 4:** Work break down structure for the Power team

### 3.5 Perception

This team will be involved with handling all of the image processing of the robot. Recall from the previous sections that the platform must be able to implement line and object detection, as well as color detection. This team will be comprised of Adam Hill, Justin Daniel, Brent Allard, Christopher Kocsis, Kartkea Sharma, and Rohit Kumar. FIT's first step is to build an accurate simulation in order to test the perception software. They will accomplish this by using map-building algorithm that builds and updates course representation in real time. After the image processing is proven in a simulator, FIT will begin to work on image processing and obstacle detection in real time. This team will also be responsible for implementation of the Point cloud library and line/object detection using the zed camera. Please see Figure 5 for the work break down structure for the Perception team.

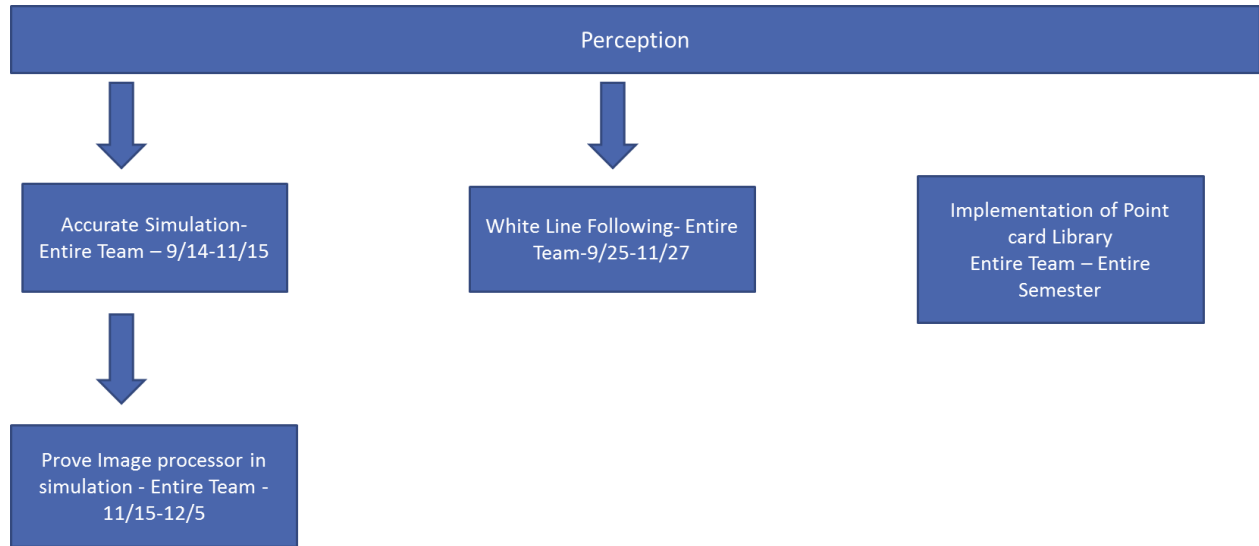

**Figure 5:** Work break down structure for perception

For a more detailed schedule please turn to Appendix to see the Gantt chart that was created for this design.



## 4. Methodology

It is important to address how the work will be split amongst the two entities. Since most of the members of the FIT team are Computer Science/Engineering students, they will be mostly handling the intelligence side of the project. This includes working with the hardware that will be used for image processing, and working with motion planning algorithms that will be required for the competition. The COE team will be more focused on design, as well as integrating much of the hardware, low level programming, and control.

The key to making this project work is constant and effective communication. The two teams meet once a week in full to discuss progression and future work. Weekly updates are required by our advisors to make sure we are sticking to our goals and deadlines. Subgroups have also been created to divide and conquer tasks, and they must also meet once a week to discuss task completion. The teams have also utilized file sharing websites such as GrabCAD and Google Drive to keep every member updated with the latest versions of reports and design files. A Gantt chart was created to view the task breakdown and set deadlines to make sure the project is being completed in a timely manner. The Gantt chart can be seen in Appendix A.

A House of Quality (HOQ) was created to compare the competition requirements to important engineering characteristics. The most important characteristics would ultimately be our primary focus for our design. This HOQ can be seen below in Table 2. At the bottom of the HOQ, the engineering qualities are ranked against each other; 1 being the most important, 10 being the least important. With that being said, it is clear that the weight of our vehicle is the most important in our design, with energy consumption being the least important. Weight has a very drastic effect on the size, durability, and speed of the robot. The characteristics highlighted in red indicate FIT's most important engineering characteristics, while the ones highlighted in blue are most important to COE.

**Table 2:** House of Quality

Row #	Weight / Importance	Engineering Characteristics	Column #											
			1	2	3	4	5	6	7	8	9	10	11	12
		Competition Requirements	Water Resistance	Structural Integrity	Affordability	Communication Protocols	Image Processing	Fabrication Time	Computation time	Energy Consumption	Power Distribution	Modular Design	Ventilation	Weight
1	4.0	Durability	2	10	6			5				5		7
2	5.0	Size of Robot		5	4			7		2				10
3	4.0	Localization	1			3			3		4	8	2	
4	5.0	Reliability	10	4	1	5	8						10	
5	2.0	IOP Challenge				10	8		6					
6	3.0	Speed			7		4		10					10
7	3.0	Accessibility		6	2			4				10		
8	5.0	Safety	5								7		4	
9	5.0	Motion Planning	1		5	3	10		3	2		6	2	
10	2.0	Innovative Design	4	3	4			2			2	4	1	6
		Score	92	109	109	117	118	71	106	20	51	92	88	120
		Rank	7.0	4.0	5.0	3.0	2.0	10.0	6.0	12.0	11.0	8.0	9.0	1.0

After analyzing the HOQ it is evident that FIT would focus mainly on the image processing, communication protocols, and Computation time; COE would focus mainly on the weight, structural integrity, and affordability of the vehicle. From here, the team was able to come up with different design aspects.

## 5. Conceptual Design

Team 11 inherited some hardware from the previous year's team along with a prototype to test on. This prototype is a crucial part to our project, this allows us to test different design specifications before making final decisions. This prototype assisted in our decisions to move forward with the design we did, this will be discussed below. The prototype acquired from last year was built of 2x4 pieces of wood. Being constructed of wood our team has been able to easily mount the hardware to the prototype for testing purposes. This prototype can be seen below in Figure 6, the frame is approximately 43in long, 18in tall, and 25 in wide.

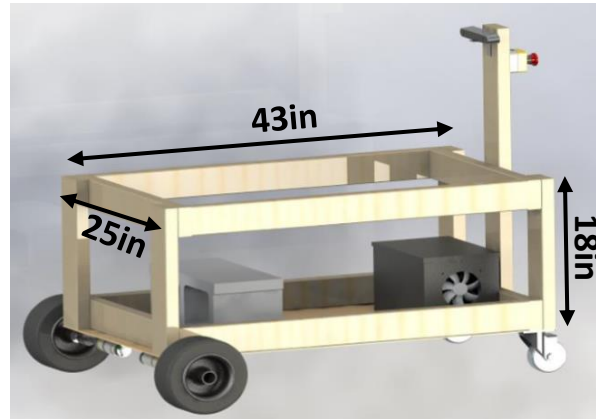

**Figure 6.** The prototype from last year.

It is important to mention the prototype does successfully locate the E-stop in between the height constraints for the E-Stop and now has a wireless E-stop built into the prototype. These E-stops are important for the safety of everyone and everything around the prototype when testing. After analyzing the research from last year's team and talking to several professions the team generated possible design options. Some of the information acquired from last year shows in the prototype the team constructed. This prototype has differential steering with two fixed wheels and two caster wheels. These caster wheels have three degrees of freedom, rotation around the wheels axis, rotation around the axis mounted to the frame, and translation along the ground. A topic discussed with our advisor, Dr. Nikhil Gupta, why did the previous team select differential

steering? Dr. Nikhil Gupta's dissertation is on Dynamic Modeling and Motion Planning for Robotic Skid-Steered Vehicles and knows an abundant amount of information of robotics. From talking with a professional on the subject our team has determined two forms of steering for the vehicle and the benefit and detriment to each form. Some of which include: skid steering has a higher energy consumption than differential but skid steering has more traction than differential. Also skid steering on a robot has a much harder controller written for the lower level tech than a differential steered robot although a skid steered robot would allow the robot to weigh more which from the house of quality weight is a major concern of the vehicle.

Upon talking to the Industrial Engineer on the team several different options to reduce weight while maintaining structural integrity of the body of the vehicle has been discussed. Some of these options include using fiber glass panels or carbon fiber panels. After talking to The High Performance Research Institute (HPMI) here in Tallahassee we have determined that it is possible to fabricate our own panels cutting down on cost from ordering these materials.

After our background research and talking to different professionals the team came up with a morphological chart, seen in Table 2, fulfilling the most important engineering characteristics. A morphological Chart helps generate several designs in order to determine different methods of accomplishing the problem at hand.

**Table 3:** The Morphological Chart

Requirements	Functional Parameter	Concepts or Solutions that satisfy the function			
Maneuverability	Forms of steering	Differential Steer	Skid Steer	Ackerman Steer	
	Support	Tracks	Wheels		
Structural	Frame	8020	Hollow square	Hollow round	Aluminum plates
	Fasteners	8020 Fasteners	Nuts and Bolts	Welding	
	Body	Carbon fiber	Fiber glass	Aluminum	Plastic
Positioning	Location of Hardware	Bottom center	Middle of robot		
	Location of Payload	On top	Over Front Wheels	Bottom center	
	Location of Motors	Inside	Outside		
	Location of Batteries	Bottom Sides	Middle of Robot		

The left side of Table 3 are directly correlated with how to accomplish the tasks at hand, the required components to the assembly. How the vehicle is going to maneuver, different steering methods and different possibilities of locomotion. How the vehicle is going to be structurally configured, framing options and the body's panels. Finally the location of the components of the vehicle: the payload, hardware, and batteries. As one can see from the Morphological Chart some of the functional parameters are highlighted, the areas highlighted are one of many designs but for simplicity only the final design is highlighted. Below is a decision matrix is created, labeled as Table 3, in this decision matrix three different designs were compared and rated against the winner from last year. The winner from last year was from Lawrence Tech. University their robot can be seen below in Figure 7.



**Figure 7:** Lawrence Tech. University, The winner from 2016 IGVC

This robot was purchased from Clear Path Robotics, one can see from the picture it is a skid steered robot with wheels. It is also waterproofed with an umbrella, which is one of the major concerns team 11 has with this design. Below in Table 4, once again for simplicity, only three designs are shown but in actuality several different designs were analyzed against the datum, the datum being the winner from last year.

**Table 4.** The Decision Matrix showing three designs.

Concept weighting [1=better than datum, -1=worse than datum]				
Engineering Char.	Datum	Design 1	Design 2	Design 3
Water Resistant	0	1	1	1
Structural Integrity	0	-1	-1	0
Affordability	0	1	1	1
Fabrication Time	0	-1	-1	-1
Energy Consumption	0	-1	0	1
Modular Design	0	1	1	-1
Weight	0	0	0	1
<b>Totals</b>	<b>0</b>	<b>0</b>	<b>1</b>	<b>2</b>

The three different designs analyzed in the table above were one: being a skid steered robot with tracks, the frame was made of 8020 T-slotted Aluminum tubing, this option is more expensive than hollow tubing but very modular, the design can later be changed a lot easier than if say the frame is welded together, and the aluminum plating as the panels. Design two: being a differential steered robot with wheels, switching to hollow aluminum tubes to reduce cost, and having a fiberglass body to reduce the weight from design two. Design three seen above in the morphological chart scored the highest score and therefore this design is the design team 11 is moving forward with. An initial design of design three has been constructed in PTC Creo Parametric and can be seen below in Figure 8.

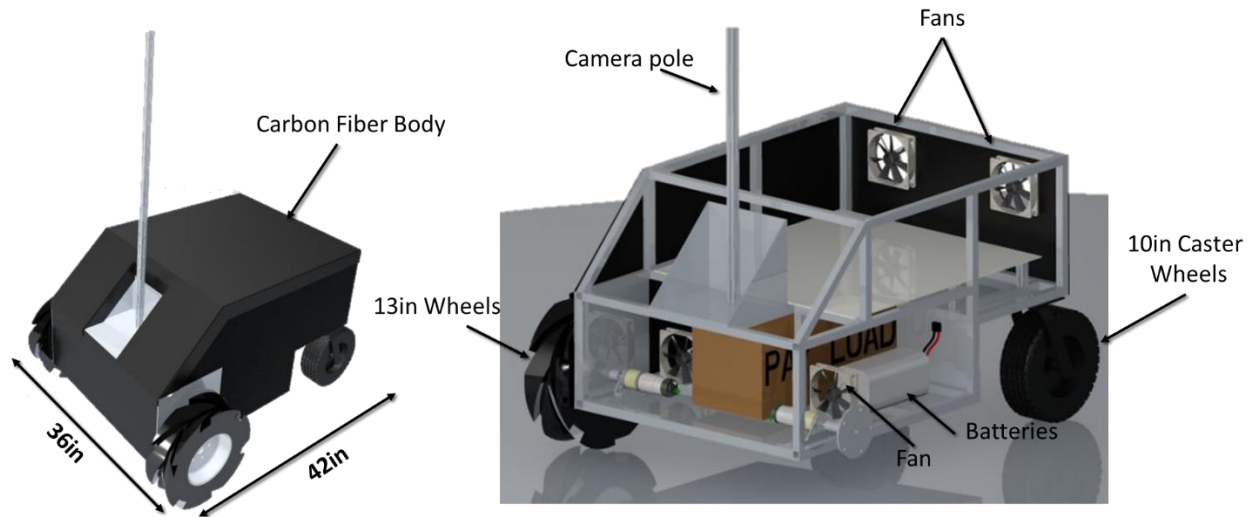

**Figure 8:** The initial 3D CAD model of Design Three.

In this design it is important to remember it consists of a carbon fiber body which will be manufactured by our Industrial Engineer with some resources from HPMI. The robot has differential steering with two fixed driven wheels and two caster wheels with three degrees of freedom. The payload is located low in the robot in a hidden compartment in order to keep the center of gravity low to the ground. Notice the camera pole will be sticking far above the vehicle causing a large moment which is important to account for when doing analysis on the robot possibly tipping over in bumpy terrain. Along with the payload the batteries are located low to the ground for the same reason mentioned before. The last thing to mention is the plate for hardware, the reason for this plate is to keep the electronics centrally located and easily accessible. Removing the lid lets the electronics to be looked at and inspected while also easily trouble shooting the functionality of the robot.



## 6. Design Specifications

After modeling the design shown above in Figure 9 there were several initial calculations done on the robot inside CAD. As mentioned above the most important engineering characteristic was found to be weight, then structural integrity, and then affordability. The weight is most important due to several factors, if the robot has a large pole with the camera mounted high up this creates a moment on the vehicle. The vehicle having to go over inclines and be able to operate in the grass with some holes it is important to do an analysis on the design in order to calculate where the center of gravity is and if it is low enough it may cause the robot to topple over. Also due to the weight of the vehicle the motors must be able to support the vehicle while moving in the speed constraints. Several calculations were made in order to determine if the motors purchased from last year will suffice for this design.

After analyzing the motors rated with a torque of 6.3ft\*lbs, and working backward the max weight the vehicle was calculated to be approximately 200lbs. This calculation was made with a few assumptions about the friction of the wheels on grass and the desired acceleration of the vehicle. To ensure the motors have enough torque a safety factor is being accounted for and team 11 would like to keep the weight under 100lbs. This theory was then tested by placing multiple cinderblocks on the prototype, weighing approximately a total of 130lbs including the weight of the vehicle. The prototype had no problem reaching the desired speed therefore the design will continue with the given motors.

## 7. Performance Specifications

### 7.1 GPS

The GPS we will use for the robotic platform is a Piksi Real Time Kinematic kit which will be used for navigation. This GPS can be seen below in Figure 9.



**Figure 9:** Piksi RTK GPS

The GPS has two separate streams of data that have different associated accuracies. The first stream is single point precision. Single point precision data will begin to broadcast from the GPS when it acquires a lock of at minimum four satellites. The accuracy of the single point precision is 2-3 meters which is typical of standard GPS. This accuracy is due to the distortion of the signal through the atmosphere. In order to increase the accuracy of the GPS a second GPS may be used as a base station. When this base station communicates with the moving GPS it will start broadcasting RTK fixed data. RTK fixed data measures the phase of the signals carrier wave and can achieve an accuracy of centimeters. For the Intelligent Ground Vehicle Competition the base station will not be used because it would violate the rules. This leaves the robot with a 2-3 meter accurate GPS that can be improved by additional sensors. However, centimeter accuracy will be very important for testing purposes and too fine tune other sensors.

## 7.2 IMU

The Inertial Measurement Unit that will be used for the robotic platform is a NAV440 series IMU from Xbow technologies that has been recently acquired by Memsic and can be seen below in Figure 11.



**Figure 10:** NAV440 Inertial Measurement Unit

The IMU has an accelerometer, gyroscope, and magnetometer giving the IMU 6 degrees of freedom. The IMU will provide full inertial data including angles, rates, and accelerations. The IMU has an accuracy of 0.2 degrees. The IMU has a high reliability with a mean time between failures of 25,000 hour. The IMU uses relatively low power, only consuming 4 watts. The IMU was designed for unmanned vehicle control, land vehicle guidance, avionics systems, and platform stabilization. The IMU will be used in conjunction with the GPS in order to increase the accuracy of the robotic platform to less than 2 meters.

## 7.3 ZED Stereo Camera

The ZED Stereo Camera is a 3D camera for depth sensing, motion tracking, object detection, and 3D mapping. The ZED Stereo Camera can be seen below in Figure 11.



**Figure 11:** ZED 3D Stereo Camera

The ZED will be used to perform the visual processing for the robotic platform. The ZED camera is designed to sense depth of 70cm to 20m working at 100 frames per second. The camera can also perform 6-axis positional tracking to get position and orientation. The camera is rated to perform with an accuracy of millimeters with a sampling rate of 100Hz. Using this 6-axis positional tracking objects can be detected as they come closer to the robot. This is the foundation for the autonomous operation of our robotic platform. The camera can also perform large-scale 3D reconstruction. The camera is rated for both indoors and outdoors.

## 7.4 Quadrature Encoders

The quadrature encoders came attached to the 2 stage planetary gearbox and a RS775 series motor. The quadrature encoders are used to determine the position of the robot due to the angular velocity of the wheels. An example of a Quadrature Encoder can be seen below in Figure 12.



**Figure 12:** Quadrature Encoder

These encoder values are directly used in the PD controller. The quadrature encoders have 7 pulses per revolution, or 28 pulses per revolution when the quadrature is taken into account. The operating voltage of the encoders are 5V DC, and can be powered directly through the MyRIO output rails. The encoders had four pins which correspond to power, ground, and encoder outputs A/B.

## 7.5 Raspberry PI 2.0

The raspberry is a small computer that will be used as an intermediary between the tx1 and the myRIO. The Raspberry PI can be seen below in Figure XX.



Figure XX Raspberry PI 2.0

The tx1 only has a limited amount of ports with which it can communicate with other devices. Most of these ports have been taken up by sensors such as the GPS, Zed, and LIDAR. Therefore, the Raspberry PI is a necessity in order to communicate with myRio. Essentially the tx1 one will send the desired trajectories to the Raspberry PI and relay that information to the myRio, which is running the motor controller. Another advantage to using the raspberry pi is its simplicity. It has been proven to be very simple to configure most general purpose inputs and outputs for certain needs of the project. For example, setting up the UART communication protocol, which will be discussed in more detail later in the report. See table XX below for the specifications for the Raspberry PI 2.0.

Table XX: Raspberry Pi Specs

Power:	5V, 2A
Ports/Connections	4 USB, 40 GPIO, Full HDMI port, Ethernet port, Micro SD card Slot
Hardware	900 MHZ quad- core ARM Cortex-A7, 1GB Ram

## 7.6 Buffalo Router High Power N300

This open source DD-WRT Wireless Router is a versatile wireless solution and can be seen below in Figure XX.



The router has two purposes. First, as a part of the interoperability guidelines the vehicle will need to communicate with the judges while it is maneuvering the course. With the long range capabilities of this router, the platform will be able to adhere to the iop guidelines. Once the distance from the course to the judge's tent is defined, the choice of router will be reassessed to

ensure it is capable of communicating at that range. Yet, it important to note that this router was recommended by researchers at Florida State Universities Ciscor lab as they have used it to communicate with their autonomous vehicles. This router will also be used to effectively implement a server that will be used to organize the communication within this platform. This server will be discussed in more detail later in the report. Please see table xx below for the specs of this router.

Table XX Buffalo AirStation HighPower N300

<b>Wireless Type</b>	802.11 a/b/g/n, 2.4 GHz Radio Frequency, 802.11 a/b/g/n
<b>Brand Name</b>	Buffalo
<b>Operating System</b>	Windows 7, Mac OS
<b>Item Weight</b>	7.2 ounces
<b>Product Dimensions</b>	2.2 x 8.7 x 9.4 inches





## 8. Conclusion

As mentioned in the report, FSU and FIT have been working together to design a robotic platform capable of trajectory planning and navigation. The ultimate goals of the project are to demonstrate cross-collaboration between universities, have a robot capable of autonomously navigating the above mentioned courses, and provide both teams robotic experience for future career paths. Specific sub teams have been created and meeting times have been decided on. These sub teams will handle the specific task mentioned in the Methodology section, and will aid in the modular design of the project. After background research on wheeled propulsion systems a decision was made to use a differentially driven platform over a skid steer platform. This decision was made on the fact that differentially driven vehicles have a much easier kinematic. This intern will make the controller for the platform easier to implement. Next an HOQ was developed that related competition constraints and engineering characteristics. This table showed that the most important aspects of the project are image processing, communication protocols, and affordability. Teams specific to these task have been formed in order to accomplish these tasks (along with others) simultaneously. Further work for this project will included fabrication of chassis, implementation of motion planning algorithms, and integration of subsystem to produce a final product.

## References

- [1] "The 25th Annual Intelligent Ground Vehicle Competition." *Homepage*. N.p., n.d. Web. 30 Sept. 2016. <<http://www.igvc.org/>>.
- [2] Dudek. "Differential Kinematics and Statics." *Advanced Textbooks in Control and Signal Processing Robotics* (2010): 105-60. *Computational Principles of Mobile Robotics*. Web. 05 Oct. 2016.
- [3] "Robo." *Robo*. N.p., n.d. Web. 30 Sept. 2016. <<http://groups.csail.mit.edu/drl/courses/cs54-2001s/skidsteer.html>>.
- [4] "Robo." *Robo*. N.p., n.d. Web. 30 Sept. 2016. <<http://groups.csail.mit.edu/drl/courses/cs54-2001s/diffdrive.html>>.
- [5] Gupta, Nikhil. *Dynamic Modeling and Motion Planning for Robotic Skid-Steered Vehicles*. Diss. Florida State U, 2014. Tallahassee: FSU Digital Library, 2014. *Diginole*. Web. 4 Sept. 2016.

# Appendix A

