

# The Development of the HANSCycle RLT Operation Manual



## Team 8 Members

Nicholas Khayata  
Darren Beckford  
Ali Pustelniac  
Michael Roddenberry

nak12@my.fsu.edu  
dbb11c@my.fsu.edu  
agp12@my.fsu.edu  
mkr14b@my.fsu.edu

## Faculty Advisor

Keith Larson

## Sponsor

Gordon Hansen

## Instructors

Dr. Chiang Shih

## Table of Contents

<b>Table of Figures.....</b>	<b>i</b>
<b>Table of Tables .....</b>	<b>i</b>
<b>Acknowledgements .....</b>	<b>ii</b>
<b>Abstract.....</b>	<b>iii</b>
<b>1. Introduction.....</b>	<b>1</b>
<b>2. Problem Statement.....</b>	<b>1</b>
<b>3. Project Scope .....</b>	<b>1</b>
<b>4 How It Works .....</b>	<b>1</b>
<b>4.1 RLT .....</b>	<b>2</b>
<b>4.2 Brakes.....</b>	<b>2</b>
<b>4.3 S&amp;S Coupling .....</b>	<b>2</b>
<b>4.4 How To Use It.....</b>	<b>2</b>
<b>5. Risks .....</b>	<b>4</b>
<b>6. Price/Cost.....</b>	<b>4</b>
<b>7. Functional Analysis.....</b>	<b>6</b>
<b>8. OEM Parts.....</b>	<b>8</b>
<b>9. References.....</b>	<b>9</b>
<b>10. Appendix.....</b>	<b>A</b>

**Table of Figures**

**Figure 1: HANSCycle initial drawing.....4**  
**Figure 2: RLT Internals .....6**  
**Figure 3: RLT Exploded View..... 7**

**Table of Tables**

**Table 1: Procurement Analysis..... 4**

## **Acknowledgments**

Team 8 would like to thank the FAMU-FSU College of Engineering for providing the opportunity to further our knowledge in the pursuit of academic excellence in not only this project, but all of our coursework. Special thanks is also given to Dr. Chiang Shih and Mr. Keith Larson for their contributions and insight into this project. Our sponsor, Gordon Hansen, has been a very helpful and involved aid in the design of the RLT prototype bicycle, and all adjustments throughout this year. The team's research and project has also been assisted by various professors at the College of Engineering, along with the school's Machine Shop.

## **Abstract**

Team 8 was tasked with the testing and optimization of the current HANSCycle prototype. This prototype utilizes the reciprocating lever transmission invented and patented by our project sponsor Gordon Hanson. The HANSCycle's main purpose is to be a viable alternative to current commuter style bicycles that have several drawbacks including lack of torque and the potential for knee damage. Due to the 360 degree revolution, the crank arms on a traditional bicycle are limited due to ground clearance. The 100 degree arc length of the RLT allows for longer crank arms, thus producing more torque available for strenuous rides up steep grades. The other benefit the the RLT design is that you avoid the two "dead" spots present in a traditional bicycle. These "dead" spots are located at the top and bottom of the pedal motion were no useful work can be produced and causes unnecessary stress on the rider's knees, which is believed to cause joint issues over time.

## **1. Introduction**

Sponsor Gordon Hansen patented a reciprocating lever transmission (RLT) transmission with the goal of using the RLT to enhance the traditional bicycle by creating the HANSCycle. The HANSCycle is a bicycle that is constructed with the Patented RLT. The main difference between a traditional bicycle and the HANSCycle is the pedal motion. A traditional bicycle uses a 360° rotational crank motion whereas the HANSCycle uses a reciprocating motion with arc no greater than 100°. The 360° on the traditional bicycle has two dead spots at the top and bottom of the pedal motion which no torque nor power. In addition to those dead spots, the crank motion on the traditional bicycle causing pain and stress on the knee joints of riders especially when riding uphill. The RLT is designed to combat these issues by easing stress on the knee joints while also consistently providing more power and torque. As a result, riding uphill will be easier for the common rider.

## **2. Problem Statement**

“A traditional bicycle is difficult to ride up hill due to its limited torque output and can also be damaging to a rider’s joints.”

Team 8 has been tasked with developing a working HANSCycle implementing the Reciprocating Lever Transmission (RLT). The goal of this design is to improve upon a few aspects of the traditional bicycle, including two ‘dead spots’ at the top and bottom of a normal pedal rotation, as well as alleviating joint damage to the user from these dead spots. If successful, the HANSCycle will be more power efficient and ergonomically comfortable for the user. Once a working prototype has been developed, the team must test it and compare values such as torque, cadence, work, and speed, with values of a Traditional Bicycle. This project hopes to prove that a reciprocating lever transmission on bicycle can obtain similar results in performance compared to a traditional bicycle, while also causing less stress and damage to the rider’s joints.

## **3. Project Scope**

Gordon Hansen, the HANSCycle sponsor, believes his redesign of the traditional bicycle will lead to a new age of bicycling. The goal of the Reciprocating Lever Transmission is to maximize efficiency and ease stress on the user’s joints due to the “dead spots” in a traditional bikes transmission. These “dead spots” can cause joint harm and are uncondusive to an efficient ascent uphill. He believes that the short crank arms on traditional bikes require more work from the bicycle rider, and has therefore patented his design. The RLT incorporates larger crank arms that can produce more torque and travel in an arc no greater than 100 degrees, which avoids the dead spots.

## **4. How it works**

### **4.1 RLT**

The Reciprocating Lever Transmission, or RLT, works by using a ratchet and pawl system to engage the output shaft in one direction, while allowing the teeth to slip in another. This is done by the use of two main 45 tooth bevel gears that are situated to the outer edge of the RLT. The bevel gears are driven by pressing down on the pedal which applied torque to the output shaft. This large bevel gear is in mesh with five bevel gears that are mounted within the RLT which in turn is in mesh with another bevel gear on the other side. This allows for dependent motion,

meaning as one crank arm moves down, the other crank arm must move up. This is repeated after a 90 to 100 degree cycle. Mounted to the center axle or output shaft are the two ratchet and pawl mechanisms. These systems are mounted in opposite directions so that while one is engaged, the other is allowed to freely slip. That means as the crank arm moves the output shaft is always powered in the forward direction to produce usable power.

## **4.2 Brakes**

The HANSCycle uses off the shelf hydraulic brakes which are composed of several components. The brake discs are dependently attached to the front and rear wheels of the HANSCycle. This means that if the angular velocity of the disc decreases so does the wheels which in turn slows down the HANSCycle. They are slowed by means of friction from the brake pads which are pressed onto the disc due to the master cylinder driving a non-compressible brake fluid within the sealed brake lines to the pads. The user creates this pressure simply by pulling on the brake levers on both the left and right handlebars. Applying the left brake lever will engage the front brakes, the right will engage the rear brakes, while squeezing both levers will apply force to the front and rear brakes.

## **4.3 S&S Couplings**

S&S Machine Bicycle Torque Couplings are used within the bicycle frame in order for the frame to be taken apart to fit into travel cases or for storage. They are designed using a high quality stainless steel and lock together using two primary systems. Internally the coupling has a system of lugs that lock in together and the external coupling housing incorporates a threaded screw on system that further locks it together and seals the unit together.

## **4.4 How To Use It**

The RLT HANSCycle is used in a very similar way the traditional bike is used. The main difference between the RLT HANSCycle would be the pedal motion. Instead of a 360° rotational motion, the HANSCycle works on a 90° to 100° reciprocating motion. As the rider pedals downward on one crank arm, the other crank arm is driven upward.

To use it the rider will wear the proper safety equipment existing of helmet, knee and elbow pads and any other necessary equipment. Once the rider in the seated position the rider is ready to begin powering the HANSCycle.

To power the HANSCycle the rider will pedal the crank arms in a reciprocating motion. As one crank arm moves downward the other one will move upwards. The cycle will begin moving forward just as a traditional bicycle would. Once the first pedal gets the bottom position, apply a downward force to the other pedal so that it goes down and the bottom pedal is driven upward. This process will be repeated at the desired cadence to increase or decrease speed.

The handle bars are used to steer the HANSCycle just like a traditional bicycle. This can be accomplished by simply pushing on one side of the handle bars with one hand, while the other hand pulls towards the body.

There are also hydraulic brakes on the handlebars that are available to slow or bring the HANSCycle to a complete stop. The brake lever located on the left handle is used to engage the front brake, while the right brake lever can be used to engage the rear brake. Both can be used at the same time to maximize the braking power, and it should be noted that engaging the front brake alone could cause the HANSCycle to lose control do to the front wheel locking up at high speeds.

The HANSCycle does not roll backwards so additional steps must be taken to suddenly change directions. First the rider may attempt to make a sharp turn by pushing on one side of the handle bars, while pulling on the opposite side. To move backwards the rider must lift the cycle and place it in the designated direction or lift the rear tire off the ground while moving it backwards.

The S&S couplings can be used to take apart the HANSCycle frame for easy storage or travel. To take the couplings apart the S&S coupler tool can be used to unscrew the threaded portion of the coupling and then can be further disassembled by using your hands.

The HANSCycle is also equipped with a Shimano 11 speed internal gear rear hub. To change gears on the HANSCycle is just like on a normal multi speed bicycle. Simply use the gear shifter located on the right side of the handlebar to shift through gears 1-11. This allows for easy use based on the demand of the rider and terrain at any moment. Lower gears will allow for easier pedaling in high demand situations such as riding up steep grades, while the higher gears will allow for faster top speeds in low torque applications.

One desired feature was the ability to easily break down and store the HANSCycle for travel. To minimize the size of the HANSCycle, a few steps is required. First deflate the front and rear tires. This will decrease the footprint of them about 1.5 inches each. Next the crank arms can be removed and reinstalled backwards. This will keep them in place, but they will store neatly within the rear triangle of the frame. The S&S couplings can then be disconnected in the two frame locations. This will allow for the front and rear half of the HANSCycle to be separated or stacked to minimize storage space. Lastly, the front wheel can be easily removed to further breakdown the HANSCycle and minimize storage space.

Figure 1 below further illustrates how the HANSCycle is used.

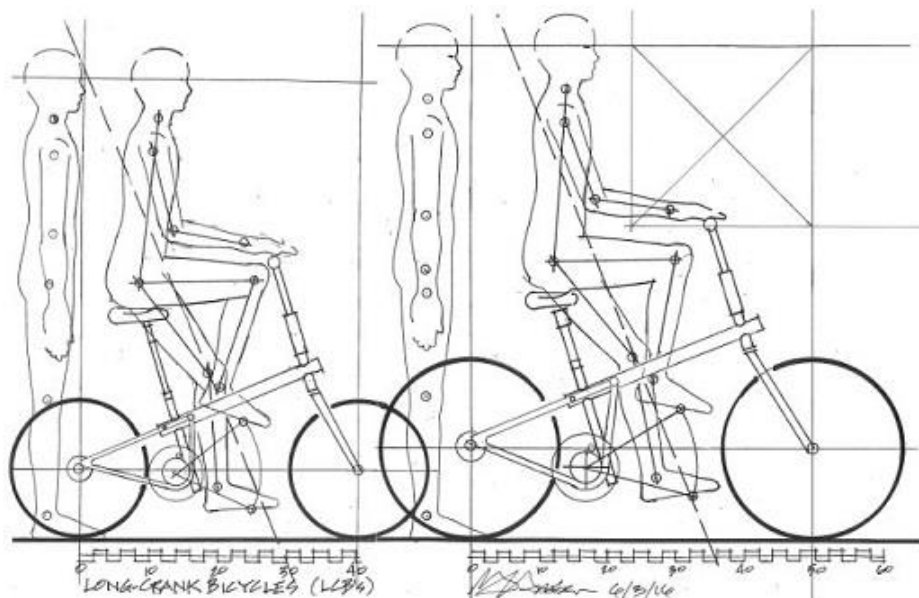



Figure 1: HANSCycle Initial Drawing

### 5. Risks

Riding a bicycle always has some risks associated with it. Even Though the HANSCycle is constructed of strong and reliable materials, there is still possibility of the HANSCycle malfunctioning. There will be noise when riding the bike due to the grinding of the ratchet and pawl system. Some of the risks include: shaft shearing, bolts shearing, the gears on the bike can jam causing trouble pedaling. Also, the seat positioning of the HANSCycle. To fix these issues, one must take apart the RLT to service each individual component.

### 6. Price/Cost

Many of the components of the HANSCycle failed. Therefore, many of the components needed to be replaced. New metal for the crank arms, new bolts and metal for the shaft has been on the list of items for purchase. Originally Team 8 had a budget of \$2,000 to spend on anything that would be an asset to building a working prototype. Below is the list of materials that has been purchased by team 8 this year. (note: shipping and handling prices are not listed)

Table 1: Cost/Budget Breakdown

#	Part	Vendor	Cost	Quantity	Subtotal
1	Needle Bearing	McMaster.com	\$16.65	3	\$49.95
2	Rotary Shaft	McMaster.com	\$8.20	2	\$16.40
3	Socket Head Screws	McMaster.com	\$9.05	1	\$9.05
4	Locknuts	McMaster.com	\$9.03	1	\$9.03
5	½ in. Hexagon Broach	McMaster.com	\$241.89	1	\$241.89
6	M12-1.75 Class 10 flange locknut	McMaster.com	\$10.65	1	\$10.65
7	⅞ in. diameter 3 ft. 8620 alloy steel rod	McMaster.com	\$22.68	1	\$22.68
8	14mm ID 18mm OD Oil-embedded sleeve bearing	McMaster.com	\$1.75	4	\$7.00

9	14mm ID 16mm OD Dry-running sleeve bearing with steel shell	McMaster.com	\$4.23	2	\$8.46
10	Oneway Bearing with Keyway	VXB bearings.com	\$24.95	5	\$49.90
11	rachet and pawl	Triton cycles (UK)	\$90.00	2	\$180.00
12	square tube	speedy metals	\$5.95	1	\$5.95
13	round bar (shaft)	speedy metals	\$6.89	1	\$6.89
14	steel plate	speedy metals	\$29.53	1	\$29.53
15	square bar	speedy metals	\$21.16	1	\$21.16
16	socket screws	Mcmaster.com	\$9.82	1	\$9.82
17	SUB1.5-4515 45-tooth bevel gear	KHKgears.com	\$84.63	2	\$181.14
18	KSUB1.5-1545	KHKgears.com	\$34.42	1	\$34.42
Total					\$1105.34
Remaining Budget					\$894.66

## 7. Functional Analysis

The Prototype can be broken down into a few major components: The RLT, the frame, and OEM (Original Equipment Manufacturer) Parts.

The RLT

The RLT, or Reciprocating Lever Transmission, can be seen below in Figure 2.

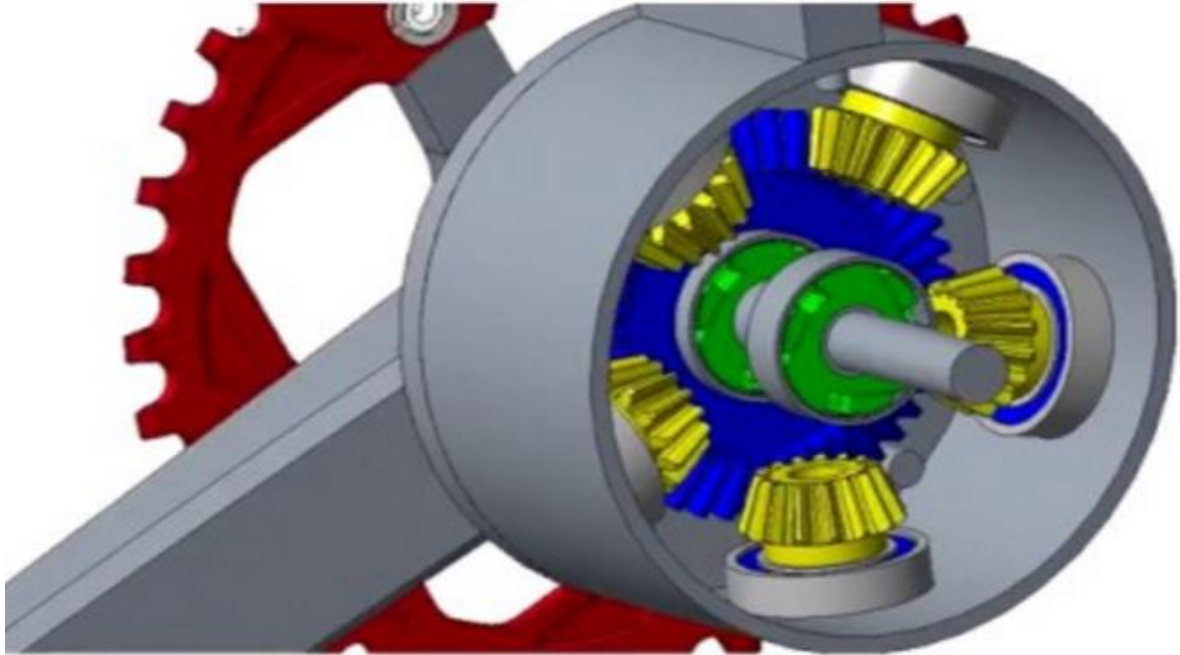

Figure 2: Internal view of RLT

The RLT consists of bevel gears, (in background of picture in blue), 2 ratchet and pawls (in green), an inner shaft, (middle grey cylinder), and pinions. Crank arms are attached at either end of the inner shaft. As the rider pushes a crank arm downward, the ratchet and pawl on the corresponding side engage and rotate the inner shaft, while the ratchet and pawl on the other side move freely. The bevel gear pinions (around inner diameter, in yellow), spin the opposite crank arm and bevel gear (not pictured) up, at the same rate that the other crank is being pushed down. The process is then repeated when the opposite crank arm is pushed downward, and continues throughout the bicycle's use.

The bevel gears used in the RLT are made of SUS303 stainless steel. There are also multiple bearings used in the mechanism. The five bevel gear pinions are held in place in the bevel housing using roller bearings. The two large bevel gears are held in the bevel gear seal plates by roller bearings as well there are bearings in each of the crank arms, where they attach to the large bevel gears. The bearings assist in reducing friction between the various moving parts, as well as preventing wear.

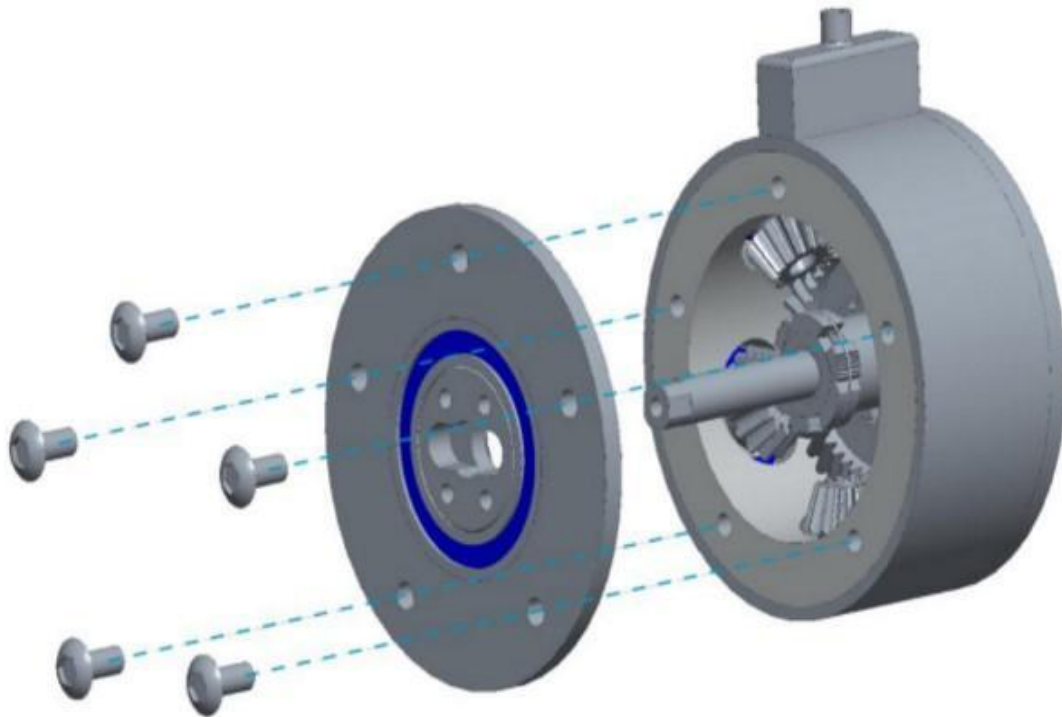

Figure 3: An exploded view of the RLT

Two ratchet and pawl systems are used in the bicycle prototype and are attached to the inner shaft. These were installed in opposite directions, to enforce the upwards/downwards motion of the crank arm. As one crank arm is pushed down, the corresponding ratchet and pawl engage, rotating the shaft and moving the bicycle forward. During this time, the opposite ratchet moves freely, allowing the bevel gear pinions to move in the corresponding direction as well. As the other crank arm is pushed, the process switches, and repeats as each crank arm is pedalled.

The chain ring is attached to the chain ring adapter, which is attached to the axle. The chain wraps around the chain ring, which is connected to the rear wheel of the bicycle, which is driven forward when the crank arms pedal and move the RLT mechanism.

The bicycle also consists of two crank arms, on either side, as pedals. These are attached to the two large bevel gears inside the RLT. These crank arms were manufactured using 1018 and 4130 Steel, and have been refabricated to provide optimum alignment and strength. The pedals attach to the end of each crank arm.

#### Frame Components

The bicycle frame was manufactured out of chromoly tubing, due to its light weight, low cost, and high strength. The S&S couplings and bottom bracket are two main features of the frame. The entire frame weighs only six pounds.

The S&S couplings allow the rider to disassemble the frame for shipping purposes. As requested by the sponsor, the HANSCycle is to be able to be disassembled and shipped in a 26x26x10 inch shipping container. The couplings can be separated by hand. The bracket on the bottom of the frame is intended to accommodate a standard bicycle crank, if desired. This would require the

rider to remove the RLT and connect the standard crank to the rear hub, which would change the function of the bicycle.

## **8. OEM Parts**

There are three main OEM components used in the HANSCycle prototype. These include the disc brakes, the internally geared hub, and the clipped pedals. Below is a brief description of each:

1. The hydraulic disc brakes allow the rider to quickly stop the bicycle, even at high speeds. When the brake lever is squeezed, the piston inside the master cylinder is actuated, moving the fluid towards the brake caliper, causing pressure in the brake system. This pressure pushes the pistons towards the rotating wheel, slowing down the bicycle by use of friction.
2. The 11 speed Shimano hub allows the rider to use the gear shifter on the right handlebar to change speeds. This allows the rider to find a comfortable level of resistance, depending on the setting and conditions of the bicycle ride. The internally geared Shimano hub is attached to the rear wheel and chain, which allows the rider to switch gears for maximum performance.
3. Clipped pedals allow the rider to attach compatible footwear, in order to generate power on the upstroke as well as the down stroke. The pedals are attached to the crank arms, but compatible footwear must be purchased separately.

## 9. References

1. "CSK10PP One Way Bearing with Keyway Sprag Freewheel Backstop Clutch." *VXB.com Bearings*. Web. 21 Nov. 2016. <<http://www.vxb.com/CSK10PP-One-way-p/kit18270.htm>>.
2. "Halo DJD Supa Drive Driver." *Halo DJD Supa Drive Driver / Triton Cycles*. Web. 20 Nov. 2016. <<http://www.tritoncycles.co.uk/components-c9/hub-spares-skewers-c122/halo-djd-supadrive-driver-p13565>>.
3. Hansen, Gordon Harold. Reciprocating Lever Transmission. Gordon Hansen, assignee. Patent US20130205928 A1. 15 Aug. 2013. Print.
4. Holland, Connor. *Needs Assessment: Team 20: HANS Cycles*. Rep. 2015. Print. "RESOURCES." *Speedy Metals - Steel Square Tube*. Web. 18 Nov. 2016. <<http://www.speedymetals.com/c-8251-square-tube.aspx>>.

# 10. Appendix

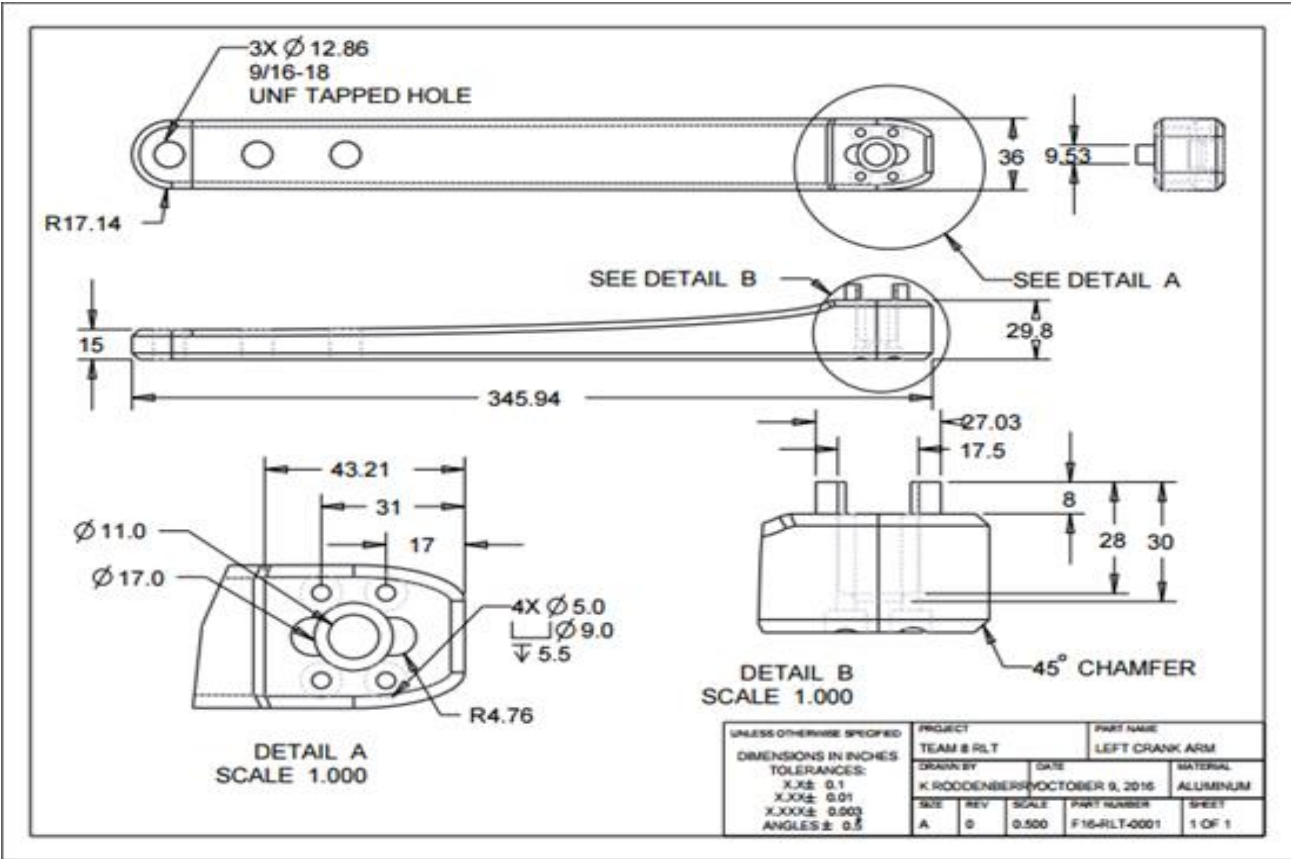

Figure 8. Detailed drawing of the revised crank arms.

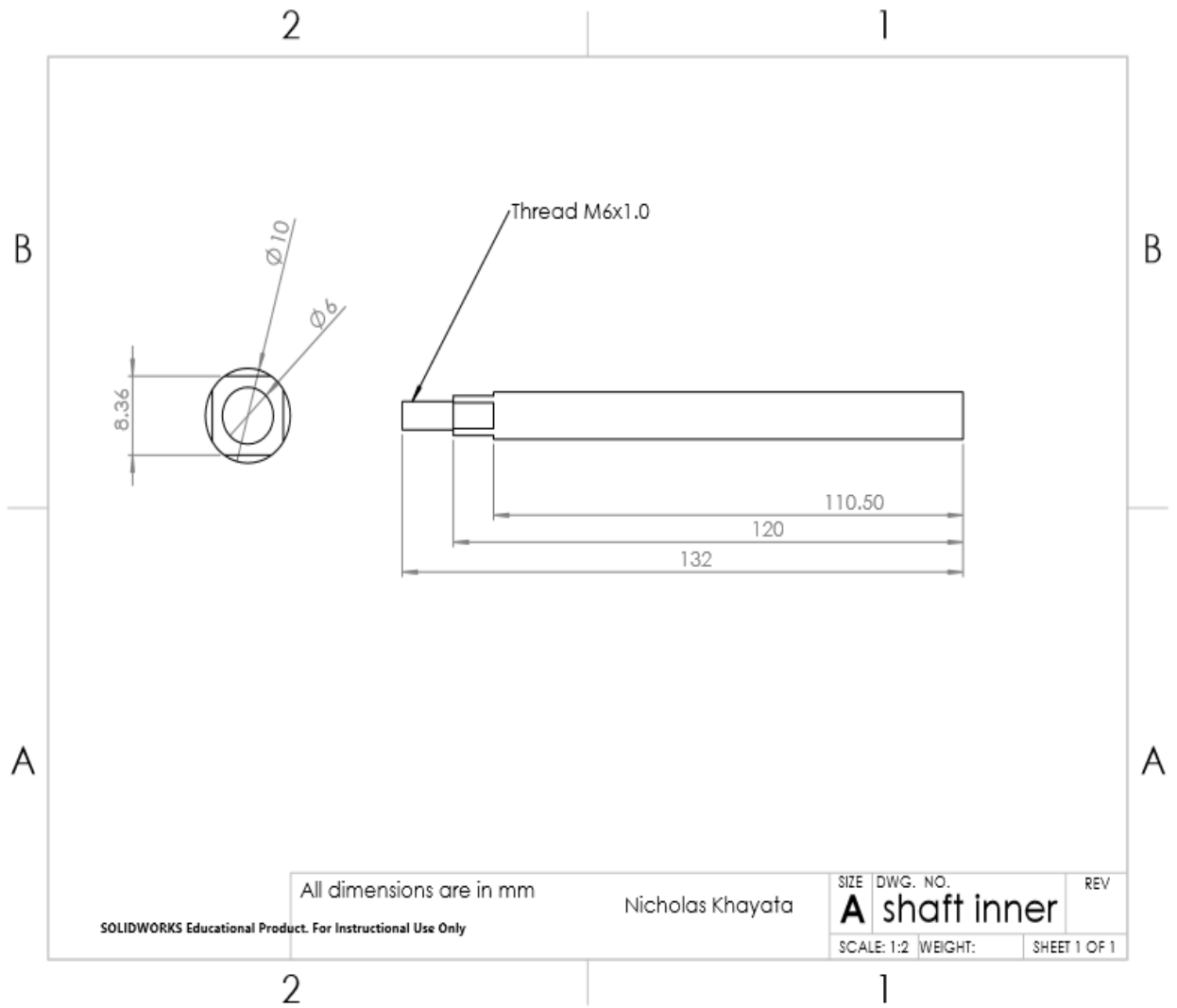

Figure 9: Drawing of inner shaft



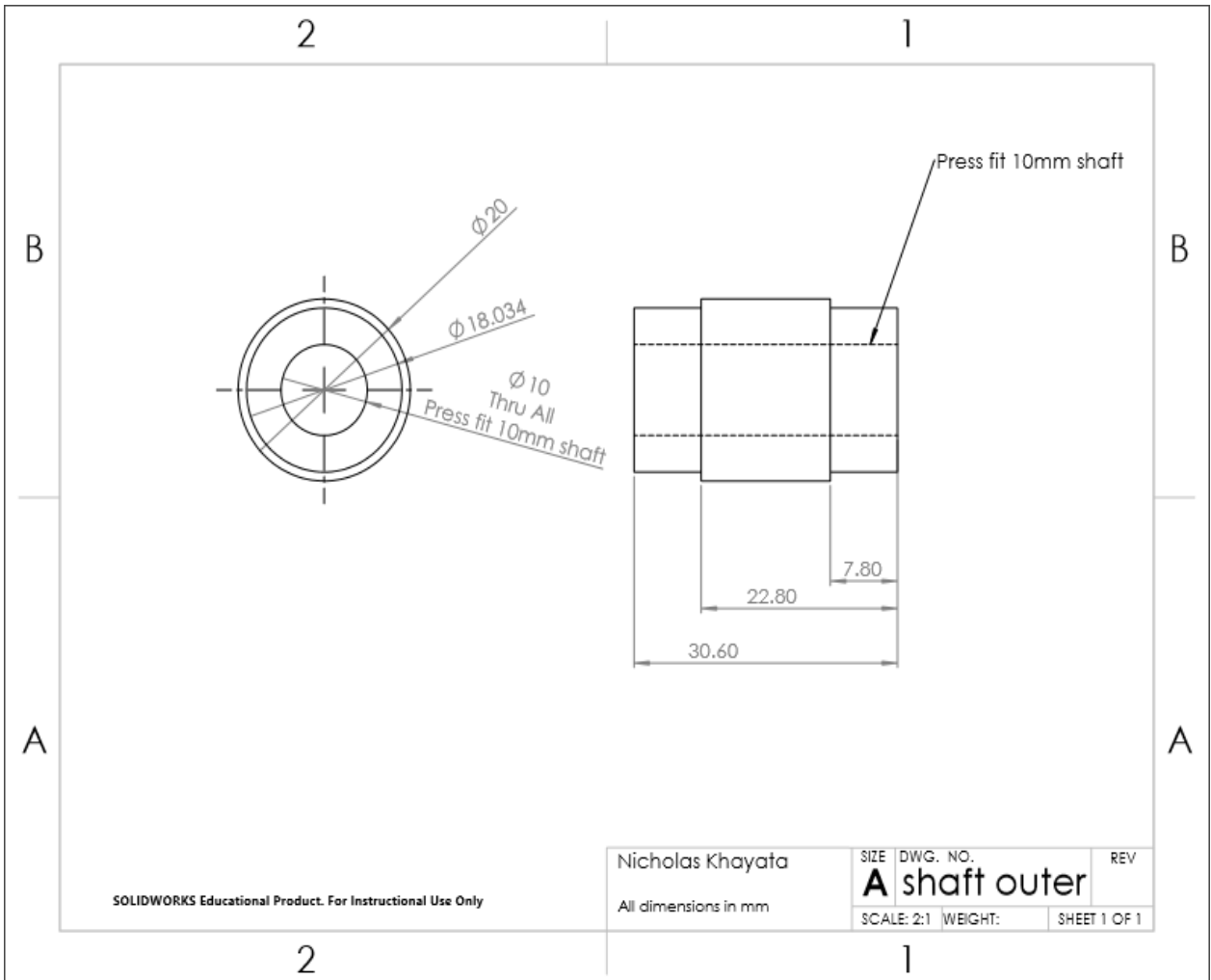

Figure 10: Drawing of outer shaft

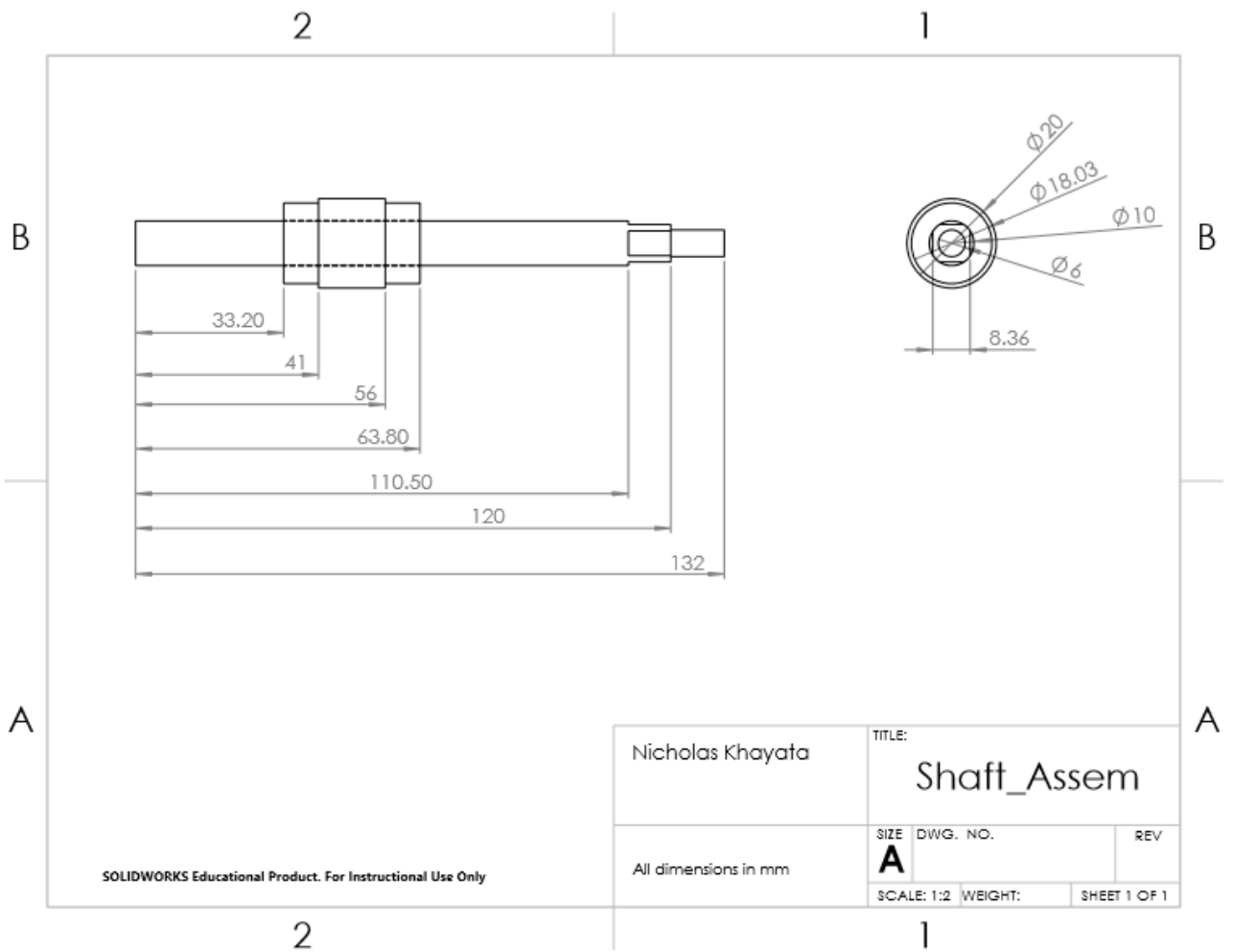

Figure 11: Drawing of shaft assembly

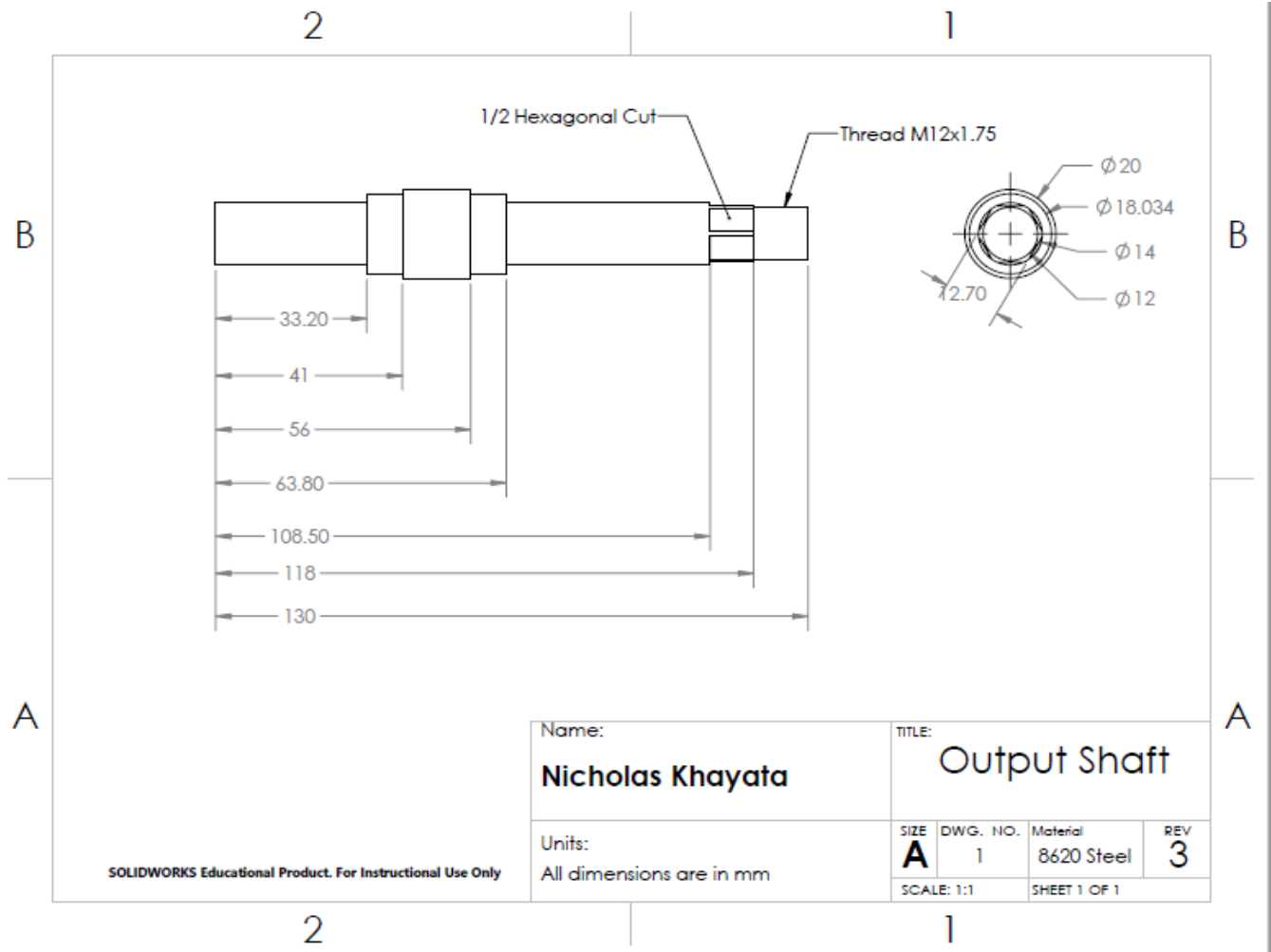

Figure 12: Output shaft drawing