



Proton Therapy Device Manager

.decimal

Spring Midterm 2 Presentation

Instructors: Dr. Shih & Dr. Gupta

Advisor: Dr. Clark

Team 14

Micah Baxter

Morgan O'Rorke

Sarah Sweat

Outline

- Background
- Project Motive
- Needs Statement
- Project Scope
- Design Concept
- Electrical Design
- Gantt Chart and Budget
- Summary
- Questions



.decimal

- Manufacturer of radiation therapy products
- Based in Sanford, Florida
- Established in 1986
- Helped over 50,000 patients



Proton Therapy

- Newest form of radiation treatment
 - Protons instead of x-rays
- Technician manually loads apertures
- Walk through reinforced hallways between dosages.
- Process takes about 4 minutes per aperture



Project Motive

- Reduce patient treatment time
- Reduce physical effort of technician
- Increase patients treated per day
- Improve the patient's proton therapy experience

Needs Statement

Develop an automated device that safely loads and unloads apertures from the nozzle of the Mevion S250 proton therapy system.

Project Scope

Provide proof of concept by designing and building a 1:4 scale model of our automated system.

Apertures

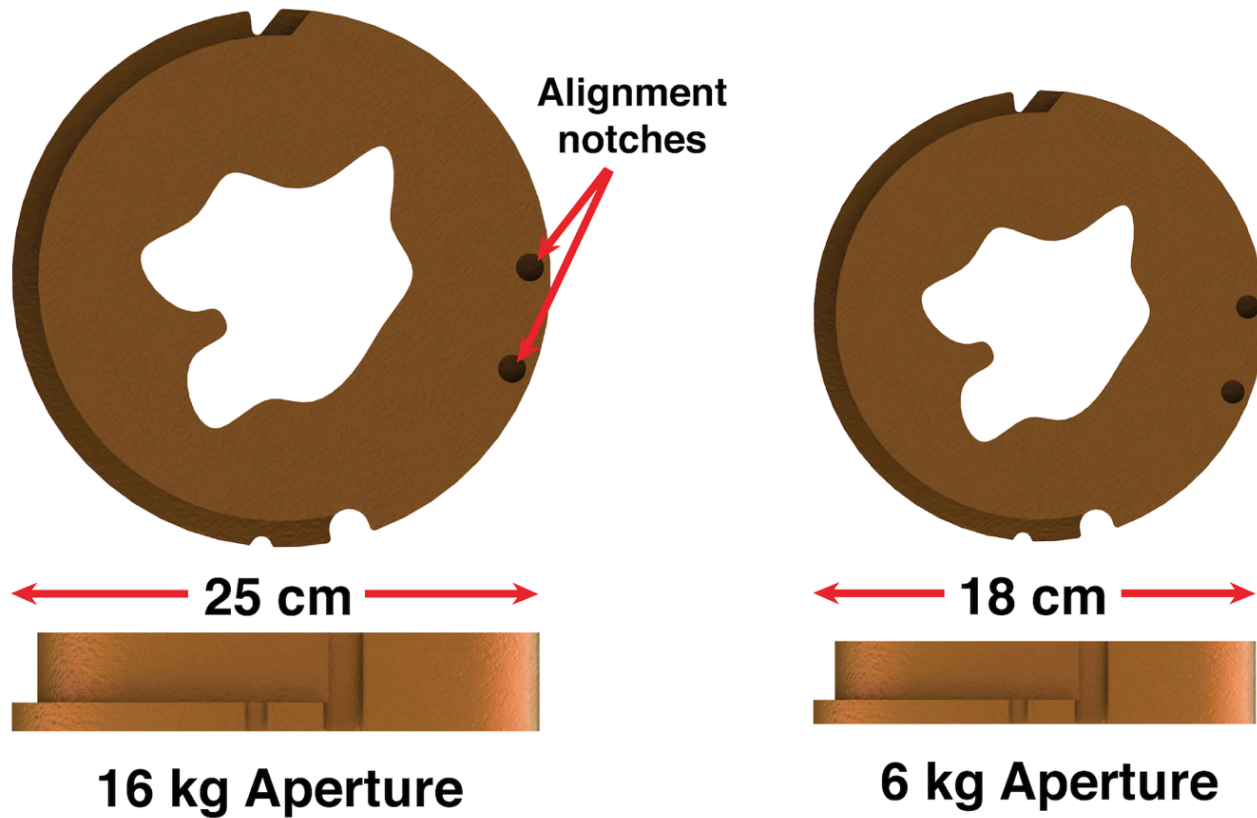

Design Concept

Nozzle



Design Concept

- Linear rail system
- 8 mm pitch rod
- Nema 17 steppers
- Accuracy: 40 microns
- 4.5:1 gear ratio
- 1 minute loading time

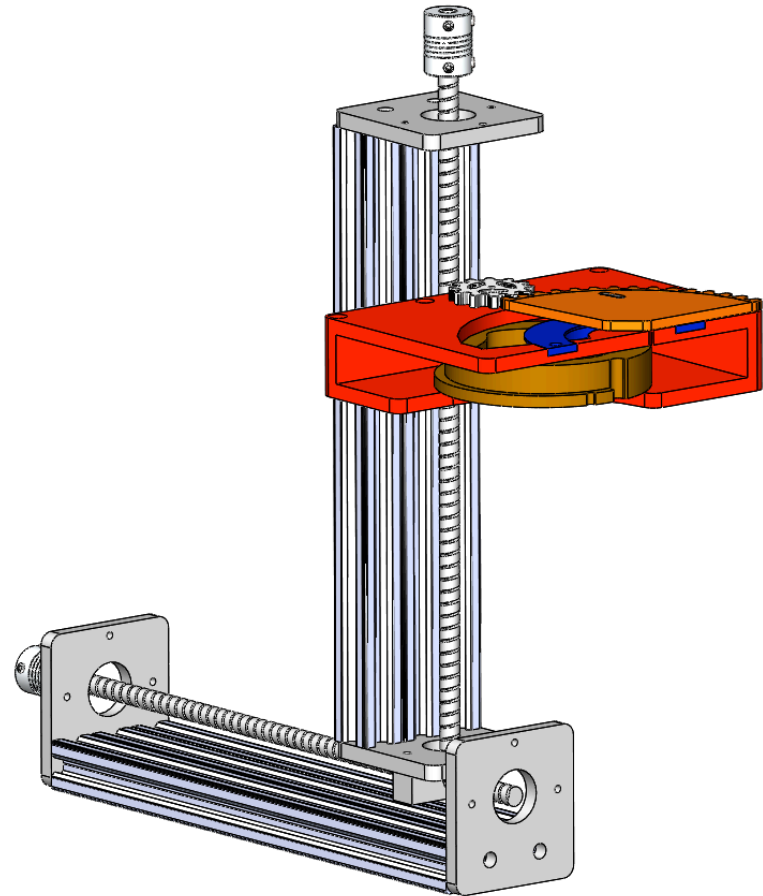

Assembly

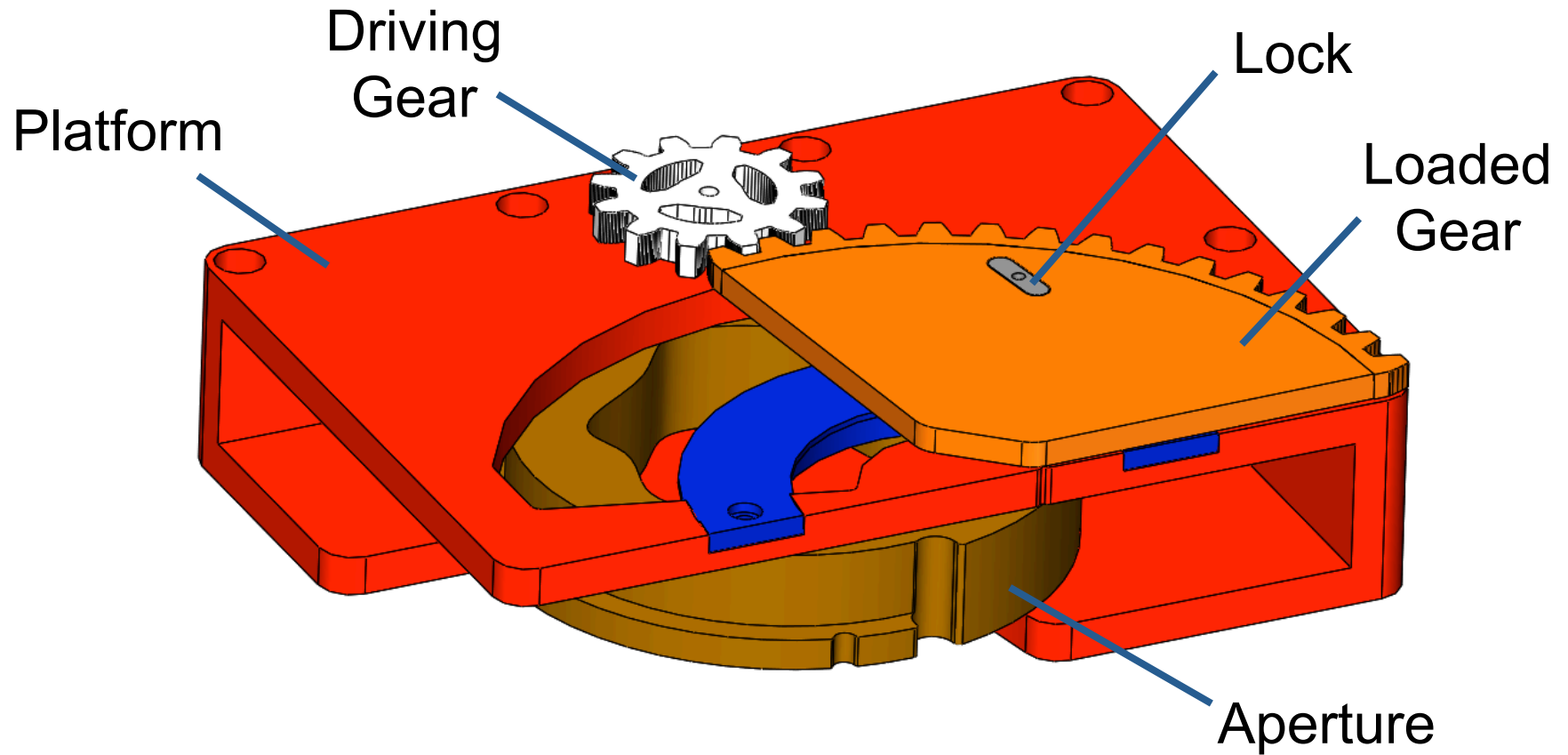

Parts

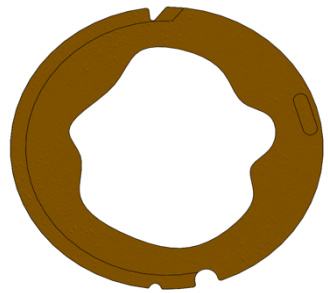

Aperture

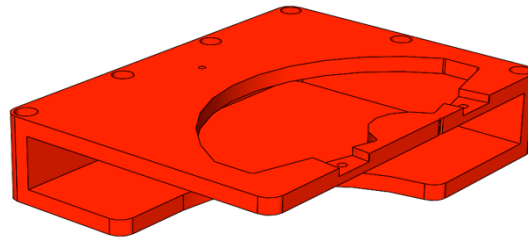

Platform



Lock

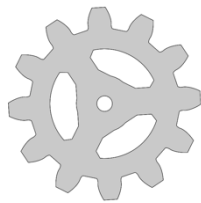
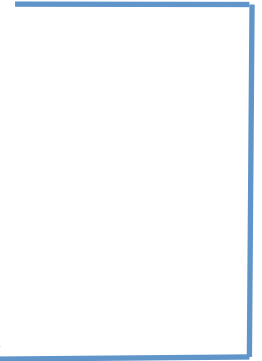

Driving Gear

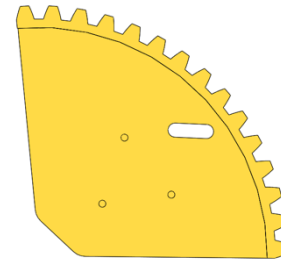

Loaded Gear



Loading Process

- Please see video.

System Overview

Microcontroller:

- ATmega2560
- 54 Digital I/O
- 16 Analog I/O

Implementation:

- Manual Operation
- Automatic Operation

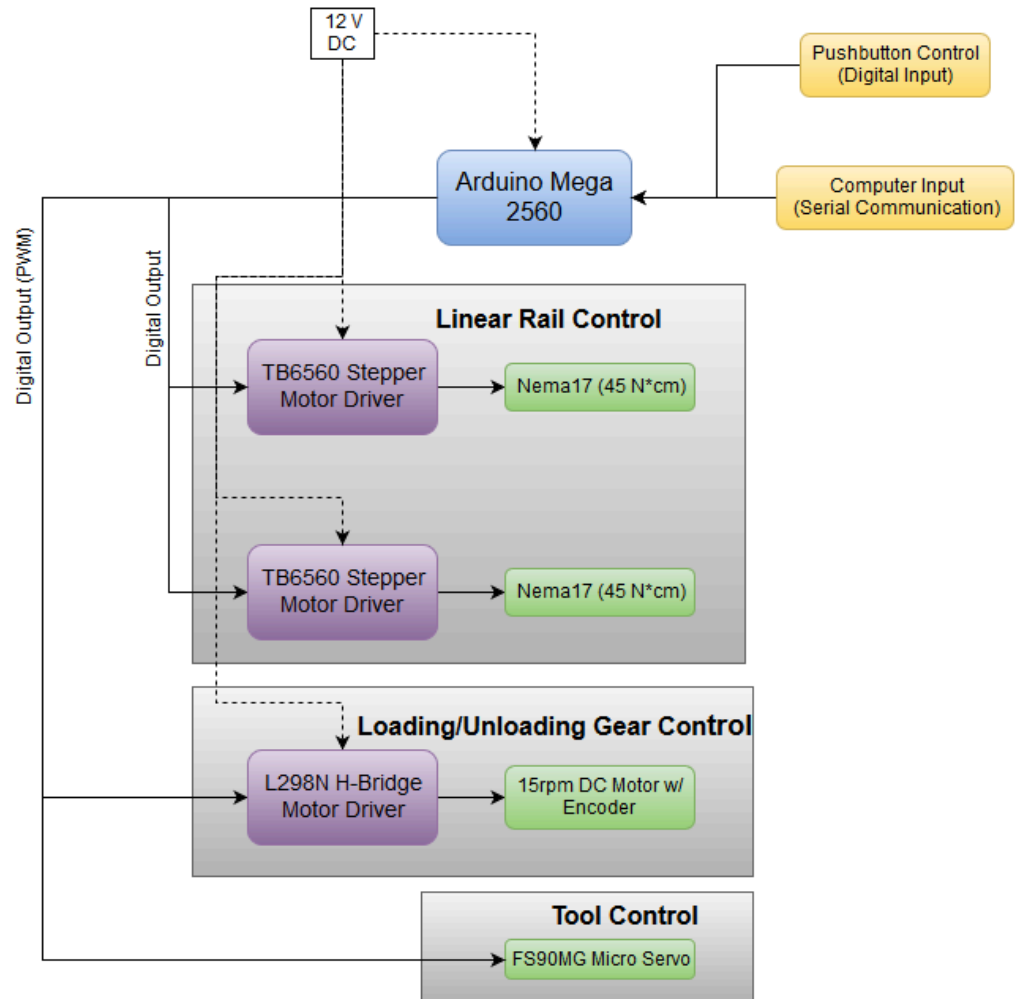

Automatic Operation

1. User selects which aperture(s) to load (loading instructions are sent to MCU)
2. System unloads/loads apertures (signal is sent upon completion)

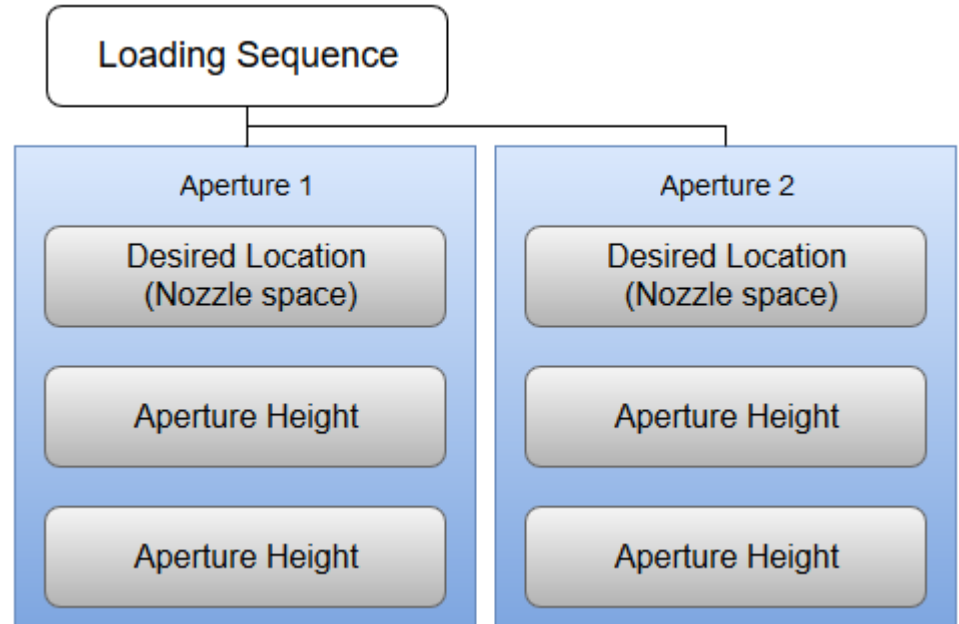

Power

Power Supply: 12V 30A DC (360W)

Component	Voltage	Current Draw	Power Consumption
Mega2560	12V	25mA	0.3W
Nema17(2x)	12V	1A	24W
15rpm DC motor	12V	750mA	9W
FS90MG Micro Servo	12V	500mA	6W
			39.3W

Future Work

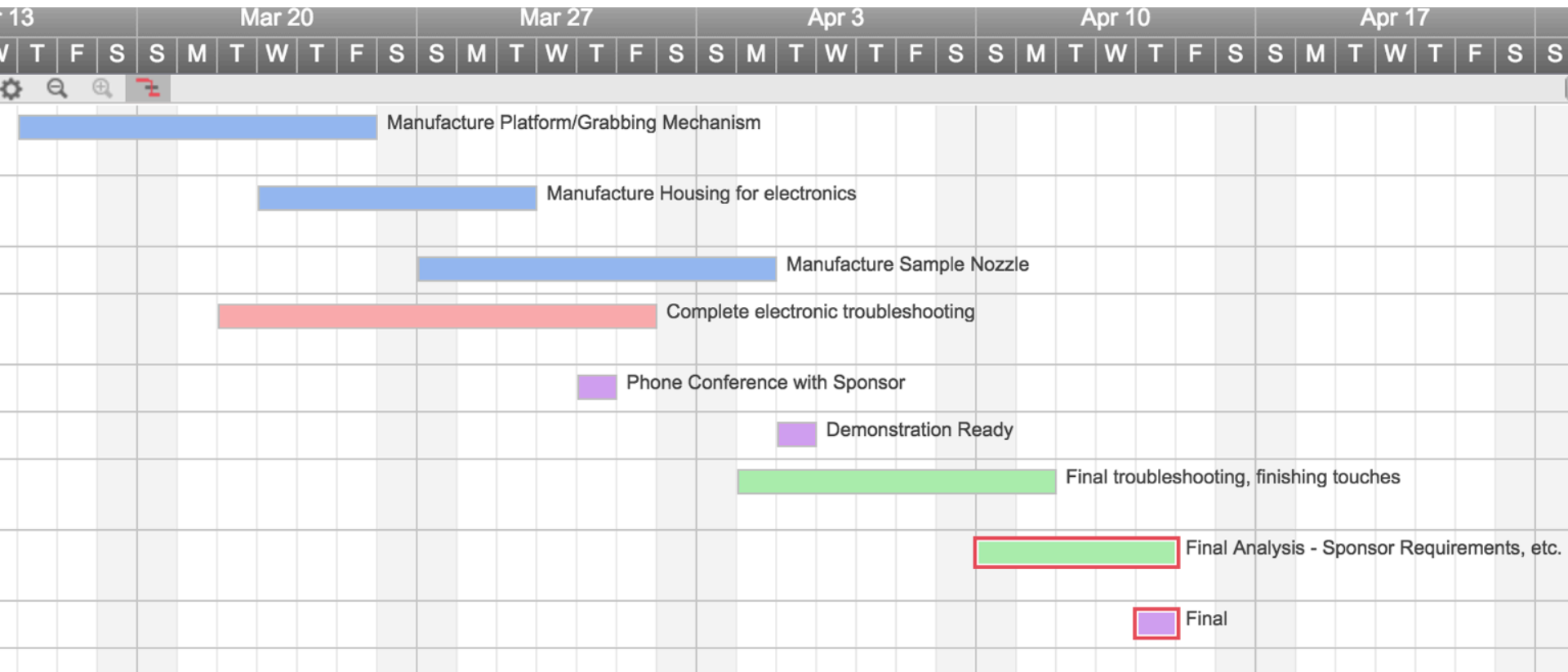

Budget

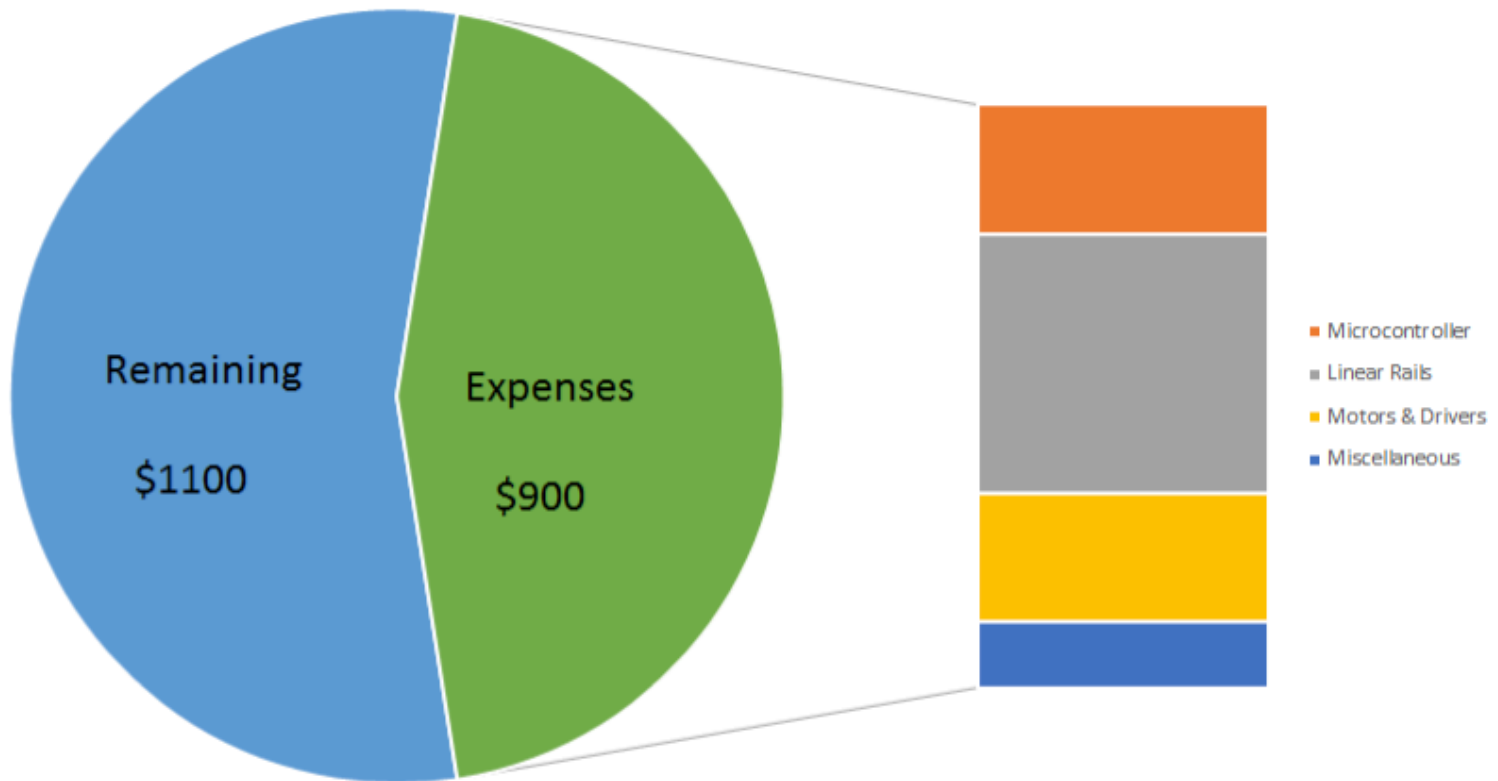

Summary

- Dot decimal has requested an automated loading system
- The chosen design concept solves the loading/unloading problems
- Future Work
 - Manufacture platform and nozzle for testing
 - System assembly
 - Finalize program structure and MCU communication

Questions

