

TEAM 13 - NO-CONTACT GAP MEASUREMENT DEVICE

Samuel Giaquinto

Matthew Nagy

Forrest Parker

Sponsor - Dr. Zheng; Advisor - Dr. Shih

ROLLING MACHINE²



Figure 1. Rolling Machine



Figure 2. Looking down on rollers



Figure 3. Safety Feature

Presenting:
Sam G.

NEED STATEMENT AND GOAL STATEMENT

Need

- The current use of feeler gauges to gap a pair of rollers is unreliable, time consuming, and potentially damaging.

Goal

- A non-invasive way of measuring the distance needs to be created.

PRO-E MODEL

- Pro-E model with all relevant dimensions.
- Only the important dimensions needed for the design.
- To scale.
- Measurements taken from the machine.

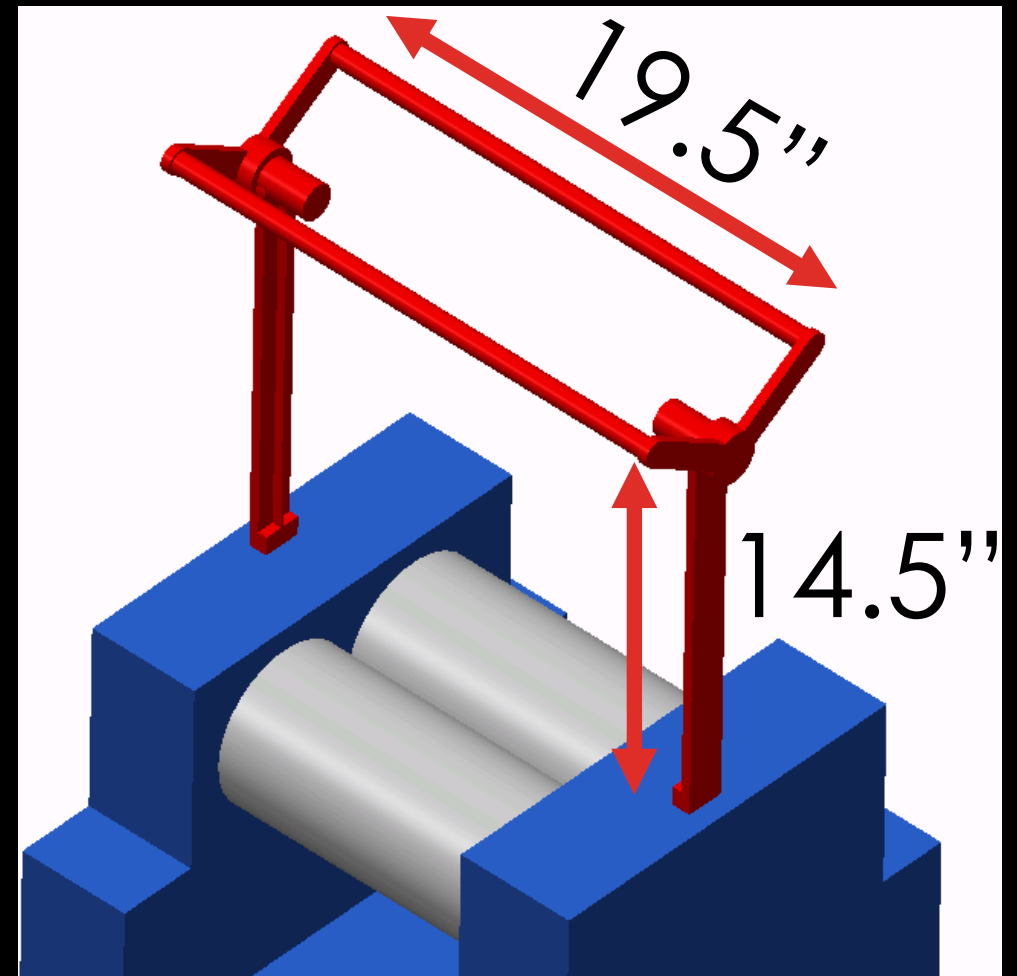

Figure 4. Pro-E Model of Machine

Presenting:
Sam G.

OBJECTIVES

- Maximize maneuverability in the applied system.
- Use optical sensors to measure the gaps of the rollers up to two microns.
- Can be removable or detachable and easily reassembled.
- No contact with the rollers themselves.
- System must have resistance to heat (rollers heat up to 300 Celsius)
- Reliable with a life of up to ten years.

Presenting:
Matt N.

CONSTRAINTS

- Total Cost: \$1,400
- Non-invasive.
- Light enough for the machine to hold it.
- Precise and purely accurate.
- Two micron resolution.
- Simple installation/takedown if needed.
- Internal power source; cannot be connected to machine.

Presenting:
Matt N.

HOUSE OF QUALITY ⁷

		Engineering Characteristics						
Customer needs	Importance	Material	Precision	Portability	Durability	Software/User Compatibility		
No Contact	5	1	5	5	1	2		
Easily Maneuverability	3	3	1	5	2	1		Key
Able to Perform in High Heat Environment	2	5	3	1	5	2		5 - Strong Relationship
Accuarte Readings	4	1	5	2	1	5		1 - Weak Relationship
Internal Power Source	1	1	4	5	2	2		
	Priority Σ (Importance* Rating)	29	58	55	27	39		
	Ranking	4	1	2	5	3		

Presenting:
Matt N.

Figure 5. House of Quality

DESIGN CONCEPT - LASER SENSOR

- Laser mounted on the red bars above.
- Shine the laser down through the gap in the rollers.
- Measure the amount of light that shines through.
- Compare the amount of light to the intensity of the beam that was fired.
- From the ratio, the distance between the rollers can be acquired.

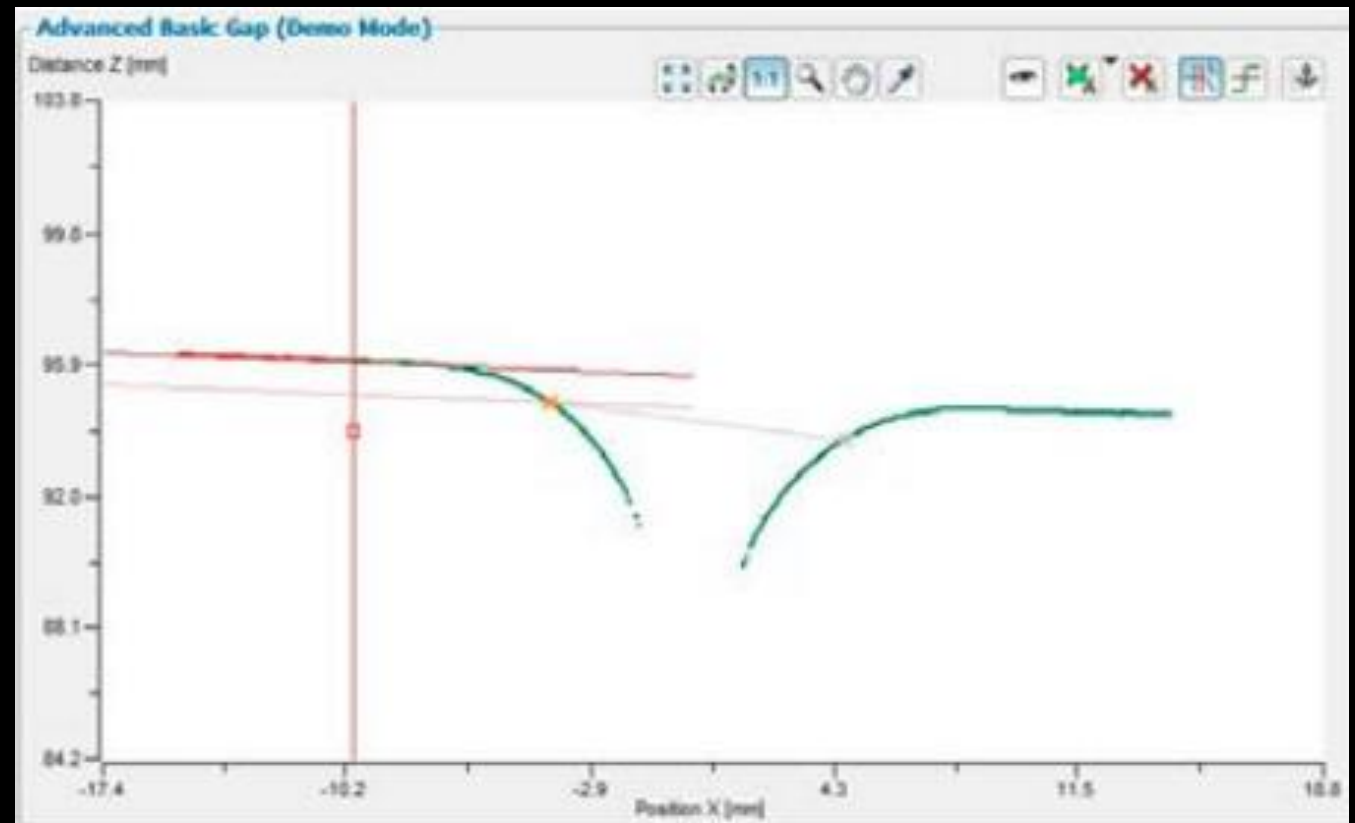

Figure 6. Laser triangulation Data

Presenting:
Sam G.

VICKERS HARDNESS TEST

- Design concept inspiration
- 136° indenter is pressed into the sample by a controlled force
- The size of the indent is determined optically by measuring the two diagonals of the square indent.
- $HV = \text{Constant} \times \text{test force} / \text{indent diagonal squared}$

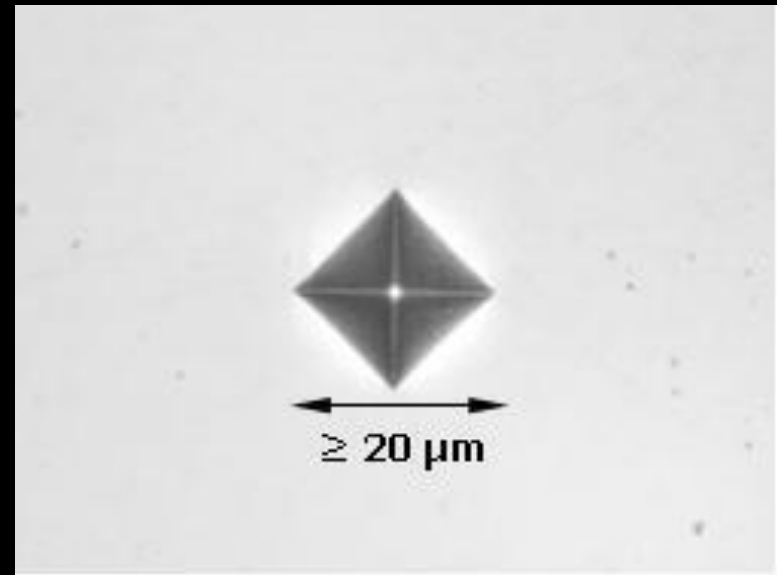

Figure 7. Indentation measurement

DESIGN CONCEPT – HIGH RESOLUTION DIGITAL PHOTOGRAPHY

- Camera mounted on the red bars above.
- Zoomed enough to be able to take a clear picture.
- Black sheet (or other noticeable color) placed underneath to help visibility.
- Zoom level known.
- Use algorithm to find the distance with the zoom level and the photograph.
- Example: Kalu's *Mechanics and Materials II* Vickers Hardness Lab

Presenting:
Forrest P.

PHOTO-MICROSCOPY¹¹

Main challenge:
Focusing on a 80-200 micron gap
from 6-18 inches away



Figure 8. Raspberry Pi Camera

Design Concept:
Using M12 lenses on camera to
achieve desired focal length



Figure 9. M12 Lense Mount

Presenting:
Forrest P.

CHALLENGES AND RISKS

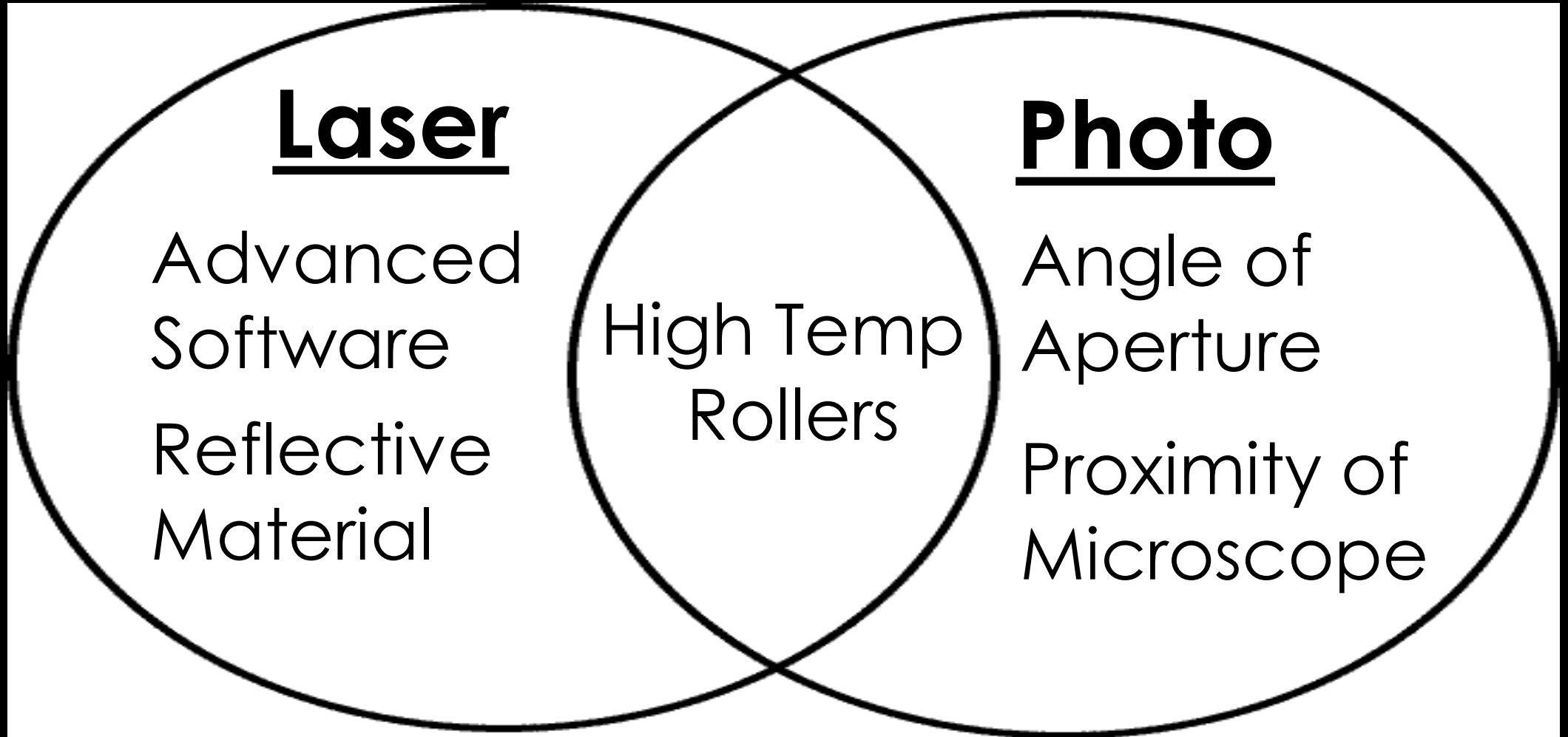

BRIEF FUTURE PLANS OUTLINE

- October
 - Finalize design concepts
 - Pick final design
- November
 - Budget analysis
 - CAD design and simulation
- December
 - Order parts
 - Begin product testing

Presenting:
Matt N.

GANTT CHART

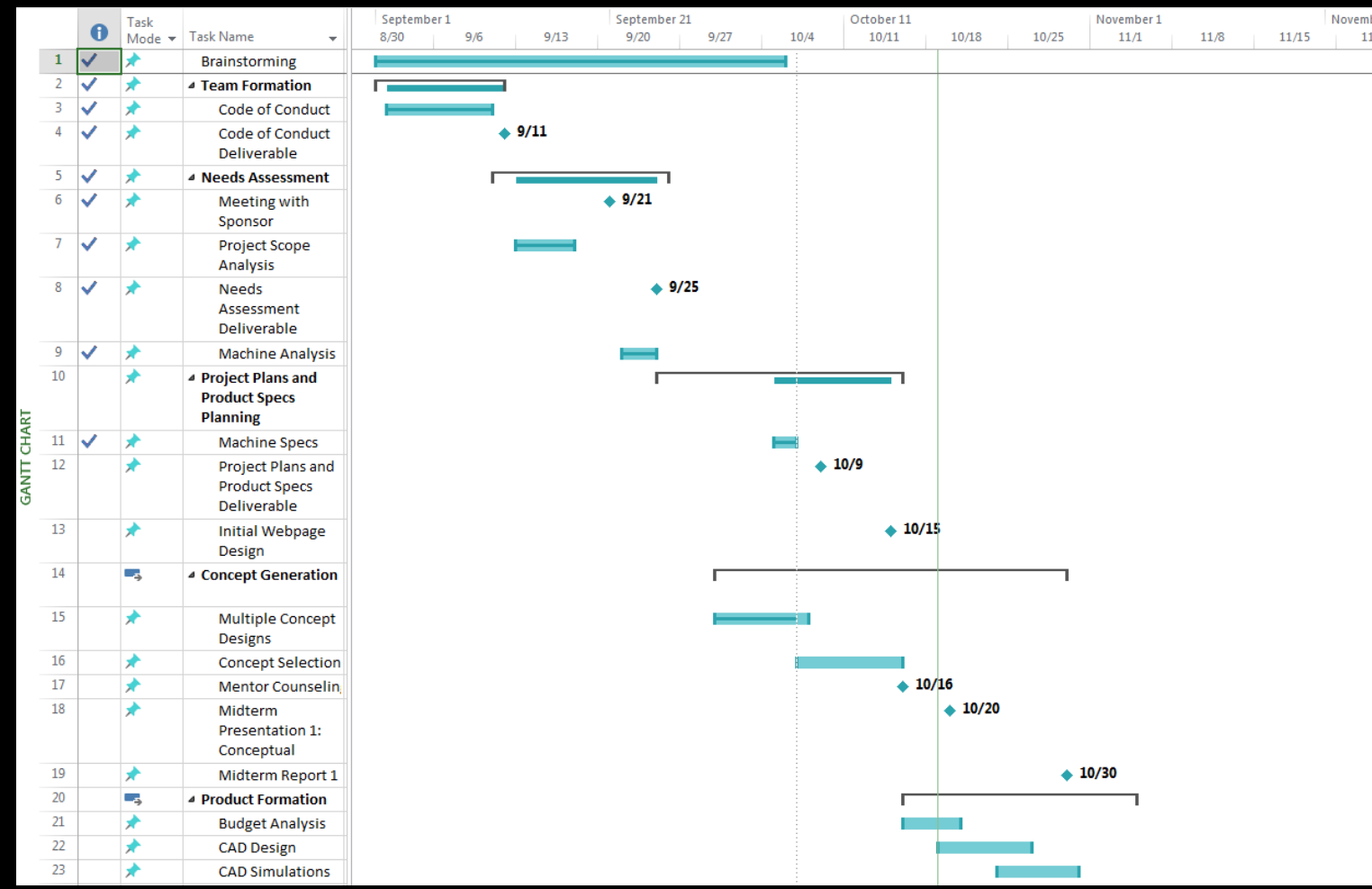

Presenting:
Matt N.

Figure 11. Gantt Chart

SUMMARY

- Identified the need for the no-contact gap measurement for rolling machine.
- Address the objectives and constraints of the project.
- Set up a House of Quality to determine important engineering characteristics.
- Looked into two different potential designs.
- Identified challenges and risk of each design.
- Set up a Gantt chart to prepare for future project plans.

Presenting:
Matt N.

REFERENCES

- <http://www.micro-epsilon.com/download/products/dat--gapCONTROL--en-us.pdf>
- http://wiki.raspberrytorte.com/index.php?title=File:CloseUpCameraModuleRev1_3.jpg
- <http://www.directindustry.com/prod/third-dimension/product-16646-217545.html>