

# Operations Manual

## Team 8

### Design an Unmanned Tilt-Rotor Aircraft for Multi-Mission Application



#### Members:

Kade Aley – [Ka11d@my.fsu.edu](mailto:Ka11d@my.fsu.edu)

Jake Denman – [Jad13h@my.fsu.edu](mailto:Jad13h@my.fsu.edu)

Daylan Fitzpatrick – [Df12b@my.fsu.edu](mailto:Df12b@my.fsu.edu)

Christian Mård – [Cam11y@my.fsu.edu](mailto:Cam11y@my.fsu.edu)

Patrick McGlynn – [Pam09e@my.fsu.edu](mailto:Pam09e@my.fsu.edu)

Kikelomo Ijagbemi – [Kikelomo1.ijagbemi@fam.u.edu](mailto:Kikelomo1.ijagbemi@fam.u.edu)

#### Faculty Advisor:

Dr. Farrukh Alvi

#### Sponsor:

Dr. Chiang Shih

#### Instructor:

Dr. Nikhil Gupta

04/01/2015

# Table of Contents

<b>Table of Figures.....</b>	<b>iii</b>
<b>Table of Tables .....</b>	<b>iv</b>
<b>1. Functional analysis /Functional Diagram.....</b>	<b>v</b>
<b>2. Project / Product specification.....</b>	<b>vi</b>
<b>3. Product assembly .....</b>	<b>vi</b>
<b>4. Operation instructions.....</b>	<b>xi</b>
<b>5. Troubleshooting .....</b>	<b>Error! Bookmark not defined.</b>
<b>6. Regular Maintenance.....</b>	<b>xiv</b>
<b>7. Spare parts / Inventory.....</b>	<b>xv</b>

## Table of Figures

Figure 1 - Conceptual Design .....	vi
Figure 2 - Cobra 4510/28 Kv Motors .....	vi

## Table of Tables

**No table of figures entries found.**

# 1. Functional Analysis

The function of this project is to create a Vertical Take-Off and Landing (VTOL) aircraft that will be successful in competition. This project was intended to attend the Association for Unmanned Vehicles Systems International (AUVSI) Student Unmanned Aerial Systems (SUAS) competition. However, attending the competition was not possible due to the AUVSI committee closing registration a month earlier than stated. Team 8 lacked the raw funding initially to register for the competition.

To satisfy the VTOL requirement, Team 8 came to the conclusion that an integral design would be the most effective. Using this ideology, the concept of a multirotor integrated within a flying wing was generated. The multirotor aspect allows the craft to have VTOL characteristics, while the flying wing allows for efficient horizontal flight. Rather than having dedicated propulsion systems for both aspects, Team 8 wanted to use one propulsion system for both. This is possible by the rotation of the front motors. Utilizing this method reduces the amount of dead weight on the Unmanned Aerial Vehicle (UAV) which increases the overall efficiency and flight time. These aspects are very important for the SUAS competition.

This design is able to function properly thanks to the compatible nature of our flight controller, the 3DR Pixhawk. This piece of hardware allows the switching of flight modes (vertical/horizontal) to be possible. Other systems require separate flight controllers for each aspect of flight.

## 2. Project Specification

The airframe is composed of two major systems, the tri-copter and the fuselage. The tri-copter frame is integrated to the fuselage using in-house laser cut ABS plastic and provides structural support for the propulsion systems. The fuselage is the Skywalker X8, a flying wing without a tail section. This fuselage provides both a desirable lift and payload capacity.

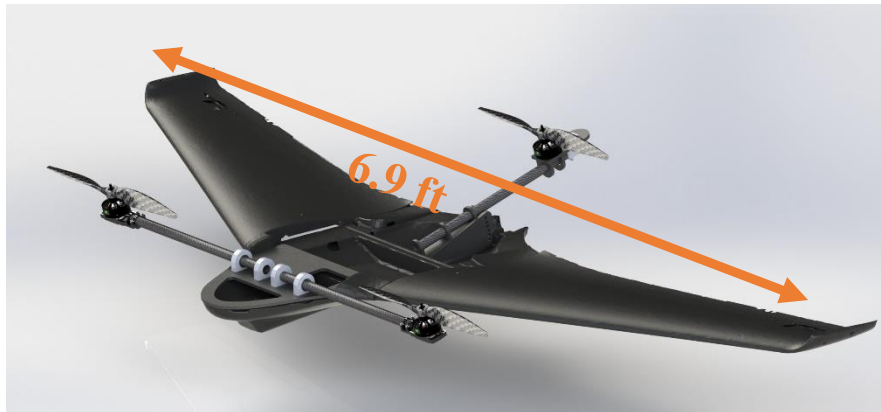

**Figure 1 - Conceptual Design**

The motors chosen for this aircraft were the Cobra 4510/28 Brushless motors, shown in Figure 2. These motors are 420kv motors, meaning that they revolve 420 times a minute for every volt supplied, which equates to roughly 155 times a second (with 22.2V battery). These motors have a maximum continuous current of 35 Amps; this value will be essential in the selection of our motor controller. This motor allows for both 5-Cell & 6 Cell LiPo power systems, meaning it is limited to either 18.5 volt or 22.2 volt lithium polymer batteries. With these specifications from the motor, the most efficient propeller was selected from a chart found in previous reports, which was a 16x5.5in carbon fiber propeller, not pictured.



**Figure 2 - Cobra 4510/28 Kv Motors**

These motors, and thus propellers, are powered by Electronics Speed Controllers (ESCs) which are powered by the two 22.2V 5000mAh batteries on board. The batteries supply the power to the ESCs which then decide the proper amount of voltage to apply to the motors themselves, according to the signal sent from the microcontroller.

The Pixhawk is an all-in-one flight controller capable of stabilization and autonomous flight. The controller itself is being constantly expanded through its open source development. This open source development gave this project the ability to expand upon previously made VTOL firmware, and to allow the group to go forward with the tilt-rotor design.

Some of the key features of the Pixhawk include a 168 MHz / 252 MIPS Cortex-M4F, which is more than sufficient for this design, and 14 PWM / Servo outputs, which can accommodate all of the servo, motor, telemetry, and peripheral connections that will be included. There are multiple forms of recovery built into the firmware so that the craft will always be flying in some form, and provides a transition from autopilot to manual. It includes all of the basic sensors required by most flight projects, such as a gyroscope, accelerometer, magnetometer, and barometer. It also allows for the addition of other systems like a GPS module for waypoint navigation and Telemetry to receive data back in real time.

All of the servos in this design are digital, allowing them to react faster to outside stimulus, like wind resistance during flight. This is important in helping the aircraft's microcontroller maintain stability in a constantly changing environment. Each Hitec HS-5625MG servo produces 131 oz.-inches of torque, which is well in excess of the minimum torque required of 59.902 oz.-inches, from the elevons, when the aircraft flies at 50 miles per hour. The minimum torque required for the elevons was found by calculating the drag on the elevons surface. While the tail tilt platform only requires 33.845 oz.-inches and the front tilt bar requires 87.091 oz.-inches, both use the Hitec HS-5645MG servo, which produces 168 oz.-inches of torque. The minimum torque required for the front tilt bar and tail tilt platform was calculated using the weight of the parts in reference to the axis of rotation. These calculations can be found in the appendix.

### 3. Product Assembly

This operation manual gives directions on how to integrate the tri-copter frame within the Skywalker X8 flying wing. The tri-copter frame is composed of the Front Mount, Front Tilt Bar, Rear mount, and the Yaw Control Mount.

#### A. Front Mount

The front mount is responsible for securing the Front Tilt Bar and will be tied into the future modular mounting system. The motor is joined to the carbon fiber rod via the laser cut ABS motor mounts. Next, the carbon fiber rods are coupled with a hollow aluminum tube. Both of the carbon fiber rods and coupler sit inside of 4 bearings. Two roller bearings on the outsides and two ball bearings in the center. These bearings are housed in laser cut ABS mounts which are press fitted and epoxied to the front plate. The last component of this sub assembly is the servo mounting and 4-bar linkage which translates the rotation of the servo to the rotation of the tilt mechanism.

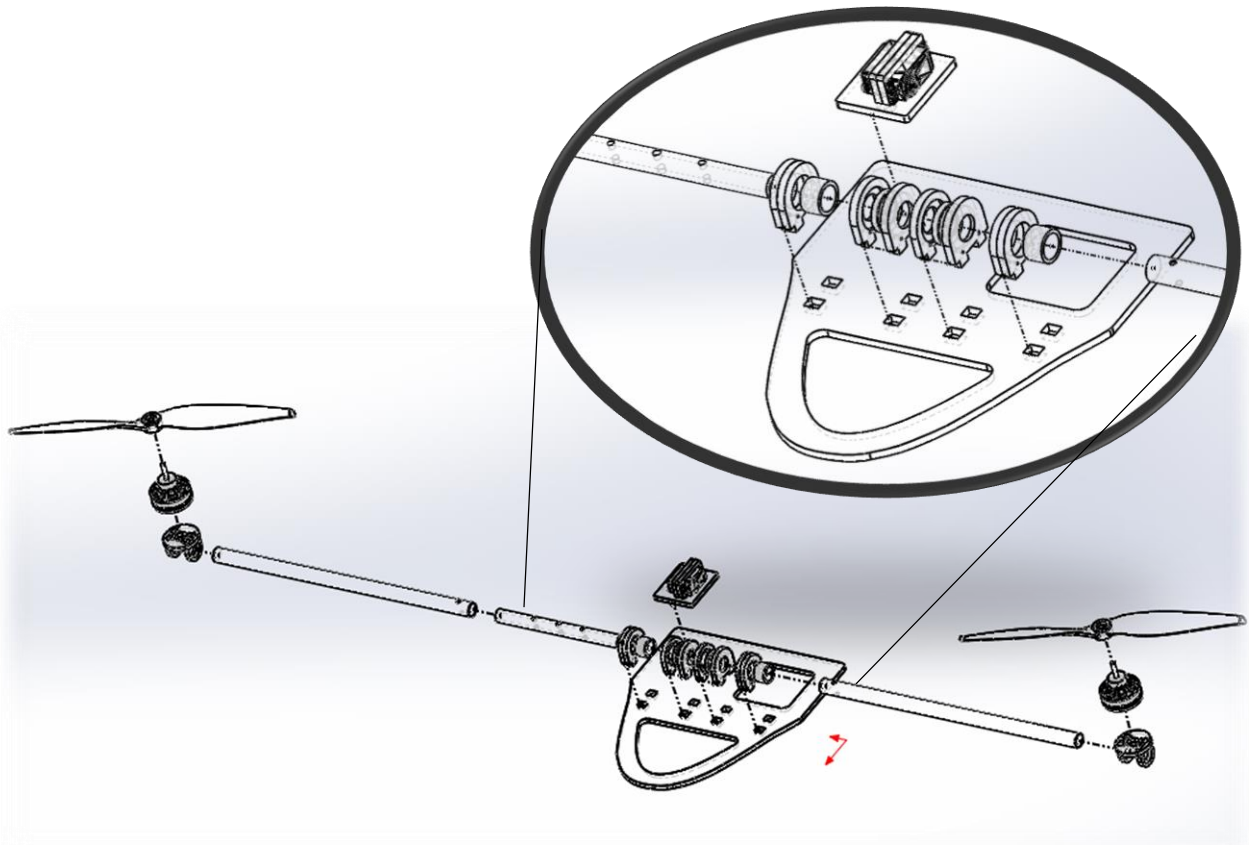
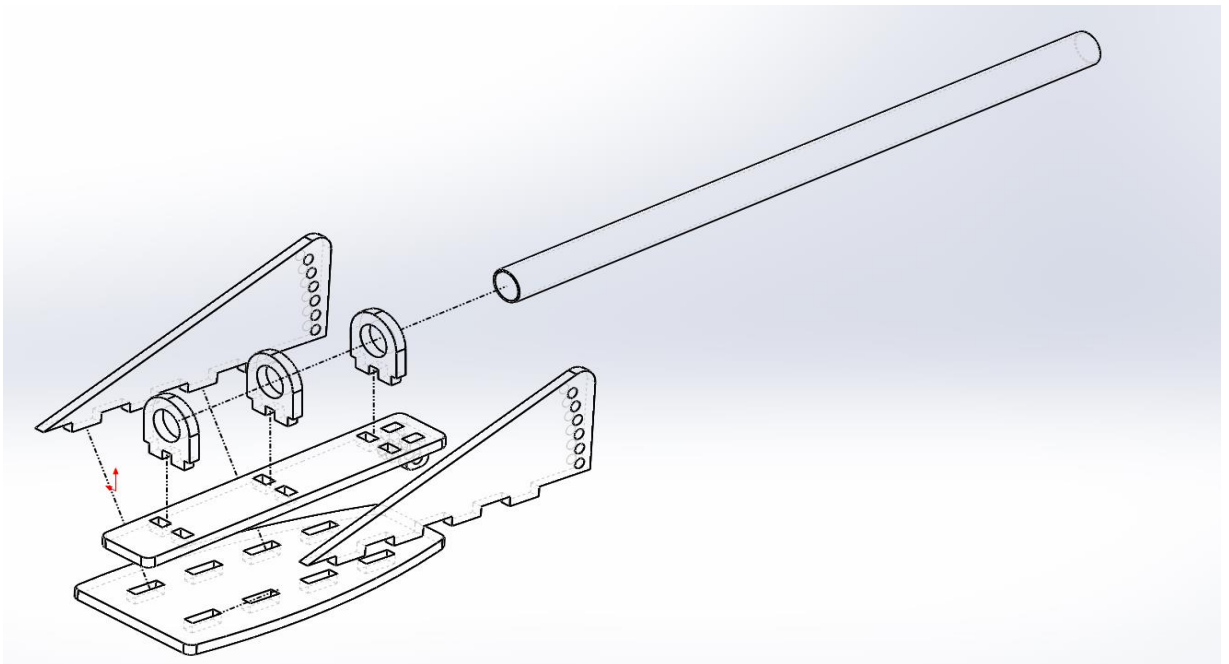

**Figure 3 - Front Mount**



## B. Rear Mount

This mount brings the rear yaw assembly and the fuselage together. It is secured to the fuselage via foam adhesive and secured to a “sandwiching” plate outside of the body. This mount is fully constructed of laser cut ABS plastic. The bottom plate is secured to the fuselage and the middle plate is secure via a revolute pin to the bottom plate. This allows for the middle plate adjust angles, thus the pitch of the rear motor.



**Figure 4 - Rear Plate**

### C. Yaw Control Mount

This yaw mount attaches to the above rear mount via the carbon fiber tube. This mount allows the motor to rotate along the carbon fiber tube. This is done through articulation from the servo which is mounted inside the mount. The mount is connected via the servo connection and the bearing mount located centrally as seen below.

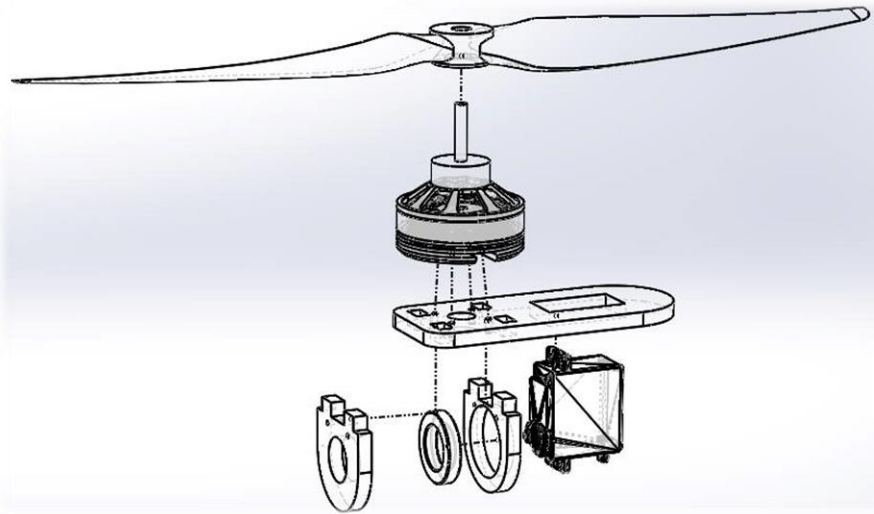

**Figure 5 - Yaw mount**

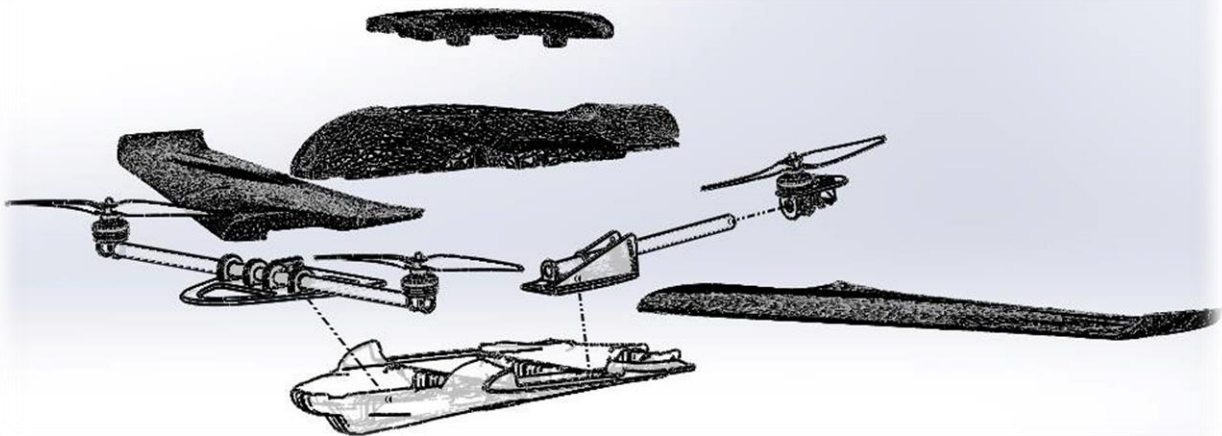

**Figure 6 - Full Aircraft Assembly**

# 4. Operation instructions

## AIRCRAFT OPERATION

To operate the aircraft, install the firmware on an operating system. This is available at <http://dev.px4.io/starting-building.html>. Aircraft operation is composed of three parts: Pre-flight operation, flight operation, and post-flight operation.

Warning: Take the following precaution before executing the operation instructions.

- i) All propellers should be detached until aircraft is ready for flight.
- ii) Batteries should be unplugged until aircraft is ready for flight.
- iii) Ensure flight area is clear of obstacles.
- iv) Never fly close to people and in case of emergency, avoid crashing into people or objects.

### A. PRE-FLIGHT INSTRUCTION

- i) Perform an inspection on the aircraft frame. Check the wings to ensure they are firmly attached.
- ii) Ensure the three motors are not loose. Spin the motors and tilt the front bar to ensure they rotate and tilt freely. Tilt the rear mount so that the motor points upwards.
- iii) The Pixhawk and all other components within the frame should be firmly positioned in the aircraft. Check for damages in the wiring.
- iv) If there are no damages, ensure all wires from servos and motors are correctly plugged to the right ports on the Pixhawk.
- v) Test the functionality the ailerons and elevators by using the transmitter. If they don't respond, check the connections.
- vi) Activate the aircraft through QGroundControl or the transmitter. Link the Pixhawk to QGroundControl through the MAV link or 3DR Telemetry kit.
- vii) The firmware should be installed on the aircraft so that onboard sensors like GPS, barometer, gyroscope, and magnetometer can be calibrated. If they have yet to be calibrated, follow the instructions on QGroundControl to do so (this includes moving the craft around in various positions, so have a wide area to work with).
- viii) If parts have been moved around, ensure the plane still has a stable center of gravity.
- ix) Arm the aircraft by pressing the red button located near the wing. It can be armed wirelessly with the Mission Planner software. Then, hold the throttle in the down-left corner to fully arm the craft. After this, the aircraft is ready for vertical takeoff.

### B. IN-FLIGHT INSTRUCTIONS

The aircraft can be flown autonomously, manually or both. This aircraft can also perform vertical and horizontal takeoff and landing, though it is recommended that it only take off vertically. With vertical takeoff, also known as tri-copter mode, the motors on the front bar are pointed upwards and rotate in opposite directions to counter each other's moment. The back motor rotates in the direction of one of the front motors.

The immediate lift off of the ground might seem unstable, but will balance out when it has reached an adequate height. Make sure to climb to a safe height before a transition, to avoid collision with any low objects. When the craft is high enough, it can be transitioned

into the Transition Phase by rotating the AUX3 knob (located on the top right of the transmitter). This will cause the front bar to tilt forward and create horizontal thrust.

When the aircraft has gathered enough speed, which can be sensed by the airspeed sensor, the aircraft transitions to the horizontal flight mode. This should disengage the motors the back motor and active the elivons.

To land the aircraft, the flight mode needs to be changed back to vertical flight by rotating the same knob in the reverse direction. The back motor should reactivate and the front bar returns to its upward state. Landing should be done slowly to prevent damaging the plane.

#### i) Manual

In manual flight mode, the plane is controlled by the transmitter (remote control). An experienced R/C pilot should be at the control if this mode is to be used. The pilot should ensure a stable flight path while navigating the aircraft. The time of flight should be recorded as the batteries will only supply around 15 to 35 minutes (depending on the mode of the aircraft). Keep an eye on the battery percentage, as the user will have to manually land the plane before it runs out of power. Someone should be monitoring QGroundControl when the aircraft is airborne, and this operator should observe the battery charge, camera feed, GPS coordinate, orientation, etc.

#### ii) Autonomous

In autonomous flight mode, the aircraft is no longer controlled remotely. It moves towards its first waypoint regardless of its current position. When Auto is engaged, the pilot loses control of the throttle and elevators (pitch), and Pixhawk will be engaged. The microcontroller will take the aircraft to the preprogrammed waypoints. With the connected 3DR telemetry radio, the operator at the ground station can remotely instruct the Pixhawk to fly in a particular direction.

### C. POST FLIGHT MODE

- i) After the aircraft is disarmed, disconnect the batteries to avoid powering the motors. Caution should be taken to ensure the propellers are not engaged, this can be injurious.
- ii) After the power is disconnected, the propellers may be removed from the three motors.
- iii) Electrical components such as the APM and 3DR telemetry kit should be unplugged.
- iv) Transport carefully to a safe place to minimize damage.
- v) Do not store a battery when it is empty. Make sure the battery is charged before storing.

# 5. Troubleshooting

## 5.1 Firmware

### A) Files Not On Board

- 1) The Upload File option on QGroundControl will not add files to the board.
- 2) Ensure that the custom Autostart file has been added to the ROMFS/px4fmu\_common/init.d folder, and that the Mixer files have been added to the ROMFS/px4fmu\_common/mixers folder.
- 3) Upload the firmware via the make/build commands on the Ubuntu terminal.

### B) QGroundControl Does Not Recognize Pixhawk

- 1) Ensure a complete USB connection to the Pixhawk board during the upload process.
- 2) Do not update the firmware directly from QGroundControl (unless the default firmware is desired).
- 3) Ensure that the Autostart file and the Mixer files are free of syntax errors. They must follow the same format as the rest of the files. Try copying a working file and adding the custom code. Try removing the less necessary lines to locate the error.

### C) Cannot Calibrate Level Horizon

- 1) Check to make sure the custom Firmware files are in the correct destinations. See troubleshoot for Firmware A-2 (Files Not On Board).
- 2) Make sure the Firmware files are free of errors. See troubleshoot for Firmware B-3 (QGroundControl Does Not Recognize Pixhawk).

### D) Make/Build Process Has Halted

- 1) Unplug and reconnect the USB. If no response, hold Ctrl and press C (Ctrl + C) to end the terminal process. Restart the Firmware update process.

## 5.2 Control

### A) Unresponsive to Controller

- 1) Arm the craft from the board using the red button connected to “Swiith”.
- 2) Active the second arming phase by holding the throttle to the lower right.
- 3) Ensure both the craft and the controller are adequately charged.

### B) Back Motor Does Not Turn Off During Transition

- 1) Ensure the correct connection from the back motor to the correct Main output on the Pixhawk (MainOut 3 according to current firmware).
- 2) If the Autostart file has changed, make sure the physical connection matches the VT\_FW\_MOT\_OFFID variable.

### C) Front Motors Shut Off After Transition

- 1) Ensure the throttle on the controller is not lowered.

### D) Pixhawk Is Unresponsive

- 1) If the main LED is lit red, it is likely that the Pixhawk needs to be calibrated.
- 2) If the Pixhawk is already calibrated, the following errors are possibilities: Flaw in the custom firmware, batteries not charged, or SD card is missing.

## 6. Regular Maintenance

### A) Batteries

- 1) Store between 50-70% charge in lipo bags
- 2) Check voltages before usage

### B) Wiring

- 1) Check for damages or kinks in the connections
- 2) Ensure all connections are complete and not separated

### C) Calibration

- 1) Calibrate on-board sensors after updating firmware

## 7. Spare parts / Inventory

- I. General
  - a. Skywalker X8 Fuselage
  - b. Extra wiring
  - c. Carbon Fiber rod (19.75in)
- II. Tools
  - a. ECG Soldering Iron
  - b. Vicegrip
  - c. Dremel 300 + Kit
  - d. Surebonder Pro4000A Hot Glue Gun
  - e. Stanley FatMax Utility Knife
  - f. Hammer (x2)
  - g. Pliers + Screwdriver Set (Grey Box)
  - h. Allen Wrench Set
  - i. Wire Cutter (x3)
  - j. Pliers (x2)
  - k. Wrench Set (loose)
  - l. Screwdrivers (x3)
  - m. Pro's Kit MT-1210 Multimeter
- III. Receivers
  - a. Spektrum DX5e
  - b. Futaba T6J
  - c. Iris FS-TH9x
- IV. Batteries
  - a. Zippy Compact 2200 7.4V Battery
  - b. Zippy Compact 2200 11.1V Battery
  - c. Turnigy Nano-tech 2.2 11.1V Battery (x2)
  - d. Turnigy 1.0 11.1V Battery
  - e. FMS 7.4V Battery
- V. Chargers
  - a. Lipo/LiFe Balance Charger
  - b. Hobbico TorqMaster 90-deluxe 12 volt starter
  - c. Thunder Power Lithium/Polymer Charger (TP-535)
  - d. Helion Charger (9.6V DC 35mA)
  - e. Primal Multi-Chemistry AC Peak Detection Balance Charger
  - f. Balance Charger V6AC
  - g. Prophet SPORT II
  - h. HITEC Multi Charger (X4 AC Plus)
- VI. Propellers

- a. RC TIMER 16x5.5" propeller (x5)
- VII. Servos
  - a. Hitec HS-485HB
  - b. Futaba S3003
  - c. Extra servo parts
- VIII. Landing Gear
  - a. 5.00 127mm Tire (x2)
  - b. 6.00 Inflatable Tire
  - c. 2.50 64mm Tire