

# Final Report

## Team 6

### Applying Noise-Reduction Techniques to a Handheld Centrifugal Hairdryer

#### Members:

Shawn Eckert	sme13b@my.fsu.edu
Kiet Ho	kth13c@my.fsu.edu
Mark Johnson	maj12b@my.fsu.edu
Peter Van Brussel	pav11b@my.fsu.edu

#### Faculty Advisor

Dr. Cattafesta

#### Sponsor

Dr. Devine

#### Instructors

Dr. Gupta

Dr. Shih

#### Date Submitted

April 8, 2016

# Table of Contents

**Table of Figures**..... **i**

**Table of Tables** ..... **ii**

**ACKNOWLEDGEMENTS** ..... **iii**

**ABSTRACT**..... **iv**

**1. Introduction**.....**1**

    1.1 Project Scope ..... ..

    1.2 Standard Components of a Hairdryer ..... ..

        1.2.1 Background Research ..... ..

    1.3 Needs Statement..... ..

    1.4 Constraints ..... ..

**2. Experimentation**..... ..

    2.1 Observed “Quiet” Models..... ..

    2.2 Performance Testing ..... ..

    2.3 Sound Measurements ..... ..

**3. Results of Observed Models**..... ..

    3.1 Comparing Performance Results ..... ..

    3.2 Noise Analysis Overview ..... ..

    3.3 Noise Source Contributions ..... ..

    3.4 Design-Reasoning for Moving Forward ..... ..

**4. Design Modifications** ..... ..

    4.1 Implementing Test Data into Design Modifications..... ..

    4.2 Design of Components for Modifications..... ..

        4.2.1 Chevron Nozzle Tip..... ..

4.2.2 Centrifugal Fan Blade System .....  
4.2.3 Intake Baffles .....  
4.3 Results and Testing of Design Modifications .....  
4.2.4 Chevron Nozzle Tip .....  
4.2.4 Centrifugal Fan Blade System .....  
4.2.4 Intake Baffles .....

**5. Project Management.....**

5.1 Schedule .....  
5.2 Resources .....  
5.3 Procurement .....  
5.4 Communications .....

**6. Conclusion .....**

**References .....**

**Appendix A – Gantt Chart.....**

**Appendix B – Exploded View of Assembly.....**

**Appendix C – Measurements.....**

**Appendix D – CAD Drawings.....**

**Appendix E – Bill of Materials .....**

**Biography.....**

## Table of Figures

Figure 1: Standard components of a hairdryer.....	2
Figure 2: Image of axial fan of a simple hairdryer .....	3
Figure 3: Inside of centrifugal-type hairdryer.....	3
Figure 4: Centrix Q-Zone (Left) and Bio-Ionic Whisper Light (Right) .....	5
Figure 5: Pitot tube measuring total pressure of hairdryer jet (left) and an infrared thermometer measuring temperature change of the surface (right) .....	7
Figure 6: Sound-testing setup in the anechoic chamber .....	8
Figure 7: Heating element removed (left) and intake baffle removed (right).....	9
Figure 8: Velocity profiles of Centrix and Whisper on high speed (left) and velocity profiles of just the Centrix on both high and low speeds (right) .....	11
Figure 9: Frequency spectrum with an applied A-weighting filter (colored in green) .....	12
Figure 10: Graph pertaining to noise source contributions for the Whisper.....	14
Figure 11: Whisper Light fan mounting, before and after .....	15
Figure 12: Chevron shows early mixing of outgoing fluid.....	16
Figure 13: Chevron Nozzle applied to Whisper, before and after .....	17
Figure 14: Chevron Nozzle up-close .....	17
Figure 15: Original Fan recreated in SolidWorks.....	18
Figure 16: SLS 3D printing process.....	19
Figure 17: 3D-Printed Centrifugal Fan Blades (1: Original Blade, 2: FDM 3D-printed of original, 3: SLS 3D-printed of Original, 4: SLS 3D-printed with reduced number of blades).....	20
Figure 18: Angled view of Intake baffles .....	21
Figure 19: 3D-print Intake baffle designs.....	22
Figure 20: Static balancing on a pin .....	24
Figure 21: Static fan balancing on a prop balancer.....	25

Figure 22: Noise testing location schematic ..... 26

Figure 23: Breakdown of team 6’s budget of \$1,500 ..... 28

Figure 24: Exploded view of the fan fitted within a basic replica of the Whisper ..... 35

Figure 25: Intake Baffle Part 1..... 37

Figure 26: Intake Baffle Part 2..... 38

Figure 27: Intake Baffle Part 3..... 39

Figure 28: Chevron Nozzle Tip ..... 40

## Table of Tables

Table 1: Comparing performance of Centrix Q-Zone and Whisper Light .....	10
Table 2: Baffle Design Specifications .....	22
Table 3: Baffle Noise measurement, A-weighted.....	26
Table 4: Measurement Values for Specific Parts of the Redesigned Fan Blade System.....	36
Table 5: Measurement Values for Specific Parts of the Chevron Nozzle .....	36
Table 6: Bill of Materials .....	41

## ACKNOWLEDGEMENTS

The team would not have successfully made this project come to fruition without the help of these honorable mentions: Dr. Nikhil Gupta, Dr. Louis Cattafesta, Dr. Michael Devine, the employees of *Function 3D*, the employees of *3DSystems*, and FSU's College of Engineering staff members.

Dr. Nikhil Gupta was not only the instructor of the class, but also was a valuable resource for the group, especially when the group needed direction and assistance with electrical aspects of their project.

Dr. Louis Cattafesta was ultimately the group's most valuable resource. As the group's assigned faculty advisor, he was there when the group was at a complete standstill with the project. His motivation, knowledge, and guidance placed the group back onto the correct path; without him, the group would not have made the progress that they did.

Dr. Michael Devine not only tasked and sponsored the group with this project, but also helped the group with any entrepreneurial aspect of their project. His entrepreneurial advice enlightened 4 mechanical engineering students without any formal business-related background business.

The employees at both 3D-printing companies also played a huge role in the progression of the project. Without their service, the group would not have any physical parts to display and analyze for their project.

And finally, the remaining C.O.E. staff members also played a vital role towards the group's success. When there was a small question to ask any of them, they were always helpful toward the group.

## ABSTRACT

The work done in this project was aimed at creating repeatable and measurable design improvements to a centrifugal type hairdryer. This is where the air is ejected perpendicular to the intake. This specific hair dryer used was a Bio Ionic Whisper Light and is rated as one of the quietest hair dryers on the market. Its baseline noise measurement was measured at 73.1 dBA. After extensive measurements of the device and through isolating certain components, it was determined that fan speed and the intake baffles are the two key factors in controlling the noise of the hairdryer. Our team aimed to improve the fan system to allow for motor speed reductions and also redesign of the intake baffles to increase the noise suppression on the motor. The redesigned fans were prototyped using a selective laser sintering method of 3D printing, this produces tight tolerances and an almost replicated product. When the fan was tested in the hair dryer it experienced large vibrations due to an unbalance of the center of mass and this thwarted any attempt to test the noise output from the fan design changes. The imbalance was attempted to be removed by using a prop balancer to balance the center of mass on the printed fan. As for the intake baffle they were designed to change the intake of the hairdryer from the side to the back. It also provided extra sound suppression to the fan and reduced the noise at the side of the fan by 2 dBA and reduced the noise in the front by 1 dBA.





# 1. Introduction

Hairdryers are commonly found throughout the world, most notably in one's own household bathroom. Their popularity and development has grown over the 20<sup>th</sup> century due to the inherent nature of its main function: which is to dry hair! Since its birth, several additional features had been applied to thousands of the hairdryer designs, such as variable speed switches, cold-air buttons and even nozzle attachments for styling. One less common feature that can't be found in the majority of hair dryers is a function which reduces the noise output of hairdryers.

The operation of any hair dryer is synonymous with loud noise. There is an increasing demand for hairdryers to have built-in sound-reducing capability, however, the unfortunate tradeoff for such a function is cost; multiple added features' drives the overall cost of an albeit simple device from \$20, upwards to about \$250 for a premium hairdryer with seemingly endless amount of functions. However, these so-called premium hairdryer's focal point usually resides about enhancing the overall appearance a person has after use, and not about their ability to hear after drying their own hair. This rising problem is something this group has decided to tackle; by applying multiple engineering techniques, the group had attempted to develop attachable components which alleviates some of the noise associated with hairdryer-use.

## 1.1 Project Scope

The scope of the project was to design a quieter hair dryer. This is being achieved by making repeatable and measurable noise reduction improvements through design modifications to a centrifugal type intake hairdryer while maintaining its performance. Instead of developing a brand-new hairdryer with its own innovative sound-reducing functions, the group focused their attention on modifying a hairdryer that was deemed to be quieter than the majority of hairdryers in the market. To accomplish this the noise sources have to be determined then design improvements must be thought of and fabricated. These must then be measured to determine their effectiveness.

## 1.2 Standard Components of a Hairdryer

In order to fully explain the intricate contents of this report, one must first understand the basic components of a hairdryer, which can be seen ahead (Figure 1).

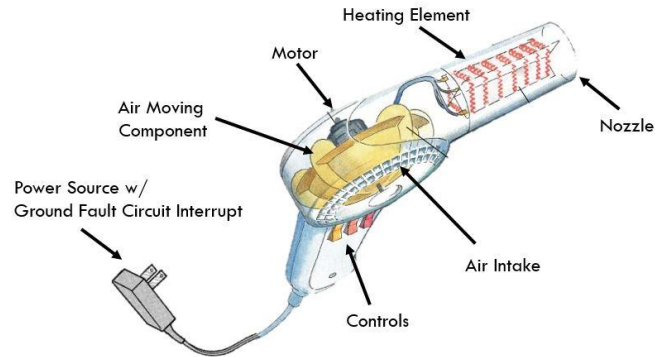

Figure 1: Standard components of a hairdryer

A typical hairdryer contains a power source with a built-in ground fault circuit interrupt to not only provide power to the hairdryer, but also to ensure safety of the user in case the hairdryer is immersed within a pool of water. After plugging the hairdryer into an appropriate outlet, the user would operate the controls of the hairdryer in order to turn it on/off, or to use its built-in variable speed/heat functions. Once the hairdryer's ON-switch is activated, its motor rotates an air-moving component (or fan blade system) about its axis at high speeds. This allows for the entrainment, or suction of air through the intake/s of the hairdryer. As the air is being pulled-in, it is also being directed about the main housing of the hairdryer, which reaches the entry point of the nozzle's shaft. Packets of air travel through the shaft and flows over the heating element, which ultimately exits the end of the nozzle as heated air (or cooled air, depending if the COOL-switch is activated).

### 1.2.1 Background Research

As mentioned before, there are multiple variations of hairdryers that exist throughout the world. The majority of the cheaper models are not designed to be quiet, as their sole purpose is to dry hair. These particular brands move air by use of an axial-fan; this style, or type of fan resembles propellers on a boat or even a ceiling fan; an image of this can be seen ahead (Figure 2) [1].

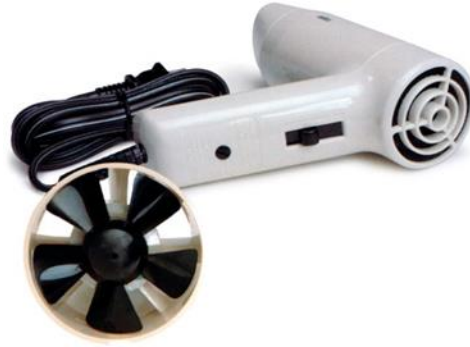

Figure 2: Image of axial fan of a simple hairdryer

These type of hairdryers, equipped with axial fans, pull in air through its rear intake. The general direction of the overall airflow moves straight through the main shaft of the hairdryer. These hairdryers operate at very high speeds and can produce sound power levels up to 100 decibels at low center frequencies [2].

More expensive models which include multiple functions, such as noise reduction features, move air via a centrifugal housing and a particular centrifugal fan blade system; an image of the inner-workings of a centrifugal hairdryer can be seen ahead (Figure 3).



Figure 3: Inside of centrifugal-type hairdryer

The general direction of the overall airflow moves around the center plane of the hairdryer, then through the shaft of the nozzle. Depending on the particular set of fan blade systems used within this type of hairdryer, is a provision of a reduced overall sound power and pressure level output, ultimately making it a more viable hairdryer selection for a noise-reduced product.

## 1.3 Needs Statement

Currently a majority of the hair dryers on the market are too loud, to the point where they are close to the level at which noise induced hearing loss. They also create disturbances in both homes and salons. Designing a quieter hairdryer would fill a niche in the market for users that want to dry their hair in a peaceful setting.

## 1.4 Constraints

The group's added noise-reducing components applied to a pre-existing hairdryer need to reduce its sound pressure level without losing more than 10% of its overall volumetric flow rate. The group also must create lightweight parts that, when attached to the original device, do not exceed a total hairdryer-weight of 1.5 pounds. Another restriction to redesigning a new fan blade system, is that it shall not exceed the original fan's dimensional properties; the main reason for this is mainly due to the boundaries of the hairdryer's original centrifugal housing because that will not be reshaped. One final constraint is to ensure the created components do not compromise the safety of the user.

## 2. Experimentation

### 2.1 Observed “Quiet” Models

Many hair dryers were reverse-engineered at the beginning of this project. Used hair dryers were purchased in bulk from a local thrift store and disassembled to better understand the inner-workings of the devices. As mentioned before, the two main types of fan systems are axial and centrifugal. The axial fan ejects air parallel to the axis of rotation while the centrifugal ejects air perpendicular to its axis of rotation. It was audibly determined that hair dryers that had a centrifugal type air intake system performed quieter. Thus, the group’s next purchases were of centrifugal type hair dryers that were specifically marketed and labeled as quiet dryers; two different quiet brands were bought each with their own unique centrifugal style, which can be seen ahead (Figure 4).



Figure 4: Centrix Q-Zone (Left) and Bio-Ionic Whisper Light (Right)

One of the two hairdryers were the Centrix Q-Zone. It has a dual air intake from the both the tops and bottom of the rear end of the dryer; it also has three heat and speed settings. The Bio-Ionic Whisper Light was the other centrifugal type and had side dual air intakes. These hair dryers were subjected to subsequent tests that measured their performance and sound output.

## 2.2 Performance Testing

One criterion of design modifications is that the performance of the hairdryer was not to be diminished by more than 10% with design changes aimed at suppressing noise. To effectively be able to quantify shifts in the performance as a result design change, the group needed to determine the baseline for comparison; this is a measure that will quantify the heat output of the hairdryer before any modifications are done to it. The performance criteria measures how much heat is being carried by the airflow out of the nozzle; this was carried out by employing Equation 1,

$$\dot{Q} = \dot{m} * C_p * \Delta T \quad \text{Eqn. 1}$$

where  $\dot{Q}$  is a measure of the heat,  $\dot{m}$  is the mass flow rate,  $C_p$  is the specific heat of air, and  $\Delta T$  is the temperature-rise that the hairdryer creates. The specific heat is taken to be constant at  $1 \frac{kJ}{kg K}$  and separate experiments were used to determine the mass flow rate and the rise in temperature.

The mass flow rate is specified as the volumetric flow rate times the density. The density is taken as a constant value for this situation at  $1.225 \frac{kg}{m^3}$ . The volumetric flow rate was calculated by integrating the measured velocity profile, which can be seen ahead in Equation 2.

$$V = \int_0^r v(r) 2 \pi r dr \quad \text{Eqn. 2}$$

To determine the velocity profile, the group used a pitot static tube connected to a digital manometer; this process can be viewed ahead (Figure 5). The Pitot tube measures the stagnation, or total pressure of the flow; this allowed the group to determine the velocity based on the relation in the Bernoulli's Equation (seen ahead in Equation 3),

$$U = \sqrt{\frac{2(P_t - P_s)}{\rho}} \quad \text{Eqn. 3}$$

where it is the square root of the difference between the total pressure and the static pressure times two divided by density.



Figure 5: Pitot tube measuring total pressure of hairdryer jet (left) and an infrared thermometer measuring temperature change of the surface (right)

The Pitot tube was connected to a mechanical traverse that used LabVIEW to operate and translate it up or down in 1, 3, or 5 mm increments. To determine the velocity profile, the group aligned their measurements in the centerline of the nozzle just outside the exit plane, then moving upwards to the outer radius of the nozzle by 1 mm increments; they recorded the pressure at each location. The velocity profile was assumed to be symmetric, and this data was post-processed using MATLAB to generate visual plots.

In another experiment, an infrared temperature was used to measure of temperature of the air leaving the hair dryer. This experiment was set-up by mounting the hairdryers approximately 6 inches away from the table surface; the temperature of the table was allowed to reach steady state prior to documenting measurements. The thermometer's design utilized a laser that showed where the measurement was being taken before displaying temperature reading; the temperature of the table was also measured before heat was applied in order to determine the change in temperature.

## 2.3 Sound Measurements

Reducing the noise produced by the purchased hairdryers is the main goal of this project. Thus, a set method has to be created to determine and quantify the noise produced by the hairdryers for



comparison to the later design changes. The groups' tests were performed in an anechoic chamber (Figure 6); this special facility greatly reduces the reflection of noise.



Figure 6: Sound-testing setup in the anechoic chamber

This aided the validity of the group's measurements as they were not influenced by the variable surroundings in an uncontrolled environment. To measure the noise signal, a  $\frac{1}{4}$  inch free-field microphone was used and mounted onto a tripod. This was positioned at multiple locations radially around the hair dryer and in different planes; this allowed the group to see the loudest spots around the hairdryers. The hair dryers were held in place using a guitar stand so that it was balanced and at a projected level; duct tape was also used as a connection to the guitar stand. The overall reason for this process was not only to keep the hairdryer secure and level, but also to reduce any resulting vibrations that may have come about between the two surfaces.

The pressure fluctuations seen by the microphone was measured in a voltage with a specified sensitivity associated with the microphone. A computer and LabVIEW program were also used to record data with a sampling frequency of 65,536 Hz, which was averaged over 30 seconds. The sound was recorded at a distance from the hairdryers that a general user would see during actual usage; this distance was approximately taken at 6 inches. For measurements in the front and back

of the hairdryers, it was respectively 6 inches from the center of the nozzle and 6 inches from the center of the intake surface.

Justification for the initial sound testing was to determine the baseline noise level of the hair dryer; means were taken to setup instances where specific noise sources could be tested, such as geometric components and settings for speed of the dryer. The idea was to isolate one component individually in order to determine effect on overall noise level. This aim was to determine the greatest contributor to the noise because improving that component would lead to greater noise reduction. Both hairdryers were tested on different speed settings in order to isolate fan speed as a factor to noise production; they were also tested with the intake baffles removed. This altered the level of suppression on the fan and showed how effective they worked. For the Bio-Ionic Whisper Light, the heating element that is housed in the nozzle was removed to determine its contribution to noise. This was done by cutting a hole in the base of the nozzle as a way to close the housing back up when it was pulled through the bottom. The complexity of the circuits in hair dryers did not allow for removal of the heating element completely. Both the removal of the heating element and intake baffles can be seen ahead (Figure 7).



Figure 7: Heating element removed (left) and intake baffle removed (right)

### 3. Results of Observed Models

#### 3.1 Comparing Performance Results

The performance for both of the hairdryers were measured and calculated for low and high fan speeds. They each produced roughly equivalent heat output rates on both high and low speed settings, which can be view in the table below (Table 1). The Centrix Q-Zone had a higher volume flow rate while having a lower measured temperature. The Whisper Light got its heat output primarily its temperature as its volume flow rate was lower than the Centrix; these measurements will be useful in comparing to post modification performance.

Table 1: Comparing performance of Centrix Q-Zone and Whisper Light

	Centrix Q-Zone		Whisper Light	
Speed Setting	High	Low	High	Low
Quoted Power Rating	1500 W		1400 W	
Temperature 6 in. from nozzle	55° C 131° F	41° C 106° F	65° C 150° F	50° C 122° F
Volume Flow Rate	0.0284 $\frac{m^3}{s}$ 60 cfm	0.0201 $\frac{m^3}{s}$ 39 cfm	0.0226 $\frac{m^3}{s}$ 50 cfm	0.0142 $\frac{m^3}{s}$ 30 cfm
Motor RPM	514	360	730	520
Heating Rate ( $\dot{Q}$ )	<b>1190 W</b>	<b>495 W</b>	<b>1227W</b>	<b>508 W</b>

The velocity profile was determined from Pitot tube measurements; it was taken from the centerline to the outer radius, and assumed to be uniform in the circumferential direction, which can be seen ahead (Figure 8). Due to the heating element in the nozzle, the profile did not resemble that of a regular pipe flow. Instead, it had a jagged top-hat style which was due to the losses seen by the heating element impeding the flow. By viewing the comparative plots below, both the Centrix Q-Zone and the Whisper Light had roughly the same maximum velocity of  $22 \frac{m}{s}$ , which occurred closer to the outer radius than the centerline; this was a direct cause of the heating element being positioned down the center. The average velocity for both hairdryers on high speed was  $18.5 \frac{m}{s}$  and took into account the greater contribution further away from the centerline. The next

plot shows an overlay of the velocity profiles for the Centrix on high and low speeds; the low speed setting reduced the average velocity to  $13.1 \frac{m}{s}$ .

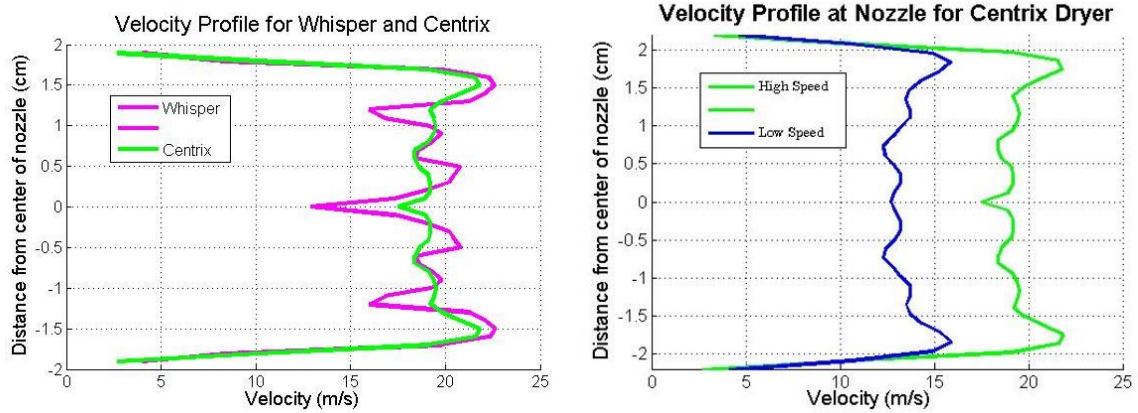

Figure 8: Velocity profiles of Centrix and Whisper on high speed (left) and velocity profiles of just the Centrix on both high and low speeds (right)

### 3.2 Noise Analysis Overview

Measuring noise and comprehending the results was a pivotal aspect of this project. It was something that would guide the group, as well as provide the group with conclusions toward the design future work. Noting that sound is just pressure fluctuations in the air, the group measured this using a microphone that recorded a voltage signal for the observed sound. The measurements for the project were taken in the anechoic chamber at the A.M.E. facility to minimize reflections of sound from the walls; this allowed for a better representation of measuring the noise generated at the source, which was the hair dryer. The sound data came in as a signal measured at a sampling frequency of 65,536 Hz. This signal was then broken down into distinct frequencies and their magnitudes were obtained using a Fast Fourier Transform (FFT) code in MATLAB. It showed the contribution of each frequency that made up a portion of the measured noise. This was shown in a spectrum of frequencies seen ahead (Figure 9).

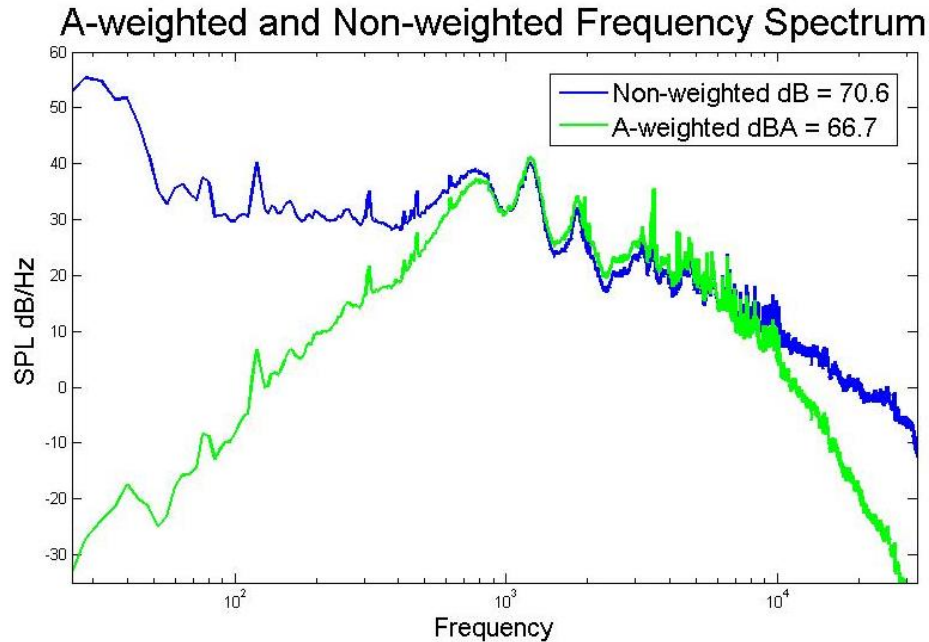

Figure 9: Frequency spectrum with an applied A-weighting filter (colored in green)

A main result the group determined from this spectrum was the *sound pressure level* (SPL); this is an indicative value of how loud the signal that one measures. The unit of measure for the SPL is a *decibel*, which is a logarithmic ratio of the measured pressure over a reference pressure (generally 20  $\mu$ Pa). The spectrum above the SPL was calculated by integrating underneath the curve. Noting that human-hearing is less sensitive at lower and higher frequencies while being most sensitive between 1-2 kHz, a filter was applied to the signal in order to dampen the lower and higher frequencies, while slightly amplifying the more sensitive ones (which approximately range from 1 kHz to 6 kHz). This filter can be seen above, where the blue curve is the unfiltered signal decomposed into frequency, and the green curve is the one with the A-filter applied. A major design goal was to push the sound to lower frequencies in order to take advantage of the A-weighted filter as it would reduce the perceived noise.

Sound measurements are very dependent upon the distance of the microphone away from the source, and the setting it is measured in. In a free-field setting, the measured SPL is decreased 6 decibels for every doubling of the distance, and the surroundings of the noise source changes the sound field. Comparing two different sound measurements require that the set-ups be the same in order to confidently compare them.

For fan systems, a key frequency that occurs in the spectrum is the *blade pass frequency*. This is a frequency that results due to the speed that the fan is spinning and the number of blades on the fan. It can be thought of as the number of times a fan blade passes the closest part of the housing per second. The part where the fan blade comes closest to the housing is generally the *volute tongue*; this is the part where the nozzle connects to the fan housing and is where a majority of the noise is generated, as it has the greatest impulse from the imparting-air off of the blades. Knowing this frequency from the measured spectrum, ultimately allowed the group to determine the angular velocity (in RPM) of the fan by knowing the number of blades on the fan.

### 3.3 Noise Source Contributions

Determining the contribution to the noise of different components and settings was pivotal to finding the largest source of noise. When aiming to decrease the noise of the system, it was only logical to go after the top one or two noise sources. This was because a reduction to a noise source that did not compare in magnitude to the loudest source would have a negligible effect when it was removed. This was due to the nature of the logarithmic scale of the decibel measurement. The contributions from aspects of the hairdryers must be isolated to determine their contribution. Some of the easy ones to isolate were the fan speed, the intake baffles and how hotter air plays a part in sound generation. The noise source contributions presented ahead are for the Bio-Ionic Whisper Light (Figure 10). The Centrix was not tested with modifications (except for low and high speed) because its design did not allow for easy design manipulations, as any design modification would have compromised its operation. The Whisper, on the other hand, had a much more variable design which allowed for more individual components to be measured.

To give some perspective on how the decibel relates to hearing, it should be known that a 10 dBA increase in noise acts as a doubling of perceived loudness. This was almost reached as significant variation in noise from a single parameter of fan speed. The control the group had over this variable was the speed settings on the hairdryer itself, and when the group transitioned from low to high speed, it resulted in a 40% increase in fan speed for both hairdryers. From that, the group was able to determine the motor speed increase from the frequency spectrum based on the blade passage frequency and the 36 blades on the fan.

Another significant factor in the noise is the baffle-parts placed over the intake of the hair dryer. These acted as a means to suppress noise that originated from the fan. Their removal resulted in an increase of measured noise. The heating element removal was seen to play a very small role in the generation of noise in the hairdryer. The aim of removing it from the flow path was to reduce the turbulence generated, as that is a source of noise. The Whisper also allowed for the complete removal of the fan from the housing, leaving only the motor inside. Removing the fan produced a decrease in SPL, but created a much greater annoyance level. When the fan was not present, the spectrum showed a much higher frequency noise contribution that was not apparent when the fan was attached. This is because the fan acted as a suppressor to the motor noise, and was a necessary component in the operation of the hairdryer. Removing the fan also removed any air interaction from the noise contributions.

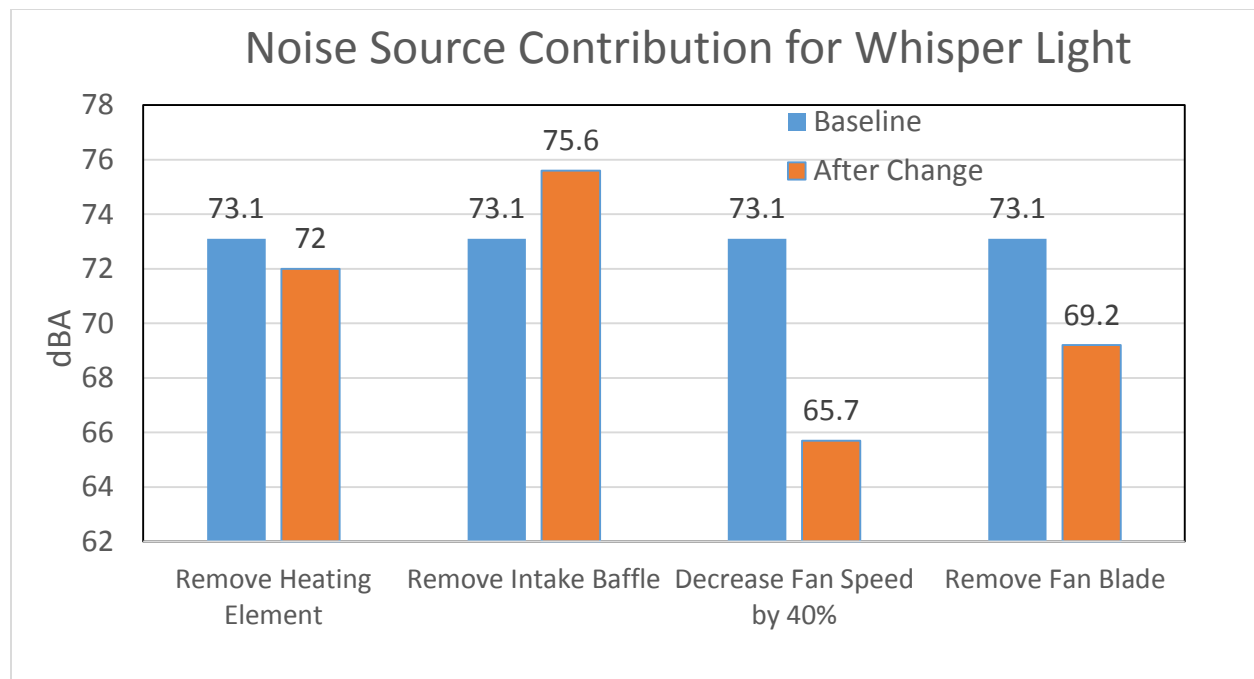

Figure 10: Graph pertaining to noise source contributions for the Whisper

The bar graph above displays the relative contribution of each source from the baseline measurement. The base measurement was taken with all of the components attached, and operating on high speed at a value of 73.1 dBA. These measurements were taken at a location out in front of the hair dryer nozzle, at a point where someone using the dryer would experience the noise. It was determined that after removal of the heating element, there was a 1 dBA drop in the noise produced, due to a decrease in turbulence. The removal of the intake baffles caused a 2.5



dBA increase in measured sound as more noise escaped from the motor. The reduction in fan speed provided the greatest reduction of noise, at a decrease of 8 dBA. The removal of the fan blades reflected a drop in 4 dBA, but completely violated the constraints, as no air flow was produced.

### 3.4 Design-Reasoning for Moving Forward

Moving forward, all modifications and testing would be geared towards the Whisper Light. This was due to the more simplistic design, and also due to it being slightly louder, which ultimately offered more room for improvements. The conclusions that the group drew from these measurements were important in being able to effectively target the greatest noise sources, and to create effective design changes. The group could see that removing the heating element resulted in minimal noise reduction and did not need to be a focus of redesign. These results show that the intake baffles created more noise when they were removed, meaning they were necessary to the design. The group will seek to improve them through a redesign process that will allow for increased noise suppression, while minimizing the loss of flow rate.

It was also known that the largest reduction of noise was due to a decrease in fan speed, thus a conclusion drawn from that was that improvements to the fan system which lead to improved flow rates would allow for a decrease in the motor speed, ultimately producing equivalent flow rate. The Whisper Light dryer is optimal for these improvements. This was because the fan was attached with a nut locking it into place, allowing for easy removal (Figure 11). Having this easy attachment gave the team an opportunity to make changes to the fan, eventually leading to increased performance; these changes will be discussed in the next section.

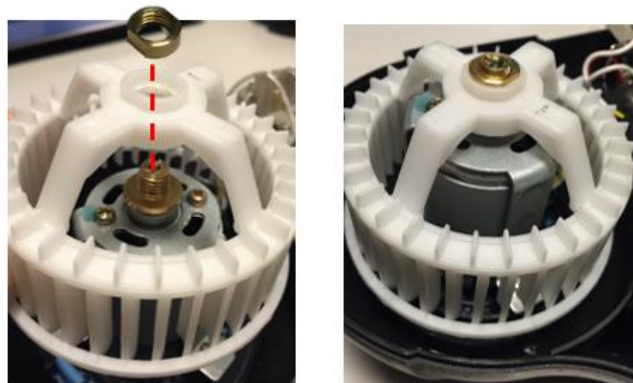

Figure 11: Whisper Light fan mounting, before and after



## 4. Design Modifications

### 4.1 Implementing Test Data into Design Modifications

This project required designs that would ultimately reduce the amount of sound produced by the hair dryer system, without effecting its performance. From the acquired performance data of both the Whisper and Centrix, it was determined that the main sound production was due to the centrifugal fan blade system and intake covers. Thus, the design subsequent design modifications were directed towards the intake covers and centrifugal fan blade system, while taking into account for weight and size. The designs we created that sought to improve the sound produced by the hair dryer include a chevron nozzle, 3D printed redesigned centrifugal fans, and baffles for the intake.

### 4.2 Design of Components for Modifications

#### 4.2.1 Chevron Nozzle

The first design was a chevron nozzle that aimed to reduce the jet noise produced at the exit of the nozzle. Chevrons are primarily used on jet engines that produce subsonic flows in which the chevron induces early mixing of the flow in order to weaken the large scale vortices that are created when the jet interacts with the quiescent air outside of the nozzle. The expelled air from a nozzle can be seen mixing with the free-flow air via chevron in the figure ahead (Figure 12).

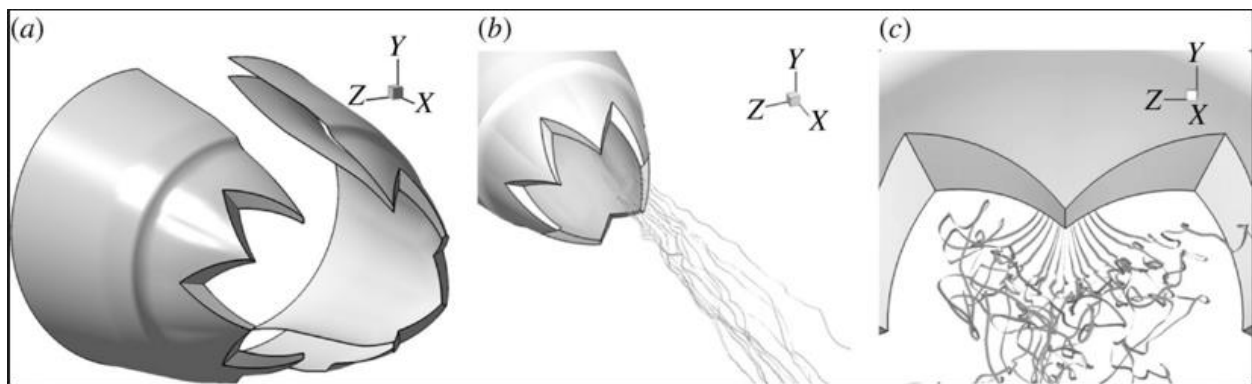

Figure 12: Chevron shows early mixing of outgoing fluid

Chevrons are seen to reduce the SPL 50 to 70 degrees away from the exit plane. This design modification was intended to reduce the SPL out from the nozzle of the hair dryer, where the user

of the hair dryer would be. The application of the chevron nozzle attached to the Whisper can be seen ahead, along with the chevron nozzle tip unattached (Figure's 13 & 14). The entire nozzle was 3D-printed as one piece, and does not add significant weight to the hair dryer itself. The part is only 10 grams and fits snug around the nozzle. It was very cheap to produce as a 3D printed prototype and would be even cheaper if it were mass produced.



Figure 13: Chevron Nozzle applied to Whisper, before and after



Figure 14: Chevron Nozzle up-close

## 4.2.2 Centrifugal Fan Blade System

The main noise source was determined to be the centrifugal fan blade system and its operation at high speeds, so empirical design modifications were made that component. Various design changes were discussed to both increase the flow performance and to reduce the resulting noise from the fan. The way the housing is designed offers extra room for increases to certain areas of the fan and the mount allows for easy removal and mounting of new designs. The original fan blade was a 36 blade squirrel-cage fan design and can be seen below, and the circle connected to the four legs is where it is mounted with the screw (Figure 15). The subsequent empirical design changes are meant to manipulate the fan in a manner that allows for easy understanding of what changed the results.



Figure 15: Original Fan recreated in SolidWorks

The process that the group initially tested to create these prototypes was meant to function in the hair dryer is a type of 3D printing called FDM, where a nozzle ejecting plastic traverses a XYZ grid to create the part layer by layer. It produced subpar results as the tolerances are not to the standard needed for high speed fans. The next method the group looked into was selective laser sintering (SLS); this is a type of 3D printing that spliced the CAD model into horizontal layers 0.1 mm thick, then uses a laser to melt nylon plastic in a layer by layer manner to build the part up. The powder layer is replaced after each laser application. This method was costlier, but was the more reliable means of prototyping that our product needed. The process can be seen in the picture diagram below (Figure 16).

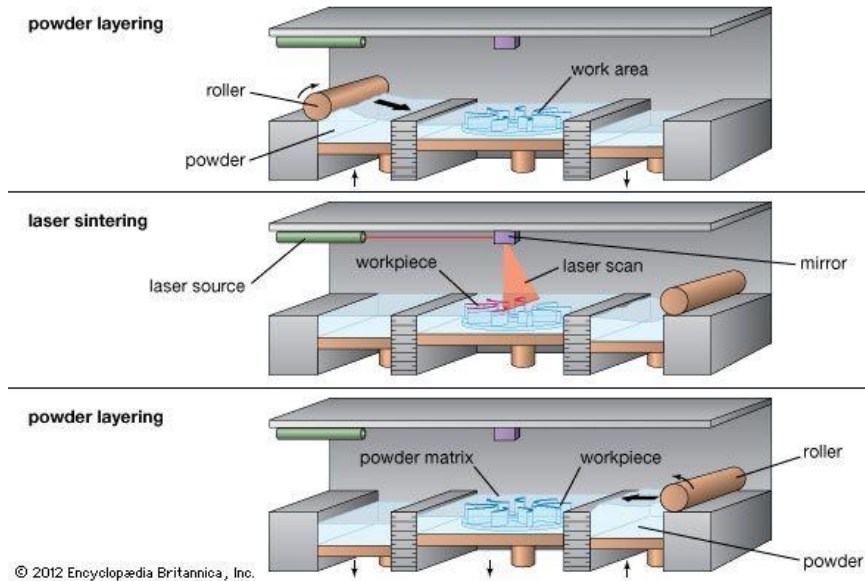

Figure 16: SLS 3D printing process

The first design change that the group wanted to implement was the reduction of the number of blades on the fan. Because fan noise is such a large contributor of the spectrum and the number of fan blades is directly proportional to the blade passage frequency, reducing the number of blades on the fan would reduce the BPF and bring the sound to lower frequencies. This was an easy modification to design, and the goal would be to determine the optimal number of blades. Another aspect of reducing the number of blades was to change it to a lesser number that is also a prime number. This would remove the periodicity seen in the frequency spectrum and spread the sound over multiple frequencies instead of a single tone at the BPF. This alleviates the annoyance factor of the fan that is seen as a humming effect that comes with the periodic nature. Also, varying the blade spacing in a sinusoidal manner, where it would bounce between 9 and 11 degrees instead of the constant 10 degrees, is a result of the 36 blades. This would also effect the tones created in the spectrum.

Having less blades on the system would most definitely lead to a reduced amount of flow generated. This lead to the idea of increasing the surface area of the blades for both the original and the reduced number of blades. The current fan model had roughly 1 cm clearance on each side where the height of the fan could be increased. This was something that the group believed would increase the flow rate. Another geometric design change was to reduce the outer diameter of the fan to lessen its interaction with the tongue of the housing; this is where a majority of the

fan noise is created. The last modification that was planned was to add trailing edge saw-tooth serrations with the intention of breaking up the air leaving the blade sooner and reducing the impulse of the air as it interacts with the housing.

Due to the team's inexperience and unfamiliarity with the quality of the products produced from the SLS printing machine, they limited the first run of parts to two fans. The first was an exact replica of the original that was drawn in SolidWorks. This creation of this fan was to compare its results to that of the original to ensure these products produced a similar behavior to the original. If it performed similarly, the group could consider the prototype effective and be confident with the comparisons between SLS printed fans. The other fan printed was a 29 blade replica fan to compare with the 36 fan blade printed fan. These fans can be seen ahead (Figure 17).

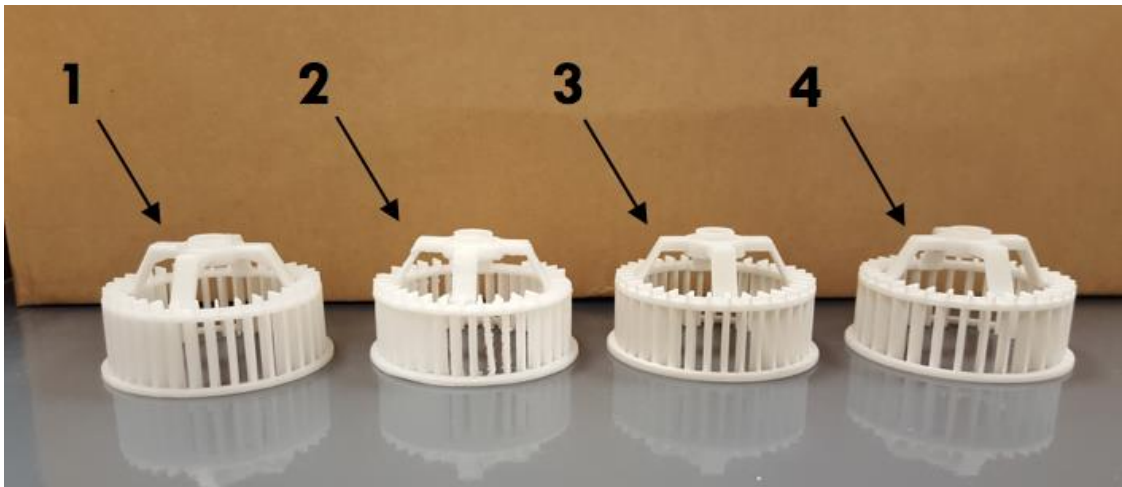

Figure 17: 3D-Printed Centrifugal Fan Blades (1: Original Blade, 2: FDM 3D-printed of original, 3: SLS 3D-printed of Original, 4: SLS 3D-printed with reduced number of blades)

### 4.2.3 Intake Baffles

One way to reduce intake noise was by redirecting the incoming air using intake baffles that pull air from the back. With most any baffle, there will a performance drop associated with this attachment, coming in a reduced volume flow rate. Even with this performance drop, it was a necessary design aspect, that if designed effectively, would yield a balance between intake noise and performance. The intake baffle designs were created with the goal in mind to direct the sound towards the rear of the hair dryer away from the user. They also act as a means to suppress the noise that escapes from the fan housing, where a majority of the noise was created. There were a total of three baffle designs created. All with the same general shape, but with varying intake area

and geometric patterns at these intakes. The figure below displays the baffle design where the inner intake connects to the housing of the hair dryer (Figure 18). The air was initially pulled into the outer intake, into the body of the baffle, then brought into the housing through the inner intake.

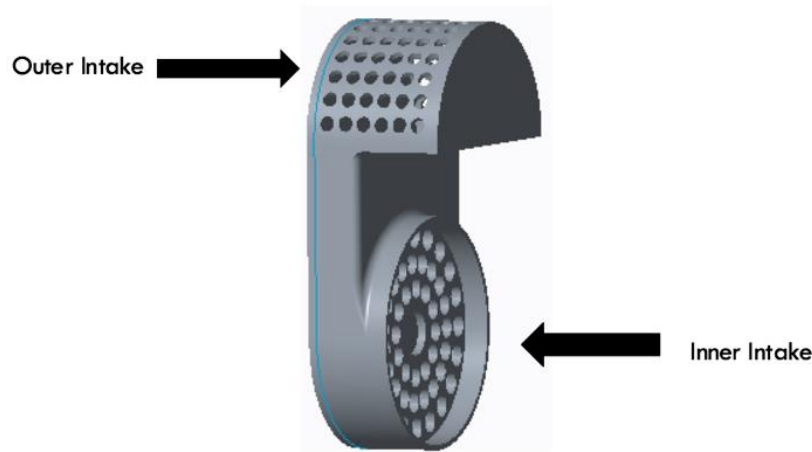

Figure 18: Angled view of Intake baffles

Each pair of baffle designs was made in pairs to fit on both sides of the Bio-Ionics's intakes and they would replace the original blue intake covers. The design primarily reduced sound by causing the intake noise to not only be directed away from the intake, but also take a 90° turn inwards. The two sets of intakes (both inner and outer) also promoted lower sound production by reducing the volume intake to lower volume. This did not mean that the hair dryer was obtaining any less of air volume; it was acting as a funnel that inquired the same amount of volume-in, but the outer intake did not produce a large sucking-noise. This was because the inner intake-area is smaller than the outer intake-area.

Each intake baffle weighed 36.7 grams, which was seen as a negligible weight addition and did not add enough weight to be out of the set constraints for the project. The figure below shows each baffle design, and as one may notice the inner intakes are different (Figure 19). Information on each baffle design may also be seen in the table below (Table 2). Two of the three designs have large outer intake areas than the inner; this was done in order to determine which design would be better at reducing the SPL level.



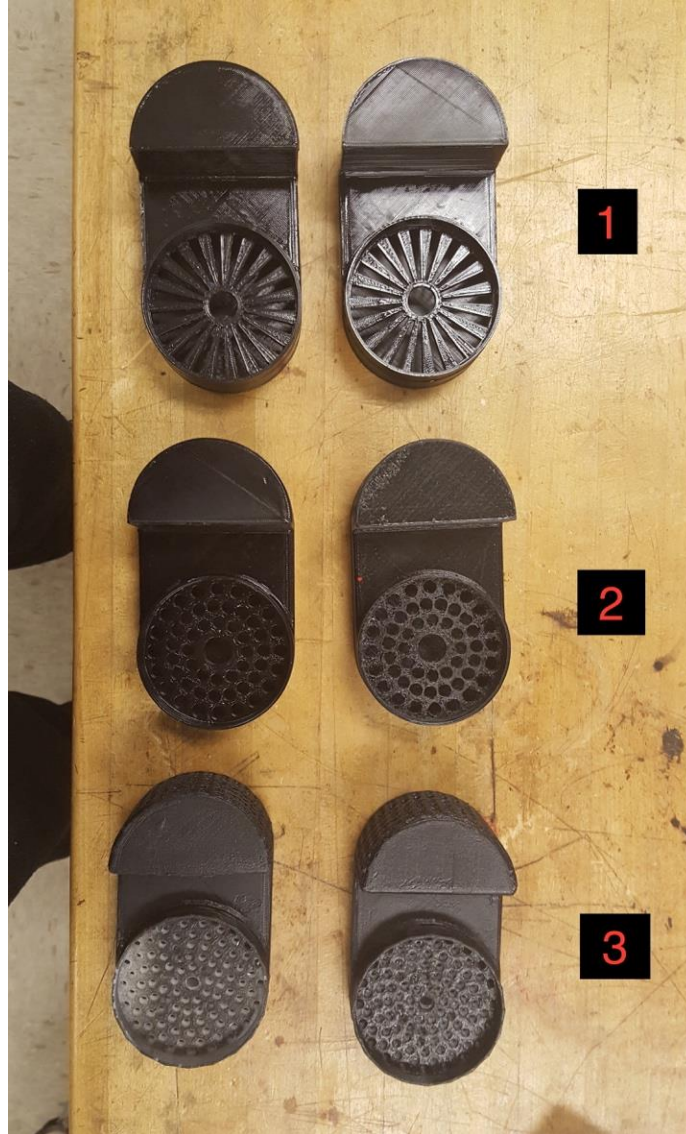

Figure 19: 3D-print Intake baffle designs

Table 2: Baffle Design Specifications

Baffle Design	Inner Intake Hole Shape	Outer Intake Hole Shape	Inner Intake Area (in <sup>2</sup> )	Outer Intake Area (in <sup>2</sup> )	Channel Intake Area (in <sup>2</sup> )	Weight of Each (grams)
1	Triangular	Circular	2.49	1.9	1.2	35.7
2	Circular	Circular	2.55	1.9	1.2	38.2
3	Circular	Circular	1.008	1.28	1.2	36.7

## 4.3 Results and Testing of Design Modifications

All tests for noise were completed in the AME buildings anechoic chamber and the tests for performance were completed in the thermal fluids lab at the college of engineering. The following sections give the results of the testing of the design modifications and attachments.

### 4.3.1 Chevron Nozzle Tip

Tests were conducted with the chevron was done in the anechoic chamber where it was attached to the front of the nozzle to analyze the variations in noise. The results with it on are compared to the baseline measurements with nothing changed. The measured SPL difference between the two cases was nonexistent, as they resulted in the same values with and without it. One of the reasons for this is primarily because the flow expelling from the nozzle is not at a high enough velocity to actually be affected by the chevron. The idea of a chevron is that it penetrates the flow rate without blocking it. With only an angle of attack of 12 degrees, where the peak dips into the exit area, it doesn't penetrate the flow rate enough to reduce the SPL. One may think to increase the angle of attack on the chevron, but once again, the idea of a chevron is to slightly penetrate the flow without blocking it; this works very well when the flow is at the upper region of the sub sonic range. The flow rate expelling from a hairdryer is much too slow for the group to see actual results from the chevron.

### 4.3.2 Centrifugal Fan Blade System

The centrifugal fan blades were received from a company named *3DSystems*. They are a 3D printing company with SLS printing machines. When the product was received, it looked exactly the same as the original, with the only difference being the surface finish which was slightly rougher. The initial test to measure how well it replicated the original was to attach it to the hair dryer and test it on the motor. Upon doing this, significant vibrations were observed, which resulted in much greater noise than seen with original. This unbalance was due to the center of mass not being on the axis of rotation, which resulted in a centrifugal force that increased as a function of angular velocity squared. With our motors spinning upwards of 500 rpm, the slightest displacement of the center of mass off of the axis of rotation would cause an intense force. At this point, testing these parts to compare the noise output of small design changes was not feasible, as



the results would be greatly skewed by the vibrations that were not present in the original fan. A method was needed to balance the fans.

There were two methods used to balance the centrifugal fans, and each of them were *static balancing*. The other type is *dynamic balancing*. And although it is a much better way to go about balancing rotating devices, this method requires its own machine, containing a sensor and a computer setup. This is generally how vehicle tires are balanced. Because dynamic balancing seemed unfeasible, the team decided to begin with static balancing.

The main goal of static balancing was to get the center of mass in the geometric center of the fan; this was done by exposing the heavier side of the fan and adding mass until it was balanced. There were two ways utilized in static balancing, the first was done by balancing the center point of the fan on a needle point. When centered correctly, the heavier side of the blade would sag down further than the lighter areas of the centrifugal blade. This method was the cheapest of the selection, being that it was completely free. However, the test ended up being very inaccurate, as it was very difficult to be repeatable. When the part seemed balanced, from this method it still produced strong vibrations. This method may be seen in the figure below (Figure 20).

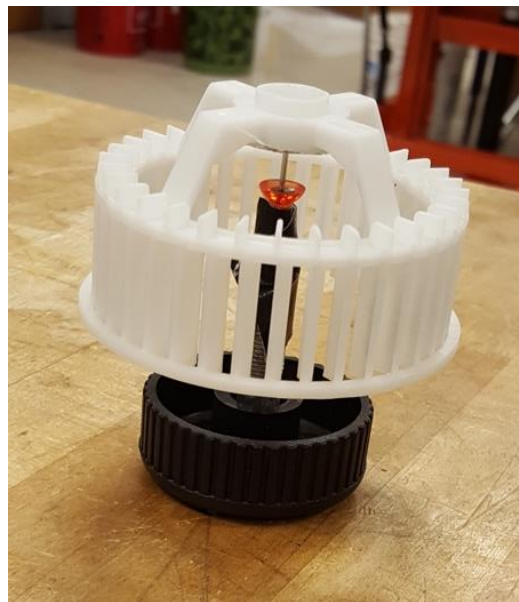

Figure 20: Static balancing on a pin

The second method of static balancing was done by purchasing a prop balancer, which is normally used for balancing R/C aircraft props. A prop balancer utilizes two magnets; they work as frictionless bearings that support a revolving rod. This revolving rod runs through the center axis

of the fan about which it rotates; the heavier side of the fan drops to the bottom. By adding mass to the part of the fan that settles at the top, allowed for the new heavier side to drop to the bottom. This process was repeated until the fan does not have a heavy side. So that when the fan is completely balanced, the fan may be rotated in any position without it counter-balancing and rotating on its own. Hot glue was used as the means to add mass because it could easily be positioned and was easily removable. This method may be seen below (Figure 21).



Figure 21: Static fan balancing on a prop balancer

This static balancing method resulted in much more acceptable performance of the fan after it was deemed balanced. It had reached a point where vibrations were minimal, and testing could be done on the fans. Sound and performance testing is the next step in the process of determining if the fan modifications made improvements.

### 4.3.3 Intake Baffles

There were three different renditions of the baffle design created, with each of them having different inner intakes. These were also tested in the anechoic chamber, with and without the baffles attached. Along with measuring the group's designed baffles on the hairdryer, cases with the factory-made intake covers and no intake covers were tested. There was a distinct audible sensation that could be observed when the new baffles were applied. The perceived noise drop

was confirmed through the sound testing experiment. The sound testing measurements were taken at three different locations radially around the hair dryer in the plane of the nozzle. This is shown in the figure below, and are labeled as 1, 2 and 3 (Figure 22).

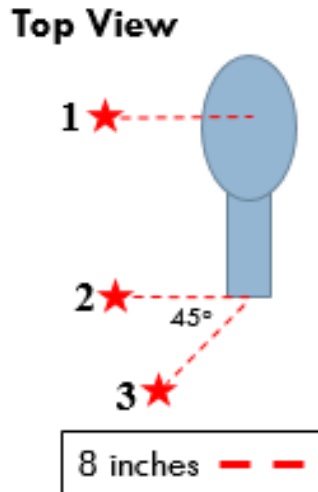

Figure 22: Noise testing location schematic

Location 1 is directly to the side of the hairdryer’s intake (before redirection). Location 2 is directly to the side of the nozzle exit, and location 3 is at a 45-degree angle from the centerline and the nozzle plane. The measurements were taken for each designed baffles, stock baffles and with the baffles; these can be found in the table below (Table 3). The measurements shown are A-weighted, and showed the greatest decrease in noise from the baffles comes at the measurement location 1, with roughly a 2 dBA improvement over the stock baffles. While at location 3 there was a decrease of at least 1 dBA.

Table 3: Baffle Noise measurement, A-weighted

	1	2	3
<i>No Baffle</i>	76.6	75.6	76.2
<i>Stock Baffle</i>	74.1	72.3	75.3
<i>Baffle 1 (Triangles)</i>	72.0	72.8	74.3
<i>Baffle 2 (Large Circles)</i>	72.2	72.5	74.0
<i>Baffle 3 (Small Circles)</i>	72.3	72.9	73.9

## 5. Project Management

### 5.1 Schedule

INSERT HERE

### 5.2 Resources

The group had access to many resources that aided the development of their project. The most valuable resource obtained was the group's faculty advisor, Dr. Cattafesta. His knowledge and guidance was immensely helpful in both the technical and nontechnical aspects of the project. He provided genuine advice and feedback to the group's ideas, and encouraged them to take a step back and not get caught up in the small details of the project; this ultimately helped them to be more productive. He offered ideas to keep the team on track towards the right direction. The group is truly grateful for his assistance.

Because the team's project revolved around sound measurements, it was critical to have a reliable place to test and measure sound. This place was the A.M.E. facility's anechoic chamber. It provided a place to get accurate measurements of the hairdryers, along with modification applied to the Whisper. During the sound performed in the anechoic chamber, items such as a microphone, a computer, data acquisition software, a microphone holder, a microphone connecting wire and a tripod to hold the microphone in testing position were all provided by the facility. For performance testing, the group had access to the thermal fluids lab equipment, and used its Pitot tube to measure the velocity profile from the nozzle. It was pivotal in determining the flow rate of the hairdryers.

The group also utilized a plethora of hairdryers toward the beginning of the project in order to better understand how they work. These were both purchased at thrift shops and online sources. It allowed the team to classify them into their various types, as well as see a large number of ideas to look into implementing. These purchased hairdryers were the foundation of the group's project; unfortunately, the electrical components of the hairdryers were too complicated for the group to effectively work within the short time of this project.

The computational resources used toward the project primarily included CAD software, such as Pro-Engineer and SolidWorks. These were used to model the fan blade systems, intake baffles,

chevron nozzle and the housing of the hairdryers. Within the SolidWorks Flow Simulation package, the group was able to generate flow paths of the hairdryer, which led them to view its motion. Along with these CAD packages, MATLAB was used to process all of the sound and flow data. This was helpful due to its ease of use and ability to move through and to quickly analyze many experimental cases.

### 5.3 Procurement

The budget allotted by Team 6's sponsor was \$1,500. The breakdown of the project's expenditures can be seen below (Figure 23).

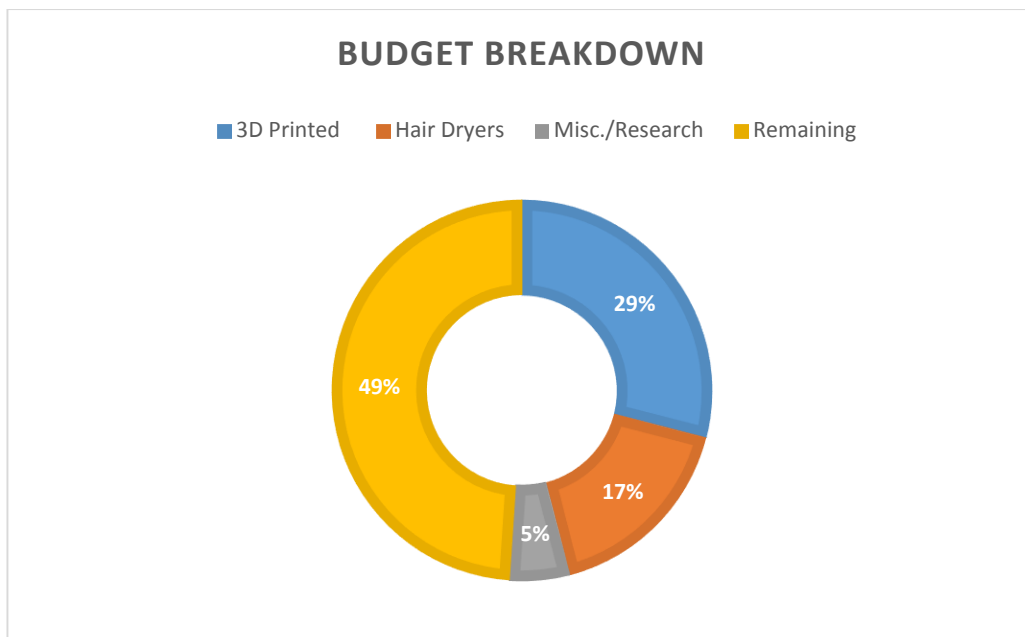

Figure 23: Breakdown of team 6's budget of \$1,500

### 5.4 Communications

Overall communication efforts for this project between group members was primarily conducted through a chat message app called *GroupMe*. It worked very well, and provided an easy method of contact. Emails were used to send documents, reports, CAD parts and research papers between group members. During the first semester, the group struggled with meeting periodically and having a set direction and goals for the project. It showed in the work we produced, as it was not organized or well-formed with all group members. Meeting with our advisors was also something the team struggled with; the blame is in no way placed on the advisor, but mainly due to our

group's negligence. Our struggle was due to a lack of organization and plan for our project, which could have been avoided with periodic meetings with Dr. Cattafesta. At the start of the second semester we set a weekly meeting time with him every Monday at 4 pm. This provided a time where the team could show the work they had done the previous week, as well as discuss what would be best to accomplish for the upcoming week. It was not just limited to that meeting time though, as he made time for the group anytime they had questions. Dr. Devine was also always available and provided keen insight into the entrepreneurial aspect of the project as well as offered ideas about design implementations.

## 6. Conclusion

Our project began with the intent of designing and creating an entire hairdryer, but this was drawn back due to lack of resources and inability to recreate the complex circuitry involved in the hairdryer design. The projects new scope was to design measureable and repeatable noise reduction improvements to the design of a centrifugal type hair dryer. After reverse engineering a plethora of hair dryers, this type of dryer was set on for improvements because it was determined quieter than an axial. The first thing done was determine the greatest sources of noise on the hairdryer during operation then design and implement methods to reduce this noise. The specific hair dryer chosen was the Bio-Ionic Whisper Light because of the ones we examined, it was setup the most advantageously to isolate various noise sources and to subsequently apply design changes. It was determined from acoustic measurements performed in an anechoic chamber that fan speed and baffle design were two key parameters to sound generated by the device. For designs to improve the noise through these two parameters the team looked to implement various changes to the current designs of the intake baffles and fan.

To redesign the intake baffle the team designed and 3D printed them so that they redirected the intake from the sides to the back and suppressed noise generated by the fan. This resulted in a decrease of sound level directly on the sides of the fan as well as out front. The team also decided to create new fans that would aim to improve the flow rate in order to reduce the speed of the fan and maintain the base performance. These changes included reducing the number of blades on the fan, increasing the surface area of the fan blades and adding trailing edge serrations to the blades. To create these design prototypes a method of 3D printing called selective laser sintering was used to create the parts, as this method had the tolerances needed to adequately replicate the original fan. The first print order were of an exact replica of the original and one with 29 instead of 36 blades. The replica would be used to compare its performance with the stock fan to test the validity of SLS printing. The printed fans had an inherent instability where the center of mass was off of the axis of rotation, creating an unbalanced centrifugal force and heavy vibrations. Because of this, no other fan designs were printed and the efforts moved to balancing the fans. The most effective means within our capabilities was a static balancing method that used a hobby air plane propeller balancer. It had a shaft that ran through the center of the fan and attached to magnetic bearings, the heavy side rotated to the bottom and hot glue was added to the top in order to remove any

heavy side of the fan. This method seemed to remove the vibrations associated with the fan and would allow for testing of their noise and performance.

The main recommendation for this project would be to set a goal for the project. By setting a specified goal and desired outcome for this project it would help provide direction to the project. The title of designing a quieter hairdryer leaves a lot of room for interpretation, and lead to the project being a large research project instead of one with a design goal. Our team did work through it and created our own design goals for the project such as an improved baffle and various fan designs. The project is good and has the criteria it needs to be a good senior design project but the way it was presented came off as vague. The combination of research, testing and design provided a complete experience. Designing an entire hairdryer from scratch is something that is too daunting for 4 mechanical students, while setting the goal to be making improvements to a hair dryer, or any appliance for that matter is a more reasonable project with an achievable goal.

With hindsight of this project, many things come to mind as what could have gone better or been done differently. The first, because there was no set goal for the project, would have to be set a definite project goal with constraints earlier. Also taking more initiative in the beginning of the project would have been helpful. We did not perform sound testing on the hair dryer until mid-December, if this is done earlier it would have allowed move forward with the project faster. Another thing is to determine set ways to break up tasks of the project for each person with some overlapping, but the main thing would be to make people responsible for something. Also to weigh the tasks with the amount of time they will take up. For a while in the fall semester our team focused on trying to determine the sound intensity to locate the noise sources of the hair dryer which lead to a dead in and a waste of time.



## References

- [1] <http://www.conceptsnrec.com/Resources/Photo-Gallery/Fans-and-Blowers.aspx>
- [2] [ashraem.confex.com/recording/ashraem/w13/pdf/.../paper10427\\_1.pdf](http://ashraem.confex.com/recording/ashraem/w13/pdf/.../paper10427_1.pdf)

# Appendix A – Gantt Chart Requires Updating

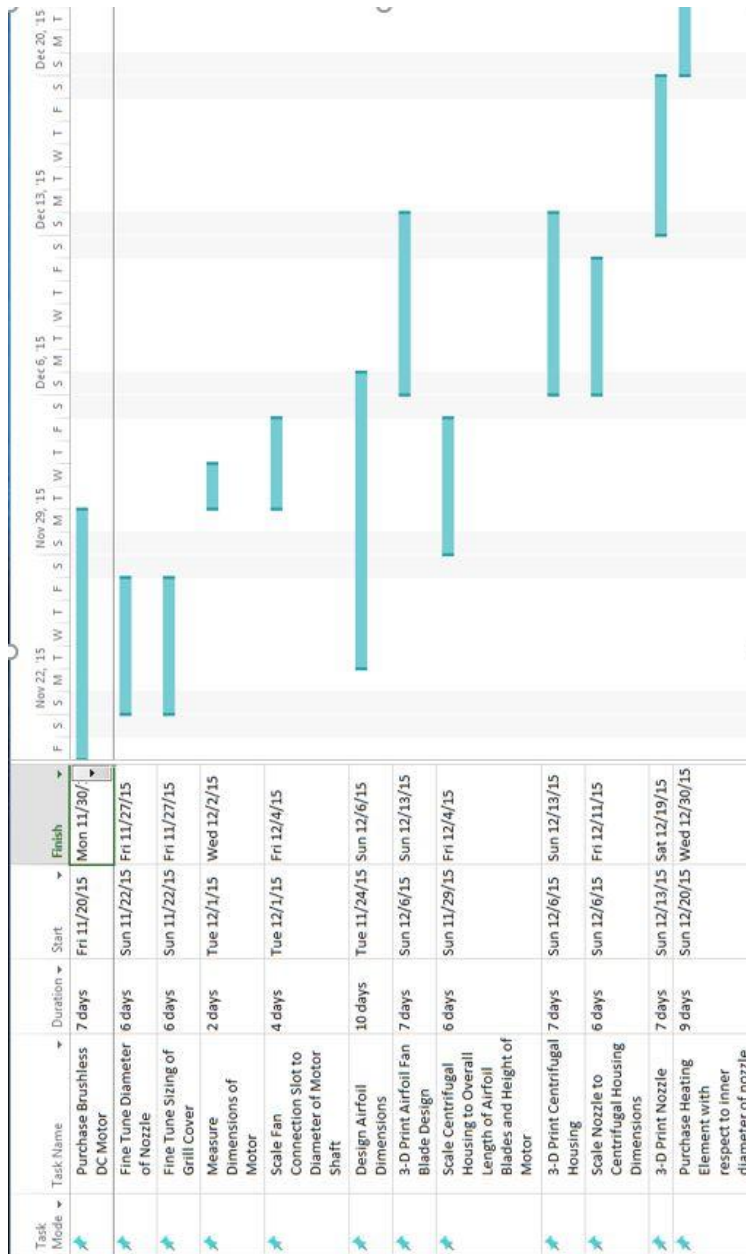

## Appendix B – Exploded View of Assembly

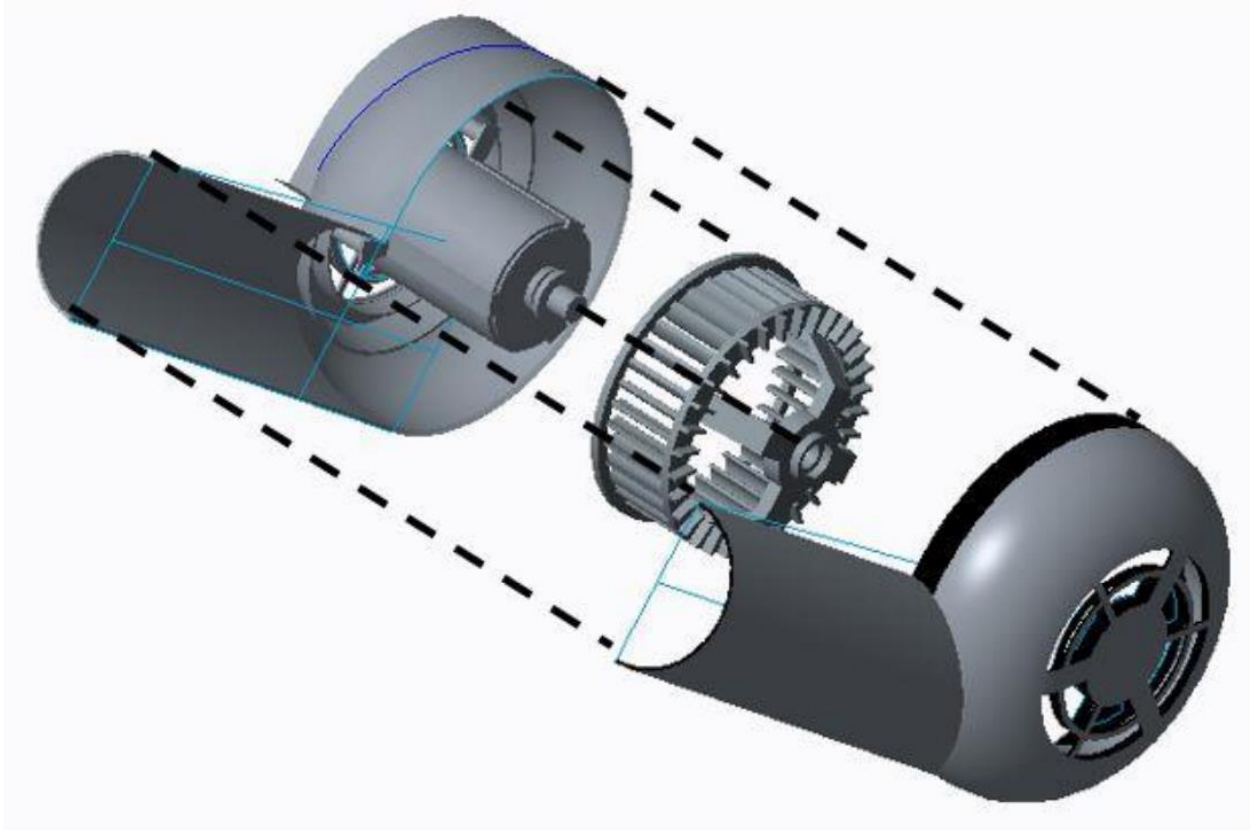

Figure 24: Exploded view of the fan fitted within a basic replica of the Whisper

## Appendix C – Measurements

Table 4: Measurement Values for Specific Parts of the Redesigned Fan Blade System

<b>Aspects of Redesigned Fan Blade System</b>	<b>Measurement Value</b>
Lower Rim Thickness	0.0875"
Lower Rim Diameter	3.0475"
Upper Rim Thickness	0.1025"
Upper Rim Diameter	2.8525"
Inner Mounting Hole Diameter	0.3140"
Depth to Inner Mounting Hole Entry Point	0.1085"
Inner Mounting Hole Depth	0.1185"
Under Mounting Hole Diameter	0.5850"
Under Mounting Hole Depth	0.1215"
Weight	0.7160 oz. (20.3 g)
Quantity of Blades	29
Blade Chord Length	0.2690"
Blade Angle of Attack	> 5°
Blade Thickness	0.0700"
Blade Height	0.9385"
Material	Fiber Filled Nylon

Table 5: Measurement Values for Specific Parts of the Chevron Nozzle

<b>Aspects of Chevron Nozzle</b>	<b>Measurement Value</b>
Weight	0.3668 oz. (10.4 g)
Overall Height	1.2375"
Max Diameter	1.8925"
Inner Base Diameter	0.3225"
Inner Base Depth to Base of Tips	0.5115"
Height from Tip Base to Top of Tip	0.7385"
Tip-to-Tip Spacing	0.8100"
Base Tip-to-Base Tip Spacing	1.0835"
Tip Thickness	0.1725"
Nozzle Base Thickness	0.0875"
Material	ABS
Coating	Acetone Bath
Inward Tip Curvature	≈ 35°

# Appendix D – CAD Drawings

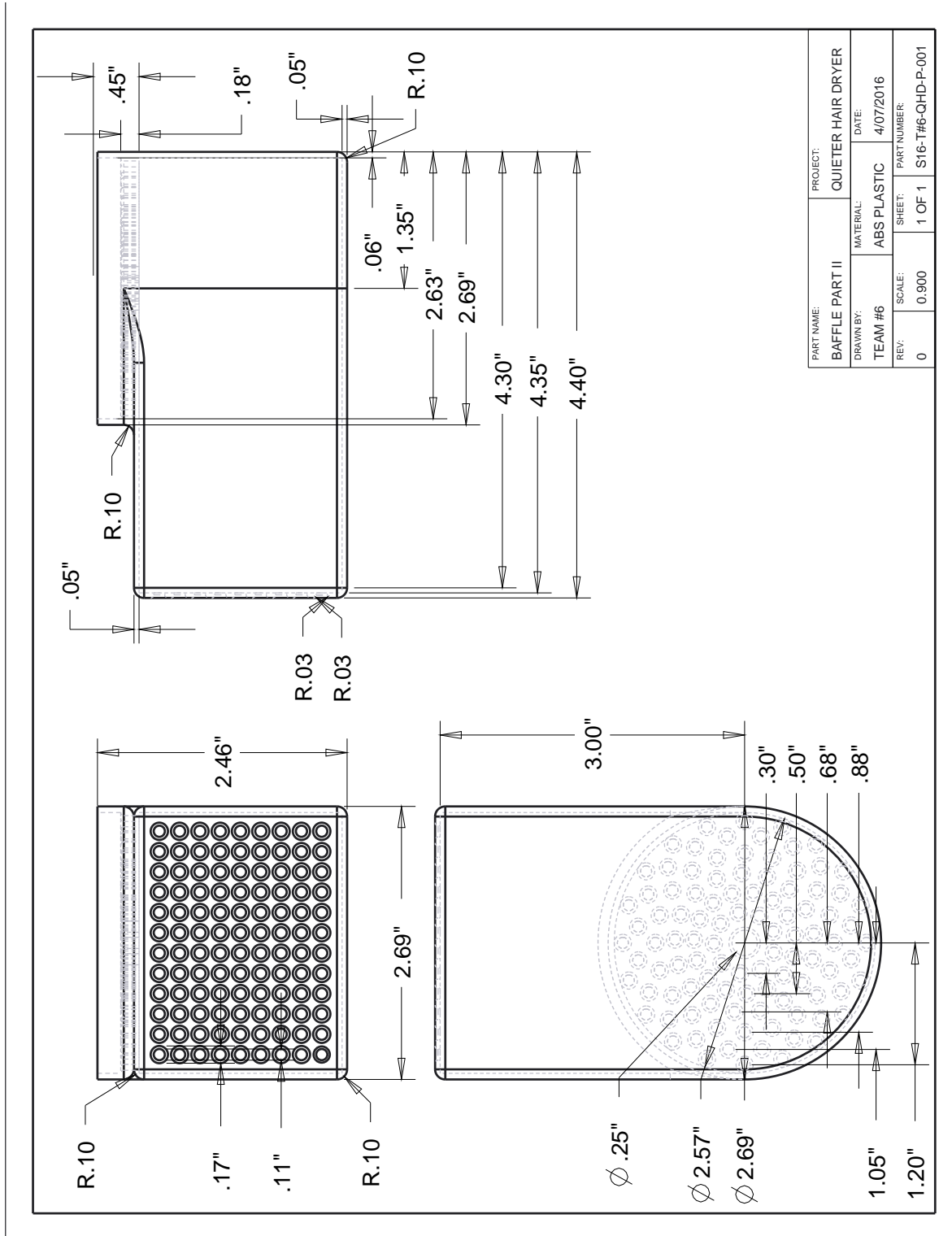

Figure 25: Intake Baffle Part 1

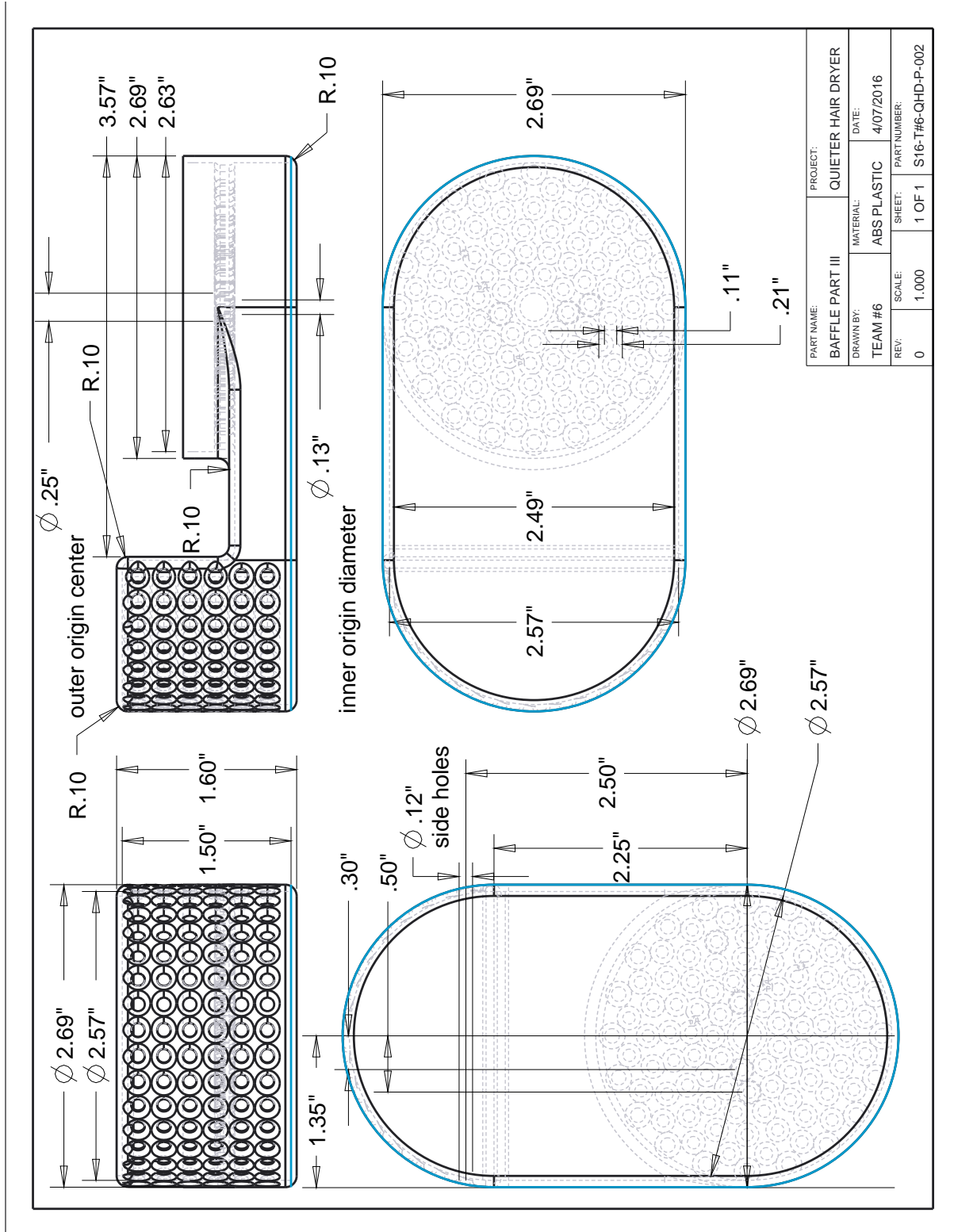

Figure 26: Intake Baffle Part 2

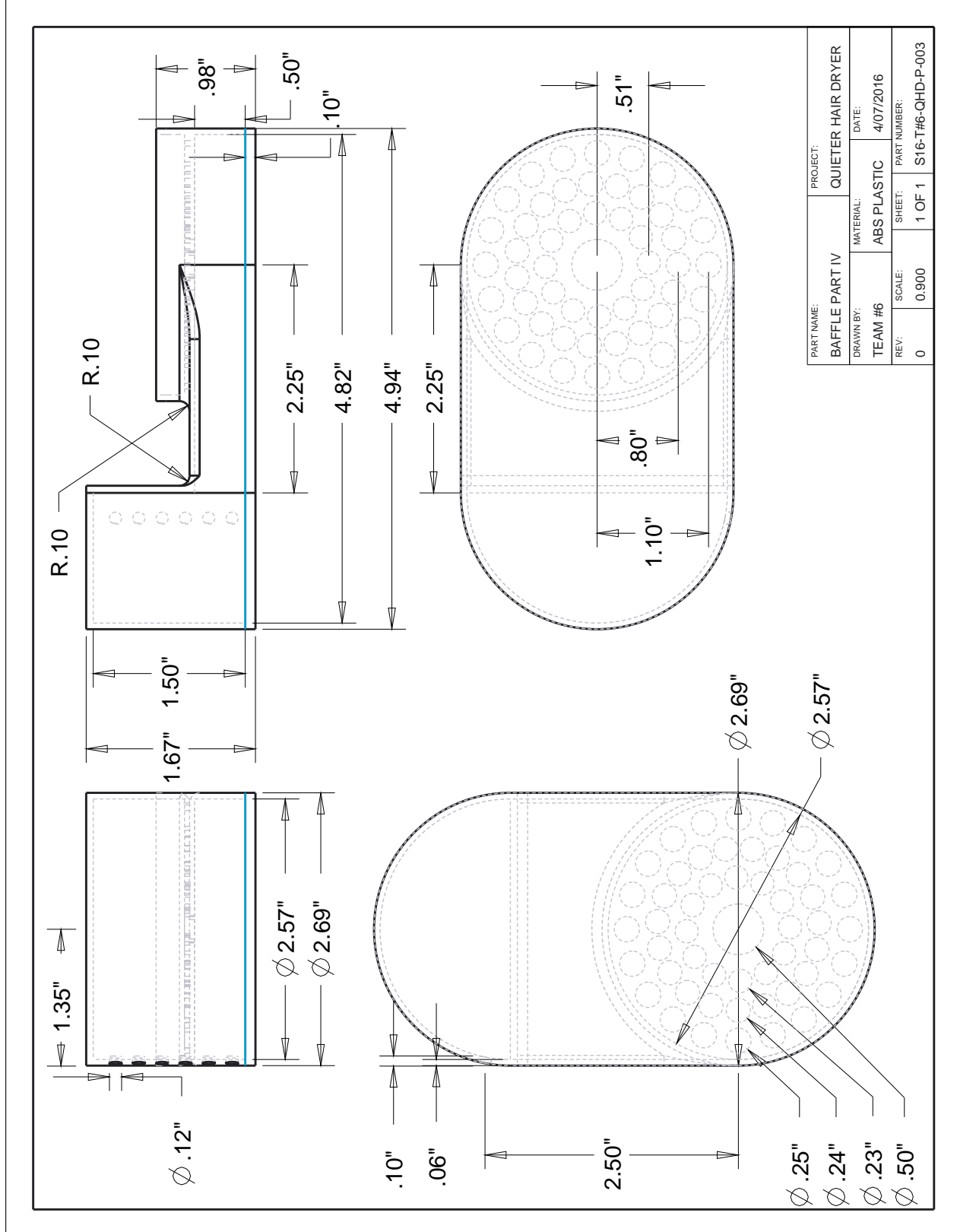

Figure 27: Intake Baffle Part 3



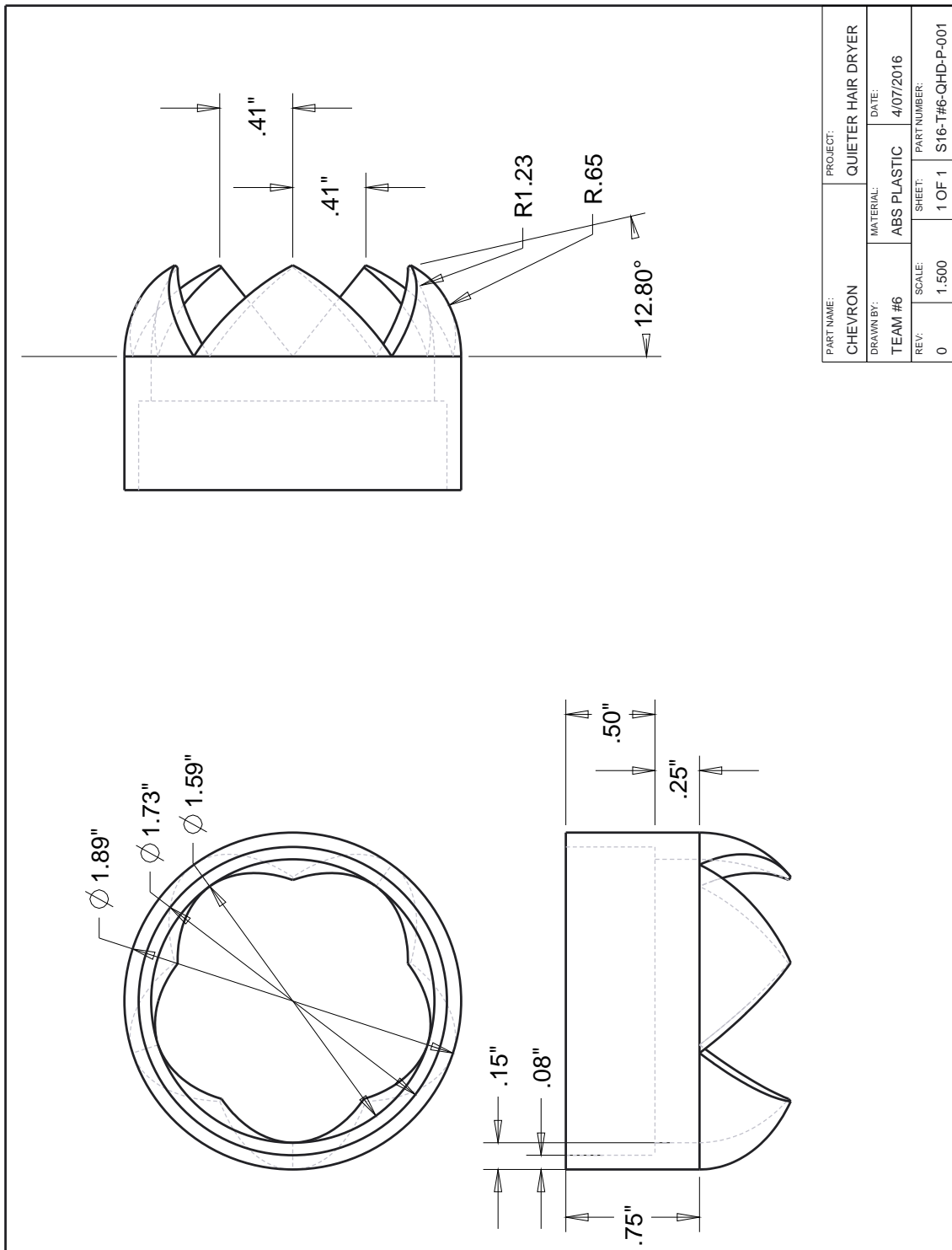

Figure 28: Chevron Nozzle Tip

## Appendix E – Bill of Materials

Table 6: Bill of Materials

Item	Price (\$)	Quantity
Research Paper	25	1
Centrix Q-Zone	80	2
Bio Ionic Whisper Light	80	1
Infrared Thermometer	34.95	1
3D ABS Blade	10	1
SLS Printed Reduce Blade	100	1
SLS Printed Original Copy	100	1
SLS One Day Shipping	65	1
3D ABS Baffle (Triangular)	55	1
3D ABS Baffle (Small Circular intake Holes)	55	1
3D ABS Baffle (Large Circular intake Holes)	55	1
Prop Balancer	20	1

## Biography

Mark is a Senior Mechanical Engineering student from Fort Walton Beach. He served in the US Airforce for 6 years as C-17 Airdrop Instructor Loadmaster and wants to apply the tools learned the military to a future career in Mechanical Engineering. His area of interests include dynamics and wants to start a business in designing and creating new and improved versions of old mechanical designs for entertainment.

Peter is a Senior Mechanical Engineering student from Pensacola, FL. He has interests in the topics of fluid dynamics and renewable energy. He is part of the Florida State University's BS-MS program and also a member of the university's nationally ranked ultimate Frisbee team.

Shawn is a senior in Mechanical Engineering completing his final year. He is from a small town known as Crestview and transferred to FSU in the fall of 2013. He specializes in mechanical work and analysis/simulation. Shawn is a brother of the Phi Delta chapter of Theta Tau. He would like to pursue a career in National Security for a defense contractor. He is also interested in pursuing an MBA after gaining experience in the workforce.

Kiet is from Florida and a senior in Mechanical Engineering. He is interested in the materials field in engineering and also going into research and development for new methods to enhance productivity. He was a FGLSAMP robotic technician under Dr. Collins Adetu in 2013 and worked on constructing robots with various sensors.