

# Project Plans & Product Specifications

## Team 6

### Design of a Less-Deafening Hair Dryer

#### Members:

Shawn Eckert	sme13b@my.fsu.edu
Kiet Ho	kth13c@my.fsu.edu
Mark Johnson	maj12b@my.fsu.edu
Peter Van Brussel	pav11b@my.fsu.edu

#### Faculty Advisor

Dr. Cattafesta

#### Sponsor

Dr. Devine

#### Instructors

Dr. Gupta

Dr. Shih

#### Date Submitted

October 9, 2015

## Table of Contents

<b>Table of Figures</b> .....	<b>iii</b>
<b>ABSTRACT</b> .....	<b>iv</b>
<b>1. Introduction</b> .....	<b>1</b>
<b>2. Project Scope</b> .....	<b>2</b>
2.1 Background Information.....	2
2.2 Need Statement .....	3
2.3 Goal Statement.....	3
2.4 Constraints .....	4
<b>3. Methodology</b> .....	<b>6</b>
<b>4. Deliverables</b> .....	<b>8</b>
<b>5. Product Specifications</b> .....	<b>9</b>
5.1 Motors .....	9
5.2 Impellers .....	12
5.3 Materials .....	14
<b>6. Assign Resources</b> .....	<b>19</b>
<b>7. Conclusion</b> .....	<b>20</b>
<b>References</b> .....	<b>21</b>
<b>Appendix A</b> .....	<b>23</b>

## Table of Figures

Figure 1: House of Quality .....	6
Figure 2: Brushed DC Motor .....	9
Figure 3: Brushless Motor .....	10
Figure 4: AC Induction Motor .....	11
Figure 5: Axial Impeller.....	12
Figure 6: Radial Impeller .....	13
Figure 7: Housing for Radial Impeller.....	13
Figure 8: Semi-Axial Impeller .....	14
Figure 9: Displays the Fiberglass’s sound absorption performance varying by thickness [20] ...	15
Figure 10: Displays the Cellulose’s sound absorption performance varying by thickness [21]...	16
Figure 11: Displays the comparison of thermal conductivity coefficient “K” of pyrogel xt against the others familiar competitors [22].....	17
Figure 12: Representation of thickness comparison of pyrogel xt to other familiar materials required to insulate a 6 inch pipe operating at a high temperature [23] .....	18

## ABSTRACT

There is a fundamental problem with the current design of many hair dryers, which is the fact that they produce an unappealing amount of sound during use. This present endeavor will seek to design a hair dryer that is quieter than what is currently on market, while also maintaining low cost of manufacturability. Optimal results to this project will include a working and effective prototype, as well as a business plan for marketing and commercializing the product. In order to reduce the sound produced, Team 6 will target and aim to improve the loudest noise sources that are currently in hair dryers, with the highest-ranking being the fan and its intake.

The top noise producers being the motor, fan/intake. The motor noise will be improved by choosing between three different motors: a brushed DC, brushless DC, and an AC induction motor. Each motor producing less sound than the other. The impeller choices will be chosen from three as well: a radial impeller, semi-axial impeller, and axial impeller; each of the impellers being cheaper to produce than the last. The final system will incorporate some combination of motor and impeller that will produce the least amount of noise.

# 1. Introduction

The objective of this report is to clearly outline the project plans and product specifications. The task at hand is to create a hair dryer whose noise output is significantly less than that currently seen in the hair-dryer market. This project also asks for us to analyze the entrepreneurship side and to generate a product that is suitable for the current market by creating a device that meets safety regulations, provides equivalent drying quality, and also is quieter. With this in mind, all design aspects must be made to ensure the product can easily be transferred to the market and be massed produced. The project sponsor is Dr. Michael Devine and he is very knowledgeable on entrepreneurial endeavors. His advice will be thoroughly sought after when making decisions about our product in commercialization aspects. The advisor for our project is Dr. Cattafesta, who is an expert in the acoustics field. His expertise will be sought on technical aspects in the design.

Currently the average hairdryer produces a sound level that is bothersome, invasive and harmful. Some examples include salons where hair dryers are constantly in use producing excessive noise pollution, or the case where someone is sleeping in close proximity of someone needing to dry their hair. The average hair dryer also produces a sound level that can be threatening to one's long term hearing with prolonged use. Being that there is this inherent problem associated with the current hair dryer, it offers a niche in the market for this project to fit a need. A solution that would be deemed fit is to be able to offer the same amount of power output, while reducing the noise that it produces compared to current hair dryers in market.

This assessment will begin with some background on the current state of hair dryers to give insight into some design features, some leaders in the current market and current technology used in hair dryers. The need statement will be defined to outline the current problem that is intended to be solved. The goals for our project will be clearly described along with the constraints that our design will be bounded by. The methodology of our project will include a layout of the major tasks that are planned to be completed during the project. This will be followed by a more detailed task list in the form of a Gantt chart. It will outline the entire duration of our project on a preliminary basis that may be improved as the design comes together. The report will conclude with a detailed list of our design and performance specifications.

## 2. Project Scope

### 2.1 Background Research

Hair dryers are the one of the most widely used hair-related instruments, seen in both personal and commercial environments with the purpose to style and dry hair quicker. Their primary use is to speed up the time that it takes to dry hair. In order to make hair dryers perform efficiently, their heating elements and air flow rate must be extremely effective. However, this causes one big problem: the level of sound created by the hair dryer. It has been observed that people are unhappy with the noise that is associated with using a hair dryer. The typical hair dryer produces anywhere between 80 - 90 decibels [1]. This not only creates an unpleasant environment for the person getting their hair dried, but also can produce undesired noise in both a business and to those sharing the room. Many sources cite that noise-induced hearing-losses begin at the sound level of 85 decibels [2], thus making the average hair dryer detrimental to ones hearing over time.

Fundamentally, a hair dryer is a simple electromechanical device. On the most basic level, it is a heating element that uses resistance in wires to produce heat, then using a fan to continuously force air over them creates a constant stream of hot air. This means of heat transfer is called *forced convection*. The progression of the hair dryer design has been happening since the 1920's when the first of its kind was invented. Over the years, its design has changed to a lighter, safer, and more powerful device. The early models were made of steel and zinc, which only produced 100 Watts, unfortunately resulting in numerous casualties from electrocution. The standard today in heat resistive plastics, generally up to 2000 Watts, a plethora of safety measures have been implemented that have nearly eliminated all hair drying fatalities. Most of the safety measures include mechanisms that trip the circuit if it experiences unusual current, or reaches a certain temperature.

Meanwhile, the problem of noise pollution by hair dryers has been undertaken by multiple companies, one of these being Revlon, to produce a "quiet" hair dryer. The "Revlon RVDR5045 Quiet Pro Ionic Dryer" was claimed to be 50% more quiet than the leading brands, however this product is unfortunately no longer on the market [3]. That suggests the product was not quiet enough to satisfy the market-consumers. There are two other companies that have successful

products which claim to be the quietest hair dryers. The “Centrix Q-Zone” hair dryer is said to produce roughly 10 less decibels than its competitors. This product is sought out mostly because of its low price and exceptional performance, while also allowing its user to speak on the phone due its low sound production [4]. The second is the “Envy + Onyx” made by Velecta-Paramount, which is said to produce only 64 decibels, but with its higher price tag of \$300 (and being built by hand in Paris), it is not as popular as the Centrix [5] model. Both companies suggest that their products utilize advanced noise-cancelling technology; this could be a result from using high-tech motors which both companies place at the center-point of their designs. Unfortunately, both companies do not suggest the finer details of their technology to reduce noise, but the motor could suggest to be the first step, along with insulation to reduce vibrations. Dyson, a company that is well known for producing high-tech vacuums and fans among other novel ideas, patented and produced the sleek bladeless fan technology that is

The noise-cancelling technology via high-tech motor was achieved by Dyson, a company that is well known for producing high-tech vacuums and fans among other novel ideas. The idea behind the noise-cancelling technology was to eliminate the use of blades that propel the air out of a nozzle. The high-tech, neodymium magnet-engine that is employed in every Dyson product helps reduce turbulence by pulling air in from the atmosphere at a relatively high velocity [6]. Ultimately, the idea of reducing the turbulence from the air flow is the major key in reducing the sound produced by air-multipliers such as fans, or even extended toward hair dryers.

## 2.2 Needs Statement

Existing hair dryers are too loud. Currently, the average hair dryer on the market operates between 80 and 90 decibels. This type of noise can be damaging to ones long-term hearing and also cause unwanted disturbances to the user’s environment. Currently, the top-performing, quiet hair dryers on the market are upwards of \$300. This creates a need for a hair drying device that is both quiet and effective, while also remaining at an inexpensive price point.

## 2.3 Goal Statement

The goal of this project is to design and build a working prototype of a hand-held hair drying device that significantly reduces the noise output compared to that is currently available; it must

also be roughly equal in its effectiveness of drying hair. Along with designing a quieter device, a business model of the manufacturability and marketability of the current design will be done. Ultimately, the final package submitted will include both a working prototype, as well as this in-depth market study.

## 2.4 Constraints

Team 6 was set with only two restraints: the device needed to be quieter than current hair-dryers, and that the budget for this project is \$1500. The product is also being designed for the market, therefore there will be additional constraints, such as being manufacture-friendly and affordable. Some aspects of a hair-dryer design have become a “norm” in most user’s experiences. Although, in this case, the user expects a safe and effective heat output, a light-weight product, and an inclusion of all standard safety measure. These, along with other constraints and needs that Team 6 deems necessary, will be listed below to give an overview of where the design is bounded.

- Budget of \$1500, yet can be extended with special permission
- Noise generated less than 70 db
- Must weigh less than 1.5 lbs
- Heat of exposed parts may not exceed 115° F
- Have maximum size dimensions less than 10 x 10 x 4 inches (length x height x width)
- Insulation and casing needs to be melt-resistant at any usable temperatures
- Safety components, must include ground fault circuit interrupter for immersion protection

Elaboration on some key constraints will be given below.

- Budget – This budget will be used for the prototyping and testing of the device.
- Noise Output – The team evaluates a “quieter” hair-dryer constitutes a sound output of less than 70 dB.
- Weight – The device should not cause struggle or be uncomfortable to hold during use.
- Temperature Output – The device must be limited on the heat that it can produce to ensure safe use and no burns occur.
- Size – The size of the design should be similar to current products on the market due to a “norm” associated with current hair dryers.



- Safety – Certain safety measures are required to be incorporated in hair dryers based on regulations from the Consumer Product Safety Commission. This includes a means to prevent electrocution from immersion in water [7].

### 3. Methodology

Team 6 will produce a device that is effective at drying hair and is not unpleasant nor damaging to ones hearing during use. Starting any project from scratch requires a lot of foundation-work and background research in order to determine the best possible method of moving forward. The team will need to determine the type of technology that is used in current hair-dryers, as well as other plausible technologies that could be integrated. The reverse engineering of hair-dryers will also aid in understanding the intricacies of these devices. Other topics of interest to study that will help in design include air flow using fans, acoustics and circuitry. The main focus in reducing sound from the device is to target the highest source of noise; this will be the most effective means at reducing the overall sound produced.

Team 6 constructed a House of Quality diagram (Figure 1) in order to determine the most important customer requirements for the product, as well as the engineering design characteristics, that are most significant. This is important for the team to effectively design around the things that make for a better product. Research that has been done was incorporated into its creation [8]. The top customer requirements were that it must be quiet, dries effectively, and operates safely. The highest ranking engineering characteristics were the air supply source, the type of motor and the speed of the output flow.

HOQ

Customer Requirements	CI	Engineering Characteristics							
		Air supply source	Flow Speed Control	Convert Electricity to Heat	Temperature Control	Protection to User	Electric Supply	Type of Motor	Material Selection
Quiet	10	10	6	0	0	0	0	6	3
Dries Effectively	10	10	10	10	10	0	3	6	0
Ease of use	6	0	3	6	3	0	0	0	0
Operates safely	10	0	0	3	3	10	6	3	0
Light Weight	6	3	0	0	0	0	0	3	10
Ergonomic	3	0	3	0	3	0	0	0	3
Variable Heat Settings	6	0	0	10	10	0	0	0	0
Variable Speed Settings	6	6	10	0	0	0	3	10	0
Affordable	3	6	0	0	0	3	3	6	6
Easy to clean	3	0	0	0	0	3	0	3	0
Score		272	247	226	217	118	117	255	117
Relative Weight		17.34	15.74	14.4	13.83	7.52	7.46	16.25	7.46
Rank		1	3	4	5	6	7	2	7

Figure 1: House of Quality

Once sufficient background research was done, the team will progress to testing of components and creating conceptual designs where multiple ideas will be implemented. The team will look to use parts from purchased hair-dryers in order to reduce costs; other needed parts will be ordered once designs are finalized. The team plans on constructing the circuit component of the hair dryer during the design-phase, because this is something where a majority of the work can be done simultaneously, and minor changes can be made as permanent designs come about.

A working prototype is aimed to be completed by the end of the fall semester. This will leave plenty of time to perform enhancements and testing in the spring, as well as give some leeway in this design process if/when delays occur.

## 4. Deliverables

The group's work breakdown structure can easily be viewed in the created Gantt chart listed in the appendix of this report. It contains group tasks per scheduled submission deadlines for the course requirements, and also includes subtasks which describe the specific details of what must be accomplished prior to submission dates. There are also user-created tasks included in the chart which are not mandatorily established by the Senior Design course; these tasks are intended for the group members to complete project-related items in order to progress with their future plans toward the development of a prototype. The current Gantt chart is scheduled to the end of the initial senior design course.

## 5. Product Specifications

### 5.1 Motors

Most hair dryers use either DC or AC motors to rotate a fan in order to create an air supply source. Less expensive hair dryers on the market use DC motors to ensure a cheaper design for consumers, however these have many disadvantages that range from higher noise levels of 82 dB to less efficient dryer performance with respect to drying time. AC motors on the other hand are much quieter (62dB - 70dB) and have higher performance with respect to drying hair.

This does not mean that AC hair dryers are perfect by no means [9]. AC hair dryers are more expensive and weigh a great deal more than DC motor hair dryers.

DC motors can be divided into two different groups: brushed and brushless; both have their own advantages and disadvantages. The similarities between the two types of DC motors are that both run at 5000 - 6000 rpm; both are louder than AC motors [9]. Also, both cost about the same amount and operate using a direct current, hence the abbreviation DC. Both depending on which model is purchased last between 400-700 hours, noting that the brushless will last longer than the brushed DC motor for reasons stated later in the text [9]. This is where the similarities between the two DC motors end. The brushed DC motor typically provides more torque than a brushless motor but does not last as long as a brushless because its brushes shown in Figure 2 wear down after a while.

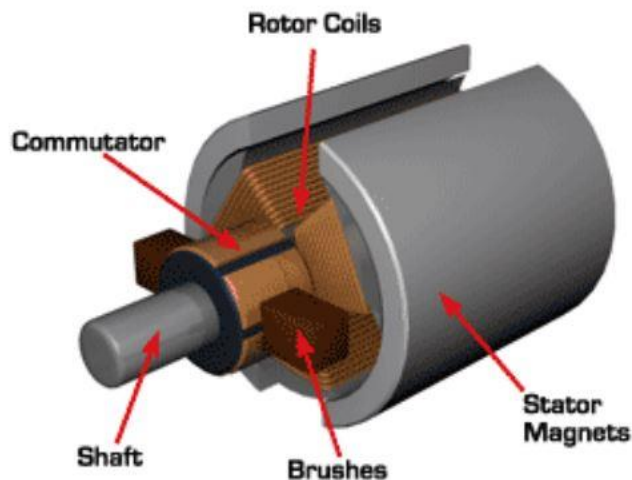

Figure 2: Brushed DC Motor

Because of the brushes within the motor, it is a louder product to operate compared to a brushless motor. The chosen brushed motor for this project would have to include specifications of 6 - 24 Volts, and must run at 6000 rpm; this is the typical engine for hair dryers [10]. This motor will be the control because it's similar to typical hair dryer motors, and will be used with different fan blades and inlets that could lessen the noise level of the system. The second DC motor is a brushless motor which creates less noise than the brushed DC motor due to the lack of brushes. This motor acts somewhat like an AC motor where the motor is supplied by a DC electric source, but that DC electric source is converted into an AC electrical signal to power the motor as seen below in Figure 3. Brushless motors last much longer than brushed motors because of the lack of brushes which will allow for a more reliable and longer lasting product, which means a more valuable product [11].

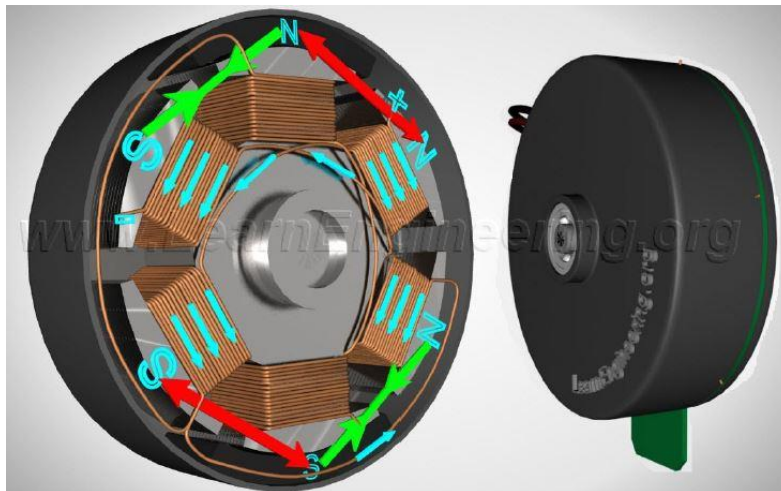

Figure 3: Brushless Motor

The DC brushless motor that would be chosen for this design would have to run at 6 - 12 Volts, and in this case, since brushless motors are based off of a value of kV (rpm per volt) the motor will have to be 500 kV -1000 kV [10]. This kV amount will allow for a 6000 rpm rating, which is suitable for a hair dryer [9]. The reason for choosing a brushless DC motor is to compare sound production compared to the brushed DC motor using the same fan blades. The brushless DC motor would be bought from *hobbyking.com* because of their wider array of motor choices than *Amazon*, and the brushed would be purchased from *Amazon*. The brushed DC motor should cost around \$6, while the brushless DC motor should cost around \$13; this is considerably more than the brushed motor, thus pricing will play a role in the decision process.

AC motors are used in more expensive hair dryers for many reasons, which include less noise production, and a stronger air flow which allows for a quicker hair drying. When an AC motor is placed within a hair dryer, it typically makes the hair dryer much heavier than a DC powered hair dryer. However, AC motors last between 700 - 1200 hours, which is considerably much longer than DC motors [9]. AC motors run on what is known as an alternating current, which when put through coil windings creates an electric magnetic field (EMF) that creates rotational movement [12]. The electricity is inducted within the AC motor as seen below in Fig. 4 rather than directly transferred like in a DC motor [13].

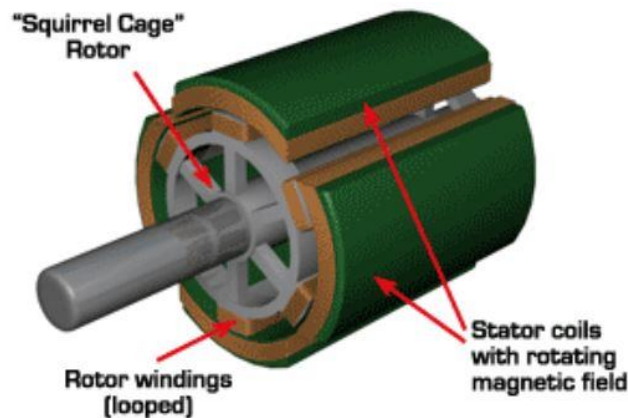

Figure 4: AC Induction Motor

The AC motor would have to run at 48 - 220 Volts and must run at 2000 rpm or less because typical AC hair dryers run at 1500 - 2000 rpm [9]. The motor will also cost in the vicinity of \$20 from *aliexpress.com* without shipping costs [14].

Dyson is known for their high performance neodymium digital motors that contribute to a very high suction within vacuums. However, Dyson also employs its high performance motors in fans and hand dryers. The hand dryers, for instance, produce 80 dB of sound and their fans claim to produce 75% less noise than the leading brands [15]. This means that a quiet hair drying system could be produced by employing a Dyson neodymium digital motor; however, because this is property of Dyson, the product would not be marketable due to copyright laws. However for testing purposes, a Dyson motor may be purchased for \$75 from *vacuum-direct.com*, and thus a dissection of the motor may allow for the design of a similar yet different motor allowing for the marketing of the hair dryer [16].

## 5.2 Impellers

There are three different impeller designs that will be utilized in this project, and these three are axial, radial and semi radial designs. All of which would be created using a 3D printer and made of plastic, so that the price of the hair dryer can be kept at a minimum. This will also allow for a more detailed test because each design can be changed slightly by adding more blades and changing the pitch.

Axial impellers are the most common form of air-source multiplier for hair dryers in today's market, because it is easy to manufacture and can be made of cheap plastic, thus making it a cheap design. The way an axial impeller works is that it pushes air parallel to the shaft of the driving motor as seen below in Fig 5. In most hair dryers, the axial fan sucks air through a lint screen and forces it through the nozzle of the hair dryer [17].

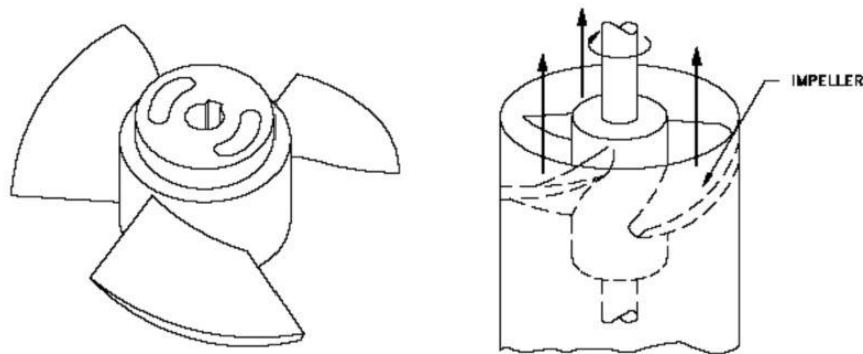

Figure 5: Axial Impeller

Axial impellers can be designed to have different style of blades to make for more aggressive air flow or more blades can be added for the same effect. The axial impeller design can be changed and modified very easily compared to the other two designs thus this design will be the easiest to test.

Radial Impellers were used for older models of hair dryers, but have been replaced by axial designs in today's market. This could be because the radial impeller is more difficult to manufacture cheaper than the axial design. However, for testing purposes the radial design will be used in the hair dryer design to ensure all bases are tested for a quieter experience. The radial impeller design sucks in air through a small opening on one side, and shoots the higher velocity air directly outward 360 degrees [18], as seen ahead in Figure 6.



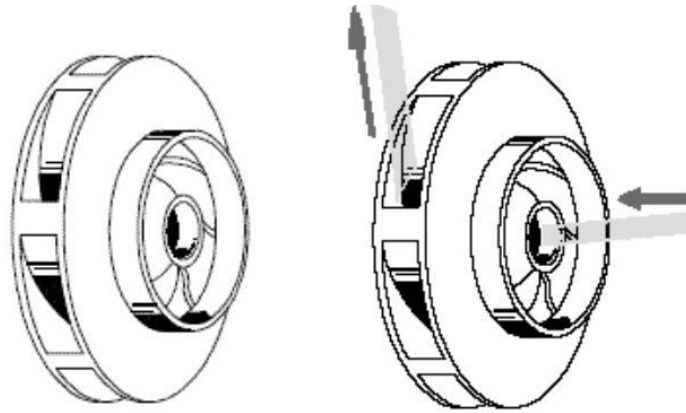

Figure 6: Radial Impeller

Because the radial impeller shoots the higher velocity air in a radial fashion, a housing must enclose the radial impeller in order to direct the air in the desired direction [18], as seen below in Figure 7. This allows for the air to be controlled and utilized in a blow dryer; the downside however, is that the added encasement adds extra weight to the blow dryer. This extra added weight may be made up in other parts of the design, but regardless, the axial impeller saves more weight. Just like the axial impeller, the radial impeller can be freely designed, though more difficult, may have more aggressive blades or added number of blades.

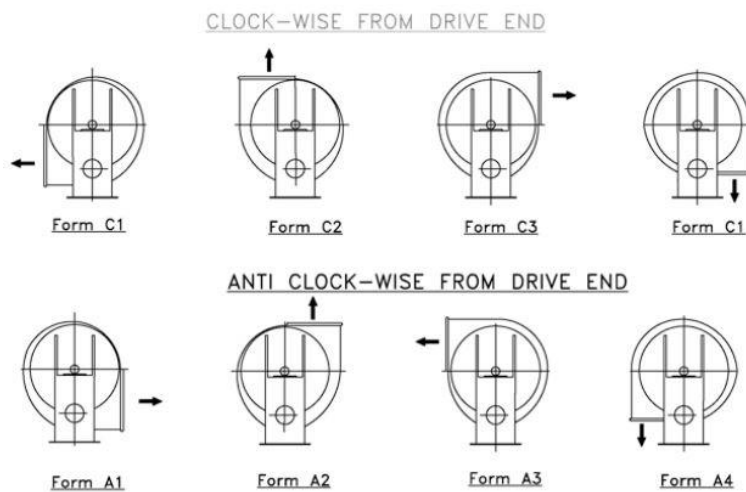

Figure 7: Housing for Radial Impeller

The semi-axial impeller or semi-open impeller design is used in turbos for vehicles and Dyson's neodymium digital motors. The design has never been used before in a hair dryer, but very well may be the key to solving the noise level of hair dryers. The semi axial impeller design sucks in

air through the eye and forces the more energized air out of its vanes much like the radial impeller however the semi-axial design is made with less material and is easier to manufacture [19], as seen in Figure 8.



Figure 8: Semi-Axial Impeller

The semi-axial impeller can produce a very energized amount of air compared to its size, and due to its design, it does not make as much noise compared to the axial impeller at high rpm [19]. The axial-impeller may prove to be the more dissed choice in the quieter-hair-dryer design because of its placement between the axial and radial impeller.

### 5.3 Materials

Prior to describing the importance of the parameter design varying from the measurements to its features, it is imperative that the design itself ensures that all of the components are performing to its according capabilities. Upon the decision of strategically positioning the components to function properly along with minimizing noise, and ensuring the heat flow to be as efficient as possible, the encasement can be implemented to serve as a heat insulator and sound absorber. In previous cases, a majority of the hair dryers used plastic which serves as a handling grip, flow processor, protects components from harm, decorative style, and ease of cost. If this material can be substituted into performing the same requirement as plastic, but with an addition of a sound absorbent aspect, and even though sound cannot be completely diminished from either the components or the output flow, the material can at least serve its purpose to absorb sound and does not reflect any disturbance waves which may vibrate and damage the components that are encased.

Upon researching, our top priority is safety before quality needs, such as if mass producing a product that had been imbedded materials that cannot be recyclable then the environmental cycle is not satisfactory toward the overall global community. In other words, any materials that are not environmentally safe, they cannot be used in this case. From the quality needs that are desired, two materials that were focused came in conflict: polyurethane and polystyrene. Polyurethane serves as a good heat insulator and a sound absorber, though it could not be recycled, thus is a waste. Similarly to polyurethane, polystyrene serves the same needs though the only concerning issue is that the safety precautions can range from safe-to-dangerous in multiple case scenarios, due to little studies and vague claims; this material cannot be used.

As for the materials that had satisfied the environmental safety, fiberglass, cellulose, pyrogel xt, and mineral wool are chosen to be on the list that should be fixated. Fiberglass is considered to be an excellent non-flammable heat insulation material, with its ease of manufacturing capabilities and also serves as a good noise reduction capabilities, it was considered to be a good start to reaching the problem.

Fabrisorb™ Wall panel – Sound Absorption Coefficients						
6-7 PCF Glass Fiber	125Hz	250Hz	500Hz	1KHz	2KHz	4KHz
1"	.14	.27	.80	1.11	1.14	1.14
2"	.22	.81	1.24	1.30	1.21	1.16

Figure 9: Displays the Fiberglass's sound absorption performance varying by thickness [20]

Fixating on the main goal which is to reduce any noise emitting from the component, and ensuring that there are no feedback vibrations, sound (or noise) absorption is the main criteria. From observation listed the range of 1 - 2 inches, performance varying on each frequency ranging from Hz - kHz. Implementing this feature within our hair dryer requires a safety gate where if fiberglass is broken, it could result in physical damage to the lungs, skin, and eyes. Despite the result, it had passed the environmental safety of recycling; this feature still performs excellently, but fiberglass is created from fine strands of glass which formed from glass shards/dusts.

Shifting to the cellulose, this specimen has been deemed the most eco-friendly forms of heat insulations in the market. Created from recycled cardboard, paper, and other similar materials that

comes loose in those forms, this material contains no oxygen molecules within its structure, thus making it an outstanding non-combustible feature.

CFAB Cellulose Panels – Acoustical Testing Data						
Thickness	Absorption Coefficients @ Octave Band Frequencies (Hz)					
	125	250	500	1,000	2,000	4,000
½"	0.05	0.09	0.33	0.64	0.87	1.01
1"	0.09	0.26	0.84	1.05	1.05	1.05
1½"	0.14	0.40	0.93	1.09	1.03	1.03
2"	0.39	0.63	1.18	1.11	1.06	1.09

Figure 10: Displays the Cellulose's sound absorption performance varying by thickness [21]

Comparing the data towards fiberglass with cellulose's thickness, despite its lack of tolerance at some frequencies, and shown at some strong points, cellulose would fall into the category of choosing where it is considered safer than fiberglass, unless a screen protector had been created. The only side effect to cellulose that had been detected is allergies to newspaper dust.

Prior to the concern of heat insulation rather than the noise reduction, pyrogel xt would be the main choice in this case if temperatures are incredibly high. With its flexibility that deforms under compression, resistance in high impact loads, light weight, fire resistant, hydrophobic, and environmental friendly, the material is certainly the main choice under hot temperature applications.

**Aerogel Insulation Materials Have the Lowest K-Values of Any Industrial Insulation**

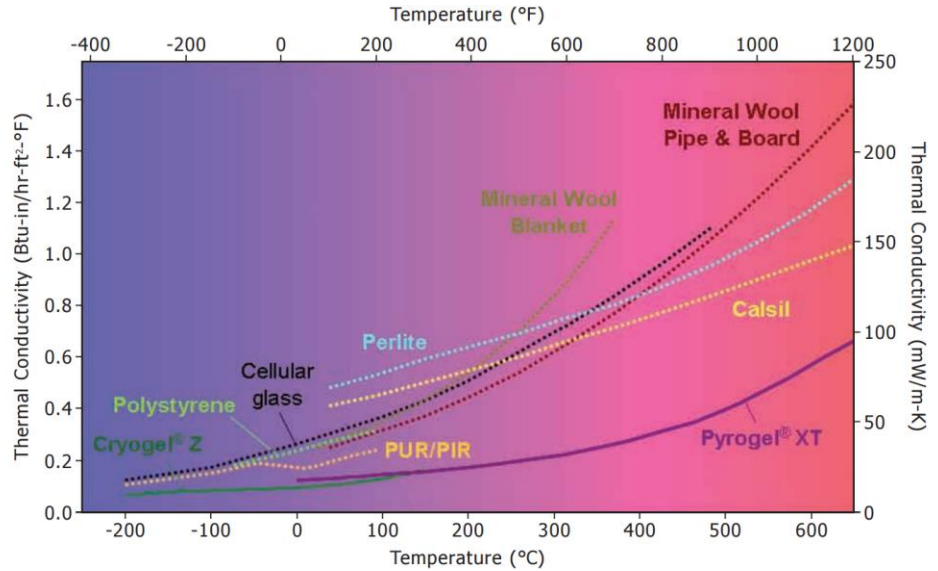

Figure 11: Displays the comparison of thermal conductivity coefficient “K” of pyrogel xt against the others familiar competitors [22]

Above lists the pyrogel’s performance under temperature conditions where the thermal conductivity can be defined as the rate of heat transfer through the specimen. The graph shows that as the pyrogel xt absorbs the temperature which increases its ability to maintain the heat to itself, and is significantly lower than other materials that are listed familiarly such as mineral wool, polystyrene, and cellulose glass. Despite mineral wool not being recognized as the others that are focused, the material is a downgrade from fiberglass. Mineral wool is environmentally friendly, and comes in many forms due to its ability to be bonded by the elements such as basalt, slag, or steel; it also serves as a good non-combustible feature such as cellulose. There is no recorded side effects, which is a good sign, but the danger of it is that the material is not fire resistant

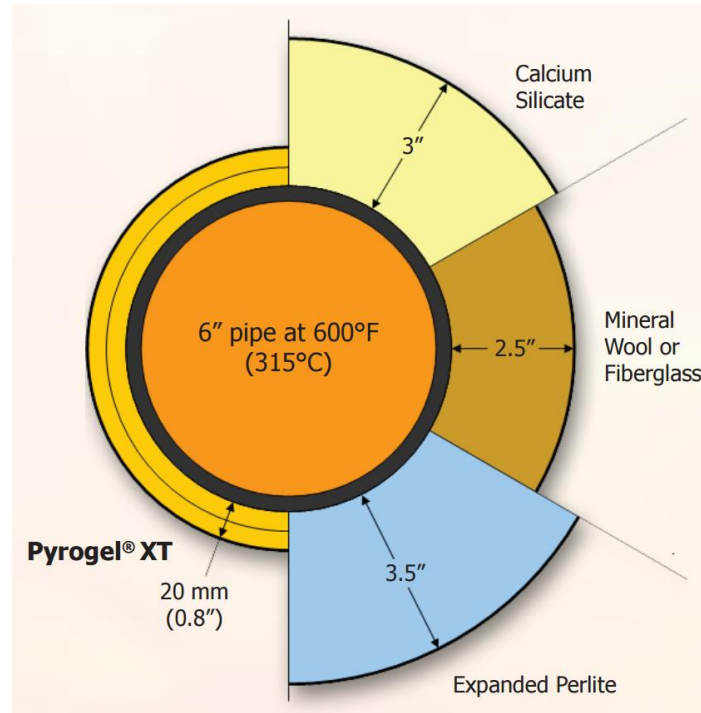

Figure 12: Representation of thickness comparison of pyrogel xt to other familiar materials required to insulate a 6 inch pipe operating at a high temperature [23]

Not only was the temperature insulation already significant, but the demanded thickness is also impressive compared its competitors. With only a margin of less than an inch, pyrogel outrivals the mineral wool and fiberglass by a factor of nearly three times.

At this point in time, if the temperatures of the hair dryer are concerned, then pyrogel would be the first pick, secondly mineral wool would be the next priority due to its safety remark compared to fiberglass (unless the fiberglass is always intact and cannot be destroyed). Prior to noise absorbent (which was the main problem), cellulose would be the safer tradeoff than fiberglass. These specimens must be implemented to nearby components that are inside the interior whether they generate noise or heat. Prior to the exterior should not be of a concern, as long as it is adhesive enough for grip, and, if and only if, the performance of the selected specimens within the interior has performed its requirement.

## 6. Assign Resources

There are multiple current resources utilized by the group. The first of which is the internet; the group has used this resource in order to obtain and cite publications that are oriented toward the disassembly/assembly and component-comprehension of the hair dryer. The group's secondary resource is their appointed advisor. This individual provides technical supervision and motivational support for the group; his job is not only to provide assistance with possible issues, but also to point the group in a reasonable direction. The final resource (the most viable resource) are the actual group members. Mark Johnson is not only the team leader of the group, but also is the individual who delegates tasks to other members, maintains the quality of the group's overall activity and progress, controls the schedule of events, edits final reports, and provides technical engineering support toward the production of the group's project. Peter Van Brussel is the person in charge of financial expenditures, provision of detailed measurement tools, webpage design leader and assistance in technical fluid-dynamics knowledge. Kiet Ho is responsible for providing expertise as one of the two lead mechanical engineers in computer aided drafts and designs for the hair dryer; he also is responsible for including the mathematical support which correlates to the information created and tested via CAD, Matlab, Mathcad, or any other useful software programs. Shawn Eckert is the other leader in engineering designs, but is not limited to just this task; he is also responsible for maintaining communications between the group and the sponsors/advisors/instructors. Nevertheless, each individual in the group is not limited to their specified tasks; all students will provide assistance to each other as needed.

## 7. Conclusion

In conclusion, the group has revised their needs and goal statement; this has allowed them to re-evaluate what must be achieved to progress into developing a conceptual design. On that same note, several product items, product specifications, material options have been selected for potential usage in the future. Also, by utilizing a re-formatted House of Quality, the group is able to narrow down and prioritize their options. By applying this method, product selection and creation has become easier to predict in the coming weeks. With further understanding of the products-in-mind, selecting parts for purchase and assembly should prove to be a plausible task. Also, with the implementation of a Gantt chart, planning out future tasks and appointments would be easier to manage, due to the visibility of a physical schedule of events.



## References

- [1] <http://www.asha.org/public/hearing/Noise/>
- [2] <http://www.nidcd.nih.gov/health/hearing/pages/noise.aspx>
- [3] <http://www.amazon.com/Revlon-RVDR5045-Quiet-Ionic-Dryer/dp/B007PAIGYA>
- [4] <http://besthairdryerreviews.net/centrix-q-zone-quiet-dryer/>
- [5] <http://www.velecta-paramount.com/blowdryers/envy-onyx.html>
- [6] <http://www.dyson.com/Fans-and-heaters/cooling-fans.aspx>
- [7] <http://www.cpsc.gov/PageFiles/132317/hairdryers.pdf>
- [8] “*Engineering Design Process(2)*”. Retrieved January 23, 2015. Microsoft Office PowerPoint Presentation. [Slide # 33 / 111]. Dr. Raturaj Soman, soman@cap.fsu.edu
- [9] <http://visual-makeover.com/hair-dryers/>
- [10] [http://hobbyking.com/hobbyking/store/\\_\\_223\\_\\_59\\_\\_Electric\\_Motors-TURNIGY.html](http://hobbyking.com/hobbyking/store/__223__59__Electric_Motors-TURNIGY.html)
- [11] <http://www.learnengineering.org/2014/09/DC-motor-Working.html>
- [12] <http://www.learnengineering.org/2013/08/three-phase-induction-motor-working-squirrelcage.html>
- [13] <http://www.orientalmotor.com/technology/articles/AC-brushless-brushed-motors.html>
- [14] <http://www.aliexpress.com/item/FREE-SHIPPING-2-PCS-Dc-220v-series-motor-hair-dryermotor-50w-20000-speed-motor-AC/2016895142.html>
- [15] <https://www.dyson.com>
- [16] <http://www.vacuum-direct.com/dyson-dc18-25-panasonic-motor.aspx>
- [17] [http://www.mi-wea.org/docs/Prosoli%20-%20Centrifugal\\_Pumps\\_Overview.pdf](http://www.mi-wea.org/docs/Prosoli%20-%20Centrifugal_Pumps_Overview.pdf)
- [18] [http://www.akamaiuniversity.us/PJST13\\_1\\_24.pdf](http://www.akamaiuniversity.us/PJST13_1_24.pdf)
- [19] <http://www.mcnallyinstitute.com/14-html/14-02.htm>
- [20] “*Acoustical Surfaces, Inc. Fabric Panel.*”. Opened October 8, 2015. Website. Acoustical Surfaces, Inc – All Rights Reserved © 2014. sales@acousticalsurfaces.com.
- [21] “*Acoustical Surfaces, Inc. Cellulose Panel.*”. Opened October 8, 2015. Website. Acoustical Surfaces, Inc – All Rights Reserved © 2014. sales@acousticalsurfaces.com.
- [22] “*Pyrogel®XT Flexible Industrial Insulations for High-Temperature Applications.*”. Retrieved October 8, 2015. Adobe Acrobat Reader. [Page # 4 / 4]. Aspen Aerogels, Inc. © 2010.

- [23] “*Pyrogel®XT Flexible Industrial Insulations for High-Temperature Applications*”. Retrieved October 8, 2015. Adobe Acrobat Reader. [Page # 3 / 4]. Aspen Aerogels, Inc. © 2010.

# Appendix A

TASKS	Completion	Start Date	End Date	TASKS	Completion	Start Date	End Date
Bi-weekly Staff Meetings	<input type="checkbox"/>	09/07/15	12/01/15	Midterm Presentation I: Conceptual Design	<input type="checkbox"/>	10/16/15	10/22/15
Advisor Sessions	<input type="checkbox"/>	09/07/15	12/01/15	Selection of Speakers	<input type="checkbox"/>	10/16/15	10/16/15
Code of Conduct	<input checked="" type="checkbox"/>	09/07/15	09/11/15	Structure of Powerpoint	<input type="checkbox"/>	10/16/15	10/16/15
Submission	<input checked="" type="checkbox"/>	09/07/15	09/11/15	Practice	<input type="checkbox"/>	10/18/15	10/18/15
Needs Assessment	<input checked="" type="checkbox"/>	09/14/15	10/01/15	Presentation	<input type="checkbox"/>	10/20/15	10/22/15
Divide Tasks	<input checked="" type="checkbox"/>	09/14/15	09/15/15	Project Oriented Meeting	<input type="checkbox"/>	10/18/15	10/18/15
Organize	<input checked="" type="checkbox"/>	09/14/15	09/16/15	Midterm Report I	<input type="checkbox"/>	10/19/15	10/30/15
Submission	<input checked="" type="checkbox"/>	09/25/15	10/01/15	Gather Information	<input type="checkbox"/>	10/19/15	10/20/15
Project Plans and Product Specs	<input checked="" type="checkbox"/>	10/04/15	10/09/15	Organize	<input type="checkbox"/>	10/19/15	10/22/15
Gantt Chart	<input checked="" type="checkbox"/>	10/04/15	10/09/15	Revise	<input type="checkbox"/>	10/20/15	10/22/15
Assign Resources	<input checked="" type="checkbox"/>	10/04/15	10/09/15	Submission	<input type="checkbox"/>	10/30/15	10/30/15
Design Specifications	<input checked="" type="checkbox"/>	10/04/15	10/09/15	Project Oriented Meeting	<input type="checkbox"/>	10/25/15	10/25/15
Product Specifications	<input checked="" type="checkbox"/>	10/04/15	10/09/15	Peer Evaluation	<input type="checkbox"/>	10/30/15	11/03/15
Submission	<input checked="" type="checkbox"/>	10/09/15	10/09/15	Project Oriented Meeting	<input type="checkbox"/>	11/01/15	11/01/15
Project Oriented Meeting	<input type="checkbox"/>	10/11/15	10/11/15	Midterm Presentation II: Interim Design Review	<input type="checkbox"/>	11/05/15	11/19/15
Initial Web Page Design	<input type="checkbox"/>	10/11/15	10/15/15	Selection of Speakers	<input type="checkbox"/>	11/05/15	11/05/15
Selection of Format	<input type="checkbox"/>	10/11/15	10/11/15	Structure of Powerpoint	<input type="checkbox"/>	11/05/15	11/05/15
Organization of Page	<input type="checkbox"/>	10/11/15	10/14/15	Practice	<input type="checkbox"/>	11/13/15	11/13/15
Addition of Course Content	<input type="checkbox"/>	10/11/15	10/14/15	Presentation	<input type="checkbox"/>	11/17/15	11/19/15
Inclusion of Detailed Styling	<input type="checkbox"/>	10/11/15	10/14/15	Project Oriented Meeting	<input type="checkbox"/>	11/08/15	11/08/15
Submission	<input type="checkbox"/>	10/15/15	10/15/15				

TASKS	Completion	Start Date	End Date
Project Oriented Meeting	<input type="checkbox"/>	11/15/15	11/15/15
Peer Evaluation	<input type="checkbox"/>	11/19/15	11/24/15
Final Web Page Design	<input type="checkbox"/>	11/19/15	11/24/15
Organization Layout	<input type="checkbox"/>	11/19/15	11/20/15
Finalize Stylization	<input type="checkbox"/>	11/22/15	11/22/15
Group Approval	<input type="checkbox"/>	11/22/15	11/22/15
Submission	<input type="checkbox"/>	11/24/15	11/24/15
Project Oriented Meeting	<input type="checkbox"/>	11/22/15	11/22/15
Final Design Poster Presentation	<input type="checkbox"/>	11/22/15	12/01/15
Purchase Supplies	<input type="checkbox"/>	11/22/15	11/22/15
Structure	<input type="checkbox"/>	11/24/15	11/24/15
Layout	<input type="checkbox"/>	11/29/15	11/30/15
Submission	<input type="checkbox"/>	12/01/15	12/01/15
Project Oriented Meeting	<input type="checkbox"/>	11/29/15	11/29/15
Final Report	<input type="checkbox"/>	11/22/15	12/01/15
Organize	<input type="checkbox"/>	11/22/15	11/24/15
Revise	<input type="checkbox"/>	11/29/15	11/30/15
Submission	<input type="checkbox"/>	12/01/15	12/01/15

