



Electric Vehicle Optimization



Sponsored By: Cummins

Project Definition

Background:

Many semi-truck drivers sleep in their truck cabins and power the cabins heating and cooling systems off of the truck battery. This forces the drivers to waste fuel by leaving their engine on or to go without the systems. In harsh weather conditions where heating and AC are necessities this presents a safety risk. As such Cummins would like to sell a battery-engine package that would activate or deactivate the engine as needed. In order to model this system Cummins provided us with an electric golf cart and generator. Cummins stated that the current range and operational temperature range of the golf cart were unsatisfactory.

Goal:

“To increase the current range and operable conditions of the electric vehicle by utilizing a secondary power source in efforts to apply this to semi-trucks.”

Objectives:

- Increase the lower temperature limit to -29°C .
- Incorporate a generator.
- Integrate a battery monitoring system.
- Ensure the vehicle can charge while running.
- Model design for ISX-15 diesel engine.



Figure 1. Photograph of the golf cart the proposed system will be implemented in.

Design

Golf Cart System Design:

- Generator will be stored under the rear seat of golf cart.
- Generator will activate when the battery voltage is low.
- Heating pads control the temperature of the carts' batteries.
- Motor power source changes depending on if batteries are charging.
- The maximum speed is modulated depending on motor power source.

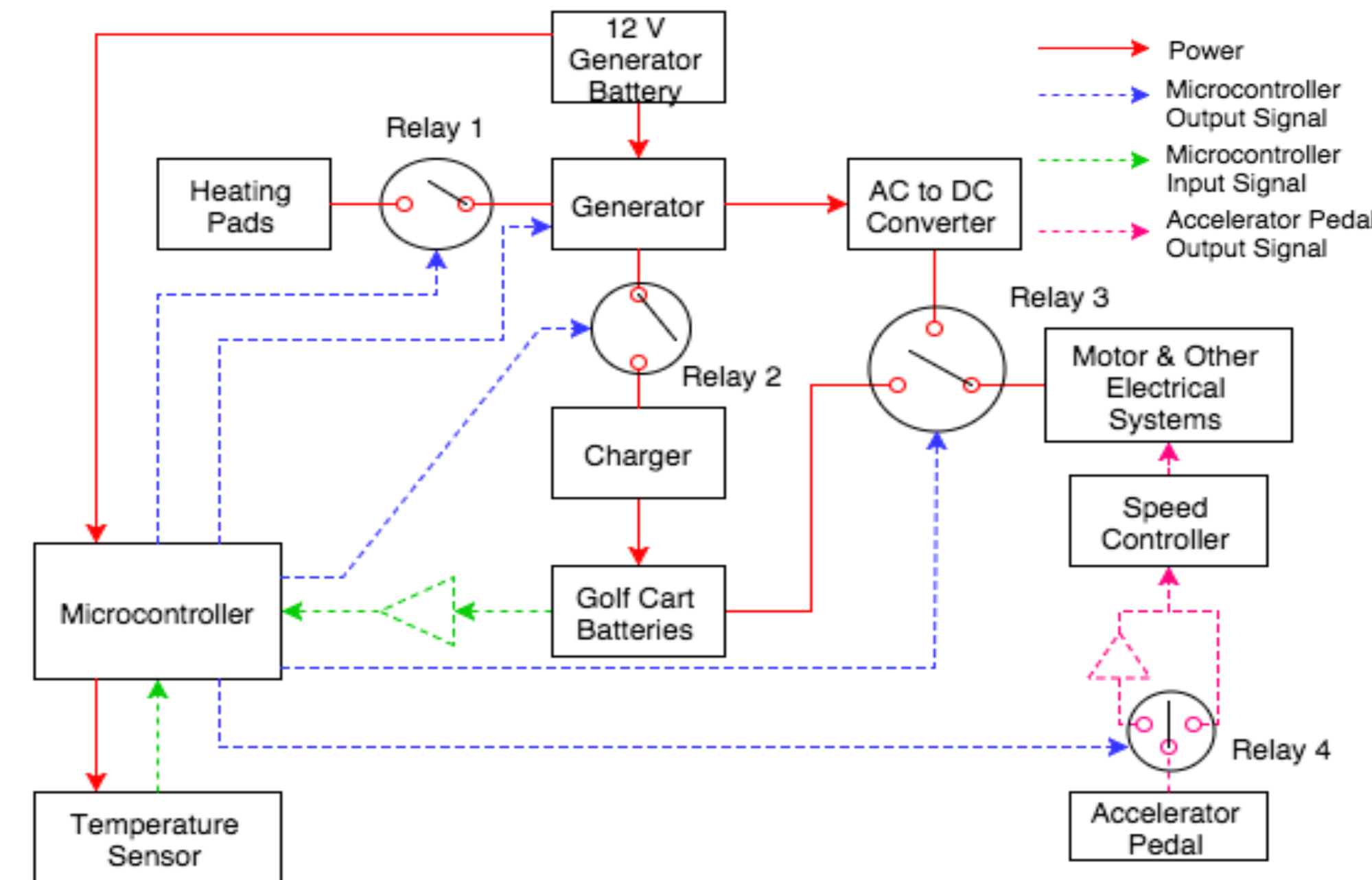

Figure 2. System diagram of the proposed design for the golf cart.

Mechatronic System

Multiple State System:

- State 1: Normal Operation
- State 2: Batteries Cold
- State 3: Batteries Charging
- State 4: Batteries Hot

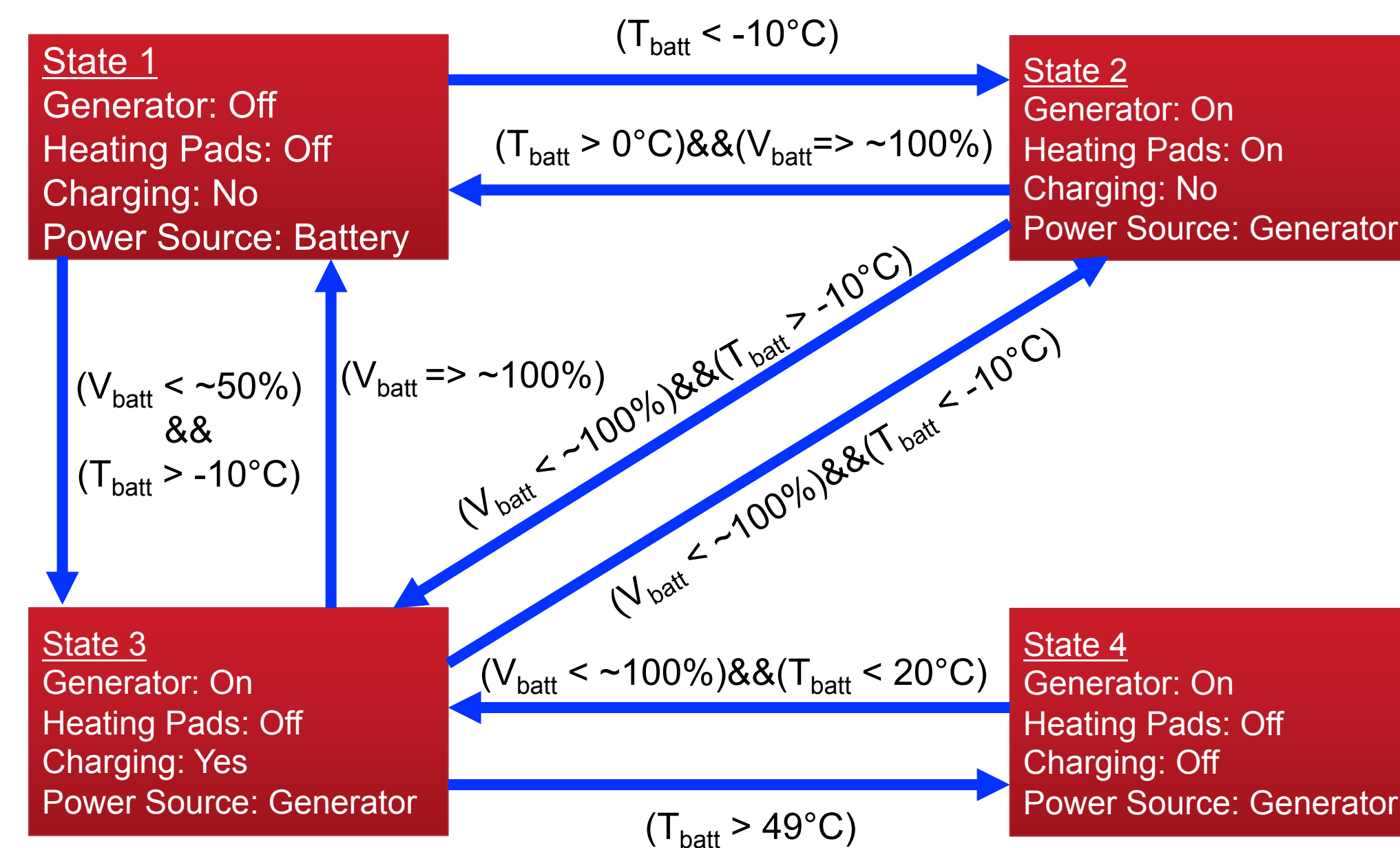

Figure 3. State Diagram of the proposed mechatronic system.

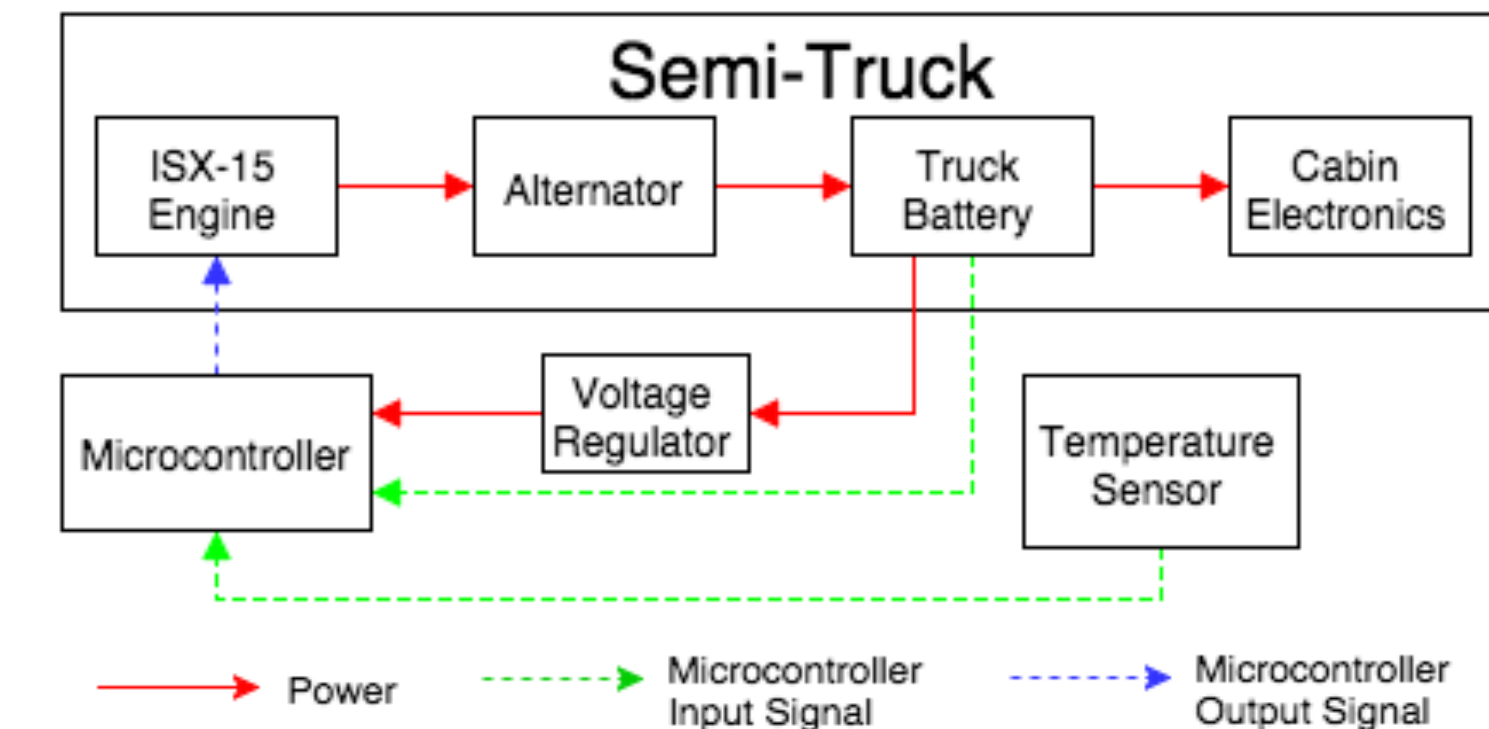

Figure 4. Adapted design for semi-trucks.

Challenges & Risks:

- Presently the golf cart is not in working condition.
- Inductive kickback during power switching.
- Difficult to test the entire system at cold temperatures.
- The charge threshold is a function of temperature.
- Ensure design compatibility with the ISX-15 diesel engine.

Future Plans:

- Create detailed design of how to mount generator to the cart.
- Work in tandem with EE team to develop necessary circuitry required for the design.
- Begin programming mechatronic system for small scale model of design.