

# Determining the Effectiveness of Oleophobic Gaskets

---

## Midterm I Report



Team Number: 1

Submission Date: 10-30-15

Submitted To: Dr. Gupta, Dr. Shih

Faculty Advisor: Dr. Oates

Authors: Heather Davidson (hld12), David Dawson (dpd13), Aruoture Egoh (aje15f), Daniel Elliott (dse13), Norris McMahon (nfm11b), Erik Spilling (eds11b)

## Table of Contents

<b>Table of Figures</b> .....	<b>i</b>
<b>Table of Tables</b> .....	<b>ii</b>
<b>ABSTRACT</b> .....	<b>iii</b>
<b>ACKNOWLEDGEMENTS</b> .....	<b>iv</b>
<b>1. Introduction</b> .....	<b>1</b>
<b>2. Project Definition</b> .....	<b>2</b>
2.1 Background Research .....	2
2.2 Need Statement .....	3
2.3 Goal Statement and Objectives.....	4
<b>3. Design and Analysis</b> .....	<b>5</b>
3.1 Project Constraints .....	5
3.2 Design Specifications.....	5
3.3 Performance Specifications .....	6
3.4 Functional Analysis .....	6
3.4.1 Ideal Gas Law .....	7
3.4.2 Pressure and Bolt Torque Relationship.....	7
3.5 Concept Generation .....	8
3.5.1 Concept #1 .....	9
3.5.2 Concept #2 .....	9
3.5.3 Concept #3 .....	10
3.5.4 Concept #4 .....	10
3.5.5 Concept #5 .....	11
3.6 Evaluation of Concepts .....	11

3.7 Detailed Evaluation of Concept Five .....	13
<b>4. Methodology .....</b>	<b>15</b>
4.1 Resource Allocation.....	16
4.2 Schedule/Deliverables.....	18
4.3 House of Quality .....	18
4.4 Risk Assessment .....	19
<b>5. Results .....</b>	<b>21</b>
5.1 Bolt Load Analysis .....	21
5.2 Pressure Distribution.....	22
5.3 Hardware Selection.....	23
<b>6. Conclusion .....</b>	<b>25</b>
<b>References.....</b>	<b>26</b>
<b>Appendix A .....</b>	<b>27</b>
<b>Appendix B .....</b>	<b>28</b>
<b>Biography.....</b>	<b>30</b>

## Table of Figures

Figure 1. Nonoleophobic (left) vs. oleophobic (right).....	2
Figure 2. Figure 2. Concept #1 and Concept #2 cross section.....	9
Figure 3. Concept #3 cross section .....	10
Figure 4. Concept #4 cross section .....	10
Figure 5. Concept #5 cross section .....	11
Figure 6. Pugh Decision Matrix for Test Rig Decision .....	12
Figure 7. CAD model of test rig Concept #5 .....	13
Figure 8. Cross sectional view of the test rig .....	14
Figure 9. Constructed HOQ using sponsor information .....	19
Figure 10. One-quarter of the test rig .....	22
Figure 11. Gasket clamping pressure distribution based on analysis results .....	23
Figure 12. Short RTD Probe .....	23
Figure 13. Pressure transducer .....	24
Figure 14. Air Valve Stem .....	24
Figure 15. Ball Valve .....	24

## Table of Tables

Table 1. Project Objectives .....	4
Table 2. Design Specifications .....	6
Table 3. Budget.....	17

## ABSTRACT

The goal of this Cummins Inc. sponsored project is to determine the effectiveness of oleophobic gaskets compared to standard nonoleophobic gaskets. This objective will be completed by utilizing on market oleophobic sealing solutions on current gasket materials as well as non-traditional gasket materials and then testing these products in an experimental test rig, which will be designed and constructed by the team. The effectiveness of the oleophobic gaskets will be assessed by comparing the respective leak rates of each gasket type under two variable temperatures and variable bolt load to that of baseline gasket leak rates. The team has performed research on types of oleophobic solutions and have investigated which of these solutions are potential candidates to create an oleophobic gasket. The test rig must be designed and built by the team so that it can test gaskets with contact oil at room and an elevated engine-like temperature, standard “low pressure” in an engine, and variable bolt load. A House of Quality showed the team that the primary engineering characteristic tested is gasket leak rate. The team used a Gantt chart to create a time dependent project plan and identified critical tasks that the team must complete in order to finish this experiment on time and successfully. The team also assigned whom is responsible for specific tasks, thus adding more detail to the project plan.

## ACKNOWLEDGEMENTS

Thank you to Parker Harwood, our Cummins Inc. liaison, for providing guidance and support throughout the project, as well as gasket materials for the team to use for baseline testing. Additionally, the team would like to thank Dr. Gupta and Dr. Shih for their oversight of the project and providing instruction to the team. Finally, the team would like to thank many faculty members, including Dr. Oates, Dr. Kumar, Dr. Hollis, Dr. Hruda, and Dr. Van Sciver, for being a source of knowledge and expertise in their chosen disciplines. Their advice and contribution has immeasurably enhanced the team's experience and taught valuable skills to the team members.

# 1. Introduction

Cummins Inc. has proposed a project to determine the effectiveness of oleophobic gaskets to reduce the measured leak rate at low pressure, large joints on engines compared to the current gaskets used on engines. Oleophobic items are items which repel oil by having a lower surface energy than the oil. A gasket is an item which is placed between two flanges to form a seal, which is meant to prevent oils from leaking to the opposite side of the flange. The theory behind the project is that if the gasket can repel the oil, it is less likely that oil will be capable of leaking past the gasket.

In order to determine the effectiveness of oleophobic gaskets, the design team needs to determine what products on the market can be used to give a gasket oleophobic properties, create oleophobic gaskets using these products and nontraditional gasket materials, as well as design and build a test rig which measures the leak rate of a gasket at various temperatures and pressures. Once the design and construction of the project is complete, tests will be performed on oleophobic and standard gaskets using the test rig and results will be compared to determine the effectiveness. The test rig must be capable of testing oils that range from 22 to 120° Celsius and inducing a pressure on the oil ranging from 0 to 2.5 psi.



## 2. Project Definition

### 2.1 Background Research

Gaskets materials are used for different applications to prevent leakage of fluids at a joint, typically flanged bolted joints. These gaskets are usually metallic, polymeric, or paper materials, and they are expected to function effectively when subjected to various pressures and temperatures.<sup>1</sup> Gaskets are more likely to fail under adverse conditions, such as at higher pressures, higher temperatures, and poor flange surface conditions. The failure of gaskets can also be dependent on the size of the gasket, as larger gaskets have more potential leak paths. This project team is saddled with the task of determining if the use of an oleophobic gasket would prevent/reduce the effect of a gasket failure, while still having the reliability and durability of standard gaskets. The gasket performance will be tested with the use of a test rig, which is the second responsibility of the team.



Figure 1. Nonoleophobic (left) vs. oleophobic (right)

To have oleophobic properties means a material will have a tendency to repel oil from its surface which can be seen in Figure 1.<sup>2</sup> Oleophobicity is reliant upon the concept of surface energy, which is the excess energy on the surface of a bulk material.<sup>3</sup> Therefore, oleophobic material must have a lower surface energy than oil.

This project is a first for FAMU/FSU senior design, meaning it is not a continuation of a previous project. Also, Cummins Inc. has not performed research or tests of their own, meaning that this senior design team is the first group to work on this project. Previous works related to this project involving oleophobic coatings are found on various items such as phones and clothing. Additionally, oleophobic impregnators are used as a tile and grout sealer. These sealants are not intended to prevent oil leakage. All of the aforementioned oleophobic solutions aim to simply repel oil from a surface, allowing the surface

to maintain a clean finish. Currently, the design team has found no existing work involving the use of oleophobic sealing solutions on gaskets.

A related piece of literature to this project is the article *Fabrication of Super-hydrophobicity and Oleophobic Sol-gel Nanocomposite Coating*.<sup>4</sup> This article discusses how to lower the surface energy of a material through the application of a fluoropolymer. This article is relevant to the project as fluoropolymers are typically found in oleophobic sealing solutions, confirming the feasibility of on market sealing solutions.

There are four main types of gaskets used on engines to create seals: paper gaskets, FIPG gaskets, molded elastomer gaskets, and rubber coated metal gaskets. Paper gaskets are composed of 90% fibers and 10% elastomeric binder.<sup>1</sup> These gaskets are widely used because of how cost effective the production process is for them; however, they are subject to many failure modes such as weeping oil through the paper and bolt load relaxation. FIPG gaskets are gaskets that are applied to flanges in a liquid state and cure to create a seal. FIPG gaskets rely on adhesion to the flange surface to prevent leakage rather than pressure, as the other gaskets do. Rubber coated metal gaskets are composed of a metal core, which is coated with a thin layer of rubber, typically 25-75  $\mu\text{m}$  thick.<sup>1</sup> Rubber coated gaskets are typically used in high temperature applications. The final type of gasket, molded elastomer gaskets, are gaskets which are composed of elastomers which were molded into a particular shape for usage. An example of a molded elastomer gasket is an o-ring. These gaskets typically display the best sealing characteristics of the four types of gaskets.

## 2.2 Need Statement

Cummins Inc., the largest diesel engine manufacturer in the world, would like to investigate if introducing an oleophobic substance to gaskets will decrease the amount of oil leakage experienced at various joints on their engines. Within the scope of the investigation is to research different types of oleophobic products, the different application procedures for these products, and which materials are compatible with these products. The contact joints that Cummins Inc. is most interested in are larger, low pressure flange joints. Examples of such a joint is the joint between the engine block and the oil pan. In such a joint, the oil is at a low pressure, but there is a large exposed gasket length for potential leaks to occur at. These leaks can lead to excessive

engine wear and possible catastrophic failure. Currently gaskets prevent oil leakage solely through contact pressures between the gasket and the flange surfaces, which create a seal. The purpose of this project is to determine if using an oleophobic gasket would reduce the amount of oil leakage compared to current gaskets used by Cummins Inc.

**Need Statement:**

**“Gaskets used at large joints where the oil is at low pressure leak more oil than desired.”**

## 2.3 Goal Statement and Objectives

**Goal Statement:** “Determine the effectiveness of oleophobic gaskets through the use of a test rig designed by the team.”

Table 1. Project Objectives

<b>Objective Number</b>	<b>Objective</b>
1	Research what causes items to become oleophobic.
2	Create oleophobic gaskets using on market products.
3	Create oleophobic gaskets using non-conventional gasket materials
4	Design and build the test rig to be capable of varying pressure and temperature
5	Test oleophobic gaskets and currently used gaskets for leak rate and compare results

## 3. Design and Analysis

### 3.1 Project Constraints

Multiple constraints associated with this project must be adhered to in order to determine the effectiveness of the gaskets. There are several categories for the constraints, and they are as follows:

#### Components/Gaskets

- An oleophobic gasket must be created using non-conventional gasket materials. This means that any form of rubber may not be used in the creation of this gasket.

#### Time Constraint

- The test rig construction must be completed within the time frame to carry out testing, which should be at least two weeks prior to the project completion date.
- The leak rate test result will be completed by the end of spring 2016 semester.

#### Testing Constraints

- Cummins requires that the design team use two types of standard gaskets as a baseline test to compare to the oleophobic gaskets. These two standard gasket type are paper gaskets and rubber coated metal gaskets.
- Cummins asks that the design team not test at internal pressures greater than 2.5 psi. The reasoning behind this is to accurately simulate the pressure present within an engine and to reduce the risk of injury during testing.

### 3.2 Design Specifications

Measurable design specifications important to this design include test rig dimensions, internal stress bearing capacity of the test rig, flange dimensions, clamping pressure needed for the bolts on the flanges, as well as flange surface roughness. Through preliminary research, some

materials have been considered for the design. For example, the test rig can be made from an aluminum alloy, and the bolts can be made from steel.

Table 2. Design Specifications

<b>Design Specifications</b>	<b>Expected Value</b>
Test Rig Dimensions	Inner Diameter (ID): 55 mm Outer Diameter (OD): Dependent upon analysis results
Test Rig Stress Capacity	Dependent upon analysis. Must withhold maximum pressure of 2.5 psi as set by sponsor.
Flange Dimensions	Inner Diameter (ID): 55 mm Minimum Outer Diameter (OD): 140 mm
Clamping Pressure	Minimum of 0.5 MPa according to Cummins standards. Maximum of 10 MPa according to Cummins standards.
Flange Surface Roughness	Maximum 3.2 microns RA.

### 3.3 Performance Specifications

The gasket will sit between the flanges of the test rig, providing adequate sealing and minimal leak rate during testing, thus simulating an actual bolted joint on an engine. The operational temperature of the test rig will be between 22-120° C with  $\pm 2^\circ$  C accuracy, and the internal oil pressure will range from 0 to 2.5 psi with  $\pm 0.01$  psi accuracy. The pressure sensor must be very precise as it will be used to measure the leak rate, which is expected to be a relatively small value. A very precise pressure sensor, such as a pressure transducer, will provide the necessary resolution. The test rig will be heated through an external source such as an electric hot plate, which will display the external temperature on its digital display. This heating arrangement will induce elevated temperature within the oil, which can be directly measured via a temperature sensor (Resistance Temperature Detector) within the test rig.

### 3.4 Functional Analysis

To ensure the consistency and accuracy with which testing will be conducted, a functional analysis has been conducted.

### 3.4.1 Ideal Gas Law

In order to calculate the leak rate from the test rig, the Ideal Gas Law will be used. The Ideal Gas Law is shown in Equation 1.

$$PV = nRT \quad (1)$$

In Equation 1,  $P$  is the pressure of the gas which in this case is the air,  $V$  is the volume of the air,  $n$  is the number of moles of air,  $R$  is the universal gas constant, and  $T$  is the temperature of the air. During the testing of the gaskets within the test rig, the temperature ( $T$ ) of the air within the test rig will be maintained constant. Also, the number of moles ( $n$ ) of air within the test rig will remain constant since air will not leak out of the test rig. In addition, the value of the gas constant ( $R$ ) remains constant since it is a constant value by definition. Therefore, the entire right side of the Ideal Gas Law in Equation 1 will remain constant throughout the test. As a result of this, the Ideal Gas Law can be reduced to enable the calculation of the final volume of air in the pressure vessel ( $V_2$ ) since the values of the initial internal pressure of the air ( $P_1$ ), the initial volume of air ( $V_1$ ), and the final pressure ( $P_2$ ) are known. The pressure values will be recorded using a pressure transducer, and the initial volume of air will be known based on the known volume of the test rig as well as the volume of oil which was inserted into the test rig. The reduced version of the Ideal Gas Law is shown in Equation 2.

$$P_1V_1 = P_2V_2 \quad (2)$$

Following the calculation of the volume of air in the test rig at the end of the test ( $V_2$ ), the difference between the initial volume of the air and the final volume of air will equal the change in volume of oil within the test rig. This volume, when divided by the total time of the test, will give the oil leak rate. This oil leak rate is a result of the oil which leaked past the tested gasket, thus giving a quantifiable number to the effectiveness of the gasket.

### 3.4.2 Pressure and Bolt Torque Relationship

In order to introduce a performance variable to the testing, the clamp load on the gasket will be varied during testing. Clamping load has a significant impact on the sealing of gaskets, since it is the compression of the gasket which creates the seal. Therefore, by varying the clamp load, the ability of the gasket to prevent leakage in various conditions can be determined. Since the clamp load will be applied through the use of bolts, the relationship between the applied torque ( $T$ )

(measured via a torque wrench) and clamping force ( $F$ ) must be determined. Equation 3 shows the relationship between the applied torque to a bolt and the axial force it applies.<sup>5</sup>

$$T = cdF \quad (3)$$

The nominal major bolt diameter is defined by  $d$ , and the coefficient of friction of the material is shown as the variable  $c$ . For testing, the induced clamping pressure over the gasket will be varied from 0.5 MPa – 10 MPa. The relationship between total bolt force ( $F$ ), gasket area ( $A$ ), and clamping pressure ( $P$ ) is shown in Equation 4. Thus, the team will be able to relate the desired clamping pressure to an applied torque value on the bolts.

$$P = \frac{F}{A} \quad (4)$$

### 3.5 Concept Generation

In order to design and build the most efficient and accurate test rig, the design team generated a total of five concepts. Each concept contained the same base requirements, as explained in the product specifications. All five concepts would be a cylindrical shaped pressure vessel capable of withstanding the 2.5 psi internal pressure induced upon it, and each concept contained two flanges which would compress a flat gasket. In addition to the flanges, each test rig concept contained four bolts which are oriented 90 degrees apart from one another. These bolts could serve two purposes for the test rig concepts: create a clamping load on the flanges, or simply align the two test rig “halves” if some other means of inducing a clamp load is used. If the bolts are used to create the clamping load, then they will also keep the test rig components aligned. Another feature of all five concepts is the elevation of the fasteners (nuts and/or bolts) from the bottom surface of the test rig. The design team had decided upon using a hot plate as the heat source for the test rig; therefore, it was necessary to elevate the fasteners off the bottom surface to prevent the heating of the fasteners directly. If the fasteners were heated directly, it is more likely that there could be a load relaxation in the bolted flange caused by thermal expansion of the bolts.

### 3.5.1 Concept #1

With the goal in mind to create a test rig which can interchange at least one the flange that is in contact with the gasket, the team generated concept #1, which is shown in Figure 2. Concept #1 utilizes removable flanges which slide onto and off of the upper and lower bodies of the test rig, thus allowing the flanges to be changed while maintaining the repeated use of the main components of the test rig, such as any sensors. The upper and lower flanges shown in Figure 2 are removable. The lower body of the test rig is identical to the upper body in terms of geometric measurements, and thus fasteners are elevated off the bottom surface of the test rig as desired.

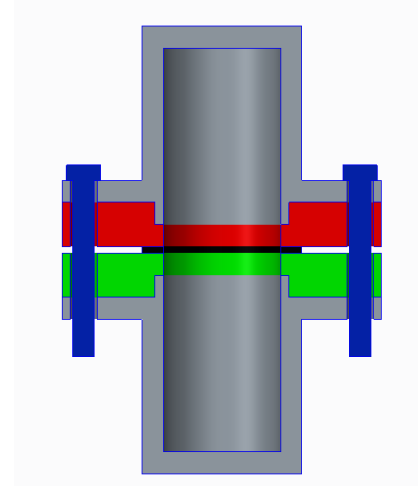

Figure 2. Concept #1 and Concept #2 cross section

### 3.5.2 Concept #2

The second concept the team generated is very similar to concept #1 in appearance, thus Figure 2 is also a good representation of concept #2. The feature which distinguishes concept #2 from concept #1 is the means of adding/removing the removable flanges. Instead of sliding on and off, as in concept #1, the flanges in concept #2 will have internal threading which will allow the flanges to screw onto the test rig body components. Obviously, this will also require that the test rig body components have external threading to create the interface with the flanges. In order to reduce the leak paths which are associated with straight threads, concept #2 utilizes tapered threads which will create an air tight seal between the test rig and the flanges. Therefore, it is anticipated that concept #2 would contain less unwanted leak paths, however lacks the easy of assembly and durability of concept #1.



### 3.5.3 Concept #3

Concept #3 takes a different approach to incorporating a means to interchange at least one flange which is in contact with the gasket. Instead of having removable flanges, concept #3 would instead have several different lower test rig bodies which would be interchanged based on the experimental trial. The lower test rig body would contain the flange that is in contact with the gasket, thus reducing the leak path introduced by having a removable flange. The upper body of the test rig would also have the flange incorporated into it as a solid body, since only one flange needs to be interchangeable based on the sponsor requirements. In order to keep the fasteners elevated off the bottom surface of the test rig, the lower body pieces will have a bowl shape. Thus, the bottom of the lower body remains as the lowest surface of the test rig.

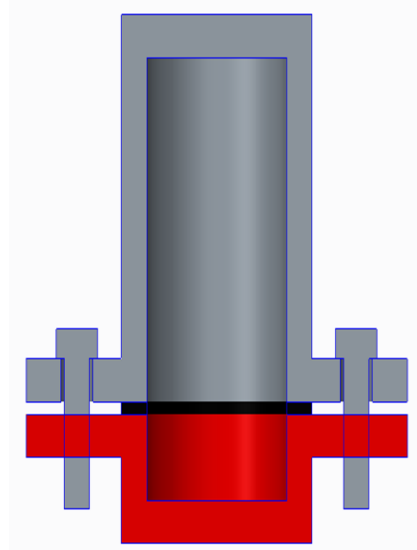

Figure 3. Concept #3 cross section

### 3.5.4 Concept #4

Concept #4 again utilized the idea of having several different test rig lower bodies rather than removable flanges. However, concept #4 took a different approach to keeping the fasteners off the lowest surface of the test rig. The bowl-shaped test rig lower body in concept #3 requires fabrication in order to create the bowl. As an attempt to reduce the amount of fabrication, the team set out on creating a concept which utilized a flat plate as the lower body/flange. Therefore, as shown in Figure 4, concept #4 uses a flat plate instead of a bowl shaped lower body. In order to prevent the fasteners from being the lowest surface on the test rig, the bottom plate would be threaded for the bolts.

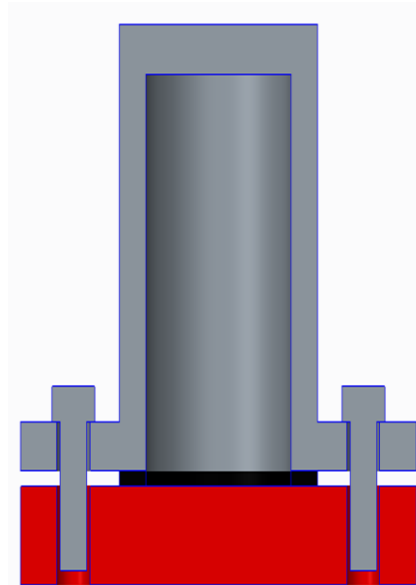

Figure 4. Concept #4 cross section

By threading the lower body directly, as long as the bolts used were not long enough to protrude from the lower body, the

bolt would not contact the heat source. However, this will require that the lower body be thicker than otherwise necessary. Also, the possibility of thermal expansion of the bolt is still a risk since the bolt is in direct contact with the threaded component on the heat source (the lower body). Therefore, concept #4 would be easier to manufacture, but may not offer the best performance in terms of functionality.

### 3.5.5 Concept #5

With concept #5, the design team wanted to use a flat plate for the lower body/flange, but offer a different method to prevent the fasteners from being the lowest surface on the test rig. As it can be seen in Figure 5, concept #5 uses a thinner flat plate for the lower body/flange. This plate

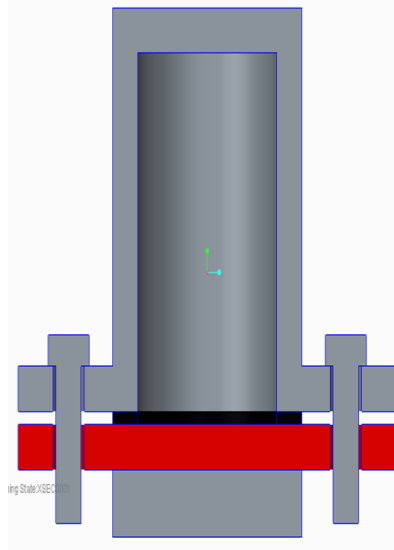

Figure 5. Concept #5 cross section

would be changed and replaced with a different plate based on the experimental trial being performed. Nuts will be used to secure the bolts in concept #5, therefore the lower body/flange will not be threaded as it is in concept #4. In order to prevent the fasteners from being the lowest surface of the test rig, an additional spacer will be placed below the lower body/flange. This spacer will be of the same material as the rest of the test rig, therefore will have the same thermal conductivity as the lower body/flange. The spacer would not be permanently secured to the lower body/flange, therefore the same spacer could be used for every lower body/flange used in testing. This spacer would sit directly on the heat source, thus elevating the

fasteners. Concept #5 allows for fast and simple fabrication, as well as preventing the thermal expansion of the fasteners.

## 3.6 Evaluation of Concepts

The technique chosen to evaluate these five concepts was in the form of a Pugh matrix (Figure 6). On the left hand side, there are different categories such as number of leak paths, ease of assembly, and machinability assigned to each concept. These categories are then assigned a weighting factor which are dependent upon their importance. The weighting factors of all of the categories sum up to one. Therefore, the categories of greater importance are assigned higher

weighting values. For instance, number of leak paths is weighted the highest at 0.25 because this is the main method of determining the effectiveness of oleophobic gaskets, whereas cost is weighted the lowest at 0.05 since additional funding can be obtained if needed. This means the team is more concerned with a test rig that will not confound the results with potential leak paths than with the cost of manufacturing it.

This Pugh matrix allows for evaluation of different concepts in relation to a baseline concept. The first concept was set as the baseline with zeroes in all of the categories. All of the other concepts were evaluated in relation to whether it was an improvement or degradation of concept one. A score of one or two denotes improvement, while negative one or negative two denotes degradation. A score of zero means neither improvement nor degradation.

All team members participated by completing their own Pugh matrix and the results were averaged together as shown in Figure 6 below. The results of the Pugh matrix identified concept five as the winning one. This concept won due to the very high scores in categories: number of leak paths, machinability, and cost. Concept five really simplifies the bottom flange down to a single sheet of material that does not require embedded threading or extra material as a buffer for the bolt lengths.

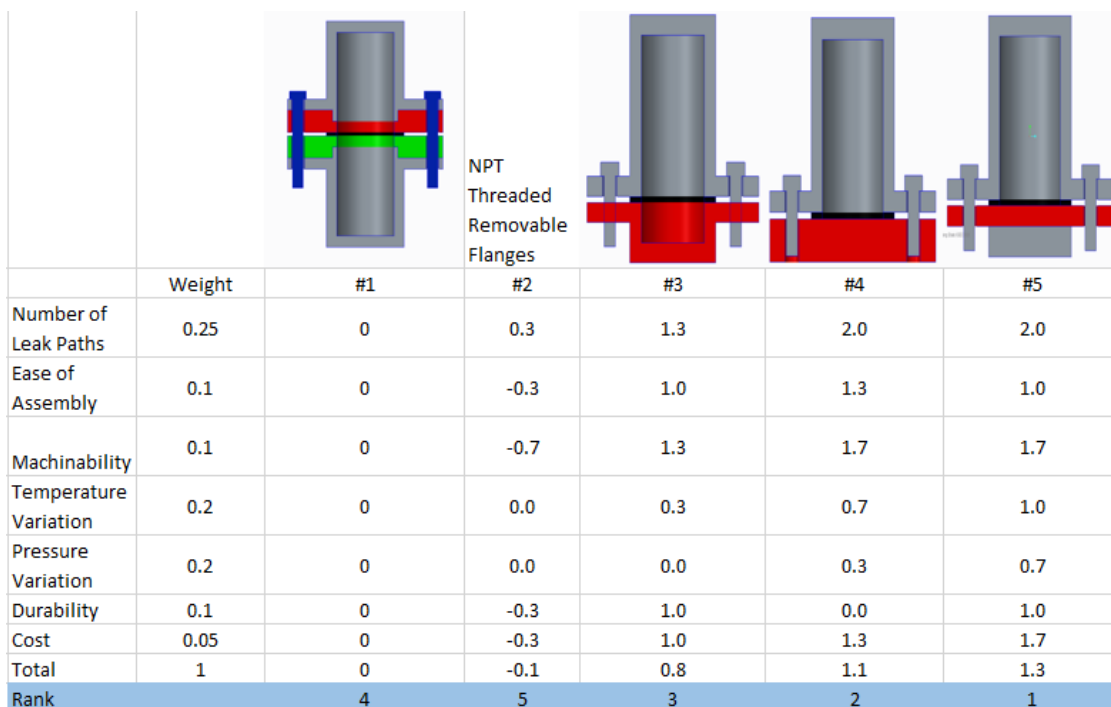

Figure 6. Pugh Decision Matrix for Test Rig Decision

### 3.7 Detailed Evaluation of Concept Five

After selecting Concept #5 as the winning concept for the test rig, the design team began to lay out where the hardware items would be located. Figure 7 shows a CAD model of the more detailed layout of the test rig. The hardware includes items such as the pressure transducer, air inlet valve, etc. The layout of the hardware in figure 7 is dependent on bolts being used to create a clamping pressure on the gasket. As shown in figure 7, all of the hardware items are located on the upper body of the test rig. This allows for the hardware to only be required to be installed once. If the hardware were installed in the lower flange, then the hardware items would need to be removed and re-installed each time the lower flange was swapped for testing conditions. Not only does having all the hardware located on the upper body make the testing process more time efficient, but it also minimizes the likelihood of a leak occurring at one of the hardware interfaces. All of the hardware has NPT threading, and NPT threading creates a tight seal by causing yielding in the materials when tightened. Therefore, NPT threads are not durable to repeated installation and removal.

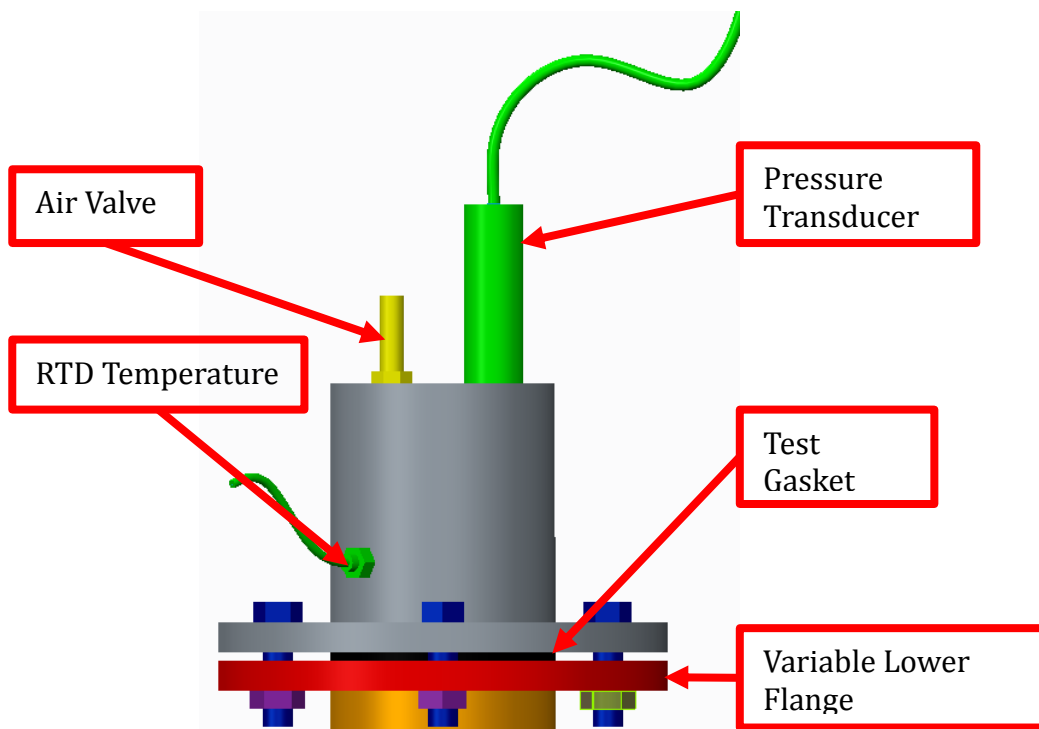

Figure 7. CAD model of test rig Concept #5 with the additional hardware components required for testing purposes

As shown in figure 7, the pressure transducer and the air inlet valve are located on the top surface of the test rig. This allows both of these hardware components to be open to the air cavity which is present above the oil level. Figure 8 shows the approximate oil level location for the test rig. With both of these items being exposed to the air, it minimizes the likelihood of oil entering either of these components and fouling them. The pressure transducer needs to be exposed to the air in order to measure the air pressure, which is used in the Ideal Gas Law calculations. The RTD sensor is located below the oil level, as shown in figure 8. This allows for the oil temperature to be measured rather than the air temperature. The purpose of measuring the oil temperature is to know the state of the oil during the test. For example, the oil will become less viscous at elevated temperatures, and therefore more likely to leak.

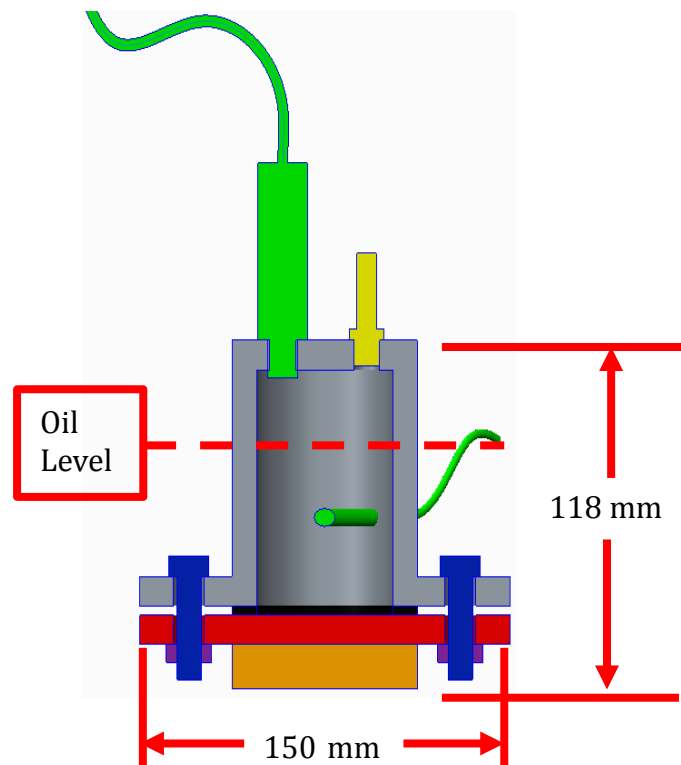

Figure 8. Cross sectional view of the test rig, which shows the oil level relative to the hardware components

## 4. Methodology

The first major objective of the project that was completed was to determine what options are currently on market to make gaskets oleophobic. In order to determine which options are available, the team has researched the market using the internet, and by contacting suppliers to get professional feedback. Once current market items are determined, they will be evaluated by the team for practicality, performance, and environmental applications. The team will then select the suitable method(s) to make an oleophobic gasket and procure these “on market” products. Using these products, the team will create the oleophobic gaskets, which will be leak rate tested.

The other major objective of the project is to design and build a test rig which will be capable of measuring the leak rate of gaskets. The team has held discussions with the sponsor to determine if there are any company standards for test purposes, such as leak path length, standard diameters, pressure ranges, and availability of current gaskets used by the sponsor. Using this information, the required size of the system was determined and designing began on the test rig. The physical designing of the testing rig will utilize CAD software for visual purposes as well as part drawings, and any mathematical calculations will be done using Mathcad in order to ensure accuracy.

Testing will be performed on the oleophobic gaskets using the test rig built by the team. The leak rate test results for the oleophobic gaskets will be compared to standard gaskets, which will allow the team to draw conclusions on the effectiveness of an oleophobic gasket. The tests will be performed using different oil pressures and temperatures within the test rig, which will provide more data to compare with standard gaskets.

In order to prevent exceeding the \$2,000 budget, price will be weighed in every decision to make sure the team makes the best decision between performance and costs. Items which will be used in the building of the test rig will be quoted to ensure the lowest possible price was obtained, thus using the team’s budget efficiently. In order to keep the project on schedule, a Gantt chart was created (Appendix A). The Gantt chart will continuously be updated by the team as the project advances, allowing for proper planning if the project deviates from the original schedule.

## 4.1 Resource Allocation

The background research phase was completed as an entire team, where individual team members were assigned small topics to research and share with the team. Heather Davidson and Norris McMahan researched the science behind oleophobicity, while Daniel Elliott researched common causes for gasket failures. Erik Spilling researched into what types of oleophobic spray coatings are currently available on market, and David Dawson researched if a product could be used to impregnate a material to create oleophobic characteristics for the material. Further research is being performed by the team, including researching temperature and pressure measurement devices, machining practices, pressure vessel minimum thickness criteria, bolt load and its effect on clamping force, and continued research into oleophobic solutions. The entire team contributed to the background research phase of the project.

The senior design team decided to divide into sub-teams so that the necessary effort could be applied to both the oleophobic gasket aspect of the project, as well as the design and fabrication of the test rig, simultaneously.

- Gasket Team:
  - This sub team consists of Norris McMahan, David Dawson, and Aruoture Egoh. The gasket team is responsible for continued research into what process and products can be used to create an oleophobic gasket. Once the gasket team identifies the available oleophobic solutions on market, they are responsible for selecting the solutions for the team to purchase and test. The gasket team will also be responsible for creating the oleophobic gaskets, whether that involves spraying an oleophobic solution onto existing gaskets or some other means that the team identifies. The gasket team is also responsible for providing the gasket needs to Cummins Inc., so that Cummins Inc. can provide the necessary gaskets for testing.
- Test Rig Design Team:
  - The test rig design team consists of Erik Spilling, Heather Davidson, and Daniel Elliott. The test rig team is responsible for generating concepts for the test rig, performing the calculations to determine the design details for the test rig (such as wall thickness, bolt loads, etc.), creating the CAD models and drawings, material

selection, and creating a list of raw material quantities which will need to be purchased. The test rig design team will work as a group to complete all of the aforementioned tasks, since the team believes a group effort will yield the best design.

Parts ordering will need to be done as the sub teams reach final designs. David Dawson will be responsible for maintaining the team budget, and thus will also be responsible for the parts ordering. The sub teams will provide David with a list of the desired raw materials, and David will check to make sure that the parts/materials can be purchased within the team's budget, and make the purchases.

The budget given for this project was \$2,000 through Aero Propulsion, Mechatronics and Energy Center (AME). This budget will be used to acquire all of the materials that will be needed for application and testing for determining the effectiveness of oleophobic gaskets. The values shown are the maximum estimated values for each item needed and were calculated by researching into potential products. As seen in Table 3, even after calculating for the maximum prices, the project will still be under the allotted budget of \$2,000.

Table 3. Budget

<b>Item</b>	<b>Maximum Estimated Amount</b>
Test Rig Raw Materials	\$100.00
Test Rig Sensors	\$1,000.00
Gasket Materials	\$150.00
Oleophobic Solutions	\$400.00
Oleophobic Material	\$200.00
Oils Used for Testing	\$50.00
<b>Total</b>	<b>\$1,900.00</b>

Fabrication will be performed by the entire team. The raw materials for the test rig will be machined by the COE machine shop, but the assembly of the test rig will be done by the entire team.



The testing process will be performed by the entire team as well. Since a large number of tests are expected to be performed, the team plans to do one set of tests as a group. These initial tests will be done together to create a step by step testing process that the entire group understands. Then, testing will be broken into smaller groups so that the entire team does not need to be present for every single test run. The smaller groups will be groups of two or three.

The team web page was designed by Heather Davidson. The team utilized the advice and resources provided by Ryan Kopinsky in order to best design the team web page.

## 4.2 Schedule/Deliverables

A schedule of the team's project plan for the rest of the fall semester can be found in a Gantt chart (Appendix A). This Gantt chart encompasses a work breakdown structure (WBS) which details who is responsible for each task. The arrows in the Gantt chart show the prerequisite relationship between two tasks. Additionally, critical tasks can be identified by their duration in the time schedule. For example, part acquisition is a very critical task as it is expected to take the longest, and the project cannot precede without the completion of it.

## 4.3 House of Quality

After first speaking with the sponsor and defining their requirements, a diagram known as a House of Quality (HOQ) was constructed (Figure 9). This diagram relates the sponsor's requirements with various engineering characteristics. For instance, there is a strong correlation between the requirement of comparable performance and the characteristic gasket leak rate. Additionally, the diagram also depicts the relationship between any two engineering characteristics. This is illustrated in the top triangle of the "house." There is a strong positive correlation between the cost and the test rig pressure. To simulate higher pressures in the test rig a more complex design is required, and this will require money thus increasing the cost. Through this diagram, the number one engineering characteristic identified was the gasket leak rate.

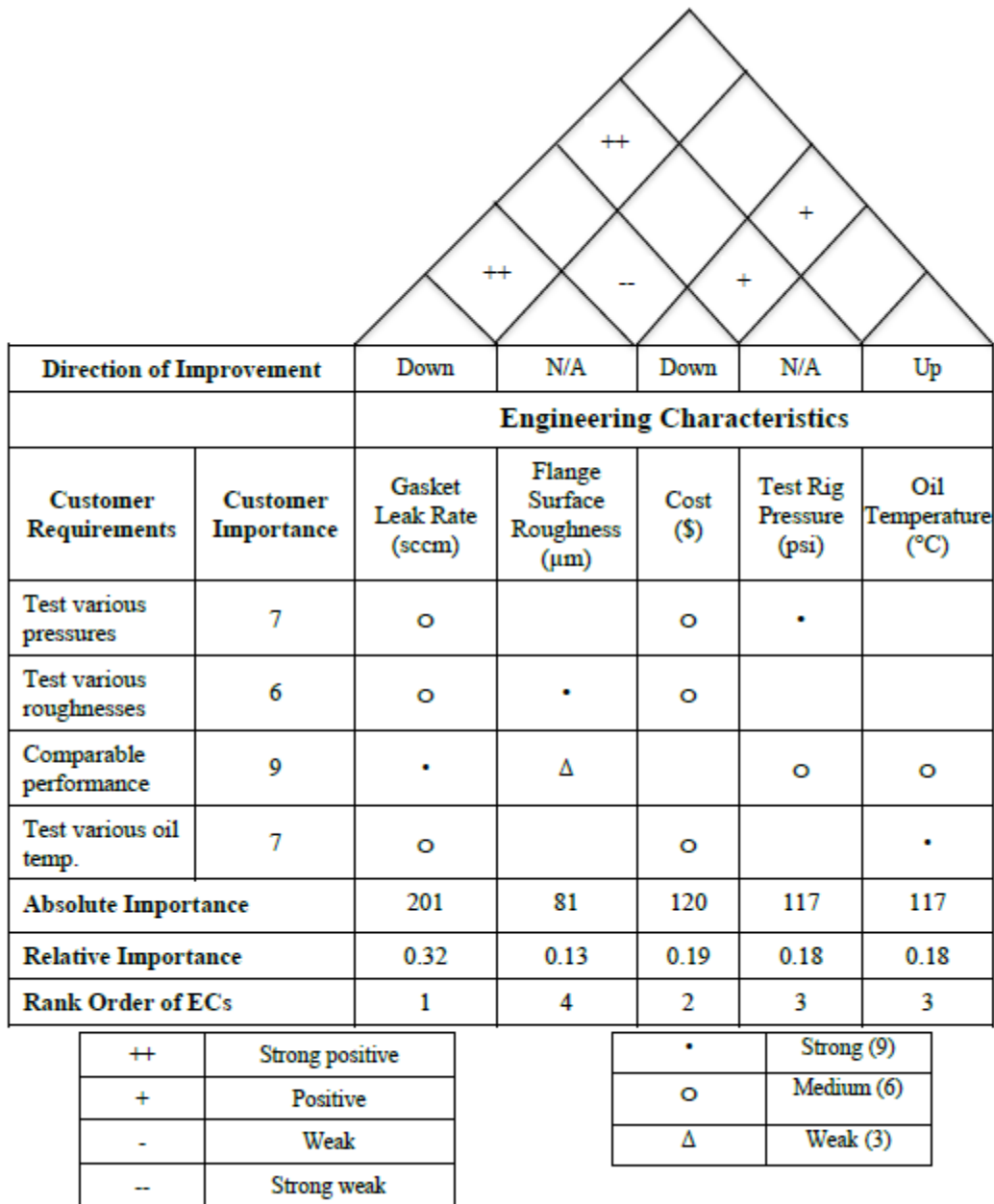

Figure 9. Constructed HOQ using sponsor information

### 4.4 Risk Assessment

After analyzing the risks that could occur during this project, a new set of testing procedures was created focusing on safety. When creating oleophobic gaskets, the team will wear gloves, long-sleeved shirts, long pants, closed toe shoes, eye protection, and masks at all times. The test rig

will be built by the FAMU/FSU machine shop safely and efficiently. When conducting the leak tests, the test rig will be placed into a plastic container. Anyone handling or monitoring a short distance away from the test rig will have to wearing heavy clothing which doesn't reveal skin, closed toe shoes, a mask with eye and face protection, and heavy gloves.

## 5. Results

Though the test rig has not been constructed yet, the team has been able to perform some calculations and simulations in order to provide proof of concept for the test rig. The team investigated if the selected bolts would be able to withstand the required axial force in order to obtain the desired clamping pressure, and also analyzed the gap between the bolts to ensure that the use of four bolts provides an accurate sealing effect for the gasket. In addition, the hardware for the test rig was selected based on design specifications.

### 5.1 Bolt Load Analysis

As previously stated, the test rig is currently designed to be clamped using four bolts. The reason that four bolts were chosen for the design is that using four bolts around the circular gasket is an accurate method to simulate an actual engine seal. If only two bolts were used, less of the bolt load would be transferred through the gasket interface, thus not sealing properly. When designing bolted joints on engines, it is typical to place the bolts along the gasket path. Therefore, using four bolts is a better solution than using two or three bolts, because the bolts follow the gasket path more closely.

In order to determine how much torque needs to be applied to the bolts to achieve the desired clamping pressure, the team performed calculations utilizing Equations 3 and 4. Appendix B shows the calculations performed for a clamping pressure of 10 MPa. For the analysis, M8 bolts were chosen for the design. M8 class 5.8 bolts can provide a maximum axial force of 10.4 kN when torqued to a maximum torque of 16.7 N\*m.<sup>6</sup> As shown in Appendix B, in order to achieve a clamping load of 10 MPa, each bolt will need to provide an axial force of 5.1 kN, which is associated with a tightening torque of 8.168 N\*m. Therefore, the required force and torque required to achieve the 10 MPa clamping pressure are well within the maximum values for the selected bolt type. Using this same calculation method, the team is able to calculate the required tightening torque for the bolts for any desired clamping pressure.

## 5.2 Pressure Distribution

In order to test that the use of four bolts would cause the clamping pressure on the gasket to not dip below the desired pressure, a simulation was created within Creo Parametric 2.0 to analyze

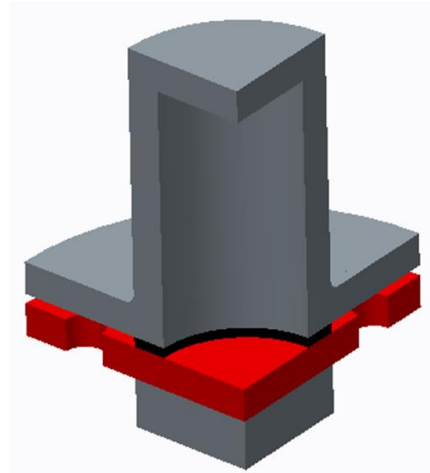

Figure 10. One-quarter of the test rig, which was used for analysis

the contact pressure on the gasket face. In order to improve the “run time” of the analysis, the test rig was divided into four pieces. Analysis was done for one-quarter of the test rig, with the bolts being located at the cut interfaces. Figure 10 displays the CAD model used in the analysis. During the simulations, the bolt load which was applied was equal to the axial force found during the torque calculations for desired pressures. For example, for the desired clamping pressure of 10 MPa, the applied axial forces in the analysis was 5.1 kN.

Figure 11 displays the results of the analysis for a desired clamping load of 10 MPa. The results of the analysis shows that between the bolts, there is no portion of the gasket which will experience less than 10 MPa of pressure all the way across the gasket face. Based on this result, the use of four bolts was confirmed to be a suitable amount of bolts for the design.

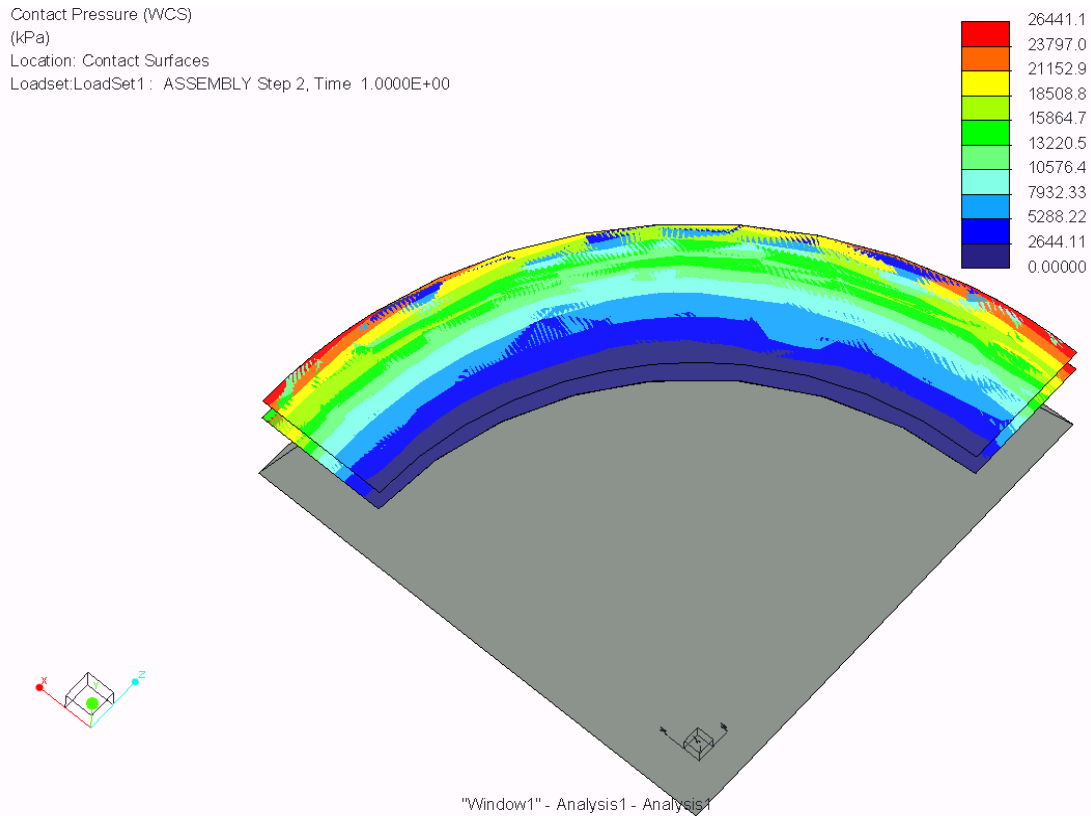

Figure 11. Gasket clamping pressure distribution based on analysis results

## 5.3 Hardware Selection

As shown in figure 7, there are multiple pieces of hardware being utilized in this test rig. In order to select the hardware with a correct resolution, a range of detection and an accuracy must be targeted. As stated previously, the temperature sensor will be reading the oil temperature and is not used in later calculations; therefore, its accuracy is not as important as the accuracy of the

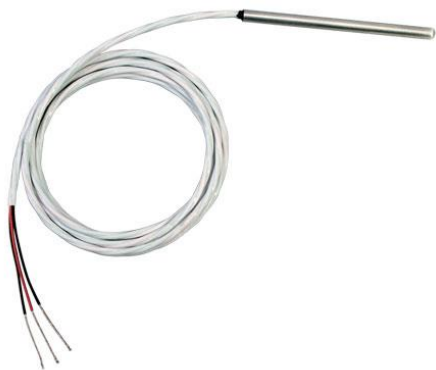

Figure 12. Short RTD probe<sup>7</sup>

pressure which is used in future calculations. The temperature sensor must be able to read the range between 22-120° C with  $\pm 2^\circ$  C accuracy. This accuracy was selected by the team as appropriate for the variable. Using this information, an RTD (Omega PR-20 series), seen in Figure 12, was chosen as the best fit and most inexpensive sensor that meets the requirements. This RTD is smaller than a typical laboratory RTD as it must fit inside of the test rig

fully submerged in the oil. It will be fitted into the side of the test rig using a compression fitting.

The pressure sensor is much more important to the experiment and is required to read a range between 0-2.5 psi with  $\pm 0.01$  psi accuracy.

Additionally, it must function at the elevated temperatures mentioned above. Given these requirements, a pressure transducer (Omega PX409-005GV) was chosen as the best fit, which can be seen in figure 13. This pressure transducer is a gage sensor with an amplified output of 0-5 V which will be read to the DAQ (Data Acquisition) system set up in the laboratory. It can measure up



Figure 13. Pressure transducer<sup>8</sup>

to 5 psi with an accuracy of 0.05% which falls in the range of the accuracy required.

The other two pieces of hardware on the test rig include the air inlet valve and the oil inlet valve. The air inlet valve will be a very basic stem (Figure 14) that can be fitted with a tap connected to



Figure 14. Air Valve Stem<sup>9</sup>

compressed air which will pressurize the air cavity above the oil. This valve stem can be imagined as the air valve stem on a traditional bicycle tire. The air will be pumped in and can be released by pressing on the

center of the valve stem. The oil inlet valve will be a ball valve which creates an air-tight seal. To fill the test rig with oil, the ball valve will be opened by turning the valve handle, and a funnel will be used to pass the oil through it. During testing, the valve will be sealed shut which will eliminate the possibility of oil and air leaking past the valve. After testing, the valve can be opened and the test rig can be drained. The team has selected an appropriate ball valve to use for the test rig. It will use a compact high pressure ball valve, which has a total length of 1.875 inches, and a male thread of 1/8 NPT. This small size allows for the ball valve to claim minimal space on the test rig, thus leaving room for the other hardware.



Figure 15. Ball Valve<sup>10</sup>

## 6. Conclusion

The purpose of this project is to determine if the development and implementation of oleophobic gaskets would be useful in practical applications. This will be achieved by researching modern oleophobic gasket solutions and selecting the best solutions to test in an oil leak rate test rig, which will be constructed by the team. These oleophobic gaskets will be compared to baseline model tests using engine oil at a pressure of 2.5 psi. The goal of the test rig is to be capable of operating with oil temperatures of 22 to 120 °C. Tests will be performed with a gasket at variable clamping pressure to change the compression on the gasket. The results from this experiment will provide a better understanding if oleophobic gasket solutions are effective in terms of practicality, performance, and applicability.

The gasket team is still working on oleophobic solutions for traditional gaskets as well as nonconventional oleophobic gaskets. The team will continue to hold informal and formal bi-weekly meetings to provide regular updates on the progress of the project. A schedule in the form of a Gantt chart has been put in place to allow the team to have a visualized timeline of major and minor tasks throughout the completion of this project.

In the time before the next deliverable, the team will finalize the CAD drawings to include the final locations of the pressure transducer, oil inlet valve, air inlet valve and temperature sensor on the test rig, as well as the material type of each piece of the test rig. Our House of Quality determined that our number one engineering characteristic to design for is the ability to measure the leak rate so that must be at the forefront of the design criteria. The team will also work with suppliers to negotiate correct quantity and price packaging for gaskets and nontraditional gasket material that can be coated in an oleophobic solution. The goal for the next deliverable is to have the nonconventional gasket material and oleophobic solutions purchased, have the test rig specifications and material selection finalized, and the raw materials for the test rig purchased.



## References

- [1] "Gasket Materials and Selection." Gasket Materials and Selection. N.p., n.d. Web. 25 Sept. 2015.
- [2] "Spigen." Galaxy S4 Screen Protector GLAS.t NANO SLIM Premium Tempered Glass-Oleophobic Coating. N.p., n.d. Web. 25 Sept. 2015.
- [3] "Surface Energy and Wetting." Surface Energy and Wetting. N.p., n.d. Web. 25 Sept. 2015.
- [4] "Fabrication of Superhydrophobic and Oleophobic Sol-gel Nanocomposite Coating." Fabrication of Superhydrophobic and Oleophobic Sol-gel Nanocomposite Coating. N.p., n.d. Web. 25 Sept. 2015.
- [5] "Torque." Engineers Edge. N.p., n.d. Web. 28 Oct. 2015
- [6] "Tightening Torque." *Field Guide to Optomechanical Design and Analysis* (2012): n. pag. Web.
- [7] "Short RTD Probe." *Short RTD Probe*. Web. 30 Oct. 2015.
- [8] "PX409 Series High Accuracy Pressure Transducers Now with 0.05% Accuracy and 0.03% Linearity Options." *High Accuracy Pressure Transducers*. Web. 30 Oct. 2015.
- [9] "Valve, Air Tank Filler." *Cdi Control Devices TV12*. N.p., n.d. Web. 30 Oct. 2015.
- [10] "McMaster-Carr." *McMaster-Carr*. N.p., n.d. Web. 30 Oct. 2015.

# Appendix A

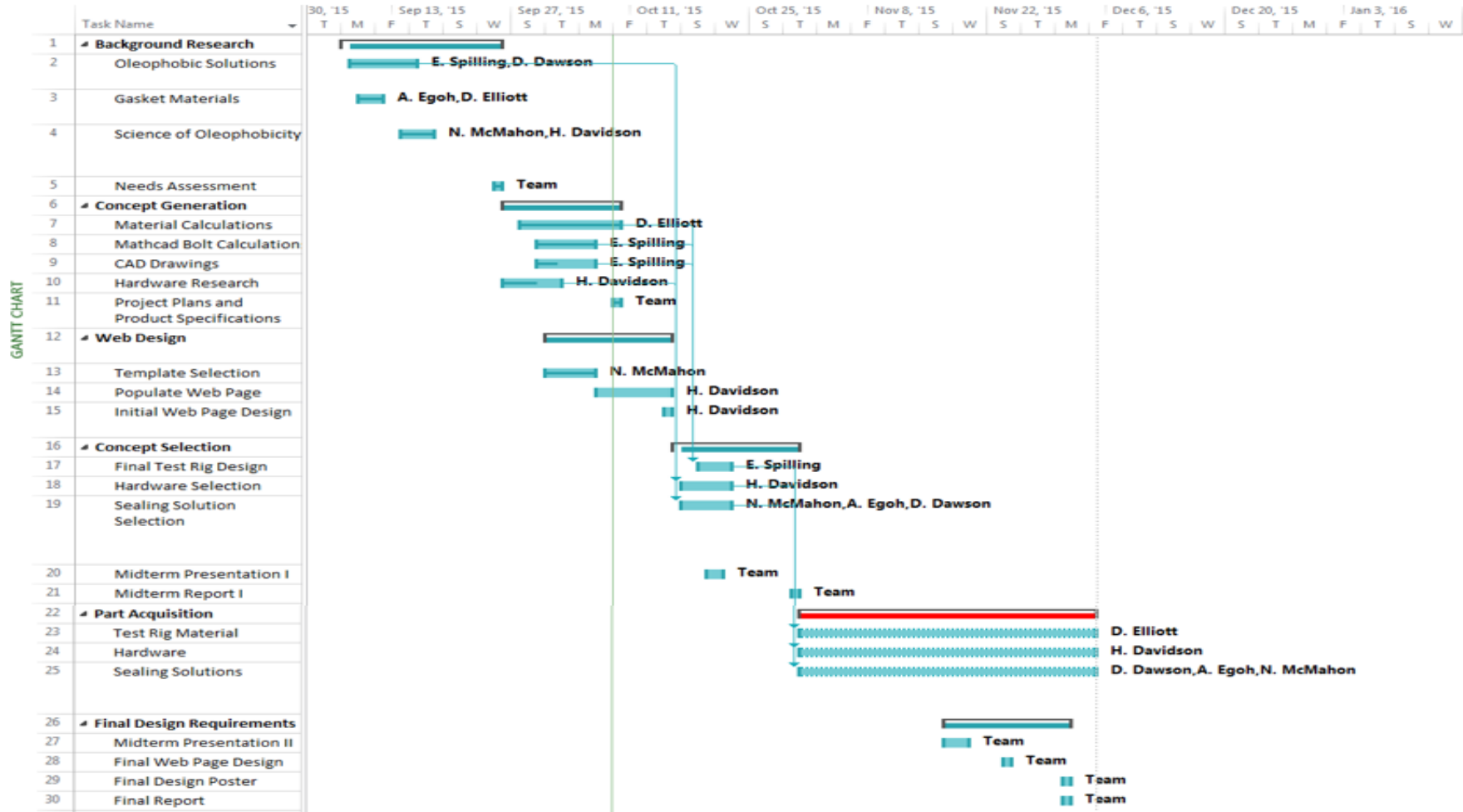

Gantt chart displaying the projected schedule for this semester

## Appendix B

### Bolt Torque Calculations

The nominal diameter of the bolt

$$D_{\text{nom}} := 8\text{mm}$$

Number of Bolts

$$NB := 4$$

Input Gasket Parameters:

$$D_{\text{inner}} := 55\text{mm}$$

$$D_{\text{outer}} := 75\text{mm}$$

Sealing pressure on Gasket:

$$P_{\text{max}} := 10\text{MPa}$$

Determine gasket area:

$$A_{\text{outer}} := \frac{\pi \cdot D_{\text{outer}}^2}{4} = 4.418 \times 10^{-3} \text{ m}^2$$

$$A_{\text{inner}} := \frac{\pi \cdot D_{\text{inner}}^2}{4} = 2.376 \times 10^{-3} \text{ m}^2$$

$$A_{\text{gasket}} := A_{\text{outer}} - A_{\text{inner}} = 2.042 \times 10^{-3} \text{ m}^2$$

The total force required to induce the desired pressure;

$$F_{\text{tot}} := P_{\text{max}} \cdot A_{\text{gasket}}$$

$$F_{\text{tot}} = 20.42 \cdot \text{kN}$$

Force required by each bolt for 4 bolt design

$$F_{\text{ind}} := \frac{F_{\text{tot}}}{NB}$$

$$F_{\text{ind}} = 5.105 \cdot \text{kN} \quad \text{force per bolt}$$

The torque coefficient K

$$K := 0.2 \quad \text{http://euler9.tripod.com/fasteners/preload.html}$$

Finding the required torque

$$T_{\text{needed}} := F_{\text{ind}} \cdot K \cdot D_{\text{nom}}$$

$$T_{\text{needed}} = 8.168 \cdot \text{N} \cdot \text{m}$$

# Biography

## **Erik Spilling: Project Leader**

Erik is a Florida State University Mechanical Engineering student from Saint Augustine, Florida. Erik has completed three internships at Cummins Inc., with two of those internships having been spent in High Horse Power Design Engineering. After graduation, Erik will join Cummins Inc. full time as a High Horse Power Design Engineer.

## **Heather Davidson: Lead ME and Web Designer**

Heather is a Florida State University Mechanical Engineering student graduating in May of 2016. Heather was born in Deland, Florida. She has completed two summer internships with ExxonMobil at an oil refinery in Torrance, California. After graduation, she hopes to join industry outside the state of Florida.

## **David Dawson: Financial Advisor**

David is a Florida State University mechanical engineering student with a focus on Thermal Fluids and Energy. David was born in South Africa and raised in Jacksonville, Florida. Following graduation, David plans to pursue a job in either energy satiability or work for the armed forces as a mechanical engineering officer.

## **Aruoture Egoh: Lead Materials Engineer**

Aruoture is an exchange student of Florida Agricultural and Mechanical University from Federal University of Technology, Akure, Ondo state, Nigeria. He plans to complete his bachelor's degree in Materials Engineering, attend graduate school to pursue a master's degree and PhD in materials engineering focusing on Polymeric Materials.

## **Daniel Elliott: Research Coordinator**

Daniel is a Senior Mechanical Engineering student with a minor in Psychology and a mixed focus in Materials and Energy Systems. After graduation, he plans to move to Austin, Texas as his first step in his professional career and in order to be closer to his family.

## **Norris McMahon: Chronicler**

Norris is a student at Florida State University originally from Pensacola, Florida. His area of focus is Mechanics & Materials. He has experienced an internship with Blattner Energy Inc. Following graduation, Norris plans to pursue a Masters in Sports Engineering and would like to end up in the Research and Development of sports products field.