

TEAM 18 – PENETROMETER

Interim Design Report



Carren Brown¹, Peter Hettmann², Sean Kane³, Natalie Marini⁴, Mitchell Robinson⁵, Maritza Whittaker⁶

*Mechanical and Electrical Engineering Departments
FAMU-FSU College of Engineering
2525 Pottsdamer Street
Tallahassee, Florida United States 32310-6046*

¹ME, carren1.brown@fam.u.edu

²ME, pmh10@my.fsu.edu

³EE, srk10e@my.fsu.edu

⁴ME, nrm10d@my.fsu.edu

⁵EE, mwr10c@my.fsu.edu

⁶ME, mnw11b@my.fsu.edu

Due Monday, December 8, 2014

Mr. Mike Russo and the National Park Service: Project Sponsor

Dr. Chiang Shih: Project Mentor/Advisor

Dr. Scott Helzer: ME Project Coordinator/Instructor

Dr. Nikhil Gupta: ME Project Co-Mentor

Dr. Michael Frank: EE Project Coordinator/Instructor

TABLE OF CONTENTS

Group Member Information..... v

Acknowledgement vi

Abstract..... vii

1 Introduction..... 1

2 Project Definition 2

2.1 Background Research 2

2.2 Need Statement 3

2.3 Goal Statement and Objectives 3

2.4 Project Constraints 4

3 Design and Analysis 5

3.1 Functional Analysis 5

3.2 Design Concepts 8

3.3 Design Matrix Criteria 11

3.3.1 Evaluation of Designs 11

3.3.2 Selection of Optimum Designs 12

4 Risk and Reliability..... 13

5 Detailed Design and Design for Manufacturing..... 14

6 Future Plans for Prototyping and Others..... 15

7 Procurement 16

7.1 Procurement and Budget Analysis..... 16

8 Communications 17

9 Methodology 18

10 Schedule 19

10.1 Resource Allocation 19

11 Conclusion 21

12 References..... 22

13 Appendix..... 23

TABLE OF FIGURES

Figure 1. Standardized Penetrometer Design..... 2

Figure 2. Electric Components of the Penetrometer Tip 3

Figure 3. Wheatstone Bridge Configuration. 5

Figure 4. Force Displacement 5

Figure 5. Strain Gauge Circuit. 6

Figure 6. Load Cell Configuration..... 6

Figure 7. Strain Gauge Loading Displacement..... 6

Figure 8. Wireless DAQ Specifications..... 7

Figure 9. Wireless DAQ. 7

Figure 10. Laser Range Finder..... 7

Figure 11. Texas Instruments Voltage Regulator. 8

Figure 12. Mechanical Design A 8

Figure 13. Mechanical Designs C & D..... 9

Figure 14. Electrical Block Diagram 10

Figure 15. Gantt Chart 23

TABLE OF TABLES

Table 1. Design Decision Matrix.....	11
Table 2. Electrical Components Procurement	16
Table 3. Mechanical Components Procurement.....	16
Table 4. Assigned Task List.....	20

Group Member Information

Carren Brown is the Team Ambassador. She is an ME student at FAMU, expecting to graduate with a specialty in Mechanics and Materials. She has completed two summer internships at Florida Power & Light and Colgate-Palmolive. She plans to earn a Master's degree in Engineering Management, and then begin a career in manufacturing.

Peter Hettmann is the team's Treasurer. He is an ME student at FSU, expecting to graduate with a specialty in Dynamics and Mechatronic Design. He has completed two summer internships at Siemens Energy and at Senninger Irrigation. After graduation, he plans to pursue higher education in Computer Science/Engineering with a career in robotics.

Sean Kane is the team's Lead EE. He is an EE student at FSU. He currently holds a part time internship with RCC Consultants, Inc., who is contracted with the Florida Department of Transportation (FDOT) to work on the public safety communication system. He plans to stay in Tallahassee, FL after he graduates to continue work with the FDOT.

Natalie Marini is the Team Leader. She is an ME student at FSU, expecting to graduate with a specialty in Thermal Fluid Sciences. She has previously completed three summer internships at Siemens Energy, and plans on continuing work in the power industry when she graduates.

Mitchell is an EE student at FSU, expecting to graduate in May of 2015. He plans on using his degree to work in the power industry and is specializing in power generation. Mitchell intends on being part of the collaborative effort in design the smart grid in order to meet higher energy efficiency.

Maritza Whittaker is the Team Secretary and Webmaster. She is an ME student at FSU. She has previously completed two summer internships at exp, Inc. and at Oceaneering Entertainment Systems in Orlando, FL. She hopes to pursue a career in the entertainment industry after graduation.

Acknowledgement

The 2014-2015 Penetrometer group would like to thank the following people for contributing their knowledge, expertise and support to the project:

- Dr. Frank for sharing his knowledge and expertise with the electrical aspect of the design.
- Dr. Shih for frequently providing important assessment of the overall design of the project.
- Dr. Helzer for providing guidance to the mechanical aspect of the design.
- Dr. Gupta for providing expertise to ensure the compatibility between the electrical and mechanical aspects of the design.
- Dr. Russo for providing support and feedback to the group to ensure the design of the project meets the needs of the National Park Service

Abstract

The following report will discuss the summation of Team 18's progress during the fall 2014 semester. The team was given the task to design and prototype a penetrometer for the National Park Services (NPS). The penetrometer will be used to assist archaeologist in identifying different soil types and in locating midden at their dig sites. Midden is soil that contains domestic waste and artefacts of past human occupation. The penetrometer must be easy to use, portable, weigh less than 50 pounds, and be reliable. The penetrometer will also have the ability to wirelessly transmit the data to a handheld Android device. Taking into account the design from last year's team, the requirements and wants from the sponsor, and the research conducted by the team members, the team has come up with a final design for the penetrometer prototype. This prototype will utilize a drop weight similar to last year's design, either two load cells or two strain gauges in the shaft to obtain the friction coefficient, and a personalized app and DAQ system to obtain the experimental data. Further testing will be conducted to determine whether load cells or strain gauges should be used. The EE's have finalized their decisions on the electrical equipment, which includes the wireless DAQ, the laser range finder, the LCD screen, and the voltage regulator. To keep the team on schedule, a Gantt chart was developed, as shown in Appendix A. Constant communication as also been kept between the team and the advisor, instructors, and sponsor, in order to seek guidance and have transparency on the project.

1. Introduction

The objective of this project is to design and build an instrument that can identify midden in remote locations and differentiate soil types at various depths. The prototype must be relatively lightweight, have strength in compression, and be portable. The penetrometer was originally used as an agricultural tool to determine the soil compaction, which helped farmers decide if the soil could be used for crop production. Due to varied results from site to site, a standard design of the penetrometer was developed. Archaeologists use penetrometers to locate soil midden levels as well as determine how deep it runs below the ground. This information can assist archaeologists in verifying if there is organic material present at the test site. Team 18 will develop a prototype of a penetrometer that is portable, wireless, and easy to use in the field. This penetrometer prototype will determine the type of soil by calculating the friction coefficient of the soil. The prototype should produce reliable data that can be transmitted to a handheld device. The team will implement a decision design matrix in order to properly choose the most reliable design for the National Park Services.

In order to stay on task, the team will develop a Gantt chart that will be updated throughout the semester. Certain members in the team will have different areas to focus on in order to successfully manage and complete the team's goals and tasks at hand. Staff and group meetings will be held weekly and biweekly to keep everyone involved.

2. Project Definition

The following project definition will explain the Team's background research of the project, need statement, goal statements, objectives and constraints of the senior design project.

2.1. Background Research

A penetrometer is a basic force instrument in design and simple in use. However, it cannot be effectively used by a novice for precise results. Originally, a penetrometer was used by agricultural personnel for penetration of the ground soil on several acres of land to determine the soil compaction and how viable the soil will be for crop production. Before a standardized penetrometer, results could vary from farm to farm and with different surveying teams. Depending on the varying level of experience by the surveying team, these results can either be interpreted as good or bad soil results. To account for this inexperience during surveying of the ground, calculations will be used to be unbiased in the testing of the soil composition and compaction before any ground comparisons need to be done via a computer.

The standard design of a penetrometer was adopted by the American Society of Agricultural Engineers in 1999 and with this standard design the comparison of data across a wide range of locations could be compared and used for soil compaction. This design calls for a 30 degree cone angle and the use of a 1/2 inch or 3/4 inch base cone as seen in Figure 1. These dimensions more closely resemble a root growing and penetrating the ground as it grows and with certain ground compaction can yield higher or lower crop turn out.¹

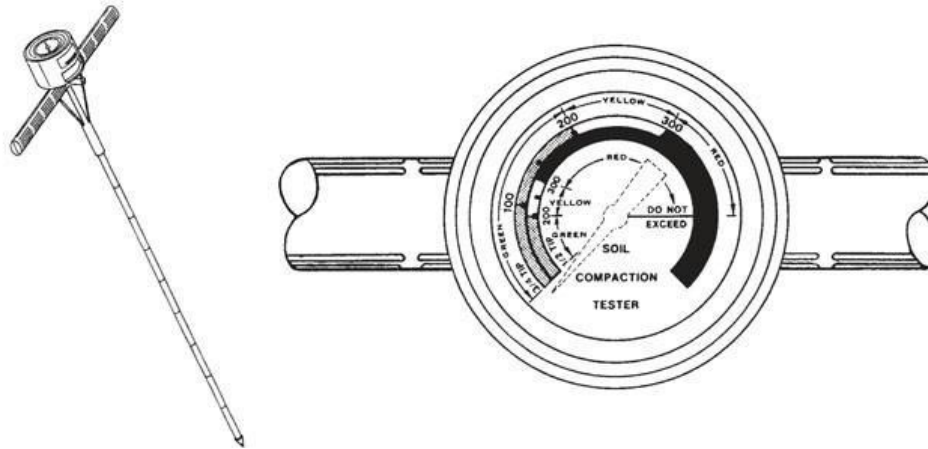

Figure 1. Standardized Penetrometer Design²

In the field of archaeology, soil compaction and composition can save a lot of time and money from large excavation digging to uncover important soil types shallow or deep underneath the top soil. A penetrometer is being used to detect the location of midden, which is archaeological soil type produced from decomposed artefacts that were tossed into the environment during the time of population in that certain location. The used method to determine the midden is a basic T-bar penetrometer that has several extendable rods that can allow for several meters of distance to map the location and depth of midden. When used by an experienced surveying team, the midden can be located based on the "feel" of the midden soil type as the compaction and compression is different than the surrounding soil types. This feel can be misinterpreted by an inexperienced surveyor and the data collected could be wrong. To account for this inexperience, load cells can be used along with a computer program to determine the depth and soil types.

One method closely related to our approach on the penetrometer is the cone penetrometer test (CPT) which incorporates an electronic friction cone and piezocone penetrometer as seen in Figure 2. When used to test the soil composition and compaction, a computer logs the values from the cone and friction sleeve and uses the ratio to determine if the soil is suitable for use. Using this same concept of separating load cells to determine the friction ratio, archaeological dirt can be determined several meters under the topsoil without digging several holes. The surveying team using the device with not need a high level of experience as the data collected will be based on calculated values to determine the actual soil that is being penetrated.³

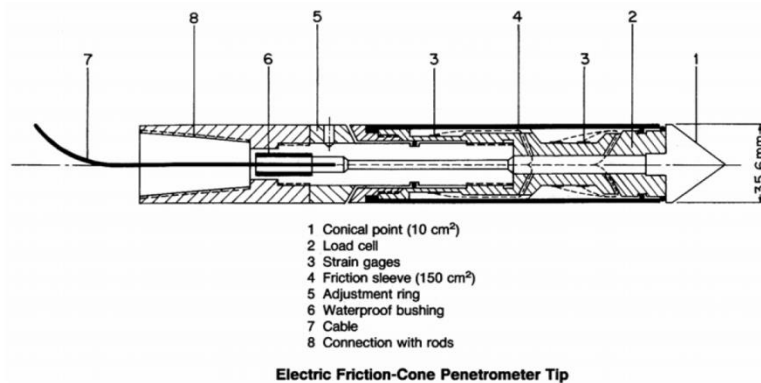

Figure 2. Electric Components of the Penetrometer Tip^[3]

2.2. Need Statement

As an extension of the 2013-2014 senior design project, it is the object of Team 18 to redesign a penetrometer which will detect midden levels in the soil present at the Southeast Archaeological Center & National Park Services' field testing site. This penetrometer will have portable and wireless capabilities in order to properly distinguish the type of soil present below the ground. It has been established that the sponsor is looking for a more reliable and easier-to-use system than the prototype designed by the previous senior design project. Currently, this year's project has been to redesign last year's design project. Team 18 has taken the prototype out into the field at the National Park Services' testing site. However, upon the first day of field testing, the epoxy failed and the tip of the penetrometer no longer took input readings. With the failed prototype as an example, Team 18 has gathered much information as what not to do with this year's design.

“It is difficult to distinguish soil midden levels apart from other organic and mineral soil levels when field testing on site.”

2.3. Goal Statement and Objectives

Goal Statement: “Design an instrument that can identify midden and differentiate soil types at various depths.”

Objectives:

The following objectives were provided to the Team from discussion with the National Park Service and Dr. Russo, the Team's sponsor.

- Must be able to identify midden levels in remote locations.
- Must weigh less than 50 lbs.
- Must be able to reach depths past 20 feet.
- Should wirelessly display results to a handheld device.
- Device should be very portable.
- Weight should be minimized.

2.4. Constraints

Listed below are the constraints placed on the design. If a design does not meet the listed constraints, the design will not be considered.

- The prototype design must be easy to use.
- The prototype must be able to be used by one person in the field, without assistance.
- The diameter of the prototype must be small enough for the device to penetrate the ground easily.
- The material of the prototype must be strong enough for the device to penetrate the ground without fracturing.
- The prototype design must be able to determine the location of midden and how deep the midden runs.
- The prototype design must be wireless, allowing it to be portable.
- The weight of the prototype must not exceed 50 pounds.
- The data from the device must be reliable.
- The prototype design must allow for wireless data transmission to a handheld device.
- The total cost must not initially exceed \$2,000.
 - The sponsor is able to expand the budget if it is deemed necessary by the team and the advisor.

3. Design and Analysis

3.1. Functional Analysis

Penetration Shaft

The penetration shaft is one of the most important components of this device. While the shaft penetrates the ground, it will be exposed to debris, rocks, and shells in the soil. The shaft must be strong enough to withstand the applied load that will force it into the ground, and also must not fracture while breaking through shells or rocks. The load cells or strain gauges will be placed either on the bottom of the penetration shaft or in a housing near the handle. If extensions are added while using the penetrometer, they will be added between to the top of the penetration shaft.

Load Cells

Load cells are measuring devices that create an electrical signal directly proportional to the force being applied to the cell. In this project's application, load cells can potentially be used to measure the load applied to the soil. When measuring the results with two load cells in a friction sleeve, the friction of the soil can hypothetically be found. This will enable the penetrometer to identify what type of soil it is penetrating into. Last year's design group attempted to use load cells but ran into trouble due to the size of the cells. If smaller, more accurate cells can be found, load cells can prove to be very valuable to the success of this project.

Strain Gauges

A strain gauge consists of a backing and metallic foil that is insulated by adhesive material such as cyanoacrylate. The strain gauge is fixed to the surface of the material that is experiencing strain and as the material deforms the strain gauge deforms with the material and this change in resistance is measured using a Wheatstone bridge as seen in Figure 3 and 4. As the strain gauge is deformed in the vertical or horizontal direction, the internal conductance of the foil will stretch or be compressed and this allows for a difference in voltage to be measured in the Wheatstone bridge configuration. In this configuration the four resistors must be matched while at equilibrium and by changing each resistor with the exact same resistive strain gauge the sensitivity and accuracy of the Wheatstone bridge will increase and be able to measure more strain to the specimen.

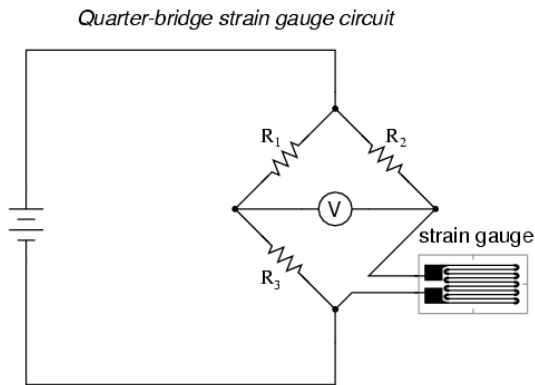

Figure 3. Wheatstone Bridge Configuration

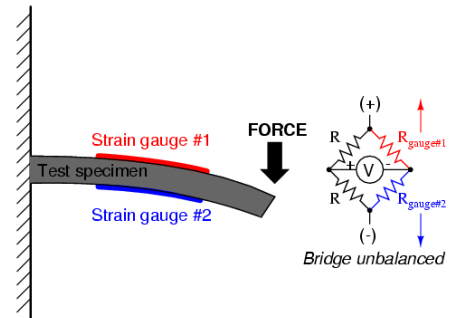

Figure 4. Force Displacement

For the needed friction coefficient being calculated for in field testing, two separate but comparable voltages must be read: one due to the impact force from the load striking the rod and one measurement from the ground reactive force. To be able to accurately measure the strain being produced on the rod, a four strain gauge Wheatstone bridge will be explored, with each strain gauge 90 degrees from each other on the strained rod. As the weight impacts the center rod, the rod will deflect slightly due to the force and material type and this deflection will be measured by the strain gauges attached to the rod. In order for the rod to experience a deflection, a slight clearance will have to be calculated so the rod will deflect due to the force. This voltage will be taken as the control and compared to the later voltage from the secondary Wheatstone bridge. On the other end of the rod, the cone will have a force applied to it that is near identical to the force struck at the top and the cone will penetrate the ground. As the cone penetrates the ground the rod will experience a deflection due to the compaction of the soil. If the soil is softer, dirt or soft sand, the cone will have less resistance, have a lower deflection, and less voltage will be created

from the Wheatstone bridge as seen in Figure 5. If the ground is hard, clay or shells, the cone will experience a high resistance to penetrating the ground. The force being measure will almost be equal to the applied force. This difference in the voltages will be used to determine the separation of soil compaction types and their depths below the top soil.

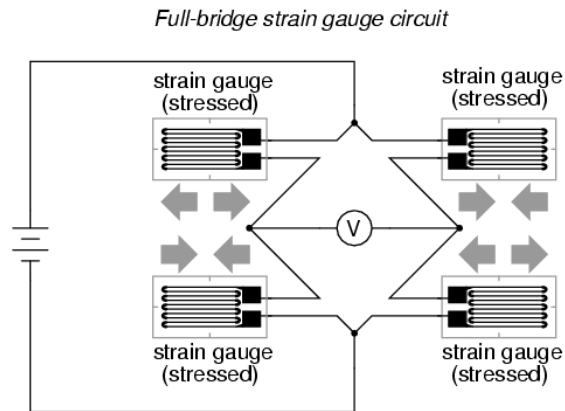

Figure 5. Strain Gauge Circuit

For the strain gauge design, the strain deflection of the material can be in either the horizontal direction or the vertical direction. The bottom strain gauge reads the penetration cone at the bottom of the rod. The two diagrams below in Figure 6 and 7, show that the top force applied will be from the drop weight will be a constant force and the applied force for the bottom elastic material will be from the penetration cone and given the compaction of the soil this will yield a different force to the strain gauges.

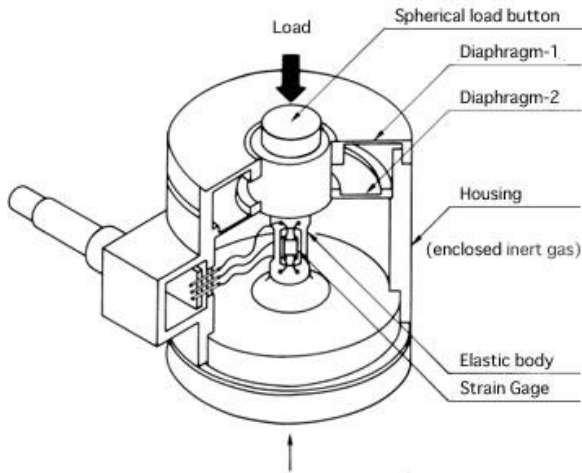

Figure 6. Load Cell Configuration

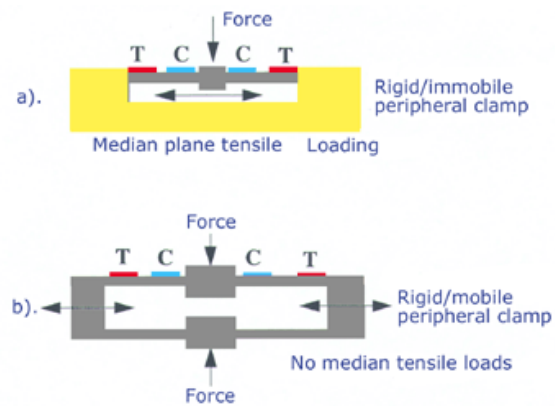

Figure 7. Strain Gauge Loading Displacement

Penetration Method

Two methods of penetration are currently being considered. The first method is manual penetration using a T-bar handle. This is the type of penetrometer the sponsor currently uses. The user would repetitively force the device into the ground using his or her own body weight. The current use of this method is not an exact science; the user will “feel” for changes in the soil when using a T-bar penetrometer. The addition of the data acquisition unit will allow for non-bias collection of data. This method is easy to transport and use, due to its lightweight and simple design, but the large applied load may be harsh on the electrical components.

The second method of penetration is using the drop weight method. This was the method implemented in last year’s design. In this method, a user would repetitively drop a weight of known mass from the top of the

penetrometer to a second marked height, forcing the penetration shaft into the ground. With this design, the load cells or strain gauges would be placed at the bottom of the penetration shaft, just above the friction cone. Although this method provides a more consistent applied force, the drop weight would increase the overall weight of the device.

BTH-1208LS Wireless Multifunctional Data Acquisition (DAQ)

The DAQ shown in Figure 9 acquires data over Bluetooth or USB connection. The device will record the output voltage from the load cells/strain gauges and relay the data to an Android device running an application that will be developed by the team through Bluetooth. The specifications can be seen in Figure 8.

Analog Input	
Sample Rate:	47 kS/s
Number of Channels:	8 SE/ 4 DI
Range, Bipolar:	-20 to 20V, -10 to 10, -5 to 5, -4 to 4V, -2.5 to 2.5, -2 to 2, -1.25 to 1.25, -1 to 1
Resolution:	12 bit
Analog Output	
Resolution:	12 bit
Number of Channels:	2
Range, Unipolar:	0 to 2.5V
Digital I/O	
Number of Channels:	8
Counter Timer	
Counter Inputs:	1
Counter Resolution:	32 bit
Measurement Type	
Measurement Type:	Voltage Output , Counter , Digital I/O , Multifunction
Interface List	
Interface:	Wireless



Figure 8. Wireless DAQ specifications

Figure 9. Wireless DAQ

Laser Range Finder

The laser range finder shown in Figure 10 is a device from last year’s design. This device uses a laser and a reference point on the penetrometer. As the penetrometer travels into the soil, the reference point will move closer to the laser and measure the displacement. This displacement is the distance the tip of the penetrometer has travelled. This device measures and records the depth and sends the information to an Android device running an application developed by the company, Vertek.



Figure 10. Laser Range Finder

Texas Instruments UA7810 10V Voltage Regulator

A Texas Instruments 10V voltage regulator shown in Figure 11 will be used to ensure that a fixed 10V will be provided to the load cells or strain gauges. The voltage regulator has a maximum input voltage of 28V and a minimum input voltage of 12.5V. A 14V rechargeable battery will supply the input voltage for this project.



Figure 11. Texas Instruments Voltage Regulator

3.2. Design Concepts

Mechanical Design A

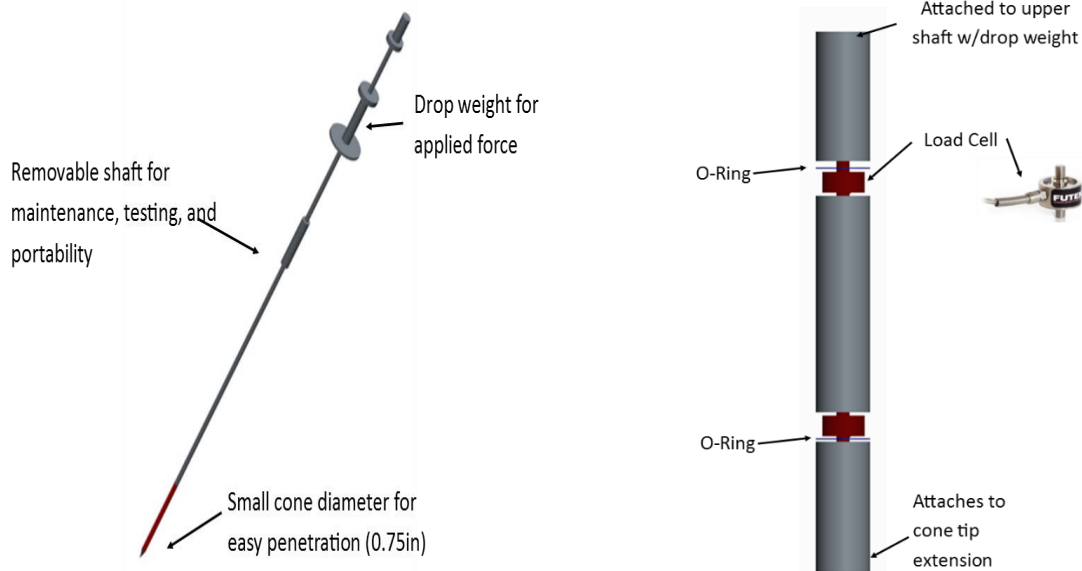

Figure 12. Mechanical Design A

Last year's prototype was not as successful as hoped. But revisiting last year's design and making a few alterations may produce a successful prototype. The design as seen in Figure 12, is based on the current drop weight penetrometers used by archaeologists in the field. A weight of a known mass is placed on the top half of the shaft. The weight is repeatedly raised to the top of the shaft and then dropped in order to force the penetrometer into the ground. There are two stoppers on the shaft, one at the top to mark the height to which the weight will be raised, and one in the middle of the shaft to stop the weight from falling to the bottom. These two stoppers create a consistent distance for the weight to fall every time. Two load cells are placed at the bottom of the penetrometer just above the friction cone tip to obtain the voltage readings. The load cells are placed inside of a friction sleeve; this allows a fictional force to be read, which is used to calculate the friction coefficient of the soil.

To improve last year's design, changes need to be made mainly to the shaft, the load cell design, and the portability. The shaft of the penetrometer needs to be strong under repetitive compressive forces, but last year's design fractured multiple times in the field while in use. The compressive strength of the shaft needs to be increased,

which can be done by choosing a stronger material, such as titanium, or by adding ceramic fibers. Ceramics are stronger under compressive loads than most metals, therefore in ceramic fibers were added into the metal shaft, the overall yield strength would increase. The load cells used for the prototype last year were large in size, forcing the shaft diameter to increase. Using smaller load cells would allow for a thinner penetrometer, which would permit easier entry into the ground. The wiring of the load cells was not housed, exposing it to any surrounding elements. The wires should be housed inside the penetrometer shaft or in a secure box at the top of the penetrometer. The prototype from last year was heavy and had to be carried in multiple parts, not making it portable. It also required a generator in the field for the multimeters to function. The weight of the penetrometer would need to be reduced significantly, and a different source of power, such as an internal battery, would need to be implemented.

Mechanical Design B

Mechanical design B looks exactly like design A in Figure 12. The main and very important difference between these two models is the actual location of the load cells. In design A, the cells are at the bottom of the shaft and have a direct impact with the soil. In design B, the load cells are at the top of the shaft. This makes it much easier to keep the load cells weather resistant and it enables a larger sized load cell without having a large shaft diameter. Testing will have to be done with material choices to ensure the load from the bottom of the shaft can accurately be transferred to the load cells at the top of the shaft. Another modification to this design is the housing. Since the model is to be wireless and battery operated, it would make sense to have a separate housing from the actual shaft itself. This will make for a lighter moving T-bar and easier use in the field. It will also keep the electrical equipment from getting damaged from repetitive compressive loads.

Mechanical Design C & D

Mechanical design C and D, as seen in Figure 13 below, utilize the drop weight as its main form of applied load just as in Figure 12, this applied standard load allows for consistent data applied to the top strain gauge. For both designs the strain gauge method will be explored, the top compartment will receive the load applied from the drop weight and as the force is transferred through the rod the secondary load cell will be placed directly above the penetration cone allowing for less forces to be lost from the transfer of the force from the ground. The difference between both designs lies in the actual placement of the strain gauges and the housing of the strain gauges that will be receiving the impact force. For design C, the strain gauges will be set up in a vertical orientation along a material specimen that will experience a deformation in the horizontal direction much like the diagram shows above in section 3.1 and for design D, the strain gauges will be set up in a horizontal orientation and the load applied will create a deflection of the material specimen in the vertical direction. Both of these concepts will be explored more deeply for sensitivity levels and accurate transfer of the applied load.

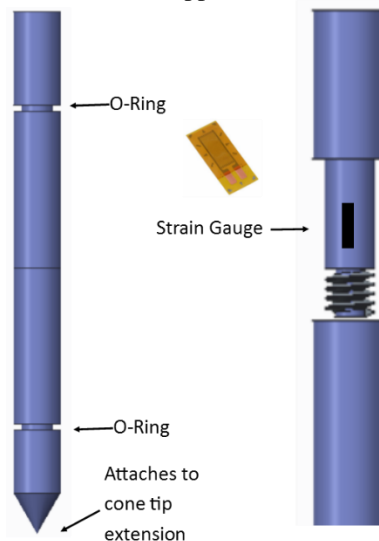

Figure 13. Mechanical Design C & D

The block diagram in Figure 14 is the electrical design. The load cells or strain gauges will be powered by a 14 V rechargeable battery that can be replaced in the field if the battery dies. A 10 V voltage regulator is connected

to the battery to ensure that the specified 10 V is supplied to the load cells or strain gauges. The wireless DAQ is powered by two rechargeable AA batteries and will directly record the output voltage of the load cells or strain gauges. The battery and wireless DAQ will be placed in an electrical housing to protect from the elements of nature such as water, dirt, etc. The wireless DAQ will then send the data via Bluetooth to an Android tablet running an application (app) to be developed by the team. The app will display real time results and store the data for further analysis. The laser range finder also runs on two AA batteries, and will record the depth that the penetrometer travels into the soil. This data is sent through Bluetooth to an Android cell phone running an app created by Vertek. Once the phone is paired with the laser range finder, it will notify the user that a measurement is recorded, and when it is ready for the next measurement to be taken with a “beep” sound. The data is displayed on the app and generates a soil profile to be saved for further analysis.

The electrical design can be tested independently without the mechanical aspect of the design. The wireless DAQ can be used to simulate the load cells or strain gauges by recording output voltages from the penetrometer design from last year, or by simply connecting it to a waveform generator. The laser range finder has been tested in the field previously and functions properly. The team will further test the laser range finder to validate how accurately the laser range finder measures the distance that the penetrometer travels through the soil. The data range finder simply measures the distance that the penetrometer travels into the soil, so this can also be tested using the penetrometer design from last year. The app that will be developed is expected to undergo constant improvements and changes as the design progresses. This part of the electrical design will require the most amount of time to complete due to the level of programming and team inexperience of developing an Android app.

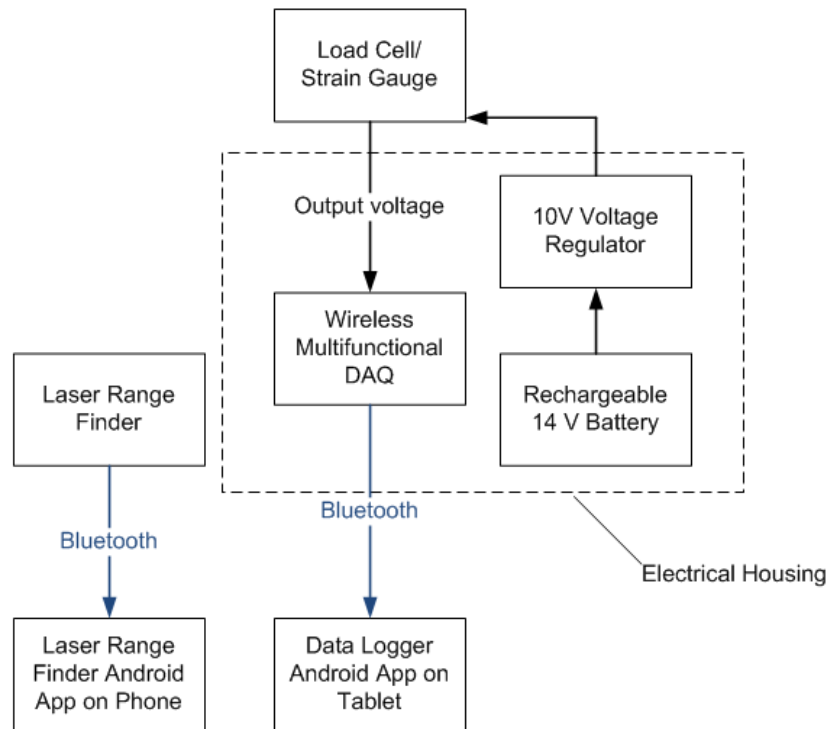

Figure 14. Electrical Block Diagram

3.3 Design Matrix Criteria

Below, in Table 1, is the design matrix for the four mechanical designs. From this Figure, it can be seen that design D is the most likely candidate for the final design choice. The importance of each section of criteria will be discussed in the following section.

		Portability		Ease of Use		Weight		Measurability		Durability		Cost		Total
Weight (%)		0.30		0.25		0.15		0.15		0.10		0.05		1.00
Designs	A	Score	Total	Score	Total	Score	Total	Score	Total	Score	Total	Score	Total	4.95
		4	1.2	6	1.5	2	0.3	8	1.2	5	0.5	5	0.25	
	B	Score	Total	Score	Total	Score	Total	Score	Total	Score	Total	Score	Total	5.7
		5	1.5	6	1.5	7	1.05	5	0.75	6	0.6	6	0.3	
	C	Score	Total	Score	Total	Score	Total	Score	Total	Score	Total	Score	Total	6.25
		5	1.5	8	2	8	1.2	6	0.9	3	0.3	7	0.35	
	D	Score	Total	Score	Total	Score	Total	Score	Total	Score	Total	Score	Total	6.65
		5	1.5	8	2	8	1.2	6	0.9	7	0.7	7	0.35	

Table 1. Design Decision Matrix

3.3.1. Evaluation of Designs

The Mechanical design criteria for the selection of a final design consists of six main categories based on the project objectives and goals developed earlier. The six categories, in order of descending weight, are: portability, ease of use, weight, measurability, durability, and cost.

- **Portability:** Portability is the top priority when designing the penetrometer. The device will be used continuously for 8-9 hours, and the user will be moving across the work site to test multiple areas. If the device cannot be transported easily, it is of no use. It should not take more than two people to transport the device, and the device should not have to be transported as many separate parts.
- **Ease of Use:** The device must be able to be operated by 1-2 people while in the field. The setup, use, and breakdown of the penetrometer must be simple and quick to allow for more time to test holes at the work site with little to no complications.
- **Weight:** The weight of the mechanism must be light enough to be carried to and from the work site, and transported across the work site continuously. The goal is to construct a device that weighs no more than 50 pounds.
- **Measurability:** The purpose of using this device over the current method is to remove any bias that may come from the user of the penetrometer. Therefore, the device must deliver reliable data and results.
- **Durability:** The mechanism must be extremely durable because the user will not be able to make any major repairs in the field. The shaft, friction cone tip, and handle should not crack or fracture at any time during use.
- **Cost:** The cost is of the lowest weight because our sponsor has made clear that the top priority is to construct a feasible prototype. While we are taken our given budget into heavy consideration, our sponsor has informed us that if we do need more funding to purchase materials of a higher quality, he will be willing to consider increasing the budget.

The Electrical design criteria for the selection of a final design consists of five main categories based on the project objectives and goals developed earlier. The five categories, in order of descending weight, are: ease of use, portability/wireless, durability, and cost.

- **Ease of Use:** The application developed to display real-time results on an android device must be able to display results without any configuration by the user.
- **Portability/Wireless:** The connection between the android device and the data acquisition must not impede efficient work in the field because the users need to be able to move from hole to hole with ease during an 8 hour period. It is imperative that the user can carry all of the equipment with very few wires so that the user does not have to spend time or energy untangling wires.
- **Durability:** The android device and the data acquisition must be able to withstand typical weather conditions and possible contact to dirt. The user should not have to worry about the data acquisition or android device failing because of typical weather conditions in Florida.
- **Cost:** The price of the data acquisition system and the android device should not exceed the amount of money that the sponsor is willing to spend.

3.3.2. Selection of Optimum Designs

Using the design matrix with the chosen criteria, the best design concept is design D, which utilizes strain gauges mounted vertically on the penetration shaft. This design had the highest score, or tied for the highest score, in five out of the six categories. It scored low in the measurability section, but we will look into ways to improve the reliability of the data gathered when using this design. Design D tied with design C, which is the alternative strain gauge design, on five out of the six categories because there were only a few minor differences between the two designs. The major difference was the alignment of the strain gauges within the penetration shaft; the alignment is the cause of the drastic difference between the scores of the two designs in the durability section. When the strain gauges are loaded vertically on the shaft, they are able to withstand a greater load. When all the criteria are combined, design D had the highest score, making it the best choice to consider for our final mechanical design concept.

4. Risk and Reliability

Penetrometers are very safe instruments to use. However, there are a few safety features to pay attention to. Since we have decided to go with a drop weight as our load source, there is danger in dropping the weight on the lower hand. It is necessary to be careful in the users hand placement. There will be an obviously place to hold the penetrometer before dropping the weight as part of the design. Also, the weight of the penetrometer is limited to 50lbs. This is still a significant amount of weight to be carrying around the field all day. The case for the penetrometer will be constructed as a supportive backpack or rolling case to ensure the least amount of hassle to the user. Other than the weight there are no safety risks associated with the user although there are risks with how we design the penetrometer. Moisture, dirt, and other environmental residue will be in abundance where this device is used. It is imperative that the seals being used on the design are tight enough to defer all of these materials. If not, the strain gauge, or load cell can be destroyed or off in calibration.

When it comes to load cells, the readings received are a lot more reliable. A load cell contains a strain gauge the only difference being that it is housed and previously calibrated for the user. The problem with load cells is the size of the cells themselves. With strain gauges there is quite a bit more risk. It is very hard to install the strain gauges onto the interior shaft as they have to be aligned perfectly and connected to a Wheatstone bridge. If any water or dirt gets into the interior of the shaft where the strain gauges are housed they are sure to be ruined.

To ensure a reliable design, the housing for either the load cells or strain gauges will be tested prior to manufacturing the final design. A carrying case for the penetrometer will ensure the least amount of weight is pulled by the user and will ensure it is not too heavy to carry around the field. The data received from the final design will be tested several times to document error in readings and ensure it is reliable.

5. Detailed Design and Design for Manufacturing

Team 18 is currently finalizing the shaft design for the penetrometer and planning on ordering the parts from the machine shop immediately upon return from winter break. The electrical components for the final design are already finalized and orders have been placed for procurement before winter break in hopes to have everything in stock the day spring semester starts up. Testing of the electrical equipment will start immediately whether the mechanical shaft is finalized or not. The electrical engineers are programming a simulation so all of the equipment can be calibrated and tested before the final installation.

With the finalized shaft design approved by Dr. Shih, Team 18 plans on double checking the ProE drawings and then ordering the material to be machined. The College of Engineering's machine shop does not machine Titanium so the team is considering outsourcing our machining work. Otherwise the material may be changed to something more easily machined.

After the parts come back from the shop, the shaft will be connected and the overall penetrometer will be built. From here the testing will begin. The seals will be tested for leaks and how well they fair in the soil before the equipment is installed inside the shaft. After the seals pass the tests, the electrical equipment and load cells will be added to the shaft for a fully constructed penetrometer.

With the entire penetrometer intact, bucket tests will be done to get readings on various soil types. These readings will be compared to see if the data the penetrometer is taking in is different and accurate enough to read soil types. Further changes will be made on a need basis to make sure the design is a working model. The model will be tested for accuracy, reliability, and feasibility. The end goal of this project has never been done before so sufficient testing is needed to ensure a potentially working device. After the penetrometer is confirmed to work, the housing for the electronics and the portability of the model will be worked on before finalizing the design for the sponsor.

6. Future Plans for Prototyping and Others

Due to concerns from faculty and our advisor, Dr. Shih, the double load cell design and double strain gauge design will be looked at more carefully in the upcoming week. This comes from the coupling of the two loads that are aligned linearly on the shaft and before accurate data can be acquired from our design we must consult with other faculty members on methods of de-coupling the two loads associated with the friction coefficient. We will be talking with Dr. Shih about other methods of do this but due to this concern a final design will not be tested until further analysis is complete.

This concern of the two read forces will not slow the process of ordering and testing components associated with the electrical side of the penetrometer. This will include the data acquisition module component, voltage regulator, op amp, and battery components. Alongside these components, a few mechanical components will also be ordered, such as the load cells that will be used in the final penetrometer, strain gauges, and steel rods. These components will be used to test and calibrate the electrical components that will be used on the final penetrometer design.

One component that will be reused from last year's design is a drop weight component of the penetrometer. The drop weight is two pieces: the weighted steel, either 10 lbs or 25 lbs, and the rod that the weight slides on. These two components screw into the load cell compartment located in the top of the penetration rod or the penetration rod itself in the case of the strain gauges. These weights will be measured on how much force can be produced on the ground and what kind of voltage will be produced from the load cells and strain gauges and this will be helpful in the calibration and testing of the electrical components.

After analysis of the load cell and strain gauge designs, and an alternative method of measuring two separate forces is found, final models will be created for the housing of the load cells and strain gauges along with modelling of the housing of the electrical components and tri-pod system used for balancing the penetrometer. Once all models and analyses are complete the materials ordered will be sent to be machined by the College of Engineering machine shop or being outsourced to a private company if titanium is to be used as an alternative material.

7. Procurement

7.1. Procurement & Budget Analysis

The budget allotted to the friction cone penetrometer team is in the amount of \$2,000.00. Based on our sponsor’s criteria and constraints, this penetrometer will be made of high class materials and able to withstand the environment and repeatability and to accomplish this goal the sponsor has stated that a larger budget can be used for our project to complete the product required for the sponsor. Due to requirements from the university, we will be aiming to stay below the budget first given to our team for the project until otherwise stated. The two Figures below show the procurement break down of the electrical and mechanical components to be purchased for our project.

The total amount of the electrical components and mechanical components are highlighted at the bottom of each table respectively as seen in table 2 and 3. The electrical components came to a total of \$488.61 which does not include shipping, taxes or other associated fees from the seller and represents 24.4% of our total allotted budget. The mechanical components’ total also does not represent and fees associated with manufacturing and shipping the materials and the total is \$1,386.46 which is 69.3% of our total allotted budget. The combined total cost of this purchase will be \$1,875.07 and represents 93.7% of our total budget.

Description	Company	Model	Price	Quantity	Total Price
Wireless DAQ	MCC DAQ	BTH-1208LS	\$199.00	1	\$199.00
Voltage Regulator	Texas Instruments	UA7819	\$0.84	1	\$0.84
Battery	AA Portable Power Corp	HLP-6745135K-PCM	\$124.95	2	\$249.90
Battery Charger	AA Portable Power Corp	CH-L1483	\$36.95	1	\$36.95
Op Amp	Texas Instruments	TLV2781	\$1.92	1	\$1.92
Total					\$488.61

Table 2. Electrical Components Procurement

Description	Company	Model	Price	Quantity	Total Price
Strain Gauge	DIGI-KEY	1033-1016-ND	\$44.67	10	\$446.70
Load Cell	Futek	FSH02631	\$450.00	2	\$900.00
Steel Rod (3/4")	MSC	52418340	\$26.56	1	\$26.56
Steel Rod (1/2")	MSC	52418324	\$13.20	1	\$13.20
Total					\$1,386.46

Table 3. Mechanical Components Procurement

8. Communication

Throughout this semester, Team 18 has communicated efficiently and effectively between one another, their sponsors, and their mentors/instructors. The most important form of communication has been through the team's email: nps18@gmail.com. Team 18 set this email up so that there would be one email to communicate between the team members. Both the team's sponsor, Mike Russo, and the team's advisor, Dr. Shih, have sent emails to this email address. The team has even set up a Google Drive to upload deliverables, ProE drawings, and other important documentations imperative for this project. Carren Brown has served as the Team Ambassador throughout the fall semester and has helped the team's communication between the Mechanical and Electrical departments.

In addition to the email correspondence, the team meets once to twice a week to update on another on their progress throughout the semester. Bi-weekly reports are conducted between the team and their instructors and mentors. These reports help update the instructors on the student's progress as well as open the floor to ask any questions the students may need help or advice on how to overcome obstacles with their design. After each presentation, the team meets with their sponsor, Mike Russo, to keep him up to date as well as provide him an opportunity to raise any questions or concerns he may have with the team's progress. Dr. Shih is frequently involved with this project, and he is update about every two weeks.

9. Methodology

To begin the project, the team will research existing penetrometer designs that are relevant to the project. The team shall also review the progress made on the project by last year's team; this includes reviewing their reports and testing their prototype. The team will then determine the range of values that need to be read by the device, based upon the wants of the sponsor. The team shall also discuss with the sponsor what he would prefer in the design for performance, reliability, and portability. Simultaneously, the team will explore various wireless data acquisition components and charging methods that could possibly be used in the design. After extensive research has been done, the team will develop and evaluate multiple ideas. The cost of materials shall be estimated for each design. Then, the team will create a decision matrix in order to compare all designs without bias. A final design shall be chosen from this matrix.

After the design has been validated, the team will simulate the design using a computer program. Final decisions on the type and cost of materials will be made. This will all be discussed with the sponsor in order to obtain his approval. After obtaining approval, materials and equipment will be purchased and the prototype will be constructed. After the construction is complete, the prototype will be tested in the field, and the test data will be analysed, with the assistance of the sponsor. After the test performance and results have been analysed, the team will re-evaluate the design and decide upon any necessary or desired changes to the prototype. This may include, but is not limited to, multiple improvements and partial redesign. After these changes have been decided upon, the final prototype shall then be built and test in the field, in the same manner as the previous prototype. Again, the team will discuss the performance and results with the sponsor. If the sponsor approves the prototype, the team will compose the final report of the project and present the final model to the sponsor and advisor, and at the open house event in April 2015.

10. Schedule

After much discussion and planning, a detailed schedule was created to ensure that Group 18 stays on task and up to date on the project's needs; included in the Gantt chart, which can be found in the Appendix on page 23, are three different categories of tasks. They include class deliverables which is what the team actually has to submit for grading and evaluation, team deliverables which are tasks that the team has discussed would help us reach our goals and milestones, and there is also a category for our staff and sponsor meetings. Each task has been assigned specific team members that will help to complete the tasks goals. Some tasks such as the Needs Assessment included everyone in the team, but others are more specific to team member's roles in the group. As a deliverable comes closer, more detail will be added in subcategories as to who is doing which part of the task at hand. Having this detailed schedule will ensure we have a clear path on what is to be done at all times. Changes will be made throughout the semester as new tasks arise and members shift into the roles they feel comfortable in.

10.1 Resource Allocation

Throughout this project, allocated roles will be given to each team member. It can be seen in the table above which specific team member will be assigned to each task throughout the semester. As a whole, it has been decided by the team to work on each deliverable in equal amounts. However, both Sean and Mitchell have the specific tasks of completing any electrical aspect of the project while it is Carren, Peter, Natalie and Maritza's role to complete the mechanical aspects of this project.

As mentioned in the code of conduct, Natalie Marini was allotted the role of Team Leader. This means that she is responsible for enforcing deadlines, keeping team members on task, and developing a plan for optimal project completion. All documents will be finalized and approved by the team leader. She is responsible for communicating effectively between the team members, faculty advisor, and team sponsor. Therefore, she will have the majority of the responsibility of each task that is presented in the Gantt chart. (See appendix)

Peter Hettmann was chosen as Team Treasurer, meaning that he must maintain all records of purchases from the project account and a copy of all receipts. Purchasing information and analysis of the budget before purchasing is the treasurer's appointed job. He will be presented with the majority of the responsibility of any and all money-related issues.

Carren Brown is the team's Ambassador. This includes the responsibility of maintaining correspondence between the ME team members and the ECE team members. She will also coordinate all meetings with team members and keep the group calendar updated with meeting times, due dates, and presentations.

Maritza Whittaker is the team's Secretary and Webmaster. It is her responsibility to serve as the main record keeper and email correspondent. She is to correspond emails between the team and sponsors/advisors/professors throughout the design project. The secretary is also responsible for keeping a record of all meeting minutes and noting what was accomplished during the meeting. As the Webmaster, she is to maintain and run the team's website throughout the design project. She will be responsible for any and all allocated tasks pertaining to the website.

Sean Kane and Mitchell Robinson are the ECE liaisons. They must ensure that ECE tasks are completed on time, responsible for keeping all documentation that pertains to the electrical aspect of the project, and maintains communication with the ME team leader, ECE Coordinator, and ECE Advisor of the project.

Each team member must effectively communicate the thoughts and ideas beneficial to the project as well as stay up-to-date on material and goals of the project. It was the consensus of the entire group to consistently help one another whenever another may deem fit.

Assigned Tasks for Team 18					
Category	Task Name	Duration	Start	Finish	Resource Names
Team Meeting	Design Discussion with Sponsor	1 day	Tue 10/14/14	Tue 10/14/14	Natalie Marini
Team Deliverable	ProE Designs	11 days	Mon 10/6/14	Mon 10/20/14	Natalie Marini, Peter Hettmann
Team Deliverable	EE Design Drawings	11 days	Mon 10/6/14	Mon 10/20/14	Mitchell Robinson, Sean Kane
Team Deliverable	Material Selection	14 days	Tue 10/28/14	Fri 11/14/14	Carren Brown, Maritza Whittaker, Natalie Marini, Peter Hettmann
Team Deliverable	Budget Summary	14 days	Tue 10/28/14	Fri 11/14/14	Peter Hettmann
Team Deliverable	Purchasing of Electrical Materials	17 days	Fri 11/14/14	Mon 12/8/14	Sean Kane, Mitchell Robinson, Peter Hettmann
Team Deliverable	Purchasing of Mechanical Shaft and Components	5 days	Mon 1/12/15	Fri 1/16/15	Carren Brown, Maritza Whittaker, Natalie Marini, Peter Hettmann
Team Deliverable	Machining of Parts	14 days	Fri 1/16/15	Fri 1/30/15	Carren Brown, Maritza Whittaker, Natalie Marini, Peter Hettmann
Team Deliverable	Construction of Design	7 days	Fri 1/30/15	Fri 2/6/15	Carren Brown, Maritza Whittaker, Natalie Marini, Peter Hettmann
Team Deliverable	Testing and Evaluation	5 days	Mon 2/9/15	Fri 2/13/15	Team 18
Team Deliverable	Analysis on Tested Results	7 days	Fri 2/13/15	Fri 2/20/15	Team 18
Team Deliverable	Redesign (if necessary)	11 days	Mon 2/23/15	Fri 2/27/15	Team 18
Team Meeting	Testing at site with Sponsor	1 day	Fri 3/13/15	Fri 3/13/15	Team 18
ME Deliverable	Reporting Final Results	11 days	Thu 3/13/15	Tue 3/24/15	Team 18

Table 4. Assigned Task List

11. Conclusion

The objective for Team 18 is to construct a functioning penetrometer that is able to detect when midden (archaeological remains) is present and identify different types of soil. The penetrometer will adhere to the formulated constraints based upon the requirements and desires of the sponsor, Dr. Russo with the National Park Services. The design specifications include weighing no more than 50 lbs, being portable, being usable by 1-2 people, and having low power consumption. The mechanical aspect includes using the drop weight method for a consistent applied force and implementing strain gauges or load cells to obtain the friction coefficient of the soil. The electrical aspect includes using a replaceable battery and a Bluetooth-enabled data acquisition device to allow data to be wirelessly transmitted to a handheld Android device. After extensive research and discussion with advisors and the sponsor, Team 18 has chosen to construct the penetrometer out of titanium so the shaft will not fracture when in use. Because the machine shop at the College of Engineering cannot machine titanium, steel rods will be used for the prototype. Once the prototype is built, tested, and validated, the team will reconstruct the device out of titanium. The shaft will include a detachable portion that will house the strain gauges or load cells with seals to keep out foreign particles and dirt. The penetrometer will also include an attached housing for the electrical equipment. The materials that have already been finalized will be ordered within the week so that the equipment will be here before the spring semester starts. Further testing will be conducted to determine if load cells or strain gauges should be used; the testing of the electrical equipment will be executed separately from the mechanical portion. The team will keep in constant contact with the advisor, Dr. Shih, and the sponsor, Dr. Russo, to seek advice and to be sure that the design satisfies the requirements. In order to complete the project in a timely manner, the team will follow the schedule laid out in the Gantt chart. Each team member will be utilized in a way that highlights their best qualities and will be held accountable for all assigned tasks.

12. References

- 1 Fee, Rich. "Soil Penetrometers." Probing for Compaction (2005). Successful Farming. Web. 25 Sept. 2014. <http://www.specmeters.com/assets/1/7/soil_penetrometers.pdf>.
- 2 McCauley, Amy, and Clain Jones. "Water and Solute Transport in Soils." Soil and Water Management. Montana State University, 1 Jan. 2005. Web. 26 Sept. 2014. <http://landresources.montana.edu/SWM/PDF/final_SW4_proof_11_18_05.pdf>.
- 3 "NOTES on the CONE PENETROMETER TEST." Web.mst.edu. Advanced Engineering Geology & Geotechnics, 1 Jan. 2004. Web. 25 Sept. 2014. <[http://web.mst.edu/~rogersda/umrcourses/ge441/Cone Penetrometer Test.pdf](http://web.mst.edu/~rogersda/umrcourses/ge441/Cone%20Penetrometer%20Test.pdf)>.

13. Appendix

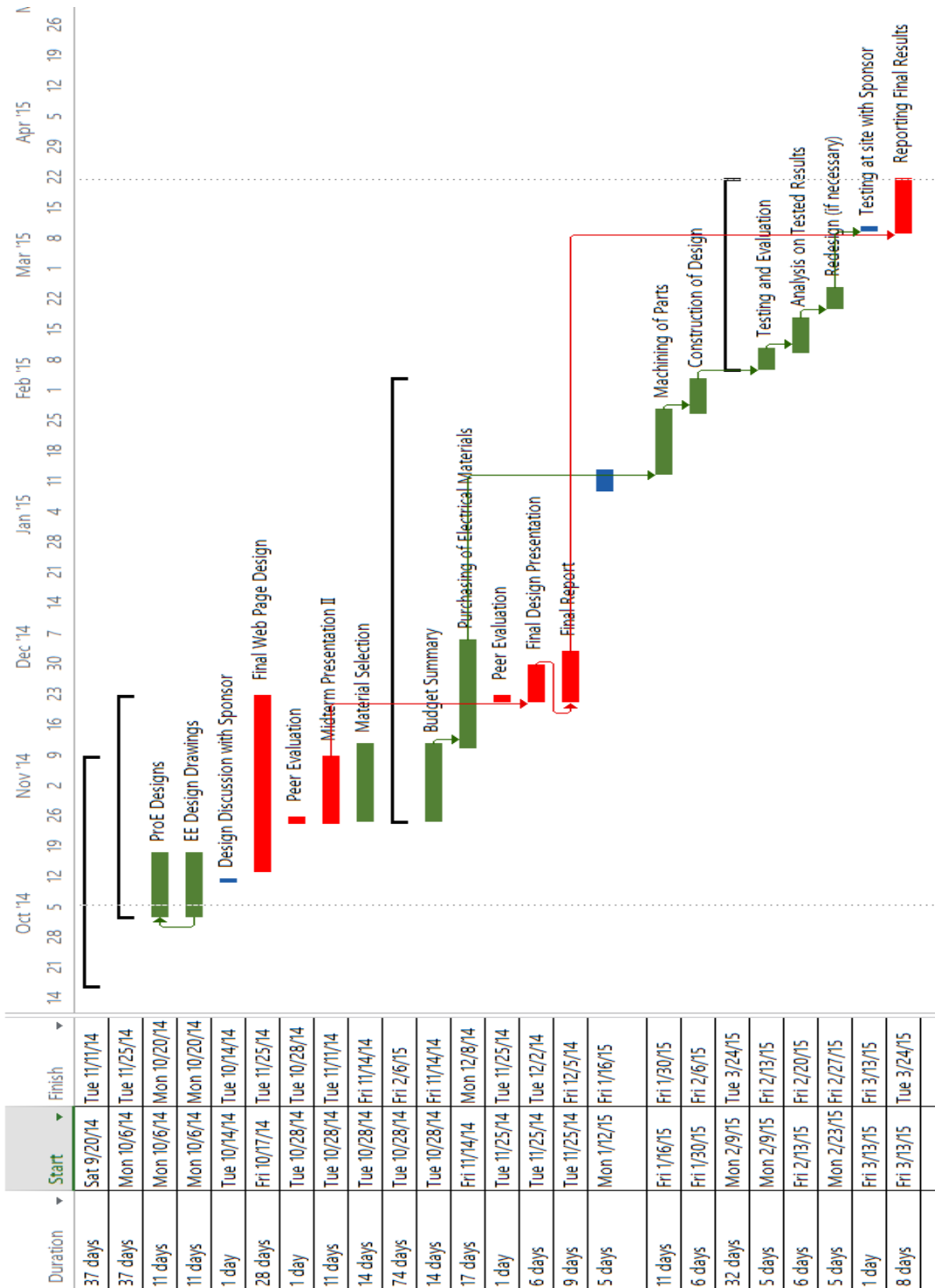

Figure 15. Gantt Chart