

TEAM 18: PENETROMETER

Sponsor: National Park Service - Dr. Russo

Advisor: Dr. Shih

Instructors: Dr. Gupta, Dr. Helzer, Dr. Frank

CARREN BROWN - ME

PETER HETTMANN - ME

SEAN KANE - EE

NATALIE MARINI - ME

MITCHELL ROBINSON - EE

MARITZA WHITTAKER - ME



SCOPE OF PROJECT – PENETROMETER

- National Park Service
- Penetrometer's Current Use
- Design Use
 - Load Cell & Strain Gauge
- Mechanical and Electrical Aspect

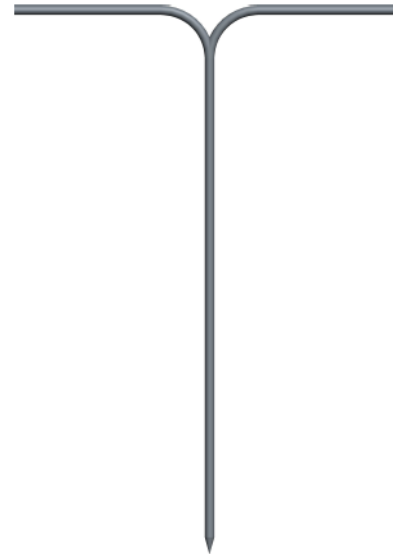

SCOPE OF PROJECT – PENETROMETER

Objectives

- Identify midden levels
- Weigh no more than 50 lbs.
- Should be portable
- Reach at least 20 feet into the ground
- Display results on handheld device

Constraints

- Must be easy to use
- No bending or fracturing
- Locate the midden
- Data should be reliable

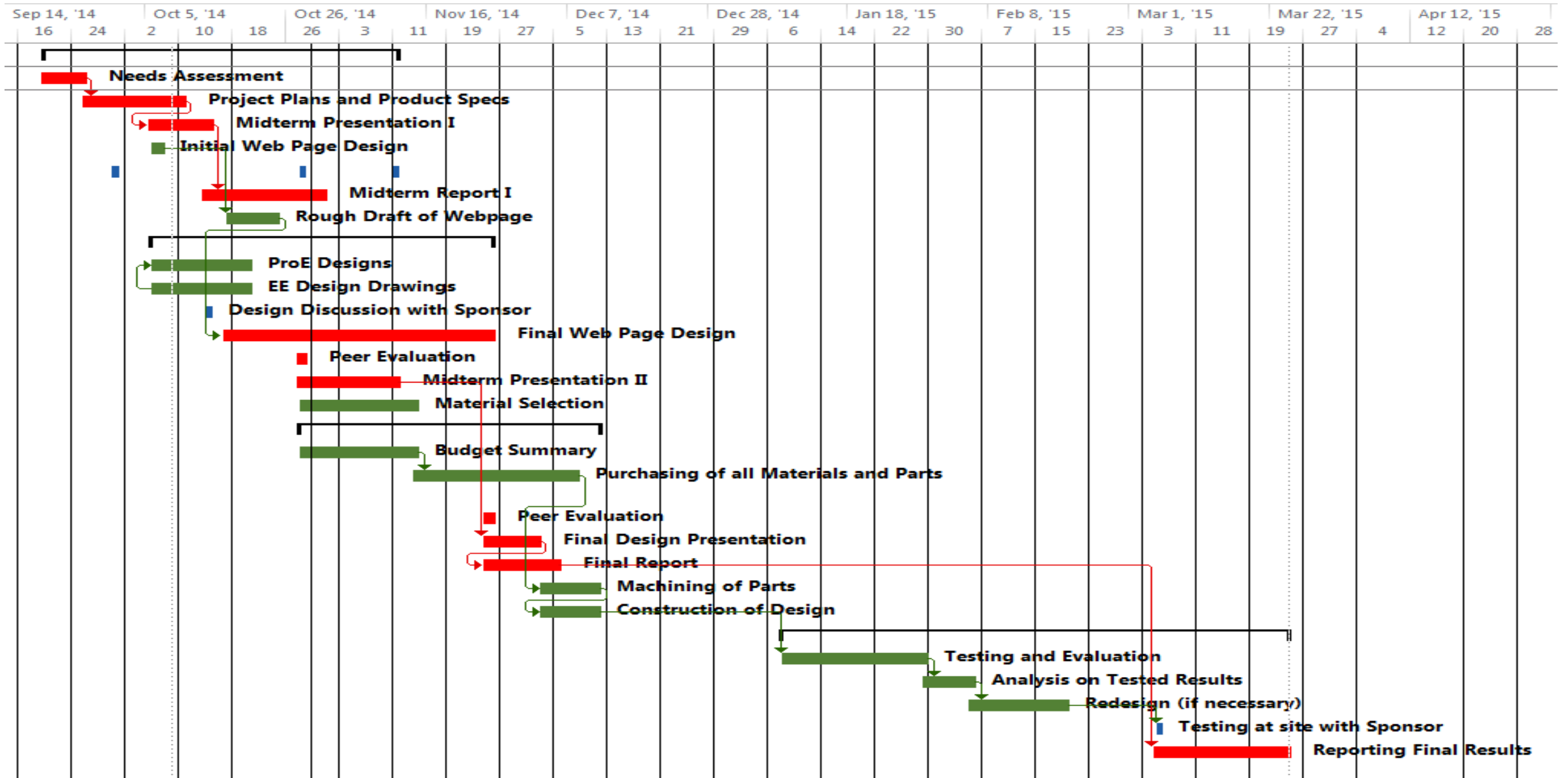

CURRENT DESIGN CONCEPTS

Load Cells

- Protective housing for strain gauges
- Higher load capacities and more readily available
- Larger housing needed for accurate measurement of load



Strain Gauge

- Flexible foil material pasted between two protective materials
- Induced stress changes resistive properties of the foil
- Smaller in size and applied directly to shaft

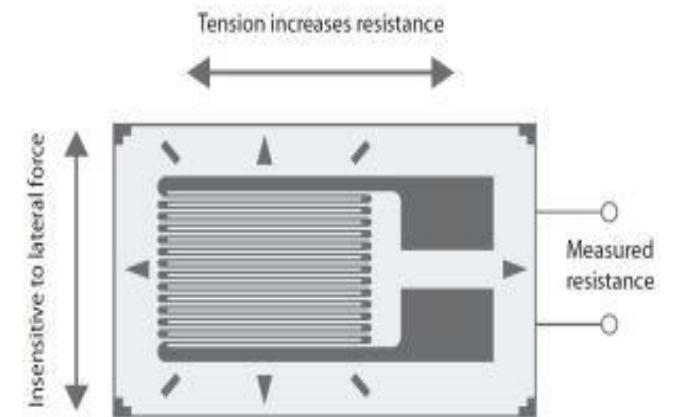

CURRENT DESIGN CONCEPT: LOAD CELL

Criteria

- Design Use
 - Top load cells
- Advantages and Disadvantages
 - Would not have to recalibrate it every time it is used
 - Inaccuracy of testing
- Choosing the Proper Load Cells
 - Can range from 5 – 500,000 lbs.

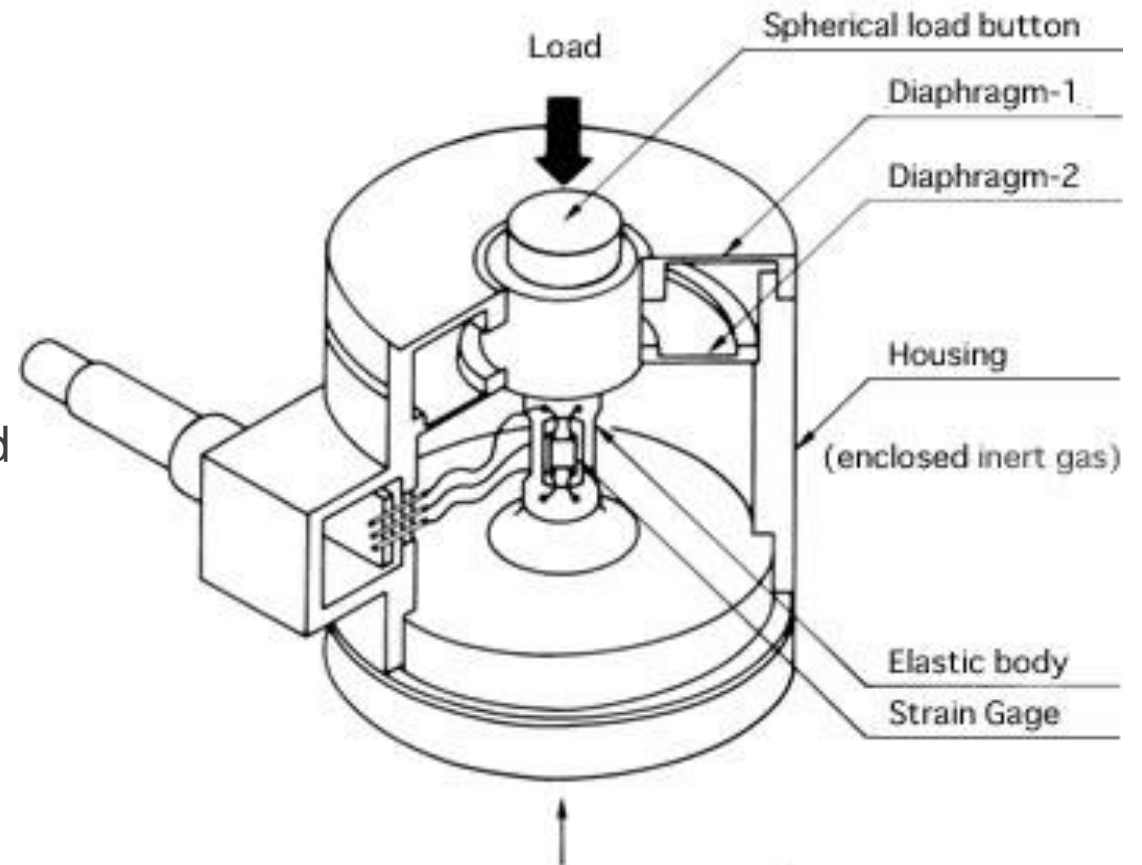

CURRENT DESIGN CONCEPT: LOAD CELL

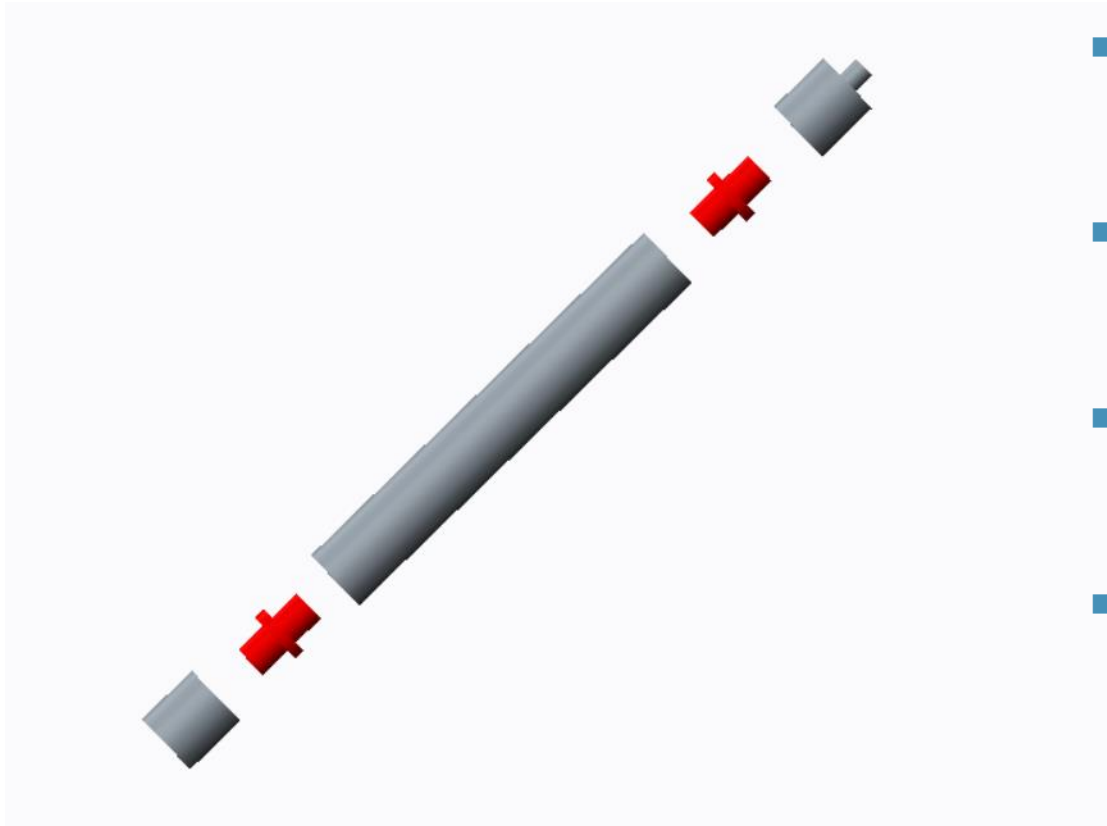

- Load Cells located at the top of shaft
- Utilizes a protective housing
- More accurate than strain gauges
- Reads out a voltage from the impact force of penetration

CURRENT DESIGN CONCEPT: STRAIN GAUGE

- Using a flexible resistive foil compacted between an adhesive material
- Wheatstone bridge allows for an accurate measure of the voltage change
- Smaller and more compact due to no protective housing of the elastic membrane

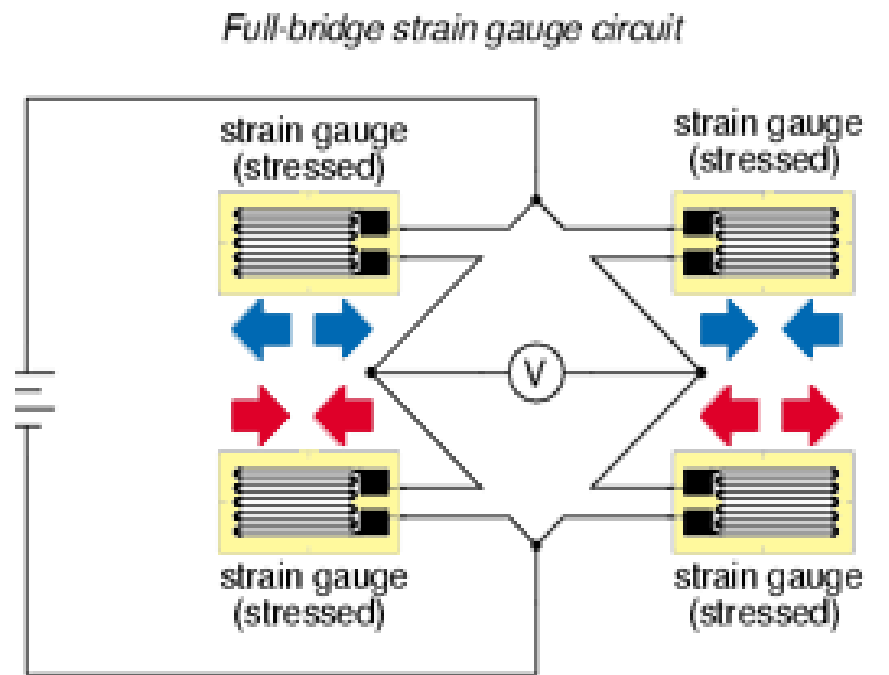

CURRENT DESIGN CONCEPT: STRAIN GAUGE

- Encased elastic membrane much like a load cell configuration
- Strain gauge directly attached to elastic material of the rod
- Impact force changes the strain gauge resistance
- Exposure to the environment while penetrating the ground

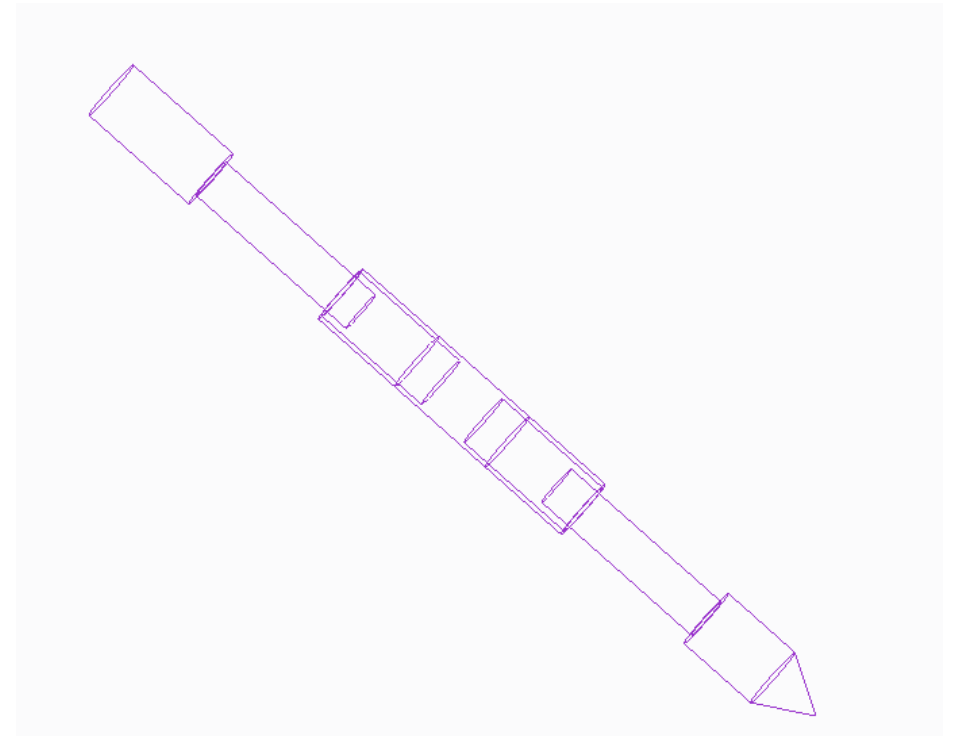

ELECTRICAL ASPECT OF DESIGN

- 10 Volt rechargeable and replaceable battery
- Bluetooth capable data acquisition module
- Bluetooth capable laser range finder
- Data will be displayed on an Android device
- Android App will be created to display and store the data

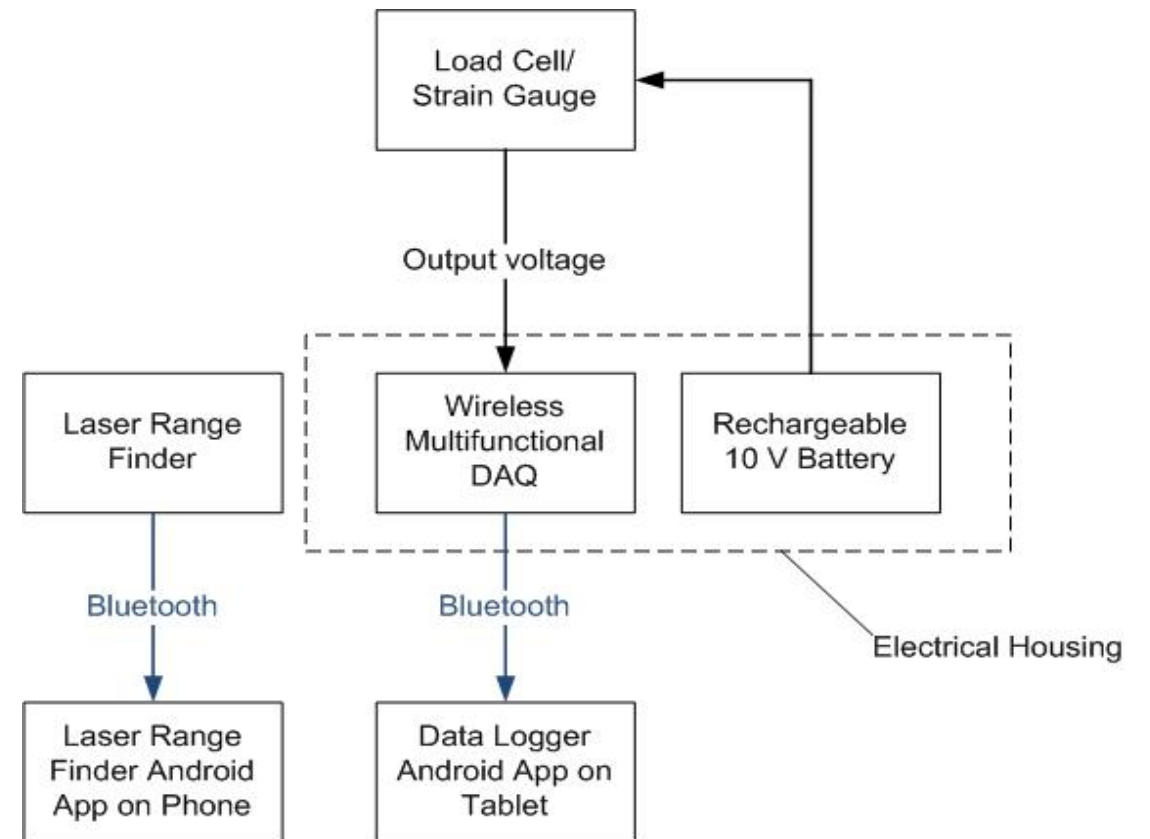

ELECTRICAL DESIGN: ARDUINO MEGA 2560 DAQ

Arduino

- Operating Voltage: 5V
- 54 Digital I/O pins
- 16 MHz clock speed
- 256 kB flash memory

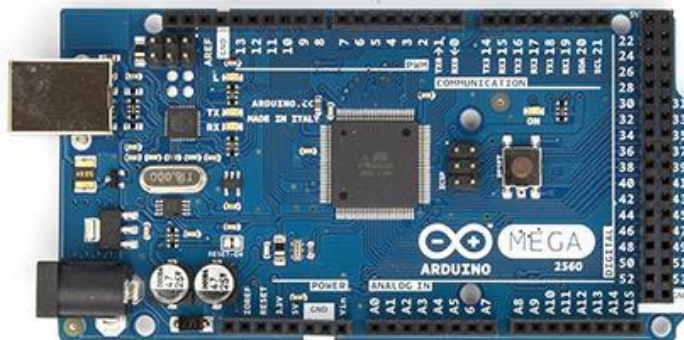

Group Number 18

Slide 11 of 17

LCD

- 1.77" diagonal, with 160 x 128 pixel resolution
- LCD screen will have to be wired to the Arduino board
- protective case will have to be made house the LCD screen



Speaker: Mitchell Robinson

Midterm Presentation II - Penetrometer

ELECTRICAL DESIGN: BTH-1208LS DAQ

- Sample rate: 1 kS/s continuous, 47 kS/s burst mode
- Battery or USB power options
- Two 12-bit analog outputs
- Eight 11-bit SE or four 12-bit DIFF analog inputs
- May require an Op-amp for better resolution



ELECTRICAL DESIGN: LASER RANGE FINDER

- Measured with laser and reference point
- Laser measures displacement of reference point
- Device records the depth and sends the data to an Android device
- Android application developed by the company, Vertek.



ELECTRICAL ASPECT: DESIGN MATRIX

		Portable/Wireless		Cost		Ease of Use		Durability		Total
Weight (%)		0.35		0.10		0.40		0.15		1.00
Designs	Wireless DAQ	Score	Total	Score	Total	Score	Total	Score	Total	8.65
		8	2.80	2	2.0	7	2.80	7	1.05	
	Arduino	Score	Total	Score	Total	Score	Total	Score	Total	5.30
		5	1.75	8	0.80	5	2.00	5	0.75	

- BTH-1208LS has the most value and will be the DAQ device used for this project

ELECTRICAL ASPECT: WHY THE BTH-1208LS?

- The BTH-1208LS won in almost every category
- DAQ is wireless Arduino is not
- An LCD screen must be attached to Arduino
- Arduino Board has no enclosure
- Enclosure would also be needed for the LCD screen
- BTH-1208LS has many Demo Apps



SUMMARY

- Extendable attachments
- Prototype design of housing
 - Load cells & strain gauges
- T-bar vs drop weight design
- BTH-1208 DAQ system
- Future orders and testing of load cells & strain gauges
- Maintain communication with the sponsor

ANY QUESTIONS?

Visit Our Website

http://eng.fsu.edu/me/senior_design/2015/team18/

