

Prototype Machine for Coating Stabilized Lithium Metal Powder



ME#16/ECE#18

Sponsor: Dr.Zheng

Team Members:

**Marcos Leon, John Magner, Vannesa Palomo,
Maria Sanchez, John Shaw, & Benjamin Tinsley**

Faculty Advisor: Dr.Gupta

Advisor: Dr.Shih

Introduction

- + Sponsor
 - + General Capacitors LLC.
- + Lithium-Ion Battery
 - + Electrochemical Functionality
 - + Rechargeable
 - + High Efficiency

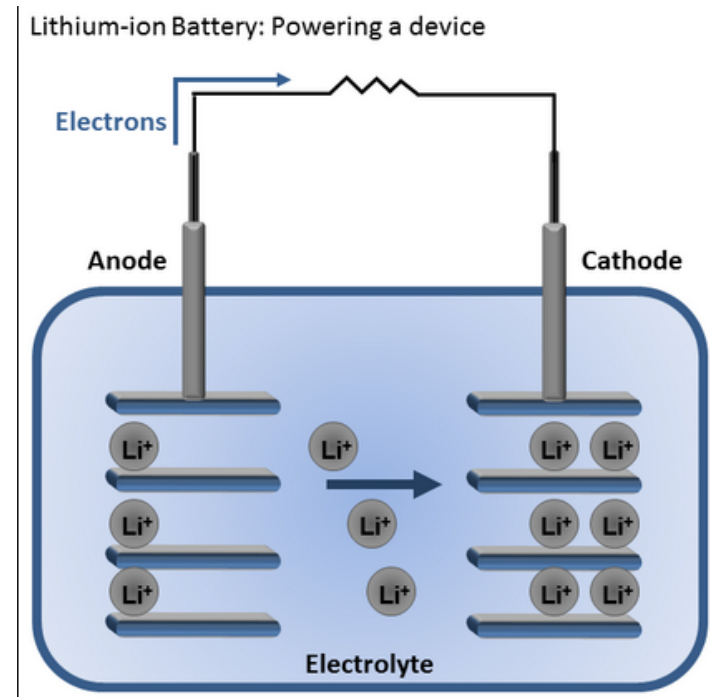

Image 1: Illustration of how Lithium Ion Batteries function.

Aim

- + To create a prototype machine that can uniformly coat stabilized lithium metal powder on an anode.



Image 2: Hard carbon electrode.



Image 3: Hard carbon electrode coated with SLMP.

Motivation

- + Purpose of Coating
 - + Used as a compensation of the irreversibility of the system
- + Benefits of Coating SLMP
 - + Increases the batteries performance by a range of 5% to 15%
 - + Increases the energy density by 2-4 times in super-capacitors.
 - + Can be applied on pre-existing anode



Background

- + Stabilized Lithium Metal Powder (SLMP)
 - + Developed by FMC Lithium
 - + Particle size: 30-60 Microns
 - + Density: 0.534g/cm²
 - + Reactivity: Flammable to ambient humidity; sensitive to air and water
 - + Dry room Condition:< 30 degree Celsius



Background

+ Current Technology Available

+ FMC Lithium

- + Method: Slurry application in which SLMP is mixed into a slurry using a volatile solvent.
- + After application of the slurry, the solvent evaporates and leaves a well distributed coat of SLMP.
- + Cost: \$ 2 million dollars

+ Tokyo Electron Limited

- + Method: Form a thin lithium film on anode sheet by melting and spraying lithium-containing powder.
- + Using argon gas to melt.
- + Cost: \$6 million dollars



Constraints

- + General Capacitors Budget: \$2,000
- + Coat total surface area of anode
- + Anode parameters:
 - + 5-12 cm (width)
 - + 5-25 cm (length)
- + Uniform layer of SLMP
 - + Thickness: 150 μm
 - + Tolerance: $\pm 20\%$
- + Coat anode within 10 minutes
- + Test SLMP coating process in a dry room
 - + AME dry room is 0.5% humidity

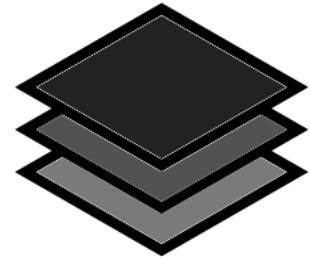

Design Approach

<u>Morphological Chart</u>	Option 1	Option 2	Option 3	Option 4	Option 5	Option 6
Powder Dispersion Method	Dry	Wet				
Application Method	Slurry	Chemical Deposition	Gas Treatment	Vacuum Molding	Sintering	Surface Application
Uniformity Mechanism	Spray	Funnel	Rotary Meter Mill	Doctor's Blade (knife)	3D printing	Meshes
Method of Vibration	DC Vibration Motors	Brushless Motor	Hydraulic Actuators	Pneumatic Actuators		
Power Supply	Battery	Power Supply				



Selection of Concepts

- + Powder Dispersion Method
 - + Dry
- + Application Method
 - + Surface Application
- + Uniformity Mechanism
 - + Meshes
- + Method of Vibration
 - + DC Vibration Motors
- + Power Source
 - + Power Supply

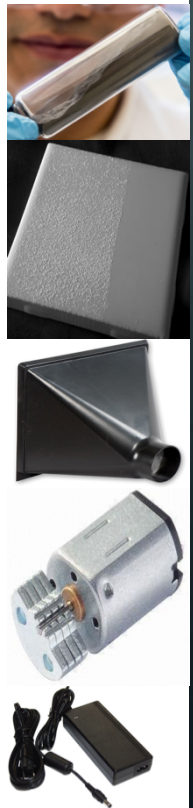

Evolution of Concept

- + Design #1:
 - + Utilized a funnel, a roller held in suspension by springs, and a punch.
 - + Reasons for change:
 - + Funnel would not keep SLMP flow constant
 - + Roller would not produce the amount of pressure needed to activate lithium.

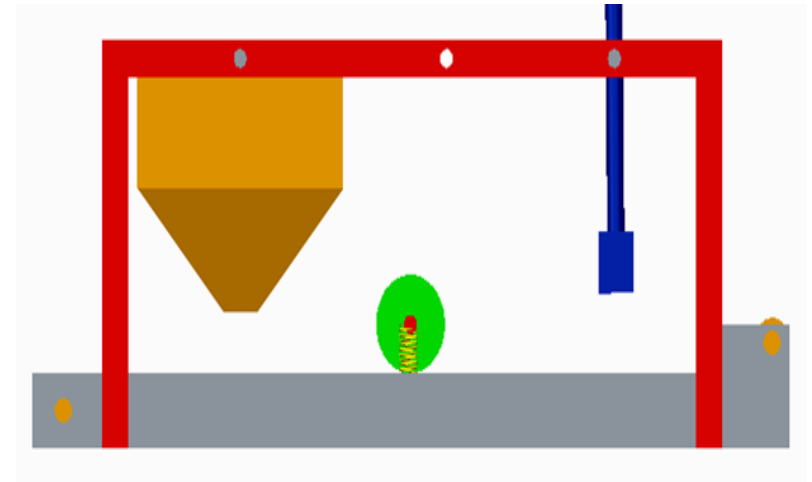

Evolution of Concept

- + Design #2:
 - + Anode is stationary, while funnel, roller, punch are moved by linear displacement.
 - + Reason for Change:
 - + Complex design which would exceed budgetary limits

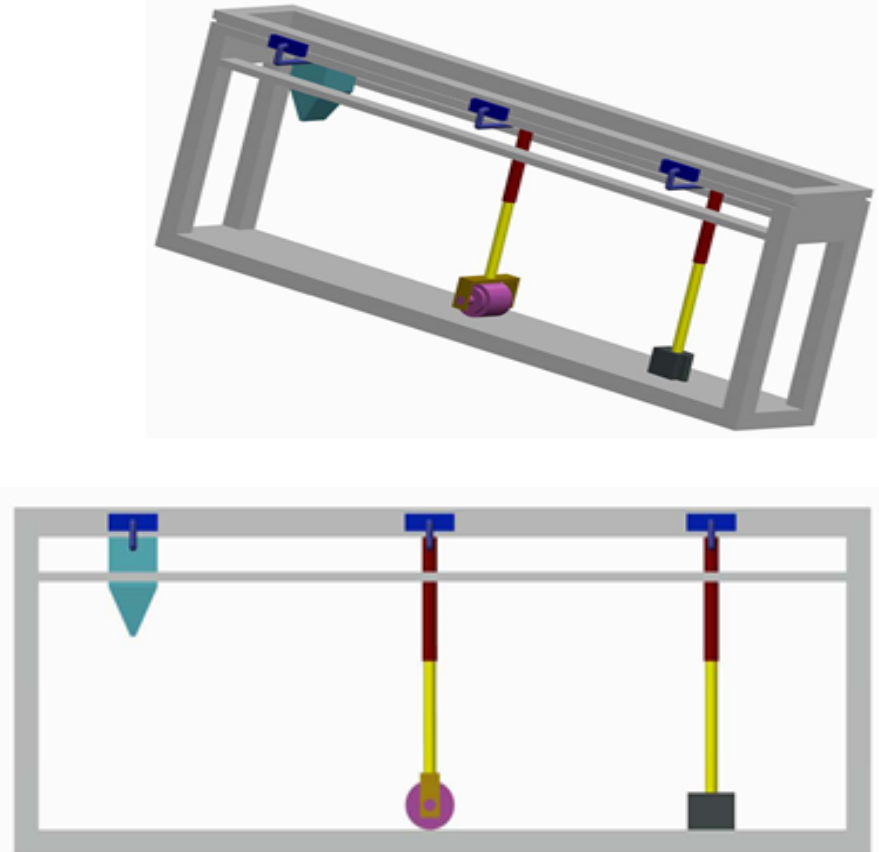

Evolution of Concept

- + Design #3:
 - + Consists of a funnel, an incline plane, and a roller held in suspension.
 - + Reasons for Change:
 - + Simplistic design did not properly control flow rate
 - + Roller did not supply the appropriate amount of pressure to activate lithium

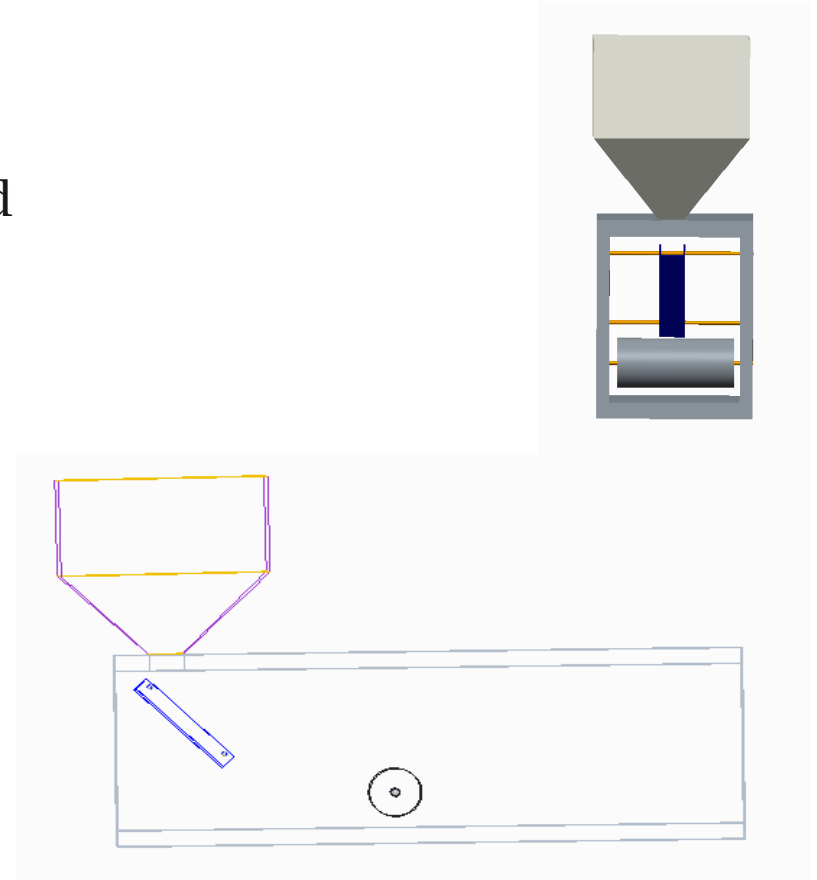

Evolution of Concept

- + Design #4:
 - + Utilizes a rotary metering roller to collect equal amounts of SLMP from a storage trough and dump it on the anode as it rotates.
- + Reason for change:
 - + Unsure if this design would improve uniformity
 - + This metered roller complicates the machine
 - + The press rollers are unnecessary since sponsor is providing a flat press.

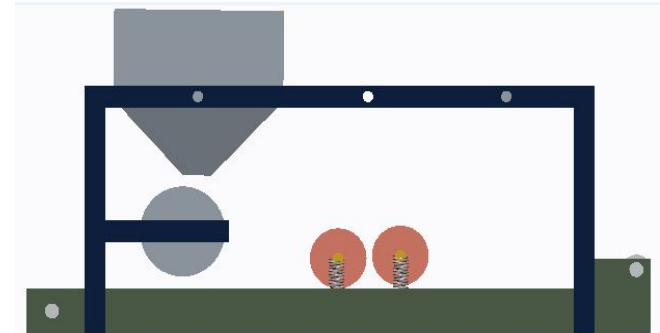
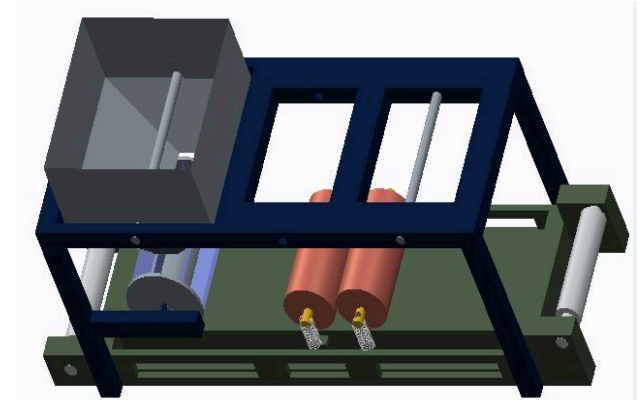

Evolution of Concept

- + Design #5:
 - + Consists of a funnel with actuators positioned around the exit, 3 layers of meshes suspended below the outlet, a conveyor belt, emergency stopper, and a plastic tray.
 - + Reason for change:
 - + Funnel would drop SLMP much too quickly on to meshes
 - + Meshes would have agglomeration in specific locations

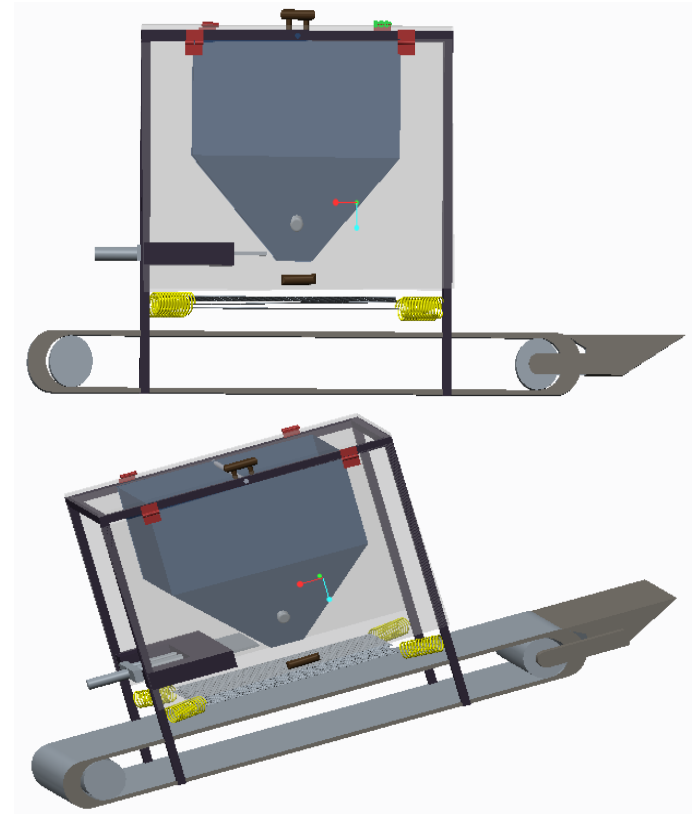

Evolution of Concept

- + Design #6
 - + Utilizes funnel with 3 mesh layers positioned throughout length, incline plane with adjustable arms, conveyor belt system, emergency stopper, and provided rolling press.
 - + Reason for Change:
 - + Could not ensure the proper degree of inclination to produce constant flow.

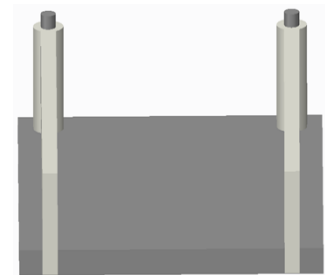
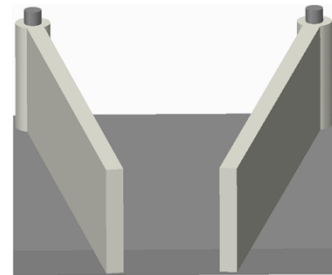
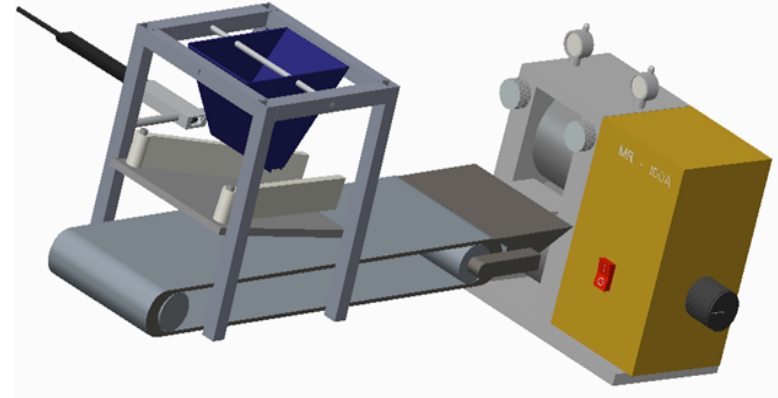

Evolution of Concept

- + Design #7
- + Selected as Final Design

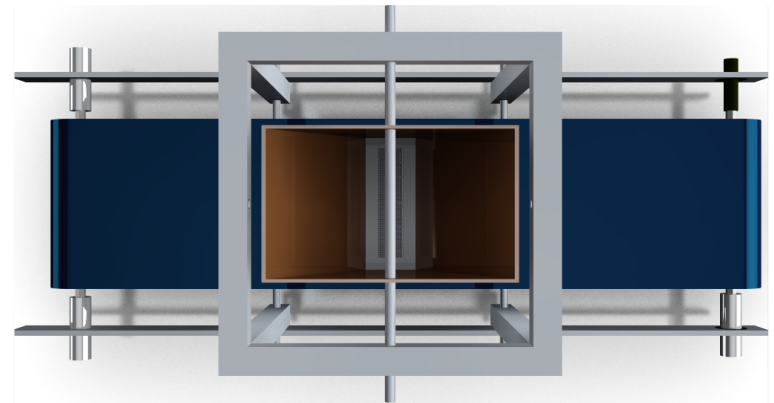
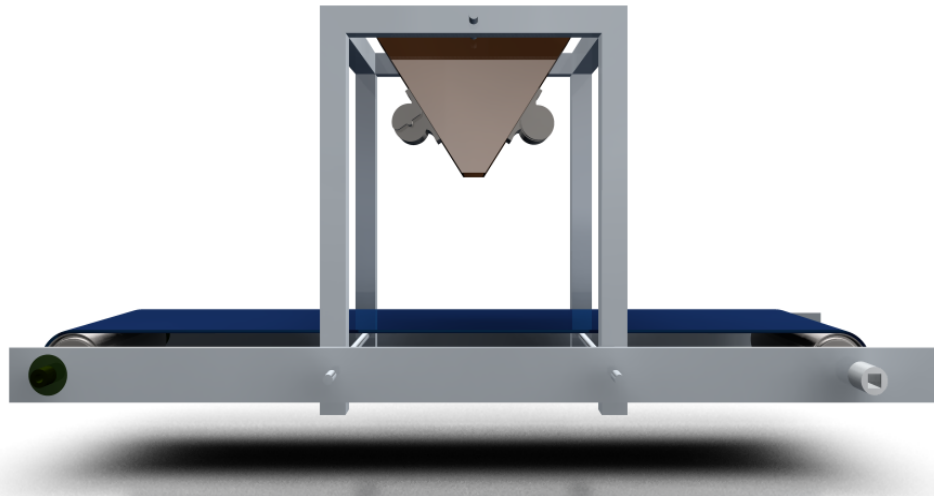

Final Design

- + Process is divided into 3 major parts
 - + Powder dispersion
 - + Powder coating
 - + Powder pressing



Image 4: Photo of Completed Prototype Machine.

Microprocessor

- MCU - Arduino Mega 2560 R3 Microcontroller
 - This MCU will be the “brains” of the operation
 - Technical Specifications
 - Input Voltage: 7-12V
 - Digital I/O Pins: 54
 - PWM Digital I/O Pins: 15
 - Flash Memory: 256 Kb
 - Clock Speed: 16 MHz

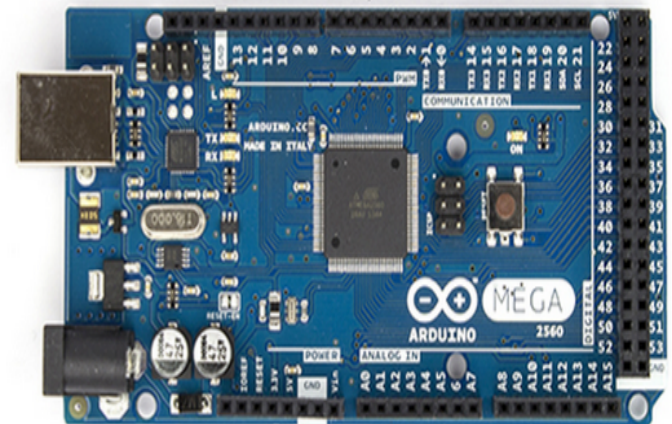

Image 5: Arduino Mega 2560 R3

Power Supply

- 120 VAC to 12V/ 5A power supply (60W)
- Output is a 2.1 mm DC plug with an inline ON/OFF switch
 - Splits into (2) 2.1 mm DC plugs
 - One powering Arduino
 - One powering Motors



Image 6: 60 W Power Supply.

Table 1: Power Consumption

Component	Nominal Voltage	Maximum Current	Power Consumed
Stepper Motor	12	1.7	20.4
(2) DC Motors	12	0.07	1.68
Cooling Fan	12	0.02	0.24
Arduino Mega	12	0.05	0.6
LCD Display	5	0.1	0.5
Total Power			23.42



Image 7: 2-Way 2.1mm DC Barrel Jack Splitter

Final Design (LCD/ Keypad)

To begin the coating process, the user will first be prompted by the 16X2 character LCD display to “Enter Length: ”

The user will then enter their desired coating length using the 3X4 numeric keypad.

When coating is finished the LCD will prompt the user to press any button, returning the conveyor belt to its original position.

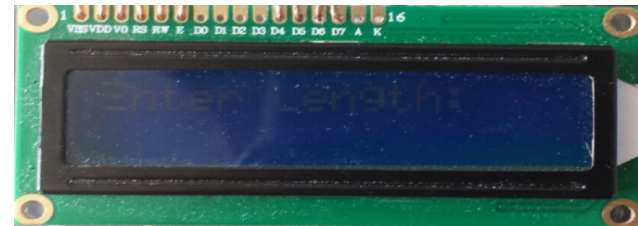

Image 8: LCD “Enter Length”

Table 2: Keypad Options

Key Pressed	Result
*	Re-enter Length
#	Select Length
Value < 5 or > 25	Invalid Length: Re-enter Length
Value > 5 and < 25	Begin Coating Process

Final Design (Funnel and Meshes)

- + Once the length have been entered the user will pour SLMP into the funnel
- + The SLMP will flow through the funnel until it comes in contact with a 104.14 microns open diameter mesh.
 - + Mesh is placed across the funnel to limit flow.
- + 2 DC vibration motors will be used to vibrate the meshes and facilitate the flow of the SLMP producing a uniform particle distribution.

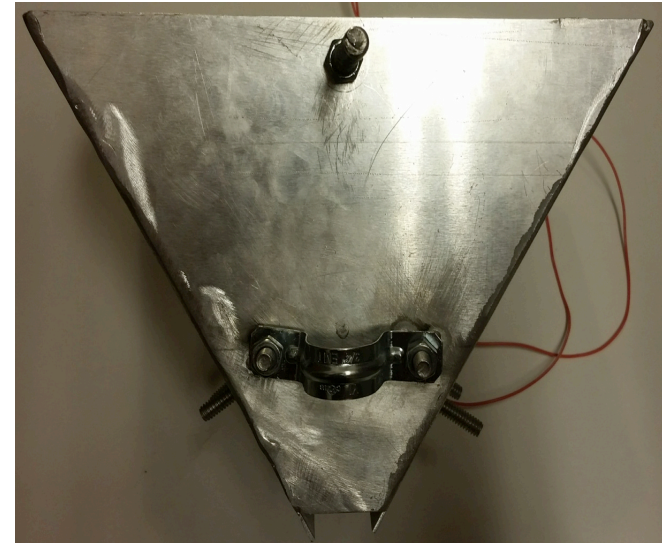

Image 9: Photo of Aluminum funnel fabricated.

DC Vibrating Motors

DC Vibrating Motors

- When the dispersion process begins (2) DC vibrating motors will be turned on to vibrate the funnel and meshes.
- Ensuring a steady flow by:
 - Attaching the DC motors to the outside of the funnel, thus vibrating the entire funnel as a whole.

Table 3. Specifications of the motors utilized in prototype.

Motor	Voltage	RPM
DC off-set mass Vibration Motors	12	4,000 RPM



Final Design (Conveyor/ Rollers)

- Directly beneath the outlet of the funnel, an anode will be placed on the conveyor belt waiting to be coated.
- The Conveyor belt is 84 centimeters long belt made of recycled tire rubber and other natural rubbers.
- There are two rollers that will hold the conveyor belt in tension:
 - One is the driver which is connected to the stepper motor by a 3D printed hexagonal adaptor.
 - The other is free turning to allow for resistance free rotation.

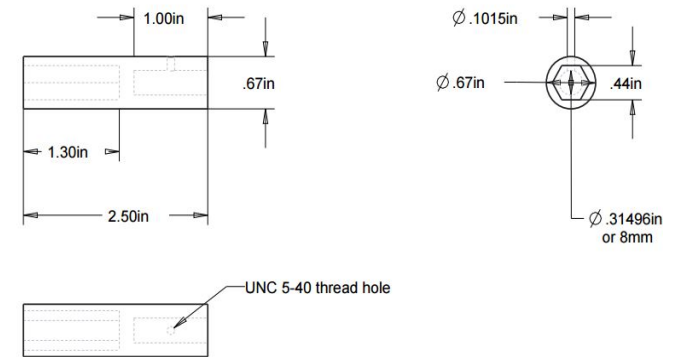

Image 10. Technical drawing of the hexagonal adaptor.



Image 11. Photo of the roller used, purchase from Grainger Industrial Supplier.

Final Design (Conveyor Motor)

A 12V, 1.68A, 416 oz-in bipolar stepper motor is used to drive the conveyor belt.

- There is a set distance from start to funnel and from funnel to end.
- While the anode is under the funnel the conveyor belt will go back and forward 5 times.

Steps for a given length is calculated accordingly:

- The rollers circumference is 15.16 cm
- The motor has 5373 steps per revolution.
- Circumference = $\pi \cdot d$
- # of Steps = $(\text{Steps/Revolution}) / (\text{Circumference}/\text{Input})$

A DRV8825 motor driver is used to control the stepper motor

- Rated up to 2.2A with a heatsink and cooling fan.

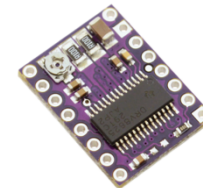

Image 12.
Photo of
the motor
driver.

DRV8825

Table 4: Length to Step Conversions.

Input (mm)	# of Steps
50	1684
60	2021
70	2358
80	2695
90	3032
100	3368
110	3705
120	4042
130	4379
140	4716
150	5053
160	5390
170	5726
180	6063
190	6400
200	6737
210	7074
220	7411
230	7748
240	8084
250	8421



Design of Experiment

+ The appropriate mesh sizes were selected using empirical calculations.

+ Mesh Count Calculations:

$$PS = \frac{1}{MC} + tw$$

$$MC \leq \frac{1}{PS - tw}$$

MC = Mesh Count
tw = thickness of wire

Mesh count $\geq 16.67^*$

*Assuming Particle Size = 50 micrometer

Wire thickness ≥ 0.01 mm



Initial Experimentation

+ Meshes

- + Hypothesis: Increase in number meshes would reduce agglomeration and increase flow rate
- + Initial testing method:
 - + Meshes are used to sift the SLMP and disperse it onto the anode
 - + Observations
 - + Impede agglomeration of particles
 - + Ensure a constant flow rate

Table 5. Specification of Meshes used in initial experiment.

Mesh	Wire Thickness	Mesh Count	% Open Area
Mesh #1	60 micrometers	250	36.0%
Mesh # 2	73.66 micrometers	200	33.6%
Mesh # 3	104.14 micrometers	150	37.9%



Initial Experimentation

- + Actuators: Brushless Pico-vibe
 - + Hypothesis: Pico-vibe Actuators are positioned to cover more surface area, thus produce more vibration.
 - + Specifications
 - + 10 mm diameter
 - + Operates at 3V & 65 mA
 - + Normalized amplitude 1.4 G



Initial Experimentation

- + Initial testing method:
 - Observation of simulation material flow .
 - Time duration of observation 1 minute.
- + Results:
 - Powder flow was observed to be negligible.
- + Implementation Based on Results:
 - Not Implemented in Final Design**



Design of Experiment

+ Conveyor Belt System

+ Purpose:

- + Must be able to move the anode without disturbance
- + Must move the anode to accurately to coat the anode 5 times.

+ Parameters of Testing:

- + Pre-coated anode will be utilized
- + Specified initial and final position
- + Program must be completely executed



Initial Experimentation

+ Conveyor Belt System

- + Hypothesis: Conveyor belt will move the anode in a fluid and concise motion.

Table 6. Data collection from experiment #1 of Conveyor Belt System

Stepper Motor Tested	Trail number	Observed Status of Coating	Experimental Validation(Y/N/M)	Additional Comments
12 V- 350mA-Stepper Motor- 28 oz-in	1	Dislocated	N	Conveyor belt continuously slipped No lateral displacement
	2	Dislocated		
	3	Dislocated		
12 V-0.68 A- Stepper Motor- 125Oz-in	1	Dislocated	M	Produced displacement -unable to withstand loading torque
	2	No change		
	3	Dislocated		
12 V- 1.7 A, 416 oz-in Geared Bipolar Stepper Motor	1	No change	Y	
	2	No change		
	3	No change		



Final Experiment of Conveyor Belt System

- To confirm initial findings

Table7. Data collection from final experiment of conveyor belt system.

Stepper Motor	Number of Trial	Number of Passes	Initial Weight	Final Weight
12 V- 1.7 A, 416 oz-in Geared Bipolar Stepper Motor	1	1- 25cm	24.20 grams	24.20 grams
	2	2- 15cm	7.54 grams	7.53grams
	3	3- 15cm	2.10 grams	2.10 grams
	4	4-25cm	18.76 grams	18.75 grams
	5	5-15cm	10.99 grams	10.99 grams



Initial Experimentation: Data Analysis

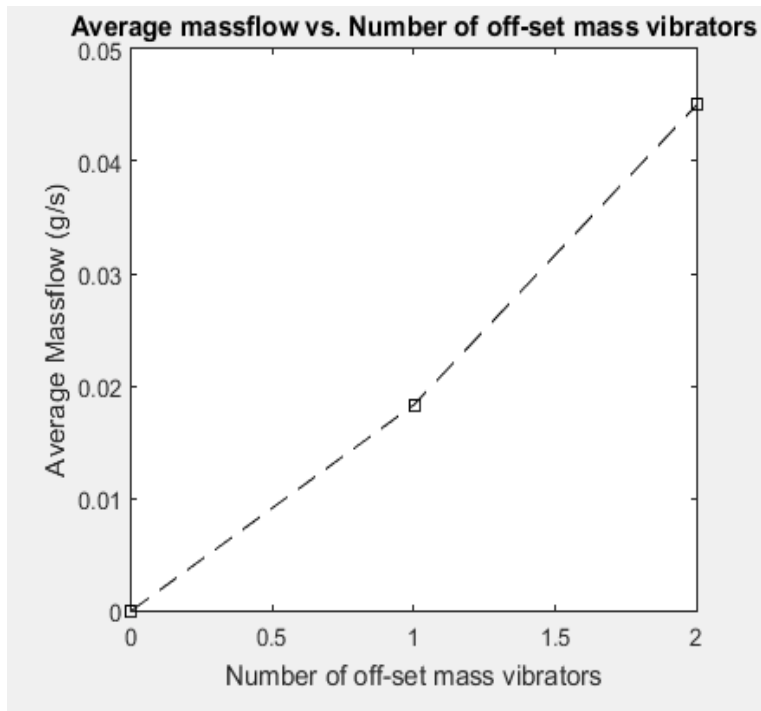

Image 13. Graph depicting the data collection from experiment #1 that determined the number of vibrational motors.

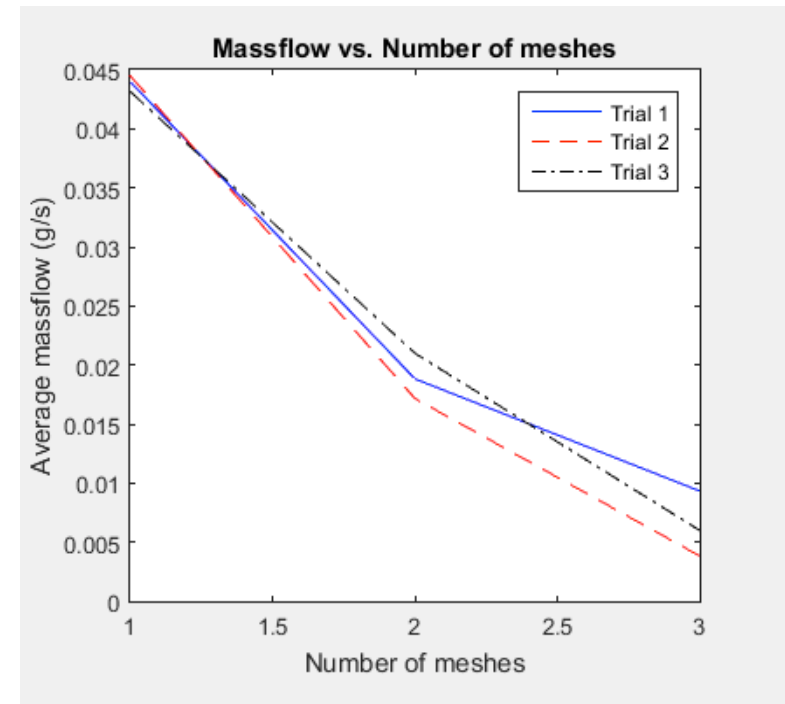

Image 14. Graph depicting the data collection from experiment #1 that determined the optimum number meshes based on flow rate.

Design of Experiment

- + Prototype
 - + Purpose
 - + To test if the prototype will coat within 10 minutes
 - + To test for appropriate meshes
 - + To determine greatest flow rate induced by various vibrators.
 - + Parameters of Test:
 - + Testing medium: Confectioner Sugar
 - + Testing Meshes
 - + Range: 1 cmx 1cm- 73.6 microns
 - + 1 minute time limit
 - + Entire program must be executed



Final Experimentation

Table 8. Data collected from final experiment of prototype outlining the variables set during experiment.

Motors Utilized	Experiment Number	Meshes Utilized	Medium Tested	Weight of Material Loaded (g)	Weight of Material Coated (g)	Time Elapsed for Completion	Mass Flow Rate (g/s)
Geared Bipolar Stepper Motor	1	1 cm x 1 cm	Confectioners sugar	15.76	11.22	1 min	0.187
	2	1 cm x 1 cm	Confectioners sugar	15.83	8.92	1 min	0.148666667
	3	1 cm x 1 cm	Confectioners sugar	15.92	10.51	1 min	0.175166667



Data Analysis of Final Experiment

Mass Flow Rate of Testing Medium

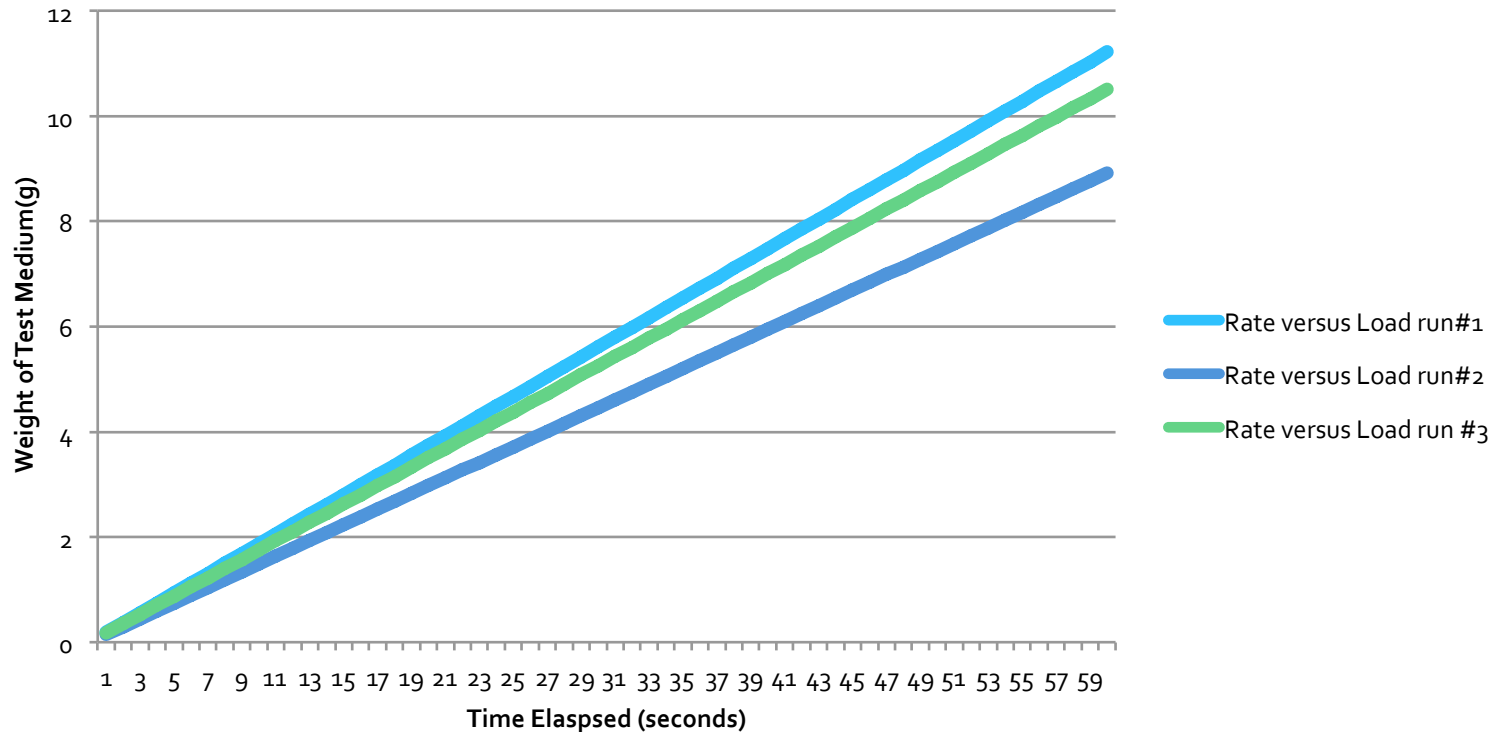

Data Analysis of Final Experiment

Correlation of Mass Flow and Percentage of Coating per Trail

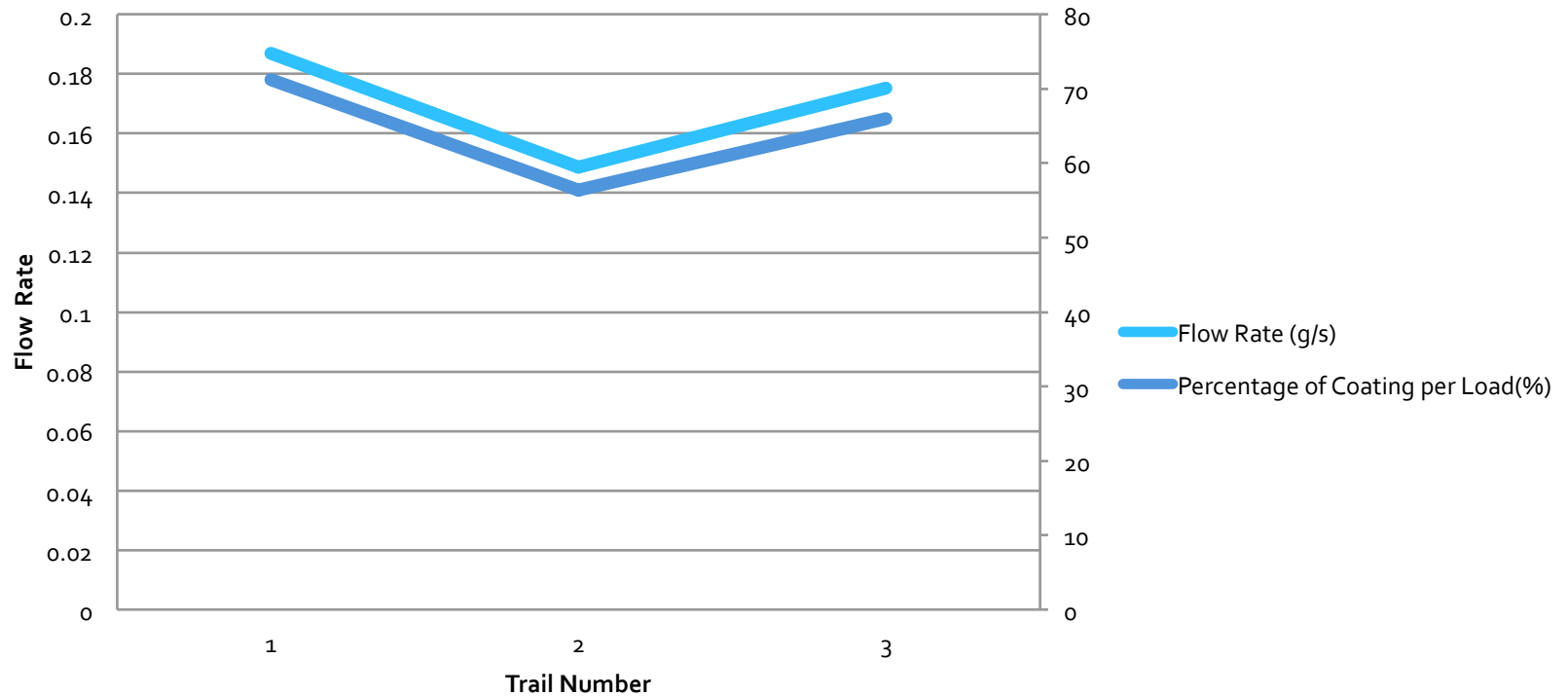

Results

- + Final Experiment Confirmed:
 - + Single Mesh inside of the funnel
 - + Two offset mass vibration actuators applied to walls of funnel

Table 9. The average flow rate of all trial runs of the final and average percentage per trail.

Average Mass Flow Rate	Average Percentage of Coating per Trial
0.17 grams/ second	64.52%



Budget Overview

Status of Budget

14%
\$277.88

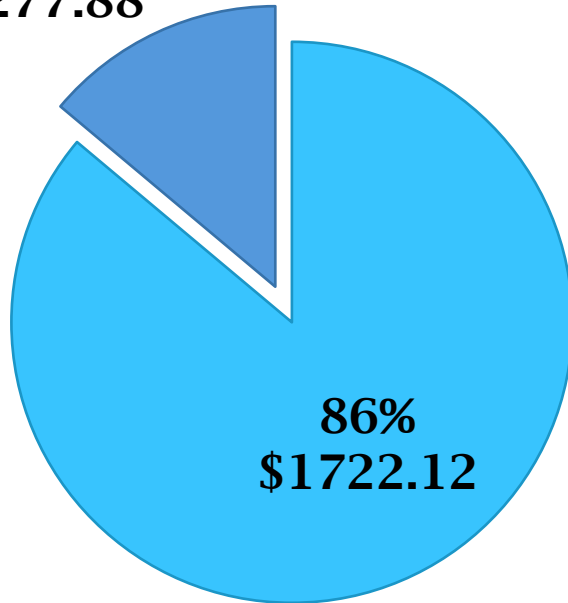

Total Budget:
\$2,000 USD



Budget Overview

Budget Distribution by Fabrication Cost

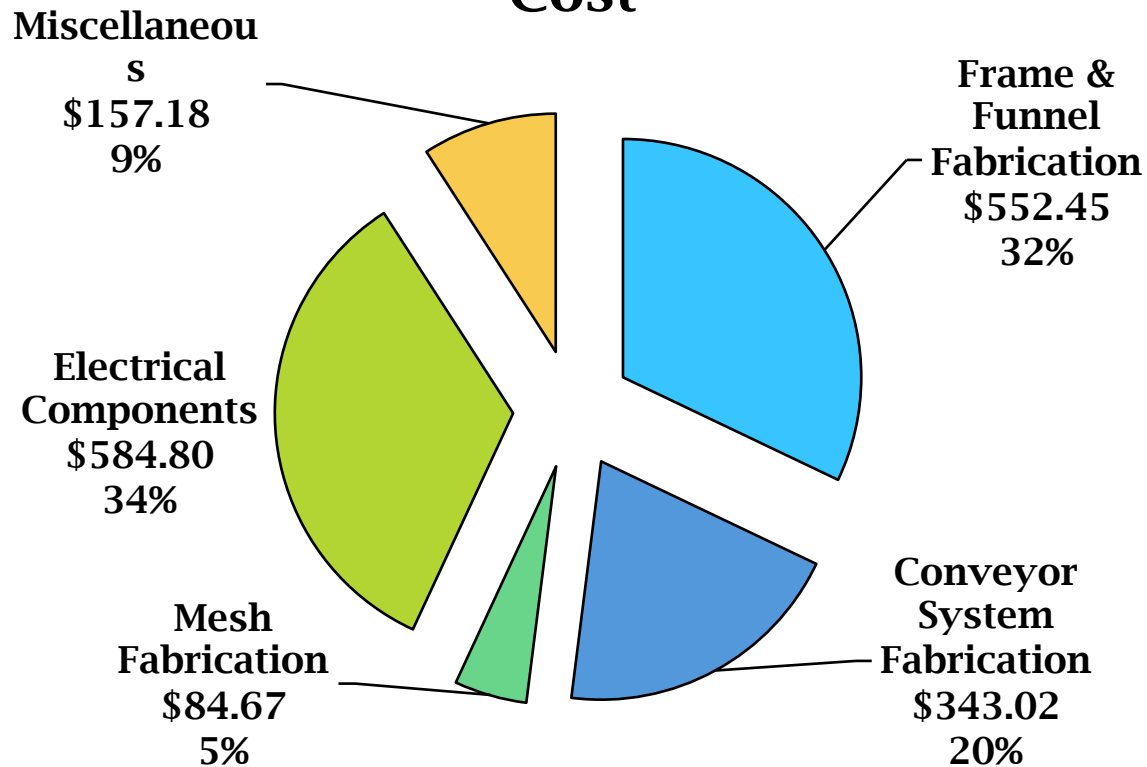

Resource Allocation

Hours Per Team Member

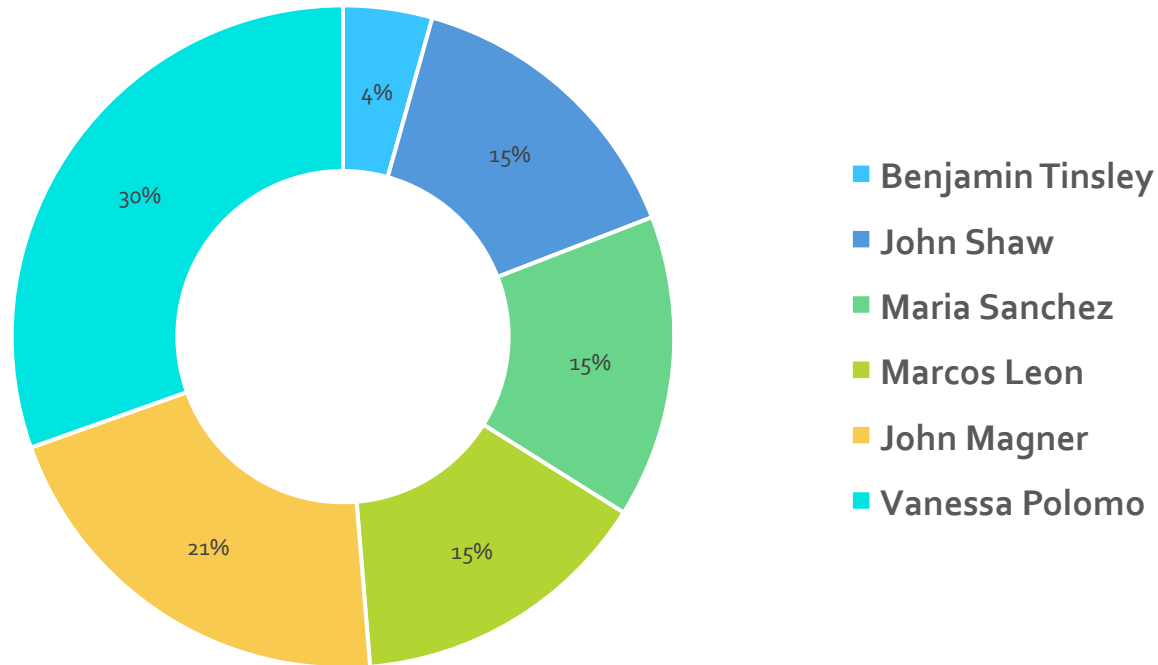

Schedule

	Task Name	Duration	Start	Finish
1	Research SLMP	14 days	Mon 9/8/14	Thu 9/25/14
2	Research Coating Techniques	14 days	Fri 9/26/14	Wed 10/15/14
3	Desinging of 3 Initial Designs	21 days	Wed 10/15/14	Wed 11/12/14
4	Selection of Optimum Design	2 days	Mon 11/17/14	Tue 11/18/14
5	Optimize Chosen Design #4 Design	10 days	Tue 11/18/14	Mon 12/1/14
6	Conduct FEM Analysis on Design #4	5 days	Tue 12/2/14	Mon 12/8/14
7	Winter Break	17 days	Fri 12/12/14	Mon 1/5/15
8	Revize Design #4	5 days	Mon 1/5/15	Fri 1/9/15
9	Optimize New Design - Design #5	7 days	Fri 1/9/15	Mon 1/19/15
10	Finalize Design #5	5 days	Mon 1/19/15	Fri 1/23/15
11	Make Bill of Materials	3 days	Wed 1/21/15	Fri 1/23/15
12	Ordering Parts from Grainger and Time to Receive(TOR)	21 days	Fri 1/23/15	Fri 2/20/15
13	Construction of Wooden Test Frame	2 days	Fri 1/23/15	Mon 1/26/15
14	Perform FEM Analysis on Parts of Design #5	3 days	Sat 1/24/15	Tue 1/27/15
15	Testing of Meshes on Wood Frame	5 days	Mon 1/26/15	Fri 1/30/15
16	Manufactoring of Tower and Funnel and TOR	5 days	Sat 1/31/15	Thu 2/5/15
17	Ordering of Home Depot Parts Through AME and TOR	15 days	Tue 2/3/15	Mon 2/23/15
18	Ordering of Electronic Parts Through AME and TOR	10 days	Wed 2/4/15	Tue 2/17/15
19	Manufactoring of Conveyor Belt Adapter and TOR	5 days	Sun 2/8/15	Thu 2/12/15
20	Manufactoring of Conveyor Bars and TOR	3 days	Mon 2/9/15	Wed 2/11/15
21	Program Arduino Board With Motor	10 days	Tue 2/17/15	Mon 3/2/15
22	Assemble Meshes to Mesh Framing at Varying Sizes	3 days	Wed 2/25/15	Fri 2/27/15
23	Attach Funnel to Tower	2 days	Tue 3/3/15	Wed 3/4/15
24	Attach Actuators to Funnel	2 days	Wed 3/4/15	Thu 3/5/15
25	Spring Break	5 days	Mon 3/9/15	Fri 3/13/15
26	Test Meshes Inside Funnel with Actuator Assist	7 days	Mon 3/16/15	Tue 3/24/15
27	Order More Powerful Actuators and TOR	5 days	Tue 3/24/15	Mon 3/30/15
28	Construct Conveyor Belt	5 days	Wed 3/25/15	Tue 3/31/15
29	Manufacturer New Modified Coveyor Belt Adapter and TOR	3 days	Fri 3/27/15	Tue 3/31/15
30	Order New Motor and Conveyor Belt and TOR	5 days	Thu 3/26/15	Wed 4/1/15
31	Test Meshes Inside Funnel with Actuator Assist P2	7 days	Thu 4/2/15	Fri 4/10/15
32	Reconstruct Conveyor Belt	3 days	Thu 4/2/15	Mon 4/6/15
33	Finalize Bill of Materials Included in Construction	2 days	Sat 4/4/15	Mon 4/6/15
34	Test Completed Prototye	9 days	Mon 4/6/15	Thu 4/16/15
35	Analysis of Coating	5 days	Sat 4/11/15	Thu 4/16/15

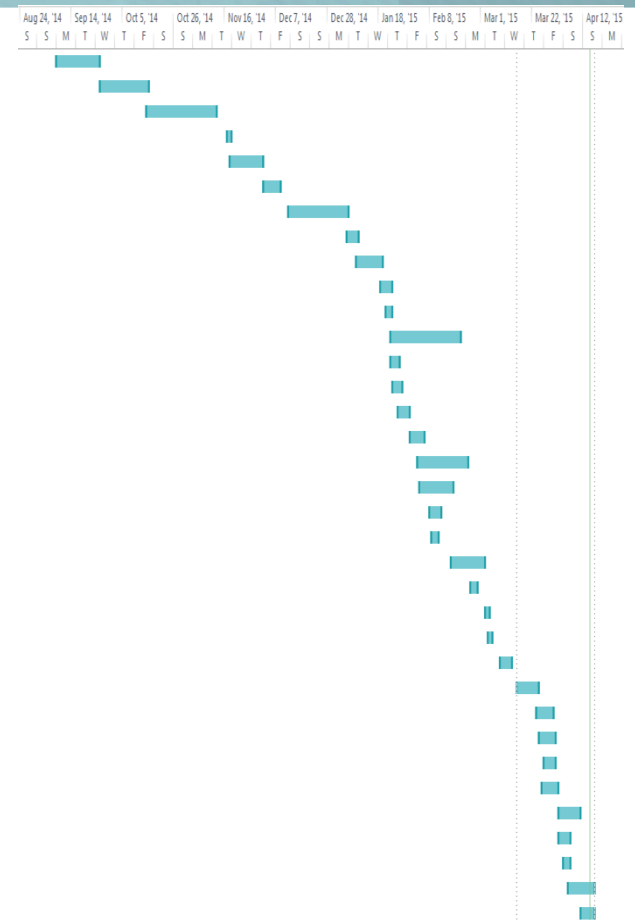

Conclusion

- + The purpose of the presented project was to address the constraints for our SLMP prototype machine.
 - + Anode coating was accomplished within 10 minute period
 - + Vibration flow was achieved, consistent with results
 - + Uniform coating during experimentation was observed
 - + Semi-automat functions were established, via electrical components
 - + User interface allows for various anode length input



Lessons Learned

- + Keep the testing atmosphere as clean and consistent as possible
- + When making purchases buy additional parts that have a probability of failure
- + Always allow for additional time for the procurement process
- + Timeline estimations should always be doubled
 - + Everything will take longer than you expect it to
- + Test Test and Test Some More
 - + It is important to frequently troubleshoot all aspects of the design. Every design has flaws and it is important to find/address them.



Future Recommendation

- + Addition of a stabilizing base plate as foundation for entire prototype
- + Experimentation with different funnel material and support rod material
- + Exploration of linear vibrational methods rather than vertical displacements
- + Addition of positioning and weight sensors



Questions/Comments



