

# Stabilized Lithium Metal Powder Coating Machine: Project Plan and Product Specs

---

Team Number: 16

Submission Date: October 10, 2014

Submitted To: Mechanical Engineering Department

Authors:

Marcos Leon	ml10s
Vannesa Palomo	vp09
John Shaw	jcs09e
Maria Sanchez	ms13
John Magner	jjm10n
Ben 'Bj' Tinsley	bjt11

## Table of Contents

<b>Abstract</b> .....	<b>2</b>
<b>1 Introduction</b> .....	<b>3</b>
<b>2 Project Definition</b> .....	<b>4</b>
<b>2.1 Background research</b> .....	<b>4</b>
<b>2.2 Need Statement</b> .....	<b>5</b>
<b>2.3 Goal Statement &amp; Objectives</b> .....	<b>6</b>
<b>3 Constraints</b> .....	<b>7</b>
<b>3.1 Design Specifications</b> .....	<b>7</b>
3.1.1 Overall System.....	8
3.1.2 Base.....	9
3.1.3 Funnel .....	10
3.1.4 Mesh.....	11
3.1.5 Roller vs Half-roller .....	11
3.1.6 Rectangular punch.....	13
<b>3.2 Performance Specification</b> .....	<b>13</b>
<b>4 Methodology</b> .....	<b>16</b>
<b>4.1 Schedule</b> .....	<b>16</b>
<b>4.2 Resource Allocation</b> .....	<b>20</b>
<b>5 Conclusion</b> .....	<b>24</b>
<b>6 References</b> .....	<b>25</b>

## Table of Figures

Figure2-1.Evaportation process.....	2
Figure 2-2. First Cycle Efficiency Improvement Using SLMP.....	3
Figure 3-1. Side view .....	9
Figure 3-2. Front view .....	9
Figure 3-3. Top view .....	9

Figure 3-4. Side view .....9  
Figure 3-5. Front view .....9  
Figure 3-6. Top view .....9  
Figure 3-7. Base of coating machine .....11  
Figure 3-8. Circular with small outlet .....11  
Figure 3-9. Square with small outlet .....11  
Figure 3-10. Circular with large outlet.....12  
Figure 3-11 Square with large outlet .....12  
Figure 3-12 Mesh shapes, size, and material differences .....13  
Figure 3-13. Half-roller .....13  
Figure 3-14. Roller .....13  
Figure 3-15. Punch to make Specific sized anodes. ....15  
Figure 3-16. Laser Scanner .....16  
Figure 3-17 MICROTRAK PRO 2-D Performance Specifications .....16  
Figure 4-1. Gantt chart for the SLMP project. ....19  
Figure 4-2. Work breakdown structure. ....20,21

## Table of Tables

Table 3-1.Laser Scanner Specifications..... 16  
Table 4-1. Resource Allocation Table. .... 22,23,24,25

### Abstract

The design process of this project allows for the realization of a user interface coating machine that adheres Stabilized Lithium Metal Powder (SLMP) to an electrode. The process is described subsequently to address the problem statement, scope, objectives, and the overall methodology. The overall plan includes project constraints, deliverables, allocated resources, and design/performance specifications. Using a dry method of application, the SLMP will be dropped onto the electrode material using a combination of vibration, meshes, and funnel nozzles to uniformly coat the copper electrode. The conveyor belt system will include a roller or half-roller design to press the SLMP onto the copper sheet. A rectangular punch, of varying size, will be implemented to cut out the shape of the electrode. Performance specifications set the foundation on how the process will be implemented the components necessary for functionality. The electrical components necessary to run the various motors, sensors, rollers and other control devices off a 12V power source. A high speed laser sensor will be used to test and control for uniformity of the coating of the SLM onto the electrode. The project timeline addresses the milestones and tasks per time distribution and individual performance.

## 1 Introduction

The objective of this project is to develop SLMP coated anode electrodes. In addition, the investigation of other components in Li-ion batteries and Li-ion super-capacitors will be conducted. These components include conventional carbons (e.g. graphite and hard carbon) and the high specific capacity silicon (Si) and other alloys. A prototype machine that can uniformly coat SLMP on a flat battery electrode is to be developed. The stabilized lithium metal powder (SLMP) is a relatively new product created by FMC. According to the Safety Data Sheet for SLMP, exposure to elevated temperatures above the melting point (180.5°C/357°F) can result in spontaneous ignition when it comes in contact with humid air. The main application of this metal powder is to be used in existing lithium ion batteries. The methodology improves the capacity of the Li-ion battery by 5 to 15%. Another application of the SLMP is in Li-ion super-capacitor to improve the energy density by 2-4 times.

In order to achieve these specifications effectively, the SLMP should be coated on the anode electrode uniformly. One specification that will be met includes, semi-automatically coating a flat battery electrode with the SLMPs. More specifically, the range for the loading of the SLMPs should be  $\sim 0.5-3 \text{ mg/cm}^2$ . The uniformity of the coating should be expected to be better than 20% and the coating area of the electrode is variable from 5-12 cm (width) and 5-250 cm (length). The coating time process is expected to be less than  $\sim 10$  minutes. The hardware for the coating machine is expected to be within a \$2,000.00 budget, to furnish the machine with motor, stainless steel plates and rods for the frame.

## 2 Project Definition

### 2.1 Background research

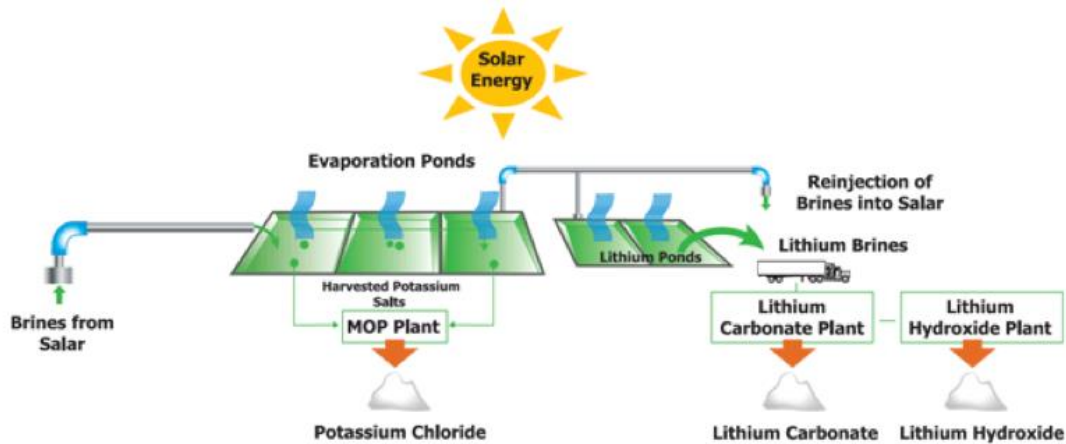

Figure 2-1. Evaporation Process for Extracting Lithium

Lithium is a highly reactive and flammable alkali metal. It is the lightest metal and 2<sup>nd</sup> least dense element. Lithium will typically react with moisture in the air and corrode, as a consequence it is usually stored in mineral oil. Lithium is not found freely due to its high bonding potential. Instead it is typically found in compounds, minerals, and ocean water. Its high solubility makes the ocean an abundant source of lithium and it can be obtained from brines and clays. Extracting lithium is relatively simple and cost effective, primarily relying on evaporation. A detailed synopsis of the process can be found on Figure 1. Lithium compounds are used in various applications, namely, high strength-to-weight alloys, ceramics, and battery cations. Lithium has a melting point of 453.65K (356.90 degrees Fahrenheit), thermal expansion coefficient of 46 (at 298K), thermal conductivity of 84.8 $\mu$ m/(m\*K), and an electrical resistivity of 92.8 n $\Omega$ \*m (at 293K). At low temperatures ( $T < 70$ K) lithium incurs diffusion less phase change transformations. Lithium has the highest specific heat capacity of any solid element of 3.58kJ/(kg\*K).

The goal of our senior design project is to make a machine that will uniformly coat a layer of stabilized lithium metal powder (SLMP) on the flat electrodes of flat Lithium-Ion batteries. This SLMP product was developed by FMC and when properly applied to the electrodes it can increase the batteries capacity by 5 to 15% and the energy density by 2 to 4

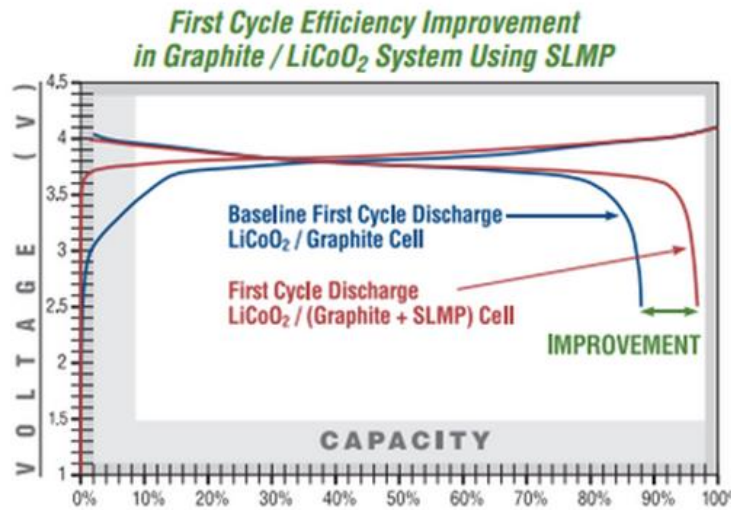

Figure 2-2. First Cycle Efficiency Improvement Using SLMP [1]

times [1]. By coating the electrodes with Lithium instead of conventional compound consisting of other compounds is the reason why these are projected to increase so highly. The capability to store more energy allows for batteries to be smaller than before but still output the same amount of energy. In addition to the extended output and longer life for batteries this stabilized lithium metal powder also greatly reduces the risks that were previously associated with

Lithium. The stability allows for the powder to be shipped and handled conventionally reducing initial costs. Now giving more possibilities for the application process such as spraying the product or applying it through a slurry. SLMP is also not pyrophoric like other forms of lithium meaning that there is not a danger of spontaneous combustion if not handled properly. Another way that costs are reduced is that the stabilized lithium metal powder can be used with non-lithiated cathodes allowing for lower cost cathodes to be used. Everyday equipment such as hybrid cars are big beneficiaries of this product due to the increase in energy capability which would allow for electric vehicles travel further with more power.

## 2.2 Need Statement

Group 16 is sponsored by General Capacitors, which is located in Tallahassee, FL. The sponsor is Harry Chen, the chief technology officer at General Capacitor LLC., However our main liaison and advisor is Dr. Zheng whom is their top research engineer and professor at FSU. The current project calls for group 16 to develop a coating machine. This machine will apply a

uniform layer of stabilized lithium metal powder to the anode electrode of a Li-ion battery and to a Li-ion super-capacitor. This material and process application is newly developed. So group 16 is researching and developing a mechanism that can be scaled up to a production level. There are other coating machines on the marketplace, however none for this specific type of application. Due to the hazardous nature of the lithium metal powder, group 16 will develop a safe and productive way to meet our mechanisms requirements.

**“A coating machine for this specific application is non existent”**

### 2.3 Goal Statement & Objectives

Goal Statement:

**“To develop an electrode with a uniform coating of stabilized lithium metal powder.”**

Objectives:

- Uniformity of roughly 20%
- Ability to apply a sufficient coat onto the electrode
- Ability to apply a coat in less than 10 minutes
- Coating must be applicable to electrodes of varying sizes.
- The process must be semi-automatic

Our goal is to develop an electrode that has a uniform coating of stabilized lithium metal powder. To execute this process, our intent is to design a prototype machine that will handle the lithium metal powder safely while applying a coat of specified thickness to the surface of a metal sheet that will later be cut to be made into an anode.



### 3 Constraints

- The budget given by General Capacitors is \$2000
- The lithium powder is to cover the total surface area of the flat battery's anode
  - The area will be varied from 5-12 cm (width) and 5-250 cm (length)
- Lithium coat must have a uniform layer of 10m with 20% fluctuation in thickness
- One coating process under 10 minutes
- The metallic lithium content of the powder needs to be at least 98%
- Working with the lithium powder must be done in a dry environment
  - AME dry room is 0.5% humidity
  - Lithium reacts explosively to H<sub>2</sub>O

A prototype machine for coating copper anodes with stabilized lithium metal powder (SLMP) will be made by May 2015. General Capacitors LLC along with AME/FSU will be providing the Senior Design group 16 with a budget of \$2000. There are a couple of possible prototypes in mind, every tentative prototype, however, will must meet these constraints. Thorough research on powder metallurgy will be done to be able to understand and reproduce experimentation on the SLMP.

#### 3.1 Design Specifications

##### Product Specifications

- Semi-automatic coating of SLMP on flat electrode
- Loading of SLMPs in range 0.5-3.0 (mg/cm<sup>2</sup>)
- Coating uniformity inside  $\pm 20\%$
- Coating area is should have variable width (5-12 cm) and length (5-250 cm)
- Coating period for each electrode should be less than 10 minutes
- The coating process should be contained to a dry room

### 3.1.1 Overall System

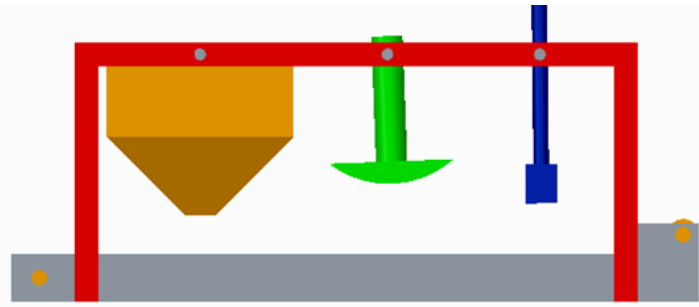

Figure 3-1 Front View

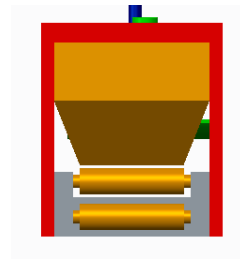

Figure 3-2 Front View

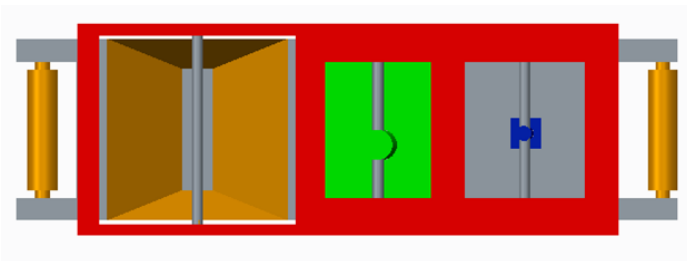

Figure 3-3 Top View

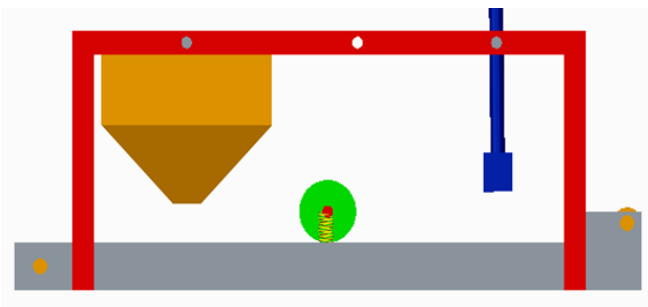

Figure 3-4 Side View

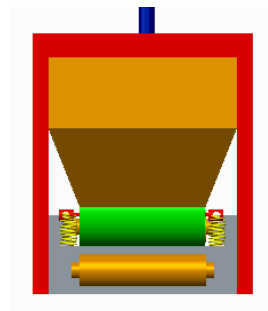

Figure 3-5 Front View



Figure 3-6 Top View

A copper electrode sheet will be continuously pulled by the conveyor belt. The prototype being created to coat a copper electrode sheet consists of three major parts. The first major part is a funnel dropping the SLMP onto the copper electrode sheet. The SLMP is dropped by shaking the funnel with an actuator. The funnel's nozzle is a controlled cross-section in order to evenly coat the electrode sheet. The funnel's cross-sectional shape is to be determined after researching and experimentation. The next step after the funnel is a roller that will lightly press the SLMP onto the electrode sheet to better bond it to the electrode surface. Lastly there will be a punch to cut out the desired shape out of the electrode sheet for to be used electrode. Excess copper and lithium powder will be collected by the base, which acts both as a container and a support for the whole mechanical system.

### 3.1.2 Base

The picture below displays the base of the coating machine. This base is flat with a couple added features to smooth out the coating process. The most noticeable feature being the holes on the side of the plate. These holes will allow for excess SLMP balls to roll off and not affect the pressing of the SLMP onto the anode. Thus allowing for the coating to be uniform throughout the layer of applied SLMP. The next feature you will notice is the two rod holders at each end. These will both hold a role of the anode material, most likely copper. This will also supply the force to move the material throughout the process by using a motor on the back cylinder roller, the elevated roller in figure 8.3 below.

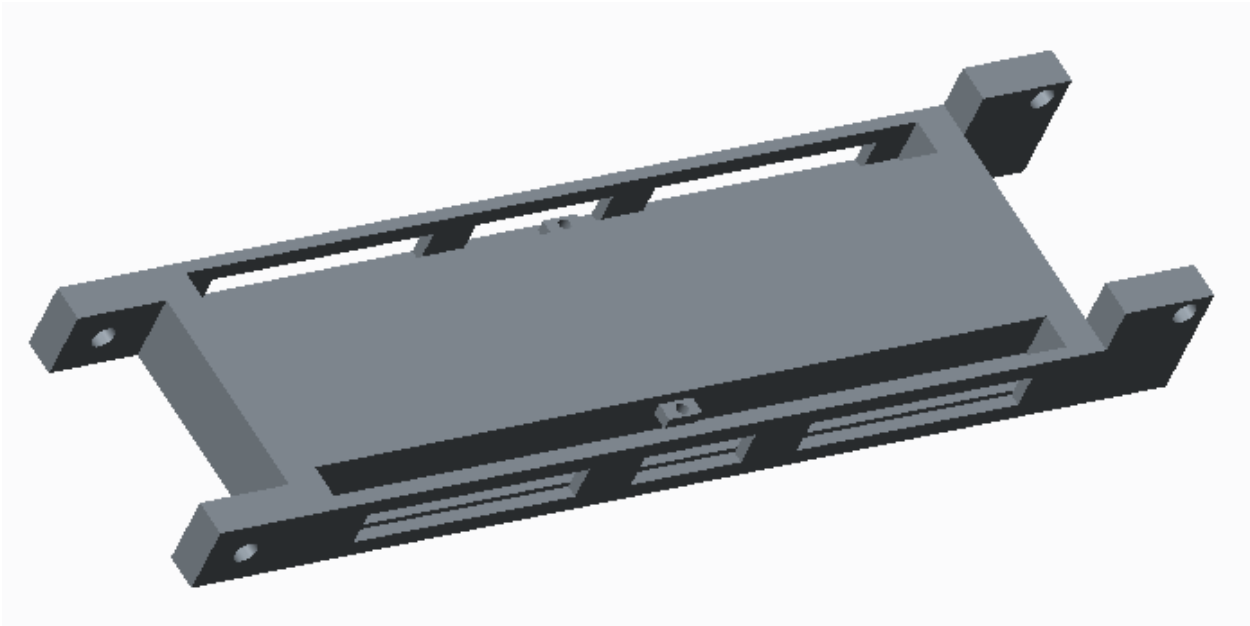

Figure 3-7. Base of the coating machine

### 3.1.3 Funnel

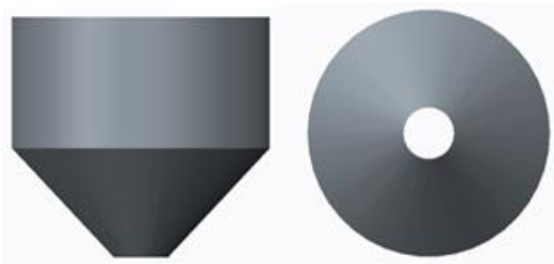

Figure 3-8. Circular with small outlet



Figure 3-9. Square with small outlet



Figure 3-10. Circular with large outlet



Figure 3-11. Square with large outlet

The figures above show a variety of funnel designs that vary in shapes and sizes. These designs are necessary because of the importance to find a design that will allow the lithium powder to flow continually on to the anode material. This leads us to the differences in shapes in

the funnels; two of which are circular (figure 3.8 & 3.10) and the remaining square (figure 3.9 & 3.11 ). The opening of the funnels also differ in size. This will allow more to flow out leading to a larger amount of lithium powder on the anode material before the pressing process begins. The benefits and drawbacks of each won't be determined until testing begins. The large opening may allow too much flow might the large might not be enough. So with testing we can zone in on the best design of the funnel.

### 3.1.4 Mesh

A more important aspect of flow rate will be the gaps between the mesh to cover the funnel opening (figures 3.12). This mesh can also come in a variety of shapes and sizes, from diamonds, circles, squares, or hexagons. Another important decision to make about the mesh is the material choice. It has the possibility of being a fabric, metal, or plastic. In the end decision though the size of the mesh holes will be the deciding factor of how well our funnel will flow with lithium powder. Each of these decisions will be made with immense testing of a prototype. Before a final decision is made about the shape, material, and size of the mesh material



Figure 3-12. Mesh shapes, size, and material difference, image from <http://www.wirecrafters.com/products/wire-partitions-and-cages/woven-and-welded-wire-mesh>

### 3.1.5 Roller vs Half-roller



Figure 3-13. Half-roller

VS

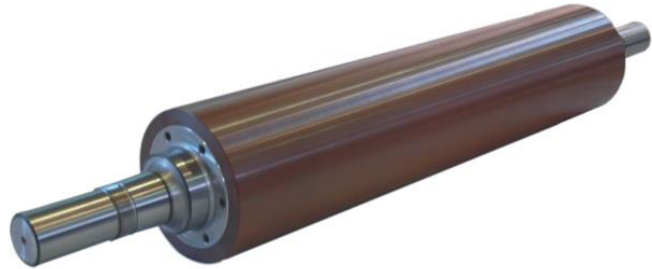

Figure 3-14. Roller, image from <http://www.leelun.com.tw/productENG.html>

The classic roller design is useful for the fast and constant pressing of sheets. Speed is the primary attribute of the roller. With the use of bearings the roller can cover a large amount of area in a given time. A predicted problem that could come from a classic roller method is that the roller would accumulate the stabilized lithium powder on its surface. The roller design, due to bearing friction and roller surface to lithium powder friction, would heat the roller and cause unwanted effects to the SLMP coated electrode. The half-roller design will avoid the heat generation problem by having a controlled pivoting piston motion. The classic roller design also has the possibility of slip. The half-roller's motion will significantly reduce the possibility of slip between the SLMP and the surface of the half-roller. The more pressure the roller has on the electrode sheet, the more likely the SLMP will stick to the roller surface. Being able to control the force the roller has onto the SLMP to electrode is key.

### 3.1.6 Rectangular punch

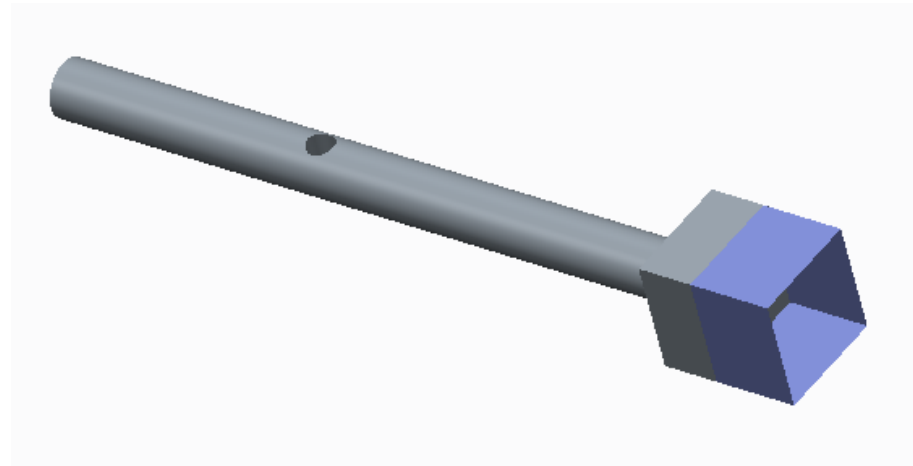

Figure 3-15. Punch to make Specific sized anodes.

After the electrode sheet has been coated on both sides, a punch will be able to cut out the shape of the electrode needed. The punch's head will be interchangeable with whatever needed shape.

## 3.2 Performance Specification

Since our machine is designed to vibrate to drop the SLMP on the electrode the first layer of coating may not always be as uniform as required. However we will move the electrode back and forward 5 times applying a light layer of the SLMP coating each time. By sending the electrode through the machine 10 times we are expecting a greater uniformity since any areas of uneven coating will average out. Another way that we will ensure a uniformity of under 20% is by passing the electrode through a roller and press. This will accomplish two things; It provide a uniform pressure throughout to make the SMLP even more uniform and it will break and press the SMLP onto the electrode.

To test the uniformity of the coating we will be implementing a high speed laser sensor that has a precision measurements of up to 700Hz, with accuracy of up to +/- 0.05% [1]. A laser that would be a good fit with our project is the MICROTRAK PRO -2D. The MICROTRACK PRO 2-D uses triangulation to determine the two dimensional height of a surface [1]. This laser

is cost effective, high speed, and will provide data acquisition feedback allowing the machine to monitor and control the uniformity of the coated SMLP on the electrode.

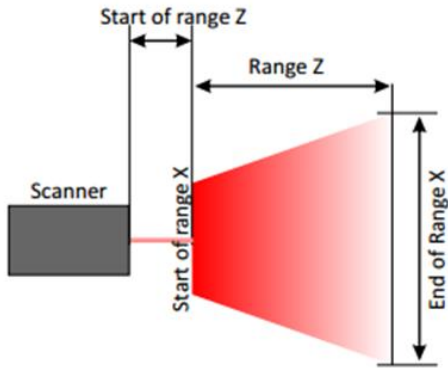

Figure 3-16.Laser Scanner

Performance Specifications

Laser Scanner at 100 Hz (Laser Class 2M)

Description	6/4	10/13	20/10	40/20	60/30	80/40	120/60	220/120	400/200
Measuring Range Z (mm)	6	10	20	40	60	80	120	220	400
Begin Z (mm)	38	65	55	50	53	63	84	115	330
Begin X (mm)	4	13	10	20	30	40	60	120	200
End of Range X (mm)	4.5	15	13	26	40	55	80	160	280
Resolution Z (mm)	0.003	0.01	0.02	0.02	0.035	0.045	0.06	0.11	0.2
Resolution X (mm)	0.008	0.025	0.02	0.04	0.07	0.09	0.14	0.27	0.48
Scan Rate	100 Hz			100 Hz			100 Hz		

\* Values in mm (please see following graphic for details.)

\*\* % of the measuring range

Laser Scanner at 380Hz/ 700 Hz (Laser Class 3R)

Description	80/40	220/120
Measuring Range Z	80	220
Range Begin Z	75	140
Range Begin X	40	120
End of Range X	55	180
Resolution Z *	0.045	0.11
Resolution X *	0.04 (0.08)	0.14 (0.28)



Figure 3-17.MICROTRAK PRO 2-D Performance Specifications [1]



Table 3-1.Laser Scanner Specifications

Supply Current Requirements	120 mA at 24VDC
Power Supply	8-30 VDC; 15W
Laser Lifetime	50,000 Hours
Linearity Range	0.2%
Temperature Range	Minimum (0°C), Maximum (40°C)

This machine will have a user interface allowing one to control the coating area size by choosing from a selection of set sizes or by entering a set area. There will be up/down, left/right, and an enter button for the user to press and choose their desired sizes. Maximum sizes are 12 cm wide and 250 cm long and minimum sizes are 5 cm wide to 5 cm long. Once the user selects their desired size the machine will then shrink or lengthen the width and will start coating the electrode until the set length is reached and will then reverse the motion bringing it back to its starting point and will repeat 5 times.

One of the requirements is that the machine can coat the electrode in less than 10 minutes. Since the design we will be implementing uses a dry method and has no drying time the machine will be able to coat the powder slower and more uniformly. This dry coating method will conservatively take 5 minutes to coat and press the electrode with the SMLP.

Since this machine is a relatively small prototype it will not draw very much power and will be able to be plugged into a 120V power source. We will need to power our control devices, rollers, motors, sensors, inverter, fuses, etc. Pressure sensors will be used as well to control the amount of pressure applied once the coating phase is completed. The rollers must apply subsequent pressure so that the powder material adheres to the electrode.

## 4 Methodology

For the Dry Method coating of the Stabilized Lithium Metal Powder on the electrode we will use an assembly line technique. Basically the electrode will be on a moving surface that will be sent under the dropping SLMP and will be coated until a uniform surface is made. We will have a reservoir of SLMP in a triangular shaped trough that has a series of metal meshes to slow the flow of the SLMP leaving the machine. To keep the SLMP from constantly dropping we will position the meshes to keep the powder from dropping under normal circumstances but when vibrating will allow the SLMP to fall through. Since this vibration will cause the SLMP not to constantly fall in a uniform pattern the machine will move the electrode back and forward 5 times allowing for each spot of the electrode to get coated 10 times and increasing the likelihood of an uniform coat due to the law of averages.

Additionally, once the electrode is coated 10 times and has a uniformly coated layer of SMLP we will then move the electrode out of the way and press the SLMP layer to the electrode with a large press and roller to further increase the uniformity of the coating layer and to break the SMLP to make it stick on the electrode.

Our coating machine will also have a user interface allowing them to choose their desired coating area. This will be done by installing a small LED screen and up/down, left/right, and a select button to allow the user to have control of the machine by either changing the width of the SLMP dropping or changing the horizontal distance the electrode travels to allow for the entire electrode to be coated while cycling back and forward.

### 4.1 Schedule

To properly develop a prototype machine that will uniformly coat an electrode with stabilized lithium metal powder a strict schedule must be adhered to. Below in Figure 4-1 is a breakdown of all of the tasks and milestones required to fulfill our goal. Many of the tasks will be dependent on precedent work, while others will grow upon one another from this point forward. Typically major tasks will be given a 7-day period for completion. For Milestones the time period can range from a 14-day to 30-day period. The time limit assigned is based on the amount of research, analysis, and labor that we as a team have deemed necessary for each task.

# Stabilized Lithium Metal Powder Coating Machine

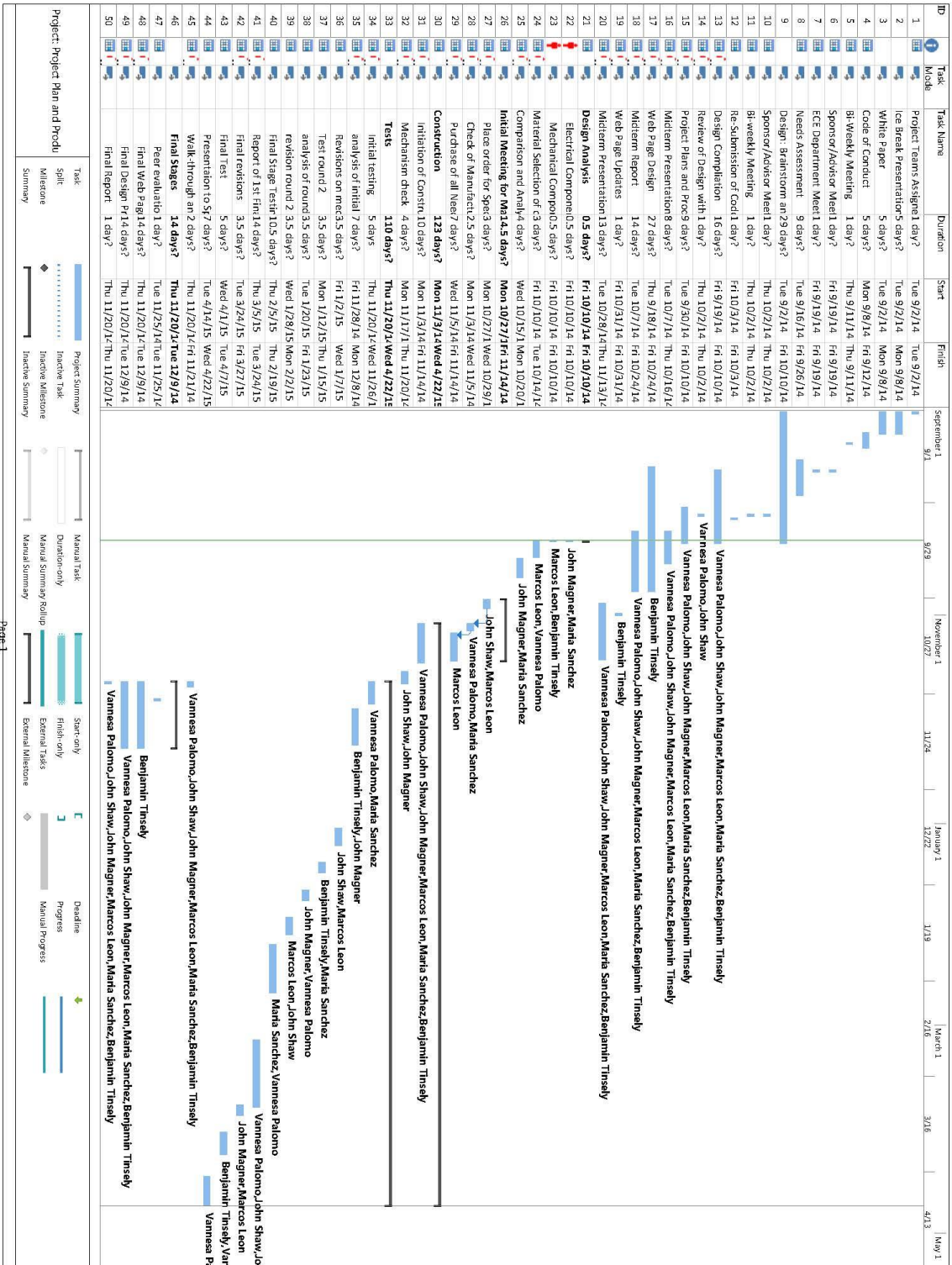
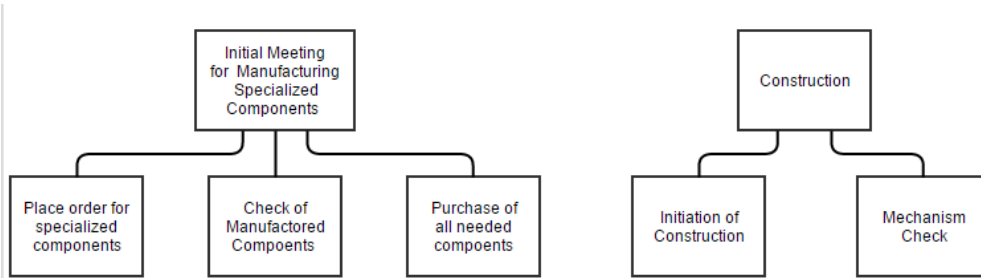
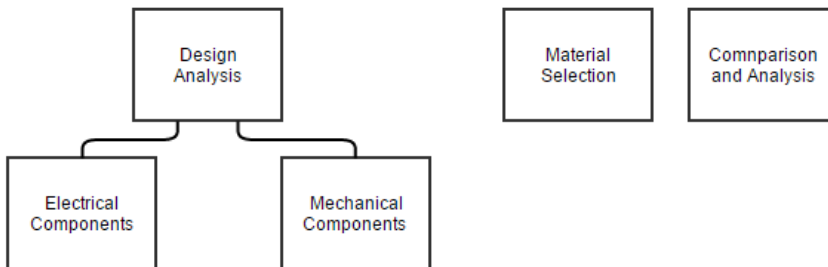
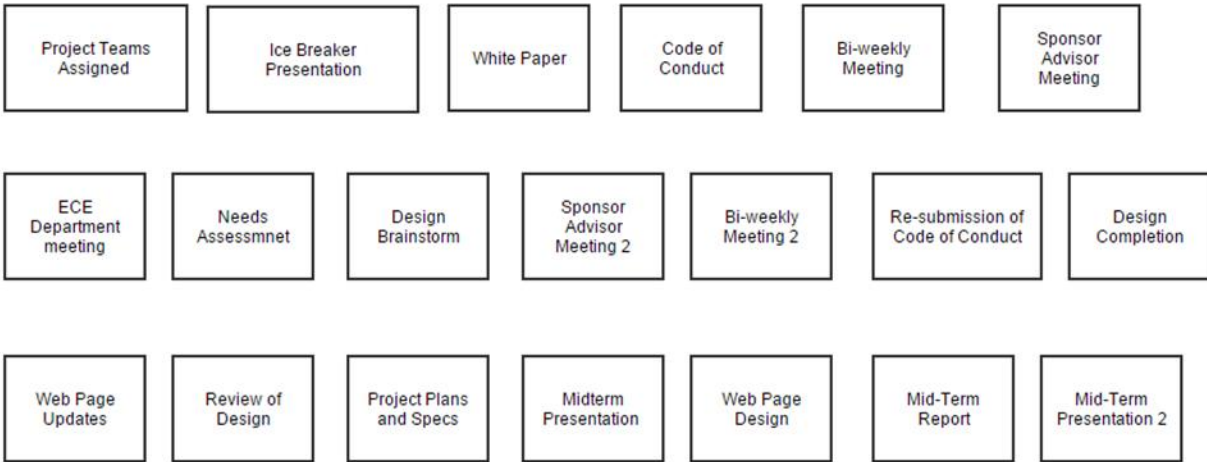

Figure 4-1. The Gantt Chart of the SMLP project schedule.

## Stabilized Lithium Metal Powder Coating Machine

The work breakdown structure, WBS, found below in Figure 4-2, is an organizational chart that breakdown the tasks from the Gantt Chart into a hierarchy structure. This structure clearly shows the dependency of specific tasks on one another, as well as some that are independent of one another. It will be used to help our team understand what tasks will have to be closely related to others and what will be effected by prior work.



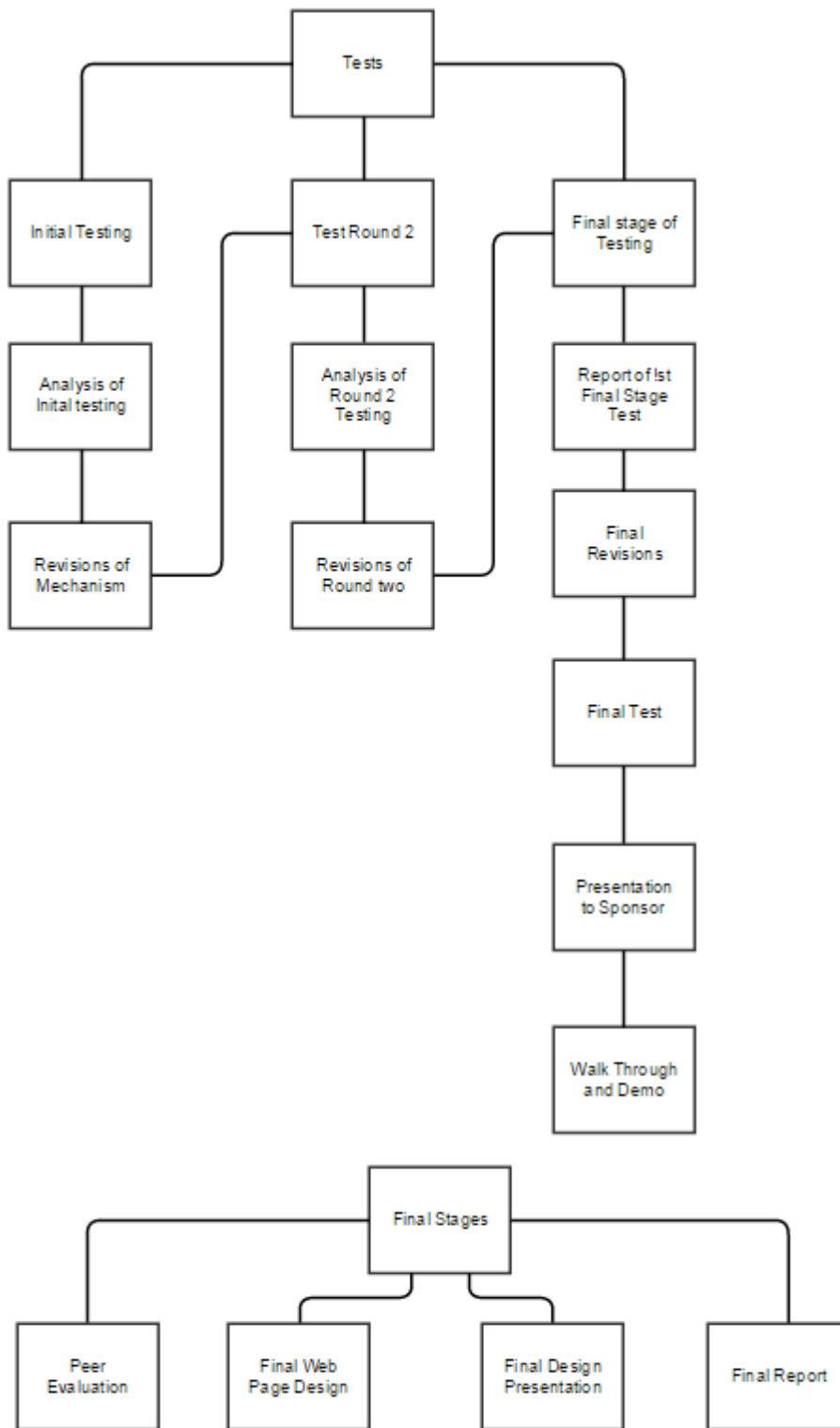

Figure 4-2. The work breakdown structure depicts all major tasks and milestones and the hierarchy between them.

## 4.2 Resource Allocation

Each and every member of the team will be responsible for certain labor over sections of the project during a predetermined time period. The tasks have been fairly divided up throughout the year as to not overwhelm each team member. Table 1.1, Resource Allocation, is the clear breakdown of all tasks and milestones to specific team members as shown in Figure 9-1, the Gant Chart.

Table 4-1. The resource allocation table breaks down the tasks in the schedule to specific team members

Team Member	Task/ Milestone Assigned
Marcos Leon	<ul style="list-style-type: none"> <li>• Presentation to Sponsor</li> <li>• Place order for Specialized components</li> <li>• Mechanical Components</li> <li>• Final Design Presentations</li> <li>• Report of 1st Final Stage test</li> <li>• Final Report</li> <li>• Midterm Presentation</li> <li>• Initiation of Construction</li> <li>• Midterm Report</li> <li>• Purchase of all Needed Components</li> <li>• Revisions on mechanism</li> <li>• Walk-through and Demo</li> <li>• Project Plans and Product Specs</li> <li>• Revision round 2</li> <li>• Design Compilation</li> <li>• Final revisions</li> <li>• Midterm Presentation 2</li> <li>• Material Selection of components</li> </ul>

## Stabilized Lithium Metal Powder Coating Machine

<p>Vannesa Palomo</p>	<ul style="list-style-type: none"> <li>• Presentation to Sponsor</li> <li>• Walk-through and Demo</li> <li>• Project Plans and Product Specs</li> <li>• Final Test</li> <li>• Midterm Presentation 2</li> <li>• Midterm Report</li> <li>• Design Compilation</li> <li>• Material Selection of components</li> <li>• Report of 1st Final Stage test</li> <li>• Check of Manufactured Components</li> <li>• Final Report</li> <li>• Initial testing</li> <li>• Final Design Presentations</li> <li>• Midterm Presentation</li> <li>• Final Stage Testing with SLMP</li> <li>• Review of Design with Advisor and sponsor</li> <li>• Analysis of round 2</li> <li>• Initiation of Construction</li> </ul>
<p>John Shaw</p>	<ul style="list-style-type: none"> <li>• Final Design Presentations</li> <li>• Midterm Report</li> <li>• Midterm Presentation</li> <li>• Mechanism check</li> <li>• Walk-through and Demo</li> <li>• Report of 1st Final Stage test</li> <li>• Midterm Presentation 2</li> <li>• Final Report</li> <li>• Revision round 2</li> <li>• Project Plans and Product Specs</li> <li>• Design Compilation</li> </ul>

Stabilized Lithium Metal Powder Coating Machine

	<ul style="list-style-type: none"> <li>• Review of Design with Advisor and sponsor</li> <li>• Presentation to Sponsor</li> <li>• Place order for Specialized components</li> <li>• Initiation of Construction</li> <li>• Revisions on mechanism</li> </ul>
John Magner	<ul style="list-style-type: none"> <li>• Midterm Presentation 2</li> <li>• Electrical Components</li> <li>• Final Design Presentations</li> <li>• Initiation of Construction</li> <li>• Report of 1st Final Stage test</li> <li>• Project Plans and Product Specs</li> <li>• Walk-through and Demo</li> <li>• Comparison and Analysis of Material Selection</li> <li>• Design Compilation</li> <li>• Final Report</li> <li>• Midterm Presentation</li> <li>• Analysis of round 2</li> <li>• Presentation to Sponsor</li> <li>• Final revisions</li> <li>• Mechanism check</li> <li>• Midterm Report</li> <li>• Analysis of initial testing</li> </ul>
Benjamin Tinsley	<ul style="list-style-type: none"> <li>• Project Plans and Product Specs</li> <li>• Final Test</li> <li>• Final Web Page Design</li> <li>• Report of 1st Final Stage test</li> <li>• Presentation to Sponsor</li> <li>• Initiation of Construction</li> <li>• Walk-through and Demo</li> </ul>



## Stabilized Lithium Metal Powder Coating Machine

	<ul style="list-style-type: none"> <li>• Test round 2</li> <li>• Final Design Presentations</li> <li>• Mechanical Components</li> <li>• Midterm Presentation</li> <li>• Web Page Updates</li> <li>• Design Compilation</li> <li>• Analysis of initial testing</li> <li>• Midterm Presentation 2</li> <li>• Final Report</li> <li>• Midterm Report</li> <li>• Web Page Design</li> </ul>
<p>Maria Sanchez</p>	<ul style="list-style-type: none"> <li>• Test round 2</li> <li>• Initial testing</li> <li>• Initiation of Construction</li> <li>• Report of 1st Final Stage test</li> <li>• Electrical Components</li> <li>• Design Compilation</li> <li>• Midterm Presentation</li> <li>• Final Stage Testing with SLMP</li> <li>• Midterm Presentation 2</li> <li>• Final Design Presentations</li> <li>• Comparison and Analysis of Material Selection</li> <li>• Check of Manufactured Components</li> <li>• Final Report</li> <li>• Midterm Report</li> <li>• Project Plans and Product Specs</li> <li>• Presentation to Sponsor</li> <li>• Walk-through and Demo</li> </ul>

## 5 Conclusion

In conclusion the prototypal machine's exact final design cannot be chosen at this juncture. The coating processes being explored are dry methods in an assembly array. The flat electrode will be loaded onto the assembly array, first being powdered with an even coat of SLMP by the vibrating funnel. At the funnel exit, there will be a layered mesh experimentally aligned to provide the desired drop rate of SLMP in a uniform fashion. After the funnel the powdered electrode will be rolled with negligible pressure to ensure thickness uniformity and to ensure that the light lithium will not stick to the roller. Options we are exploring for the roller include full and half rollers. The half roller seems more applicable due to its benefit of less heat generation while in contact with the highly reactive lithium. Additionally the half roller is less likely to incur slip, which would lead to less differences in uniformity. After both sides of the electrode are evenly coated, the electrode will be punched to the desired shape. It is clear that much experimentation is required to determine the optimal coating design. Essential elements to research include funnel shape, different mesh combinations, and rolling technique.

## 6 References

- [1] Bruce, Peter G. "Rechargeable Lithium Batteries [and Discussion]." *Philosophical Transactions: Mathematical Physical and Engineering Sciences*. Vol. 354, No. 1712, Materials for Electrochemical Power Systems (1996): 1577-594. [Http://www.fmclithium.com](http://www.fmclithium.com). Web. 26 Sept. 2014.
- [2] "Introducing Stabilized Lithium Metal Powder – A New Way To Think of Lithium." (n.d.): n. pag. [Http://www.fmclithium.com](http://www.fmclithium.com). Web. 26 Sept. 2014. <<http://www.fmclithium.com/Portals/FMCLithiumEnergy/Content/Docs/SLMP%20Marketing%20Sheet%20Final.pdf>>.
- [3] "Knife System - Roller Knife and Air Knife." *Coatema*. N.p., n.d. Web. 26 Sept. 2014.
- [4] Krebs, Robert E.. *The history and use of our earth's chemical elements: a reference guide*. 2nd ed. Westport, Conn.: Greenwood Press, 2006. Print.
- [5] "LEE LUN ROLLER." *LEE LUN*. LEE LUN, n.d. Web. 09 Oct. 2014. <<http://www.leelun.com.tw/productENG.html>>.
- [6] MTI Instruments. "MICROTRAK PRO 2-D." *2D Laser Sensor* (n.d.): n. pag. *MTI Instruments*. Apr. 2014. Web. Oct. 2014.
- [7] "Patent US20090035663 - Stabilized Lithium Metal Powder for Li-ion Application, Composition and Process." *Google Books*. N.p., n.d. Web. 26 Sept. 2014.
- [8] Wang, Ui, and Yanbao Fu. "Application of Stabilized Lithium Metal Powder (SLMP®) in Graphite Anode." [Sciencedirect.com](http://www.sciencedirect.com). *Journal of Power Sources*, 28 Feb. 2014. Web. 26 Sept. 2014.

[9]"Woven & Welded Wire Mesh." *WireCrafters*. WireCrafters LLC, n.d. Web. 10 Oct. 2014.  
<<http://www.wirecrafters.com/products/wire-partitions-and-cages/woven-and-welded-wire-mesh>>.