



FAMU- FSU College of Engineering
Department of Mechanical Engineering
Dr. Gupta, Dr. Shih, Dr. Frank
Senior Design II: EML4552C

WIRELESS INFRARED MONITORING SYSTEM **DESIGN FOR MANUFACTURING, RELIABILITY &** **ECONOMICS REPORT**

4/3/2015

Authors

Michelle Hopkins, Project Manager, Mechanical Engineering, meh09d
Nixon Lormand, Mechanical Lead, Mechanical Engineering, njl08c
Kenny Becerra, Electrical Lead, Electrical & Computer Engineering, kb10j
Joseph Besler, Procurement Chair, Mechanical Engineering, jkb11d
Alexander Hull, Programming Chair, Computer Engineering, ah12r
Jonathan Jennings, Prototyping Chair, Mechanical Engineering, jwj08c

Advisors

Dr. Patrick Hollis, Mechanical Engineering Associate Professor
Dr. Rajendra Arora, Electrical & Computer Engineering Professor

Liaison

James Sharp, Principal Engineer, Siemens Energy Inc.

SIEMENS

ABSTRACT

This project has been initiated and delegated to our Senior Design Team of Florida State University's Mechanical Engineering Program by Siemens Energy in order to investigate a more effective, simplified preventative maintenance technique incorporating the use of Infrared Technology. Siemens has expressed their interest in a conceptual design of a Wireless Infrared Monitoring System that will monitor fossil fuel power plant equipment for problematic operation. They wish for this designed system to ultimately reduce costs through replacement of existing thermocouples used for temperature monitoring as preventative maintenance. A conceptualized system has been designed and consists of three major subsystems: the Monitoring System, the Power System, and the Mounting System. The Monitoring System is comprised of the infrared camera, pan tilt module, microcomputer and wireless adapter. The infrared camera will survey selected targets thoroughly, precisely, and without interfering with the equipment. The pan tilt module will control the camera's position allowing it to target a wide range of equipment thus reducing the need for numerous systems. The microcomputer will control the camera and pan-tilt module as well as filter and package the infrared data to be sent wirelessly via an adapter to the control room. The Power System will consist of an accurately sized solar panel, charge controller, battery, and inverter to properly power the system throughout the systems lifetime making it self-sustaining. Finally, the Mounting Structure will consist of a pole, weather enclosure, supports, and fasteners necessary to house, secure, and protect all the monitoring and power components from the elements. Each of these three major subsystems and subsequent components must be integrated correctly for each of their respective functions to contribute to the final success of the system. This report will break down the manufacturing economics, and reliability of our system design. [1]

ACKNOWLEDGEMENT

We would like to acknowledge our sponsor, Siemens Energy Inc., for their donation and support of this project and the Senior Design program at the College of Engineering. James Sharp, specifically, has always been available for technical advising and deliverable review and has served as a great liaison. We would also like to thank Seminole Electric for taking the time to give us a tour of their power plant, R.J. Midulla, and educating us on the equipment that our system will be monitoring. We would like to thank our faculty advisors; Dr. Patrick Hollis and Dr. Rajendra Arora and the instructors of Senior Design; Dr. Nikhil Gupta and Dr. Chiang Shih, all of who have provided valuable feedback and advising. Lastly we would like to thank Dr. William Oates for loaning his infrared camera for our prototype development.

TABLE OF CONTENTS

Abstract.....	ii
Acknowledgement.....	iii
I. Introduction.....	1
II. Design for Manufacturing.....	3
III. Design for Reliability.....	8
IV. Design for Economics.....	13
V. Conclusion.....	15
References.....	16
Appendix 1: Component Specification DataSheets.....	17
A. Infrared Camera.....	17
B. Pan-Tilt Module.....	20
C. Microcomputer.....	21
D. Wireless Communication.....	22
E. MPPT Charge Controller.....	23
F. Inverter.....	24
G. POE Splitter.....	25
H. Solar Panel.....	26
I. Battery.....	27
Appendix 2: Power System Homer Analysis.....	28
Appendix 3: Final System Analysis.....	32
Appendix 4: Proposed Locations.....	34
Appendix 5: Bill of Materials.....	35
Appendix 6: Exploded Views and Drawings.....	37
Biography.....	45

TABLE OF FIGURES

Figure 1. Exploded View of System.	3
Figure 2. Solar Mounting A-Frame.	4
Figure 3. Pan Tilt Assembly Schematic.	4
Figure 4. Microcomputer Setup.	6
Figure 5. PS-24 Mains Power Adaptor.	6
Figure 6. FLIR Camera ports.	7
Figure 7. Power System Assembly.	7
Figure 8. Charge Controller LCD Legend.	8
Figure 9. Wind Analysis on Solar Panel.	10
Figure 10. Cap screw under nominal 25lbf load.	11
Figure 11. Half U-bolt simulated under nominal tension and shear.	12
Figure 12. Steel pole compressed with subsystem loads.	12
Figure 13. Design vs. Prototype Budgets.	13
Figure 14. System Design and Prototype Cost Breakdown.	14
Figure 15. Design Sub-System Costs.	14
Figure 16. Market Competiveness.	15
Figure 17. Daily Load Profile Input.	28
Figure 18. Solar Resource Input.	28
Figure 19. PV Panel Settings.	29
Figure 20. Battery Selection, Specification, and Settings.	29
Figure 21. Optimization Results of 150 W Panel with 2 55 Ah Batteries.	30
Figure 22. Photovoltaic Output Analysis over 1 year.	30
Figure 23. Battery Analysis: State of Charge Simulation over a year.	31
Figure 24. System Charge and Discharge Analysis over 7 days.	31

TABLE OF TABLES

Table 1. System Constraints. 1
Table 2. IBC2006 Code. 2
Table 3. Failure Mode Effect and Analysis. 9
Table 3. Drag Force and Components. 10
Table 4. Ground Moment Calculation. 11

I. INTRODUCTION

Currently, power plants use a large network of thermocouples and local vibration monitoring devices to capture temperature and vibrational data of operating equipment. The thermocouples only measure a small local area. Therefore, numerous thermocouples must be individually tapped to each location that needs to be measured. Thus, there must be thermo-wells drilled into any protective casing or piece of equipment that necessitates temperature readings. The thermocouples are then wired to a local junction box, and then through underground conduit all the way back to the control room. The data is used to determine pre-explosive or pre-failure conditions indicative of necessary maintenance in order to prevent major power plant outages. This is called preventative maintenance and is critical in power plants lifetimes after about 10 years. All of these individual systems are invasive, costly, and complicated to implement and beckons for consolidation, simplification, and improvement.

Siemens, as an energy service provider, is interested in investigating a more simplified and effective preventative maintenance technique. Specifically, they are interested in exploring the use of infrared technology. Infrared cameras can be utilized to monitor the temperature of operating equipment, enabling it to diagnose potential problems long before other traditional systems. The cameras are also noninvasive and do not require equipment interference.

Siemens Energy has initiated this project to explore incorporating this technology in a conceptual design of a Wireless Monitoring System to improve their preventative maintenance service. This project has been delegated to our team to find a plausible system solution to the following goal statement and four objectives. [2]

“Design a proposed complete system that can monitor a wide range of equipment for problematic operation.”

1. Decrease equipment interference on operating systems.
2. Create cost savings through the elimination of need for numerous existing systems.
3. Decrease manual work needed for preventative maintenance.
4. Design a stand-alone system that does not consume any plant power.

The following table, Table 1, captures the design constraints of this project set forth by Siemens. [2]

Table 1. System Constraints.

Subject	Descriptor	Constraint
Location	Exclusively	Fossil Fuel Power Plants
Lifetime	At least	30 years
Monitoring	Type	Thermal Imaging, up to 300°C
Power	Source	Solar Harvesting
Battery Storage	At least	3 days
Communication	Wireless	300m
Communication	Protocol	HART
Compliance	Code	NERC, IBC2006
Weatherproofing	Rating	IP55
Movement	Range	360° in horizontal, 90° in vertical
System Cost	Maximum	\$20,000

Prototyping Budget	Maximum	\$3,000
--------------------	---------	---------

Table 2. IBC2006 Code.

Seismic Loading	Occupancy Category III
	Site Class D
	$S_s = 0.41g, S_1 = 0.19g$
Wind Loading	$V_{3s} = 100$ mph
	Exposure C
Rainfall	5"/hr for 1 hr in a day
Ambient	0-110°F

The testing site that will ultimately implement this product is a 2x1 combined cycle power plant called Richard J. Midulla. It is owned by Seminole Electric and provides about 810 MW to Hardee County, Florida. [3] The plant is almost 15 years old and at the height of its maintenance period. A layout of the site can be found in Appendix 4.

II. DESIGN FOR MANUFACTURING

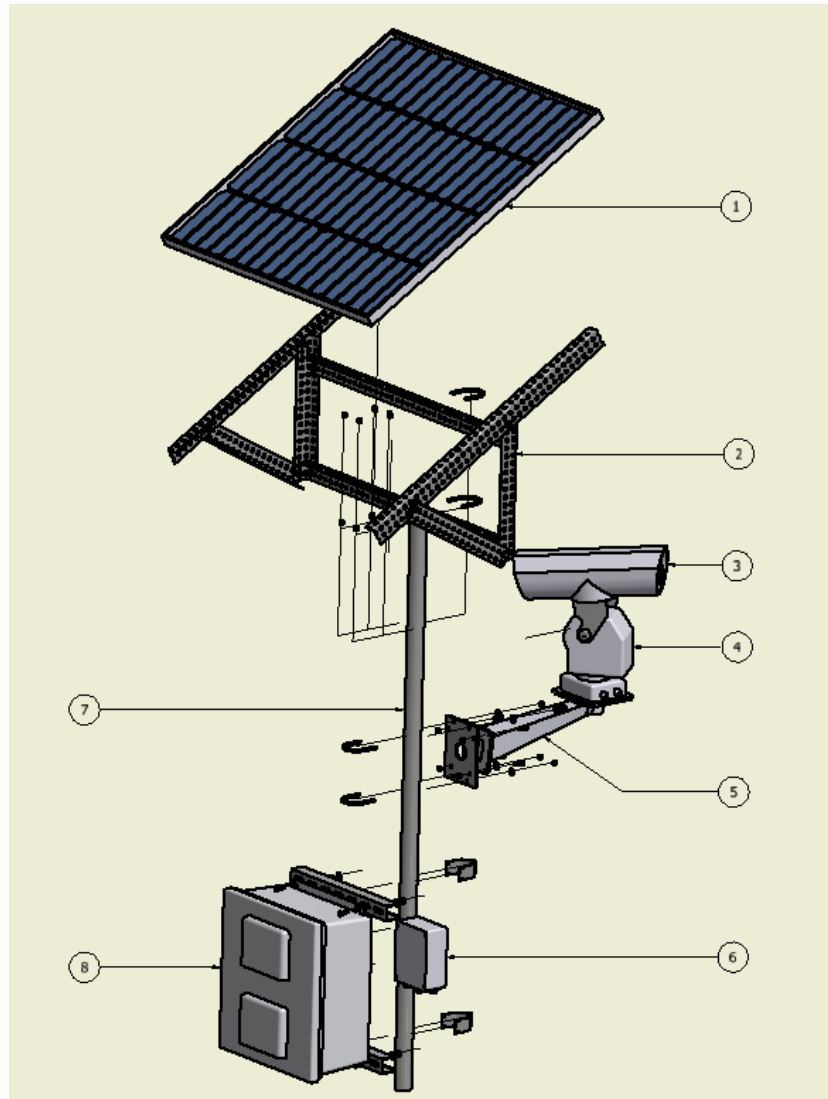

Figure 1. Exploded View of System.

Please refer to Appendix 6 for exploded views and drawings of the full system and subassemblies. An exploded view of our system model can be seen in above in Figure 1. Following is a step-by-step procedure for assembling the system. Total assembly time is approximately 4 hours assuming all individual components were tested and functioning beforehand.

1. Cut track stock and strut channel stock into two 17.5", 38.0", and 38.8" pieces. See 90° Track Dimensioned Drawing in Appendix 6.
2. Using simple trigonometry, the length of the final set of 90° track pieces can be determined and cut so that the angle equals the local latitude of implementation. For example, for a solar panel tilted at 30°, the final set of 90° track pieces should be cut to

17" and secured at an angle of 60 degrees from the 17.25" vertical track pieces as seen in Figure 2.

3. Cut the strut channel stock into two 18" pieces. See Strut Dimensioned Drawing in Appendix 6.
4. Assemble two A-frames of the solar mounting structure, Figure 2, using cap screws, nuts, and washers to ensure stability.
5. Connect two assembled A frames with two 38.8" struts according to Solar Mounting Sub-Assembly in Appendix 6.

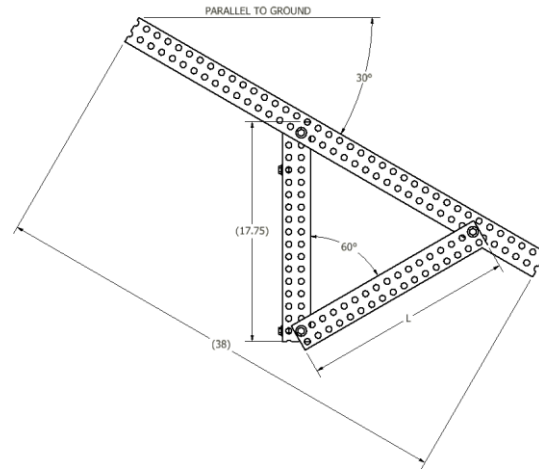

Figure 2. Solar Mounting A-Frame.

6. Mount the solar panel to the 90 degree track utilizing the 4 mounting holes on the back of the solar panel using the given mounting screws and nuts.
7. Place pan tilt motor on the wall bracket and secure. See Figure 3.
8. Mount infrared camera to pan tilt splint using given bolts and washers.

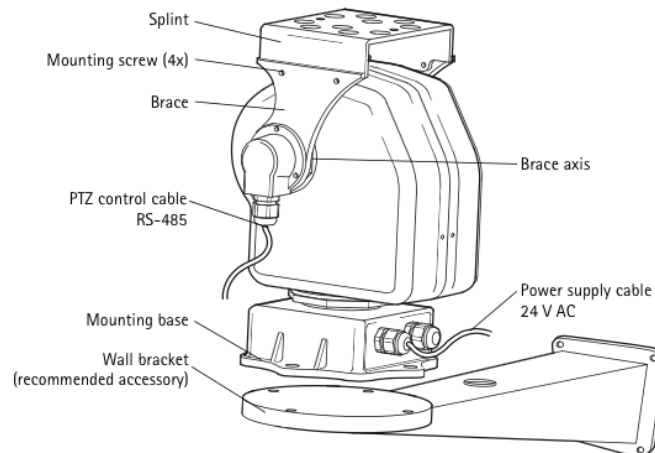

Figure 3. Pan Tilt Assembly Schematic.

9. Take the manufactured pan tilt mounting bracket and secure it to the pan tilt arm via the given screws, nuts, and washers. See the pan tilt sub assembly drawings in Appendix 6 for reference and Figure 3.
10. Run the camera and pan tilt wires through the inside of the pan-tilt mounting arm and out of the mounting bracket but leave enough slack to allow the pan tilt module to full move.
11. Take the 18" pieces of strut channel and secure to the back of the weather enclosure using the given cap screws, nuts, and washers given. Take care in ensuring that the flat side of the track is flush with the back of the enclosure.
12. Using, the enclosure sub assembly drawing in Appendix 6, orient the electronic components to fit within the enclosure. Run all necessary component wires through the punch outs and ½" conduit conductor located at the bottom of the enclosure.

NOTE: Locate weather enclosure and solar panel appropriately before securing to the pole with U-bolts. In general, the enclosure should be mounted as close as possible to the pan tilt/camera and the solar panel should be as high as possible.

13. Slide the strut channel clamps onto the strut channel located on the back of the enclosure.
14. Use the given clamp screw and nut to close the clamps and secure the enclosure mount to the central pole. This can be seen in the detailed view on sheet two of the enclosure subassembly drawing in Appendix 6.
15. To secure the solar and pan tilt mounts to the mounting pole, use the given U-bolts, nuts, and washers.

NOTE: Make sure that all of the mounted components are secured tightly to the back of each mounting subsystem. Please reference the full assembly drawings in Appendix 6 before proceeding with circuit setup.

16. Connect Microcomputer, ATX Power Supply, harddrive, and accessories according to Tiger Reference Manual for assembling the microcomputer components. [4]

NOTE: the keyboard, computer screen, mouse, and CD-ROM drive are not necessary components to run this system, only for initial programming.

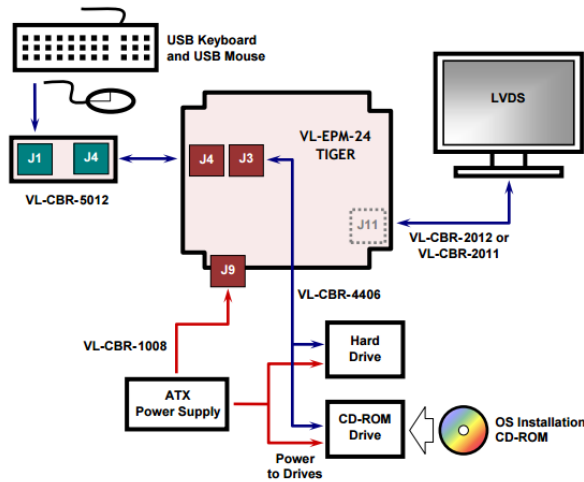

Figure 4. Microcomputer Setup.

17. Plug the ATX Power Supply input power cord into the Samlex Inverter.
18. Connect the spliced Pan Tilt RS-485/serial cable to one of the serial ports on the microcomputer’s breakout board. [5]
19. Connect the pan tilt power cable to the Mains Adaptor, see Figure 5 below and see Axis Communication’s PS-24 Mains Adaptor Installation Guide. [6]

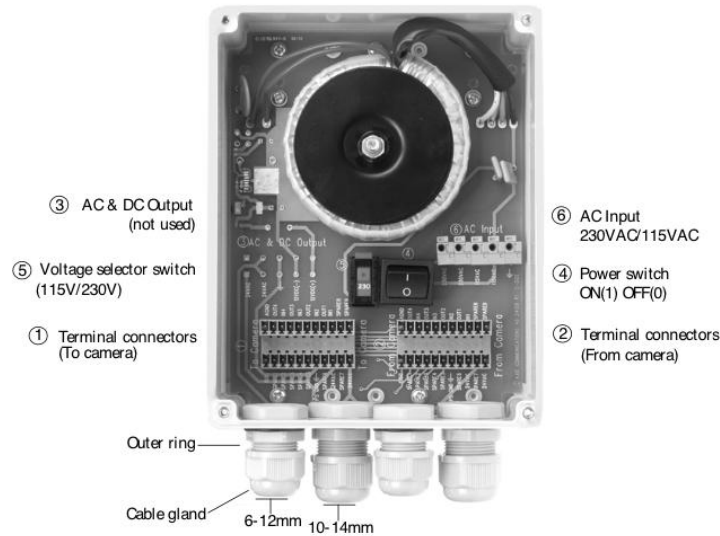

Figure 5. PS-24 Mains Power Adaptor.

20. Plug the Mains Adapter input power cable into the Samlex Inverter.
21. Connect the POE Cable to the GigE (port 5 on Figure 6) on the camera and connect the other end to the POE Splitter Ethernet port. Refer to FLIR User Manual. [7]
22. Connect Ethernet cable from the microcomputer breakout board, to the LAN output of the POE Splitter.

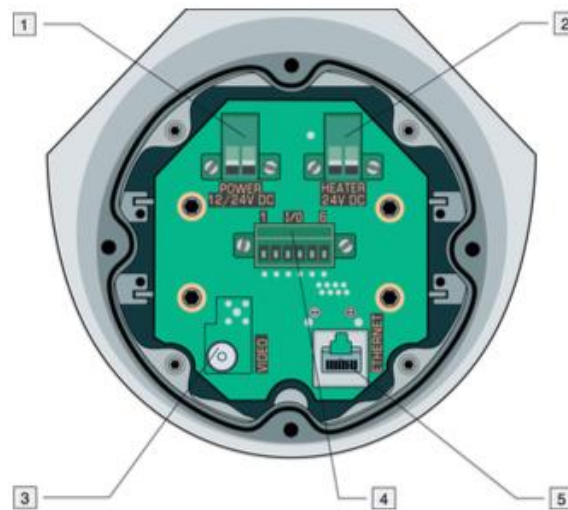

Figure 6. FLIR Camera ports.

NOTE: Refer to xEco-Worthy MPPT Solar Charge Controller Guide and Figure 7 for steps 23 to 28. [8]



Figure 7. Power System Assembly.

23. Connect Battery cables to charge controller.
24. Wire 12VDC POE Splitter and Inverter power cables in parallel to 'Load' terminals on charge controller. Refer to Inverter user Manual for directions. [9]
25. Connect Solar Panel to charge controller.
26. Switch on battery.
27. Enter in the following values on the Charge Controller LCD Display using the +- buttons for the system setup [8]
 - a. System Voltage: 12V
 - b. Over Charge Voltage Setting: 14.6V
 - c. Float Voltage Setting: 13.7V
 - d. Discharge Protection Setting: 10.8V
 - e. Discharge Restart Voltage Setting: 11.3V
 - f. Output Mode: Mode 2 (Always On)

28. Ensure home screen is reading the appropriate values for the current conditions, see Figure 9.

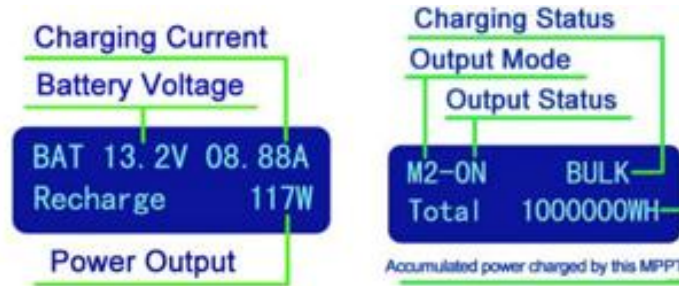

Figure 8. Charge Controller LCD Legend.

III. DESIGN FOR RELIABILITY

Our system is designed to be running continuously on 2-minute power cycles followed by 10 minutes sleep cycles. Once initialized and executed, the system should run autonomously and uninterrupted until maintenance or troubleshooting is necessary. The lifetime of our system should hold up to 30 years however the battery is calculated to last 6.15 years before replacement is needed. In addition, the solar panel has a lifetime of 20 years before the solar cells begin to degrade. Therefore, our system should perform up to 15 years of its lifetime with proper battery maintenance. The second half of its life however, the operator may begin to see some solar power and efficiency losses. If this is detrimental to the systems performance, the solar panel could be replaced. Please see Appendix 2 for Power System Simulation and Analysis.

The largest concern for our system aside from, eventual lifetime degradation are described in A Failure Mode Effect and Analysis (FMEA) table on the following page. Some of the weather constraints showed in Table 1 in the Introduction, are very tumultuous conditions (100 mph wind, 5" rain for 1 hour period, and 0-110°F temperatures). The system is designed to be modular to allow for easy installation and removal. In order to avoid damage, the plant owner should disassemble and store the 3 subassemblies in any case of bad weather. Pest can reduce the longevity and performance of this system. Nesting can cause harm when considering the pan-tilt arm, solar panel, enclosure, or hand hole of the pole. A pest nesting within the enclosure can cover important electronics with nesting debris and chew away at the equipment. Some of the damaged items will require replacement if chewed on or allowed to overheat. The potential problems can be easily abated through pesticides and regular inspection. Improper installation can result in premature product failure. In general, it should be ensured that all installation guidelines are followed and necessary precautions taken. Corrosion is also a concern but can easily be mitigated with proper maintenance and application of ANSI 61 paint to exposed carbon steel components. Finally, system location is integral to performance and safety. The switchyards are very high voltage areas and can present a danger of arcing when something is located poorly. Also, the HRSG and transformers are very high temperature components whose heat can greatly increase the local ambient temperature. Appendix 4 details the recommended system locations that are ultimately up to the operator/owner.

Table 3. Failure Mode Effect and Analysis.

Key Process Step or Input	Potential Failure Mode	Potential Failure Effects	SEV	Potential Causes	OCC	Current Controls	DET	RPN	Actions Recommended	Resp.
Weather Protection	Severe Weather	Potential fastener failure and exposed component damage.	10	High Winds	2	Disassembly Procedure.	10	100	Pay attention to weather forecasts.	Owner/ Operator
Operation	Nesting Pests	Electrical Wiring Failure.	5	Bugs	10	Weekly System Inspection	10	500	Pesticides.	Owner /Operator
Installation	Improper Installation	Short Circuits, Mounting Failure, Lack of performance, etc.	10	Improper installation of components and equipment.	1	Installation and Troubleshooting Manual	8	80	Following manuals and inspecting before troubleshooting.	Erector
Mounting Structure	Corrosion	Failure/degradation of pole	4	Oxidation	10	Painting Specification	10	400	Paint pole with ANSI 61 paint frequently to prevent exposure.	Owner/ Operator
Location	High Voltage or High Heat Areas	Electronic failure.	10	Poor location of system.	1	Recommended Locations.	5	50	Investigate potential locations before installation.	Owner/ Operator

In order to decrease concern over mounting system stress, wind and force loading was performed in Comsol. The resulting wind loading analyses are shown in Table 3. These values were determined utilizing the FEA software. The solar, pan-tilt, and enclosure subassemblies were oriented such that their largest surface was acted upon by the wind. The projected areas (EPA) of each subsystem can be found in Table 4-3A in Appendix 3. The nominal wind velocity was assumed to be a 150MPH with the flow being parallel to the ground. The velocity of 150 MPH encompasses the constraint of 100mph plus a 1.5 gust (safety) factor. A pressure distribution over the solar panel can be seen in Figure 9.

Table 4. Drag Force and Components.

Enclosure Subsystem	Pan-Tilt Subsystem	Solar Subsystem
225.22 lbf	68.39 lbf	76.71 lbf

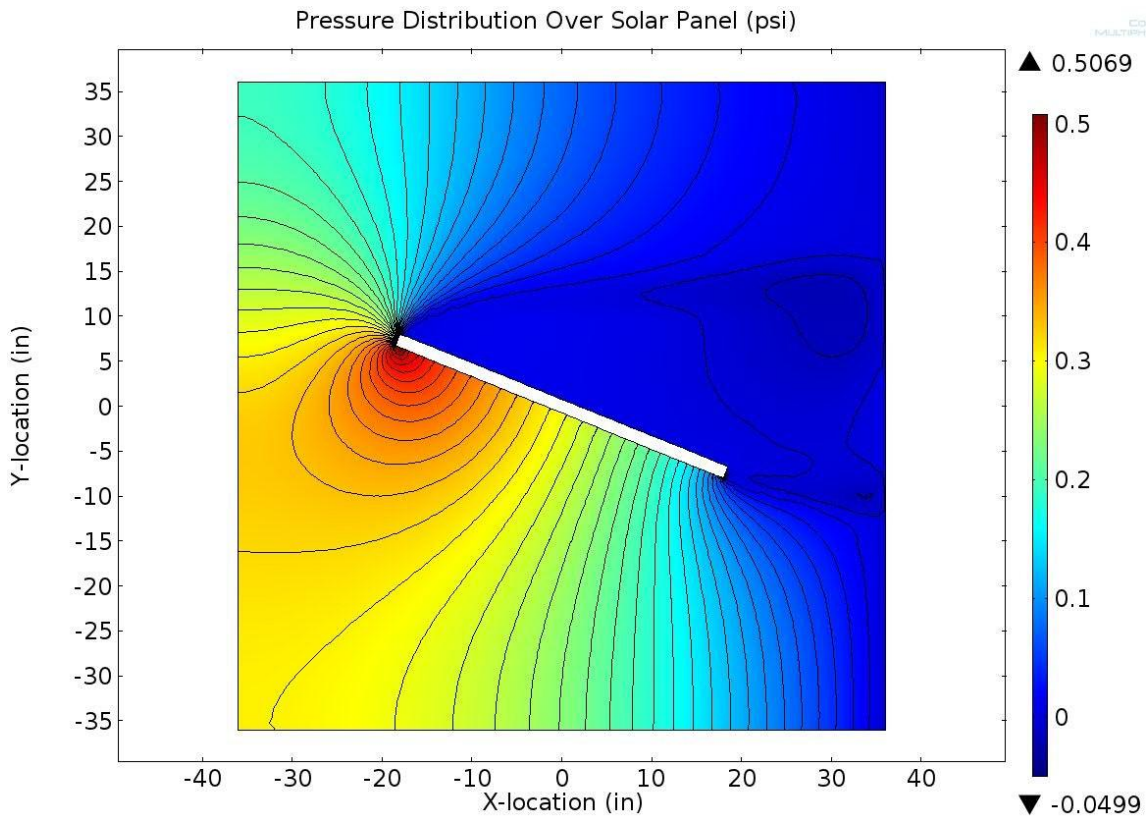

Figure 9. Wind Analysis on Solar Panel.

These drag forces were used to calculate the ground moment to ensure the pole was properly selected. Each individual component, including the pole itself contributes some net moment on the structure where it meets the ground. Table 4 shows the moment created from the wind load of each of mounted subsystems.

Table 5. Ground Moment Calculation.

Values	Enclosure Subassembly	Pan-Tilt Subassembly	Solar Subassembly	NET M (in*lb)
Wind Moment	3,603.52	2,735.6	4,986.2	11,612.12
Weight Moment	568.05	-480.70	199.5	

In summary, if the pole is to be buried at least 3 feet into concrete foundation with 6 feet being above grade. It is recommended however that the pole be fixed to existing structure so that there are several fixing points. This will disperse the forces experienced more evenly.

To ensure that the selected fasteners meet the demands of the system, loading simulations were conducted on the U-bolt and cap screw. In summary, both the U-bolt and the cap screws were loaded with the nominal shear and tensile loads expected from the enclosure and its mounting components. The loads caused by the enclosure and its contents were selected for simulation because they are the largest with a combined weight of approximately 82lbf. This force is shared between 4 cap screws and 2 U-bolts. The cap screw was tested with a shear load of 25lbf which is the approximate shared load expected from the enclosure assembly. This 25lbf load was placed at 0.5” from the base of the cap to simulate where the load of the enclosure acts on the screw. This simulation is shown in Figure 10 and shows a maximum Von Mises Stress of 5.115 ksi located near the base of the cap in red. When comparing this to the shear strength of stainless steel, the safety factor is 8.2. This high safety factor is completely sufficient enough.

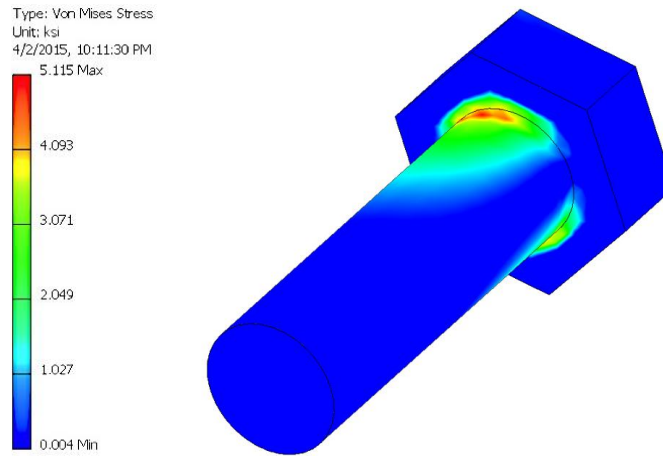

Figure 10. Cap screw under nominal 25lbf load.

The U-bolt selected for this project was cut in half for simulation. The applied shear load was once again 25lbf because the weight is shared by two U-bolts and each U bolt is simulated in half. Thus the load was split into 4. This shear load is applied centrally on the threads of the U-bolt. In contrast with the cap screw simulation, the U-bolt is also loaded in 45lbf of tension acting on each half of a U-bolt. This value was selected because it is more than enough tension to secure the weight of the enclosure assembly to the steel pole without allowing slip. After running the simulation seen in Figure 11, it was determined that the U-bolt would experience some small deformation as it was tightened due to a peak Von Mises Stress of 41.35 ksi. However the reaction forces acting on the U-bolt by the strut channel would ensure that the U-bolt maintains its shape. See Appendix 3 for more Final Design Analysis tables.

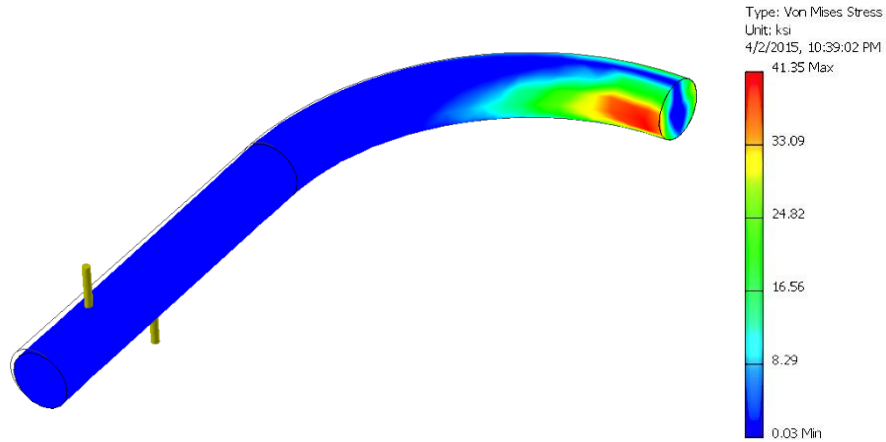

Figure 11. Half U-bolt simulated under nominal tension and shear.

To further ensure reliability of the mounting system, the 6ft, 2” O.D. carbon steel pole was compressively loaded with the tension required to hold each of the mounting subsystems in their proper place (Figure 12). That is, the solar panel U-bolts compress the pole with a minimum load of 28.5 lbf, the pan-tilt subassembly imposes a 25.3 lbf load, and the enclosure as mentioned previously, imposes a 90lbf load. In these simulations, it is assumed that the U-bolts and adjacent mounting items only touch the pole in two places. These locations of contact are assumed to be on opposite sides of the pole. In summary, the steel pole experiences no significant amount of stress due to the tension of the U-bolts on its surface. In fact the maximum simulate Von Mises Stress experienced by the pole is only about 0.04 psi.

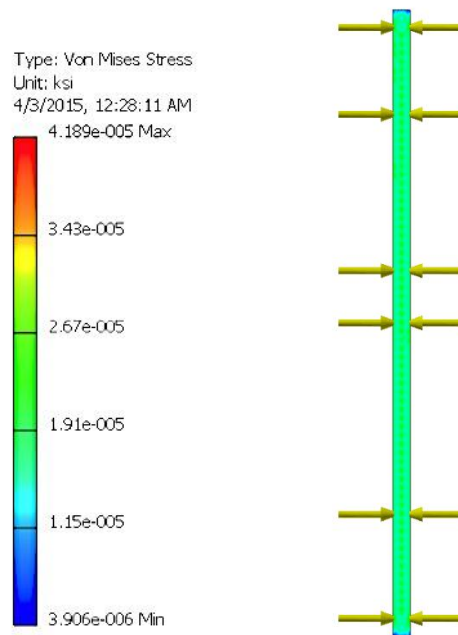

Figure 12. Steel pole compressed with subsystem loads.

IV. DESIGN FOR ECONOMICS

The economics of this project, although seeming like an obstacle at first, was not a limiting factor. The price point that our sponsor believed would make our system economical was at \$20,000. This became our design budget. Anything over was assumed to not be an economical replacement of the existing techniques. The budget then acquired for the prototype was \$3000. This large discrepancy was due to the fact that Siemens is mainly focused on a conceptual design and therefore is interested in a proof of concept prototype in lieu of an economically viable representation of our design. With this small proof of concept budget, it was decided to only prototype and procure the power system and monitoring system components. Below in Figure 13 is a comparison of our Design and Prototype Costs and Remaining Budgets. As you can see, both systems were under budget. The system design only uses 67% of the given budget while the prototype used 87%. A full list of components and costs can be found in Appendix 5: Bill of Materials.

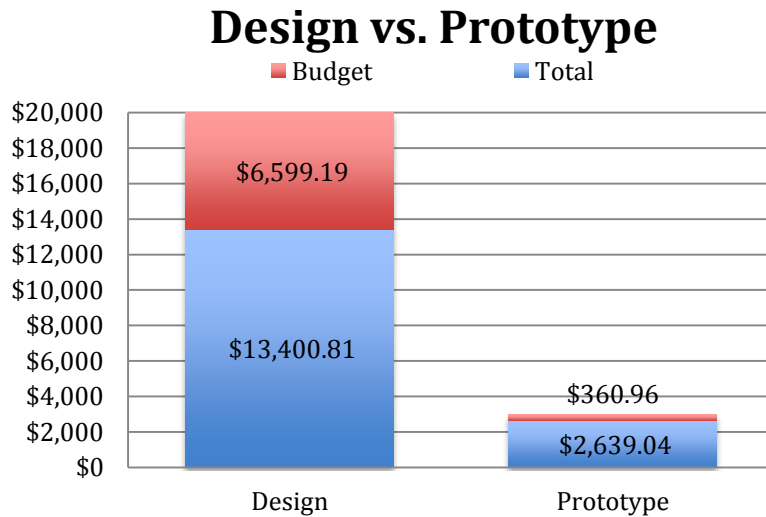

Figure 13. Design vs. Prototype Budgets.

Figure 14 demonstrates the cost breakdown of the expenditures for the designed system and the prototype. The most expensive component of the designed system was by far the FLIR infrared camera costing about \$10,115.61. The microcomputer and accessories then come in at 10% of costs with the pan-tilt module following at 5%. This goes along with what was previously mentioned about how the monitoring system was the focus of this project. These three components are the prime electronics of our system and were selected with accuracy. The caliber of these instruments is what separates our designed system from multiple systems already on the market. A comparison between the subsystem costs can be seen in Figure 15. In our prototype, since the camera was lent to us without cost, the most expensive component was the microcomputer and associated accessories. Overall we still had 12% of our prototype budget remaining at the end of procurement.

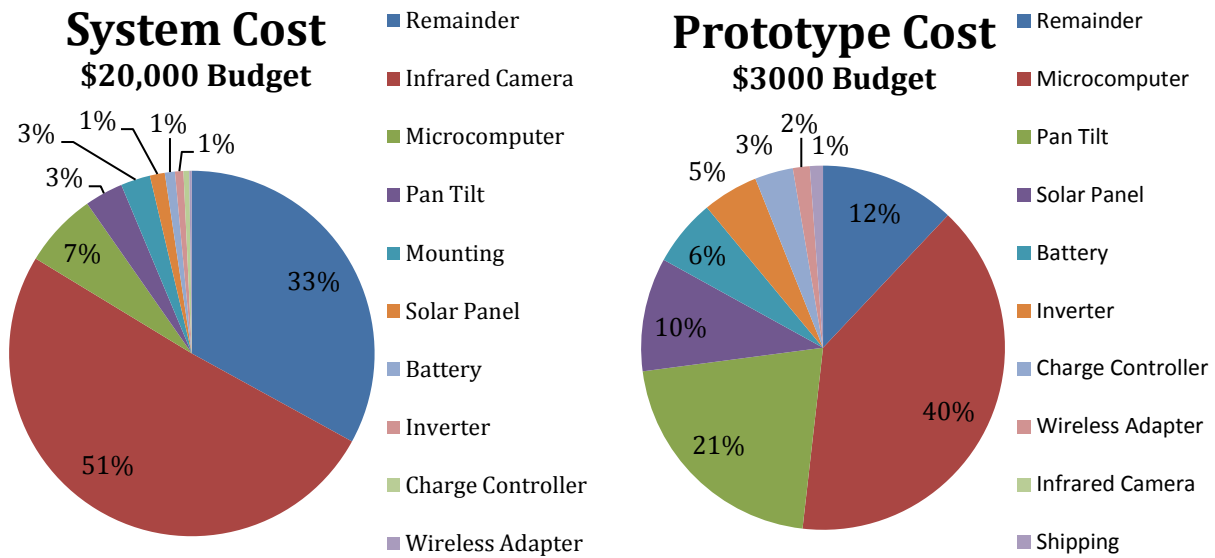

Figure 14. System Design and Prototype Cost Breakdown.

Design Sub-System Costs

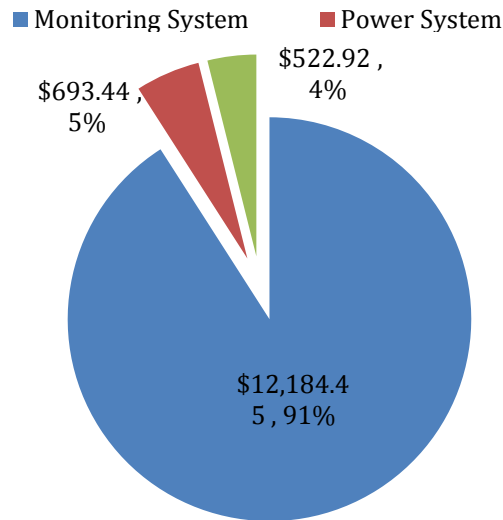

Figure 15. Design Sub-System Costs.

Below, in Figure 16, is a comparison of our system design cost to similar market options. A to Z Security provides some of the most Solar Power Wireless Security Systems on the market with varying scopes and prices. The system most similar to ours however is the Thermal Security Camera System (SS-TIRC). [10] It is a fully stand alone power system with an infrared camera but does not come with mounting equipment or battery storage. The 2MccTV Sony Network Camera System came in at a similar price of \$9,502.21 but came with battery storage and mounting but lacked an infrared camera. [11] Finally, the EcoKIT by MOOG was an interesting

market comparison because it too was very experimental by incorporating a wind power generator with the solar panel. This system, although complex, was the cheapest found but its price of \$5,173 did not include mounting or an infrared camera. [12] In conclusion, although our system is more expensive than available market options at \$13,392.22, it is one of a kind. No market option currently offers and Solar Wireless Infrared Monitoring System that is capable of high temperature substation monitoring. All systems found were purposed for mid-level surveillance and required further purchase of accessories.

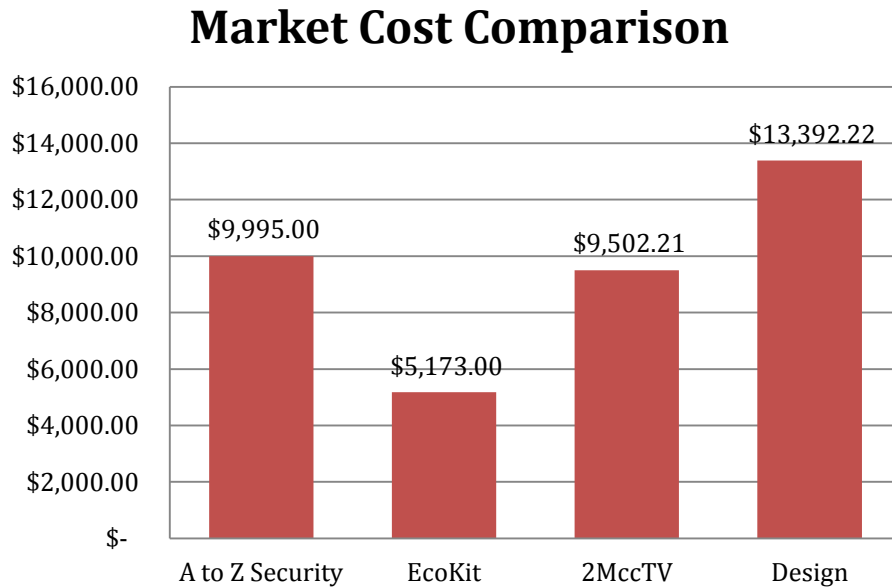

Figure 16. Market Competiveness.

V. CONCLUSION

The goal of this project was to design a Solar Wireless Infrared Monitoring System that could monitor the temperature of selected targets without interfering with the equipment, and consuming auxiliary power. A system was successfully designed that created a cost saving from the existing preventative maintenance techniques. The designed system also decreased the amount of manual labor needed to install and carry out equipment monitoring. This designed systems consisted of three subsystems; the Monitoring, Power, and Mounting System. A proof of concept prototype was created for the power and monitoring system. Both systems were procured, assembled, programmed, and tested. The final system product is a solid feasible design however there is room for optimization both technically, and economically. It is recommended that this project is continued another year for further optimization. More testing could be done on the power system and a better match between the solar panel and battery storage could be designed in order to decrease overall capacity. In addition, further programming work can be done to implement an alarm program and more detailed GUI for the operator. The programming could also be simplified more thorough investigation of other control methods. Finally, it is believed that the system could overall be made more economical through optimizing the total electronic circuit.

REFERENCES

- [1] Team 14, *SWIMS Project Website*.
http://www.eng.fsu.edu/me/senior_design/2015/team14/
- [2] Sharp, James. *Kickoff Meeting Proceedings: Siemens Energy Wireless IR Camera Study*.
http://www.eng.fsu.edu/me/senior_design/2015/team14/TeamFiles/KO_Presentation.pdf
- [3] Seminole Electric Cooperative. *R.J. Midulla Generating Station Brochure*.
http://www.seminole-electric.com/pdf/SGS_MGS_Brochure.pdf
- [4] Tiger Versallogic User Manual.
<http://www.versallogic.com/products/manuals/MEPM24.pdf>
- [5] YP3040 Pan Tilt Installation Manual.
http://www.axis.com/files/manuals/ig_yp3040_51012_en_1303.pdf
- [6] Mains Adapter Installation Manual. http://www.axis.com/files/manuals/26537r1_web.pdf
- [7] Infrared Camera User Manual. http://www.cylod.com/products/data_sheet/FLIR/A-series/A%20series.pdf
- [8] Charge Controller Installation Manual. <http://ecoworthy.com/catalog/download/20AMPPT.pdf>
- [9] Inverter Installation Manual. <http://www.batterystuff.com/files/manual-11001-pst-1500-2000-12-24-0513.pdf>
- [10] A and Z Security Cameras. *Solar Power Wireless Thermal Security Camera Systems SS-TIRC*. <http://www.a2zsecuritycameras.com/solar-power-thermal-security-camera-systems/>
- [11] 2MccTV. *Solar Powered Sony Network Camera System*.
http://www.2mccTV.com/product_info-2MCCTV2MSSFICH120.html?pn=877-875-5473&gclid=Cj0KEQjw6OOoBRDP9uG4oqzUv7kBEiQA0sRYBF74J8J2cRDZnO_yHktCx4bljtVKIOdpw5SAruGpWgIaAjuj8P8HAQ
- [12] EcoKIT. *Remote Solar and Wind Power Generator for Surveillance Systems*.
<http://www.surveillance-video.com/media/lanot/attachments/customimport/ECOKIT.pdf>

APPENDIX 1: COMPONENT SPECIFICATION DATASHEETS

A. INFRARED CAMERA



Technical Data

FLIR A310f 25°

Part number:
61201-1103

Copyright

© 2012, FLIR Systems, Inc.

All rights reserved worldwide. Names and marks appearing herein are either registered trademarks or trademarks of FLIR Systems and/or its subsidiaries. All other trademarks, trade names or company names referenced herein are used for identification only and are the property of their respective owners.

March 08, 2012, 07:56 AM

Corporate Headquarters

FLIR Systems, Inc.
27700 SW Parkway Ave.
Wilsonville, OR 97070
USA
Telephone: +1-503-498-3547

Website

<http://www.flir.com>

Customer support

<http://support.flir.com>

Legal disclaimer

Specifications subject to change without further notice. Camera models and accessories subject to regional market considerations. License procedures may apply.

Information and equipment described herein may require US Government authorization for export purposes. Diversion contrary to US law is prohibited.

**Imaging and optical data**

IR resolution	320 × 240 pixels
Thermal sensitivity/NETD	< 0.05°C @ +30°C (+86°F) / 50 mK
Field of view (FOV) / Minimum focus distance	25° × 18.8° / 0.4 m (1.31 ft.)
Focal length	18 mm (0.7 in.)
Spatial resolution (IFOV)	1.36 mrad
Lens identification	Automatic
F-number	1.3
Image frequency	30 Hz
Focus	Automatic or manual (built in motor)
Zoom	1–8× continuous, digital, interpolating zooming on images

Detector data

Focal Plane Array (FPA) / Spectral range	Uncooled microbolometer / 7.5–13 μm
Detector pitch	25 μm
Detector time constant	Typical 12 ms

Measurement

Object temperature range	–20 to +120°C (–4 to +248°F) 0 to +350°C (+32 to +662°F)
Accuracy	±4°C (±7.2°F) or ±4% of reading

Measurement analysis

Spotmeter	10
Area	10 boxes with max./min./average/position
Isotherm	1 with above/below/interval
Measurement option	Measurement Mask Filter Schedule response: File sending (ftp), email (SMTP)
Difference temperature	Delta temperature between measurement functions or reference temperature
Reference temperature	Manually set or captured from any measurement function
Atmospheric transmission correction	Automatic, based on inputs for distance, atmospheric temperature and relative humidity
Optics transmission correction	Automatic, based on signals from internal sensors
Emissivity correction	Variable from 0.01 to 1.0
Reflected apparent temperature correction	Automatic, based on input of reflected temperature
External optics/windows correction	Automatic, based on input of optics/window transmission and temperature
Measurement corrections	Global and individual object parameters

Alarm

Alarm functions	6 automatic alarms on any selected measurement function, Digital In, Camera temperature, timer
-----------------	--



FLIR A310f 25°

P/N: 61201-1103

© 2012, FLIR Systems, Inc.
All rights reserved worldwide.

Alarm	
Alarm output	Digital Out, log, store image, file sending (ftp), email (SMTP), notification
Set-up	
Color palettes	Color palettes (BW, BW inv, Iron, Rain)
Set-up commands	Date/time, Temperature°C/°F
Storage of Images	
Storage media	Built-in memory for image storage
File formats	Standard JPEG, 16-bit measurement data included
Ethernet	
Ethernet	Control, result and image
Ethernet, type	100 Mbps
Ethernet, standard	IEEE 802.3
Ethernet, connector type	RJ-45
Ethernet, communication	TCP/IP socket-based FLIR proprietary
Ethernet, video streaming	MPEG-4, ISO/IEC 14496-1 MPEG-4 ASP@L5
Ethernet, image streaming	16-bit 320 x 240 pixels @ 7-8 Hz - Radiometric
Ethernet, power	Power over Ethernet, PoE IEEE 802.3af class 0
Ethernet, protocols	Ethernet/IP, Modbus TCP, TCP, UDP, SNMP, RTSP, RTP, HTTP, ICMP, IGMP, ftp, SMTP, SMB (CIFS), DHCP, MDNS (Bonjour), uPnP
Digital input/output	
Digital input, purpose	Image tag (start/stop/general), Input ext. device (programmatically read)
Digital input	2 opto-isolated, 10–30 VDC
Digital output, purpose	As function of ALARM, Output to ext. device (programmatically set)
Digital output	2 opto-isolated, 10–30 VDC, max 100 mA
Digital I/O, isolation voltage	500 VRMS
Digital I/O, supply voltage	12/24 VDC, max 200 mA
Digital I/O, connector type	6-pole jackable screw terminal
Composite video	
Video out	Composite video output, PAL and NTSC compatible
Video, standard	CVBS (ITU-R-BT.470 PAL/SMPT 170M NTSC)
Power system	
External power operation	12/24 VDC, 24 W absolute max
External power, connector type	2-pole jackable screw terminal
Voltage	Allowed range 10–30 VDC
Environmental data	
Operating temperature range	–25°C to +50°C (–13°F to +122°F)
Storage temperature range	–40°C to +70°C (–40°F to +158°F)
Humidity (operating and storage)	IEC 60068-2-30/24 h 95% relative humidity +25°C to +40°C (+77°F to +104°F)
EMC	<ul style="list-style-type: none"> EN 61000-6-2 (Immunity) EN 61000-6-3 (Emission) FCC 47 CFR Part 15 Class B (Emission)
Encapsulation	IP 66 (IEC 60529)
Bump	5 g, 11 ms (IEC 60068-2-27)
Vibration	2 g (IEC 60068-2-6)



FLIR A310f 25°

P/N: 61201-1103
 © 2012, FLIR Systems, Inc.
 All rights reserved worldwide.

Physical data

Weight	5 kg (11.0 lb.)
Size (L x W x H)	460 x 140 x 159 mm (18.1 x 5.5 x 6.3 in.)
Base mounting	TBA
Housing material	Aluminum

System features

External power operation (heater)	24 VDC 25 W max w/heater @ 24 VDC
External power, connector type (heater)	2-pole jackable screw terminal
Voltage (heater)	Allowed range 21-30 VDC
Automatic heaters	Clears window from ice

- Scope of delivery**
- Cardboard box
 - Infrared camera with lens and environmental housing
 - Calibration certificate
 - Downloads brochure
 - FLIR Sensors Manager CD-ROM
 - Lens cap
 - Printed Getting Started Guide
 - Printed Important Information Guide
 - Service & training brochure
 - Small accessories kit
 - User documentation CD-ROM
 - FLIR Tools & Utilities CD-ROM
 - Registration card
-

B. PAN-TILT MODULE

www.axis.com

Technical Specifications - YP3040 Pan-Tilt Motor

Models	YP3040 Pan-Tilt Motor	Power	Consumption: 30 W Input: 24 V AC 50/60 Hz AXIS PS-24 Mains Adaptor recommended (not included)
General		Operating conditions	-20 °C to 65 °C (-4 °F to 149 °F)
Supported cameras	AXIS P13-E, AXIS Q16-E, AXIS Q1755-E and AXIS Q1765-LE PT Mount Network Cameras, AXIS Q1910-E, AXIS Q1922-E, AXIS Q1931-E PT Mount and AXIS Q1932-E PT Mount Thermal Network Cameras, AXIS T92A and AXIS T92E Housings	Approvals	IEC/EN 60529 IP66
Pan/Tilt/Zoom	Pan range 0° to 355° Tilt range 10° to -80° Pan speed 7.5°/s Tilt speed 6°/s Designed for operator control	Dimensions	288 x 165 x 188.5 mm (11 x 6 x 7 in)
Casing	Aluminum alloy Color: White NCS S 1002-B	Weight	4,2 kg (9 lb)
Supported protocols	Pelco-D	Included accessories	Mounting kit, Drill template, Installation guide
Connectors	1x RS485 port	Optional accessories	AXIS T8310 Video Surveillance Control Board, YP3040 Wall Bracket, AXIS T92A20 Housing, AXIS T92E05 Housing, AXIS T92E20 Housing, AXIS PS-24 Mains Adaptor
Mounting	Wall mounting Torque: 1.5 N m (1,1 lb ft) Maximum load: 8 kg (17.6 lb)	Warranty	Axis 1-year warranty, www.axis.com/warranty

More information is available at www.axis.com

57018/EN/MA3.2/092014

Dimensions

- YP3040 Pan-Tilt Motor
- YP3040 Wall Bracket

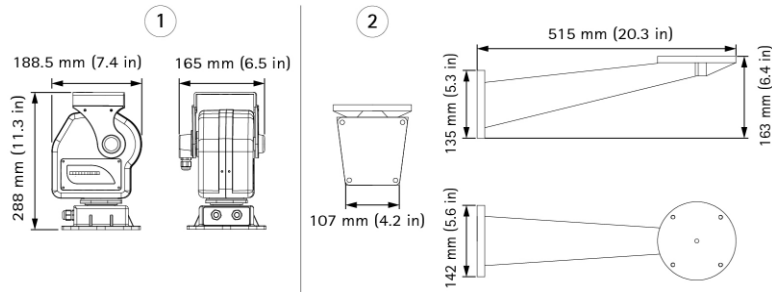

Optional accessories

- YP3040 Wall Bracket
- Axis housings
- AXIS T8310 Video Surveillance Control Board
- AXIS PS-24 Mains Adaptor



©2014 Axis Communications AB. AXIS COMMUNICATIONS, AXIS, ETRAX, ARTPEC and VAPIX are registered trademarks or trademark applications of Axis AB in various jurisdictions. All other company names and products are trademarks or registered trademarks of their respective companies. We reserve the right to introduce modifications without notice.



C. MICROCOMPUTER



TIGER

PC/104-Plus Single Board Computer

is critical in many OEM applications.

The Tiger features an embedded BIOS with OEM enhancements from Phoenix Technologies. The field-reprogrammable BIOS supports custom defaults and the addition of firmware applications for security processes, remote booting, and other pre-OS software functions. The Tiger is compatible with a variety of popular operating systems including Windows, Windows Embedded, Linux, VxWorks, and QNX.

Ordering Information

Model	Processor	Speed	Operating Temp.	Cooling
VL-EPM-24SU	Intel Atom Z530P	1.6 GHz	0° to +60°C	Fanless
VL-EPM-24EU	Intel Atom Z520PT	1.33 GHz	-40° to +85°C	Fanless

Accessories

Part Number	Description
VL-CKR-TIGER	Development cable kit. <i>Includes bold items below.</i>
VL-CBR-1008	ATX power adapter cable
VL-CBR-2012	20" 24-bit LVDS flat panel cable (Hirose)
VL-CBR-2014	LVDS to VGA adapter board
VL-CBR-4405	IDE adapter board
VL-CBR-4406	IDE cable
VL-CBR-5012	I/O cable set and paddleboard
VL-HDW-105	0.6" standoff package (metric thread)
VL-CBR-1401	Cable assembly for (2) SPX modules
VL-CBR-1402	Cable assembly for (4) SPX modules
VL-CBR-1603	Quad USB transition cable
VL-CBR-2010	20" 18-bit LVDS flat panel cable (Hirose)
VL-CBR-2011	20" 18-bit LVDS flat panel cable (JAE)
VL-CDD-xxxx	CD-RW/DVD-ROM drive
VL-ENCL-5D	Development enclosure
VL-F20-xxxx	Disk on Module (IDE)
VL-HDD25-xxx	2.5" hard drive (IDE)
VL-HDW-106	0.6" standoff package (English thread)
VL-HDW-108	DOM hardware kit (metric thread)
VL-HDW-203	PC/104 extractor tool, metal
VL-MM8-xxxx	DDR2 RAM module
VL-PS200-ATX	200W ATX-style development power supply
VL-SPX-x	SPX expansion modules

* Power specifications represent operation at +25°C with +5V supply running Windows XP with 2 GB RAM, Ethernet, keyboard, and mouse. Typical power computed as the mean value of Idle and Maximum power specifications. Maximum power is measured with 95% CPU utilization.

† Signal lines on this port are TVS protected (enhanced ESD protection)

‡ Power pins on this port are overload protected

Specifications are subject to change without notification. Intel and Atom are trademarks of Intel Corp. SpeedStep is a registered trademark of Intel Corp. SPX is a trademark of VersaLogic Corp. All other trademarks are the property of their respective owners.

02/20/13

SPECIFICATIONS

General	Board Size			
Processor + Chipset	Model	Processor	Speed	Chipset
	VL-EPM-24SU	Atom Z530P	1.6 GHz	US15WP
Power Requirements *	Model	Processor	Speed	Chipset
	VL-EPM-24EU	Atom Z520PT	1.33 GHz	US15WPT
Hardware Monitors	533 MHz FSB. Dynamic 512 KB L2 cache. Supports Enhanced Intel SpeedStep Technology and Hyper-Threading Technology (HTT).			
	Model	Sleep (S3)	Typical	
	VL-EPM-24SU	0.21A (1.05W)	1.20A (6.0W)	
Stackable Bus	VL-EPM-24EU	0.23A (1.15W)	1.18A (5.9W)	
	Watchdog Timer: 1 second to 255 minutes. Warm reset, cold reset, or power down.			
Other I/O Expansion	Power Quality Monitor: System reset on undervoltage conditions			
	RoHS: Compliant			
Environmental	Operating Temperature			
Storage Temperature	Model	Operating Temperature		
	VL-EPM-24SU	0° to +60°C		
Airflow Requirements	VL-EPM-24EU	-40° to +85°C		
	Model	Airflow Requirements		
Thermal Shock	VL-EPM-24SU	Free air from 0° to +60°C		
	VL-EPM-24EU	100 LFPM from +60° to +85°C		
Humidity	5°C/min. over operating temperature			
	Less than 95%, noncondensing			
Vibration, Sinusoidal Sweep	MIL-STD-202G, Method 204, Modified Condition A: 2g constant acceleration from 5 to 500 Hz, 20 minutes per axis			
	MIL-STD-202G, Method 214A, Condition A: 5.35g rms, 5 minutes per axis			
Mechanical Shock	MIL-STD-202G, Method 213B, Condition G: 20g half-sine, 11 ms duration per axis			
	Memory			
Video	System RAM			
	SO-DIMM socket. Up to 2 GB DDR2 SDRAM.			
Mass Storage	General			
	Integrated high-performance video. Intel GMA 500 graphics core supports advanced 3D graphics and high-definition video decode.			
	VRAM			
	Up to 256 MB shared DRAM			
Network Interface	OEM Flat Panel Interface			
	18/24-bit LVDS interface. CMOS-selectable TFT panel types. Up to 1280 x 1024 (24 bits) @ 85 Hz.			
Device I/O	Desktop Display Interface			
	Analog output (VGA) via optional adapter cable †			
Software	Hard Drive			
	IDE controller (ATA-6, UDMA/100) supports two IDE devices			
Operating Systems	Flash			
	Right angle IDE Disk on Module (DOM) site with retention screw			
BIOS	Ethernet †			
	Autodetect 10BaseT/100BaseTX/1000BaseT port			
Sleep Mode	Network Boot Option			
	Intel boot agent (downloadable) supports PXE protocol. Argon Managed Boot Agent (optional with royalty fee) supports PXE, RPL, NetWare, TCP/IP (DHCP, BOOTP) remote boot protocols.			
ACPI 2.0 compatible	USB ††			
	Seven USB 2.0/1.1 ports (one client, six host)			
Compatible with most x86 operating systems including Windows, Windows Embedded, Linux, VxWorks, and QNX	COM 1/2/3/4 †			
	RS-232/422/485 selectable. 16C550 compatible. 460 Kbps.			
Audio				
Intel High Definition Audio (HDA) compatible. Stereo line in/out.				

VersaLogic Corporation • 12100 SW Tualatin Rd., Tualatin, OR 97062 • (503) 747-2261 • Info@VersaLogic.com • www.VersaLogic.com

D. WIRELESS COMMUNICATION

NETGEAR®

N600 WiFi Dual Band USB Adapter

Data Sheet

WNDA3100



Performance & Use

- N600**
 - Dual band avoids interference for reliable connections
 - Faster WiFi speeds 300/300 - Up to 600 Mbps†
 - Works with any WiFi router or modem router
-

The NETGEAR Difference - WNDA3100



- Faster downloads
- Push 'N' Connect—push button security
- Reliable and compatible
- Easy setup with NETGEAR® genie®

Overview

The NETGEAR N600 Wireless Dual Band USB Adapter wirelessly connects your notebook or desktop computer to a Wireless-N network for applications, such as HD video streaming, online gaming, a secure and reliable connection to the Internet. NETGEAR genie® is included for easy installation. WiFi dual band technology avoids interference for reliable connections. With the NETGEAR Push 'N' Connect feature, enjoy a secured wireless Internet connection, at the push of a button.

PUSH 'N' CONNECT—WPS

A secured connection at the push of a button¹

STEP 1	STEP 2	STEP 3
Install CD and push the button on the adapter 	Push the Push 'N' Connect button on the router 	Secure wireless connection 

¹ Works with devices supporting Wi-Fi Protected Setup® (WPS).

E. MPPT CHARGE CONTROLLER



www.eco-worthy.com
Email: info@eco-worthy.com

- Low stand-by power consumption

Specifications

Item No.	ECO-MPPT-20A
Rated system voltage	12V/24V DC
Max open circuit voltage of solar panel	15—50V DC
Max solar panel power	300W 12V/ 600W 24V
Max output current	20A
Max discharge current	20A
Over discharge voltage	10.2—12.5V (±0.2) 12V/ 20.4—25.0V (±0.2) 24V
Restart voltage	10.3—13.5V (±0.2) 12V /20.5—27.0V (±0.2) 24V
Constant voltage (Over charge) voltage	13.0—15.5V (±0.2) 12V / 26.0—31.0V (±0.2) 24V
Float voltage	12.5—14.5V (±0.2) 12V / 25.0—29.0V (±0.2) 24V
Converter type	Buck
Converter efficiency	> 96%
Max increase efficiency	> 43%
Tracking efficiency	> 98%
Precision of clock	±50S/Month
Charging algorithm	PWM 3 stage
Stand by power consumption	<15mA 12V / <25mA 24V
Operating temperature	-20 to +50℃
Protect class	IP22
Size	140(L) × 147(W) × 42(H) (mm)
Weight	550g

★(1) Max input current : Solar panel maximum output current

★(1) Max output current : Controllers maximum output current

Wiring diagram

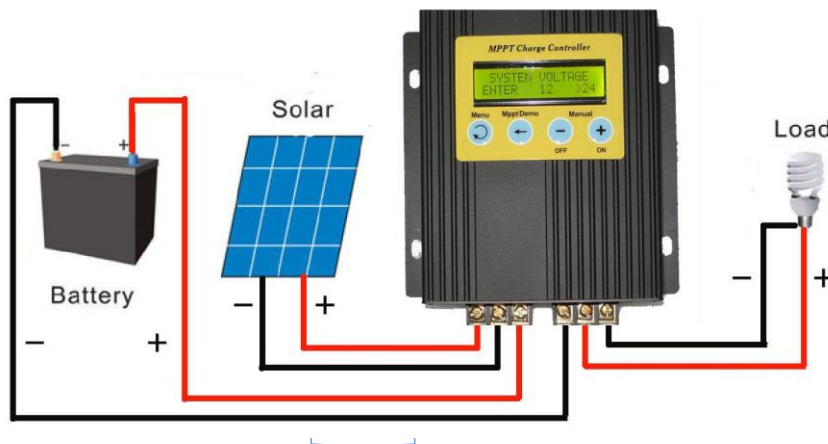

F. INVERTER



DC-AC Inverter Pure Sine Wave	Model
	SA-150-112 12 VDC-110 VAC
	SA-150-124 24 VDC-110 VAC

Design Features

- Pure sine wave output (THD < 6%)
- Switch selectable output frequency: 50 / 60 Hz
- Remote ON/OFF control using external mechanical / transistor switch
- Input and output are fully isolated
- Advanced micro-controller
- Load controlled cooling fans save power consumption
- Tri-color LED for display of operational status and fault indications
- **Protections:** overload, short-circuit, leakage, low and high DC input voltages, high temperature and reverse polarity
- **Safety:** Listed to UL Standard UL-458
- **EMC:** Complies with FCC Part 15(B), Class B

2 YEAR WARRANTY



	MODEL NO.	SA-150-112	SA-150-124
OUTPUT	OUTPUT VOLTAGE	110 VAC, ± 5%	110 VAC, ± 5%
	OUTPUT FREQUENCY	50 / 60 Hz ± 0.3% (Selected by Switch)	50 / 60 Hz ± 0.3% (Selected by Switch)
	TYPE OF OUTPUT WAVEFORM	Pure Sine Wave	Pure Sine Wave
	TOTAL HARMONIC DISTORTION OF OUTPUT WAVEFORM	< 6%	< 6%
	CONTINUOUS OUTPUT POWER (At Power Factor = 1)	150W	150W
	SURGE OUTPUT POWER (At Power Factor = 1)	200W	200W
	PEAK EFFICIENCY (At full load)	87%	88%
	AC OUTPUT CONNECTIONS	Dual NEMA-15R receptacles with GFCI protection	
INPUT	NOMINAL DC INPUT VOLTAGE	12 VDC	24 VDC
	DC INPUT VOLTAGE RANGE	10.5 to 15 VDC	21.0 to 30 VDC
	DC INPUT CURRENT AT NO LOAD	0.3A	0.35A
	DC INPUT CONNECTIONS	Detachable pair of wires with Anderson Power Pole Connectors on inverter side	
DISPLAY	STATUS OPERATIONS & PROTECTIONS	By steady / flashing patterns of 3 - color LED	
REMOTE OPERATION	WIRED ON/OFF CONTROL	By external contact closure through mechanical / transistor switch	
PROTECTIONS	LOW DC INPUT VOLTAGE SHUTDOWN	10.5 VDC	21.0 VDC
	HIGH DC INPUT VOLTAGE SHUTDOWN	15.3 VDC	30.6 VDC
	SHORT CIRCUIT SHUTDOWN	Yes	Yes
	OVERLOAD SHUTDOWN	Yes	Yes
	GROUND FAULT SHUTDOWN	GFCI protected dual NEMA5-20R receptacles	
	OVER TEMPERATURE SHUTDOWN	Yes	Yes
COOLING	REVERSE POLARITY ON DC INPUT SIDE	Yes. Internal fuses will blow.	Yes. Internal fuses will blow.
	FORCED AIR COOLING	Thermostatically controlled fan	Thermostatically controlled fan
COMPLIANCE	SAFETY	UL Listed to UL-458	UL Listed to UL-458
	EMI / EMC	Meets FCC Part 15(B), Class A	Meets FCC Part 15(B), Class A
ENVIRONMENT	OPERATING TEMPERATURE RANGE	0°C to +40°C / 32°F to 104°F	0°C to +40°C / 32°F to 104°F
	STORAGE TEMPERATURE RANGE	-30°C to 70°C / -22°F to 158°F	-30°C to 70°C / -22°F to 158°F
DIMENSIONS	(L X W X H), MM	200 x 132 x 72	200 x 132 x 72
	(L X W X H), INCHES	7.9 x 5.2 x 2.8	7.9 x 5.2 x 2.8
WEIGHT	KG	2.7	2.7
	LBS	5.6	5.6

NOTE: Specifications are subject to change without notice

12003-SA-150-112-124-1112

To view a full selection of Samlex products visit our website at www.samlexamerica.com or contact us: 1(800) 561-5885 or sales@samlexamerica.com

G. POE SPLITTER



PoE Splitter, Fast Ethernet, 1 Port

There are no reviews yet. | [Write a review](#)



NT1-3195-R

Availability: **In Stock**

Ships Within 1-3 Business Days



\$23.19

Quantity:

Add to Cart

[Estimate Shipping](#)



[Description](#)

[Features](#)

[Specifications](#)

[Reviews \(0\)](#)

Specs:

Standards and Protocols	IEEE 802.3, 802.3u, 802.3af CSMA/CD, TCP/IP	
Basic Function	Compatible with IEEE 802.3af compliant PSEs Delivers power up to 100 meters Optional 12VDC or 5VDC power supply Plug-and-Play	
Ports	LAN Port	1 10/100M Auto-Negotiation RJ45 port (Auto MDI/MDIX)
	PoE Port	1 10/100M Auto-Negotiation RJ45 port (Auto MDI/MDIX)
Network Media	10BASE-T: UTP category 3, 4, 5 cable (maximum 100m) EIA/TIA-568 100Ω STP (maximum 100m) 100BASE-TX: UTP category 5, 5e cable (maximum 100m) EIA/TIA-568 100Ω STP (maximum 100m)	
LED Indicator	PWR	
Safety & Emission	FCC, CE	
Dimensions (W*D*H)	3.2*2.0*0.9 in.(81*52*24 mm)	
Environment	Operating Temperature: 0°C-40°C (32°F-104°F) Storage Temperature: -40°C-70°C (-40°F-158°F) Operating Humidity: 10%-90% non-condensing Storage Humidity: 5%-90% non-condensing	
Power Output	12W (12VDC) or 11.5W (5VDC)	

H. SOLAR PANEL

RNG-150D

Key Features

- Top Ranked PTC Rating
- High Module Conversion Efficiency
- Fast and Inexpensive Mounting
- Maximizes System Output by Reducing the mismatch Loss
- 100% EL Testing on Every Renogy Modules, Guaranteed No Hot Spot
- Guaranteed Positive Output Tolerance (0+3%)
- Withstands High Wind (2400 Pa) and Snow Loads (5400 Pa)
- Excellent Performance in Low Light Environments

Application

- Off-Grid Rooftop/Ground Mounted
- Residential/Rural
- 12 V Battery Charging

Electrical Characteristics

Maximum Power at STC (Pmax)	150 W
Optimum Operating Voltage (Vmp)	17.9 V
Optimum Operating Current (Imp)	8.38 A
Open-Circuit Voltage (Voc)	22.5 V
Short-Circuit Current (Isc)	9.05 A
Cells Efficiency	19.0%
Maximum System Voltage	

Mechanical Characteristics

Solar Cell	Monocrystalline 156 x 16mm
No. of Cells	36 (6 x 6)
Dimensions	1000 x 990 x 35 mm (39.5 x 39 x 1.4 inches)
Weight	11.5 kgs (25.5 lbs)
Front Glass	3.2 mm (0.13 inches) tempered glass
Frame	Anodized aluminum alloy
Junction Box	IP65 rated
Output Cables	4.0 mm ² (0.006 inches ²), 1000mm (39.3 inches)
Connectors	MC4 connectors
Fire Rating	Class C



Module Diagram

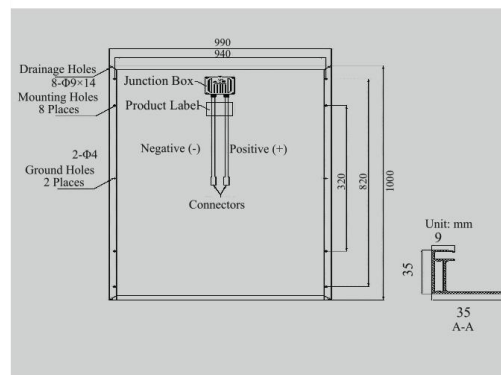

Maximum Ratings

Operating Module Temperature	-40°C to +80°C
Maximum Series Fuse Rating	15 A

Temperature Characteristics

Nominal Operating Cell Temperature (NOCT)	47±2°C
Temperature Coefficient of Pmax	-0.44%/°C
Temperature Coefficient of Voc	-0.30%/°C
Temperature Coefficient of Isc	0.04%/°C

©2013 Renogy,LLC. All rights reserved. Contents included in this datasheet are subject to change without notice.

I. BATTERY



Sealed Lead-Acid Batteries

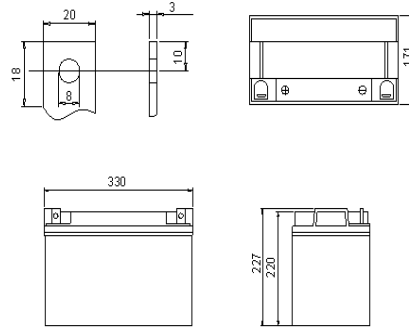

● Specifications

Nominal Voltage		12V
Rated Capacity 77°F(25°C) (10HR)		100.0Ah
Dimensions (mm/inch)	Length	330 (12.99)
	Width	171 (6.73)
	Height	220 (8.66)
	Total Height	227 (8.94)
Approx. Weight (kg/lbs)		30.6 (67.46)
Terminal		T6/T12

● Characteristic

Capacity 77°F(25°C)	20HR (5.30A)	106.0Ah
	10HR (10.0A)	100.0Ah
	5HR (17.0A)	85.0Ah
	1HR (55.0A)	55.0Ah
	15 min rate (175.0A)	43.8Ah
Internal Resistance	Full Charged Battery 77°F(25°C)	Approx. 5mΩ
	104°F(40°C)	102%
Temperature dependence of capacity (10HR)	77°F(25°C)	100%
	32°F(0°C)	85%
	5°F(-15°C)	65%
Self-Discharge 68°F(20°C) (Capacity after)	3 months	90%
	6 months	80%
	12 months	60%
Max. Discharge Current, 77°F(25°C)		800A(5s)
Floating design life, 77°F(25°C)		10 years
Constant Voltage Charge, 77°F(25°C)	Cycle	14.4~14.7V(-24mV/°C) max. current: 25 A
	Float	13.6~13.8V(-18mV/°C)

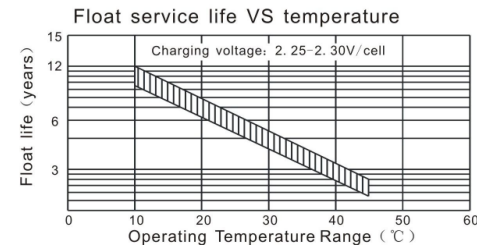
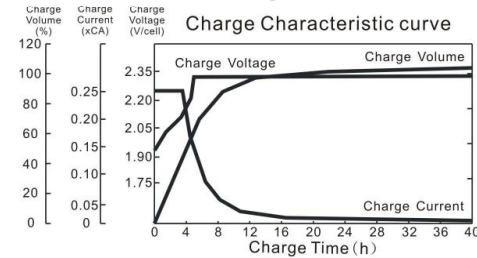
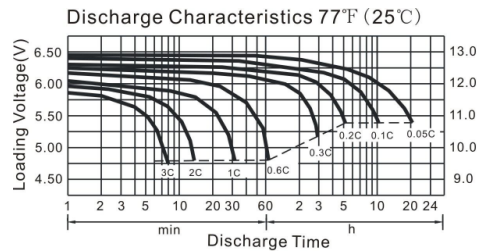

Constant Current Discharge Characteristics (A), 77°F(25°C)

F.V/TIME	5min	10min	15min	30min	60min	2H	3H	5H	8H	10H	20H
1.60V/cell	340.0	220.0	175.0	100.0	58.1	36.03	26.56	17.95	12.00	10.43	5.45
1.70V/cell	323.0	209.0	167.1	95.6	56.0	34.65	25.95	17.62	11.88	10.33	5.40
1.75V/cell	308.0	196.0	164.1	93.6	55.0	34.00	25.44	17.30	11.63	10.15	5.35
1.80V/cell	289.0	181.0	161.2	91.8	54.1	33.41	25.00	17.00	11.50	10.00	5.30

Constant Wattage Discharge Characteristics (Watt), 77°F(25°C)

F.V/TIME	5min	10min	15min	30min	60min	2H	3H	5H	8H	10H	20H
1.60V/cell	603.5	399.7	320.8	184.2	107.5	67.26	50.02	34.11	23.00	20.34	10.63
1.70V/cell	578.7	383.2	309.1	177.7	104.5	65.26	49.31	33.77	22.97	20.32	10.62
1.75V/cell	557.0	362.6	306.3	175.6	103.6	64.60	48.76	33.44	22.68	20.13	10.61
1.80V/cell	527.4	337.9	303.6	173.7	102.8	64.04	48.33	33.15	22.62	20.00	10.60

APPENDIX 2: POWER SYSTEM HOMER ANALYSIS

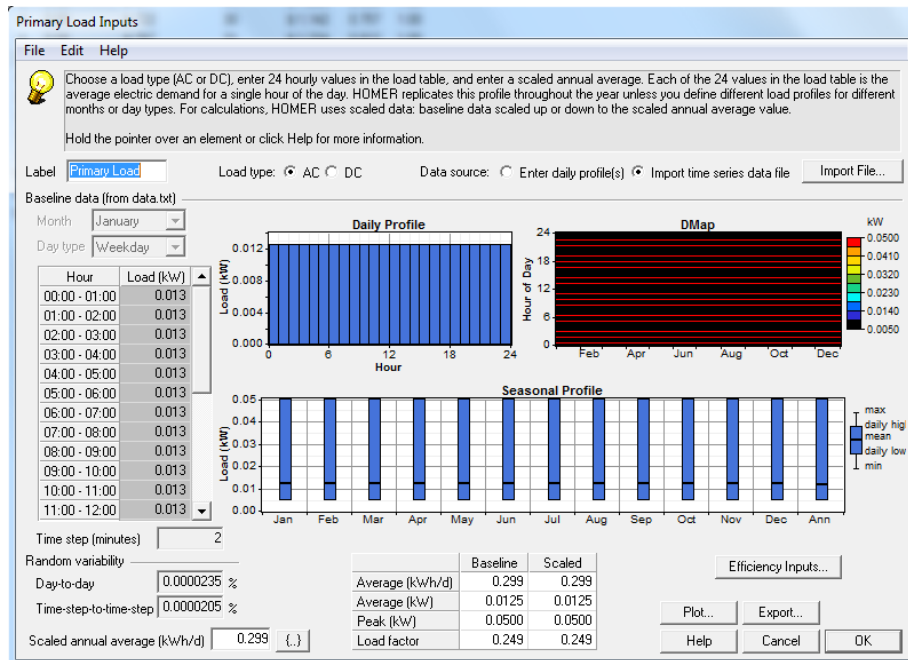

Figure 17. Daily Load Profile Input.

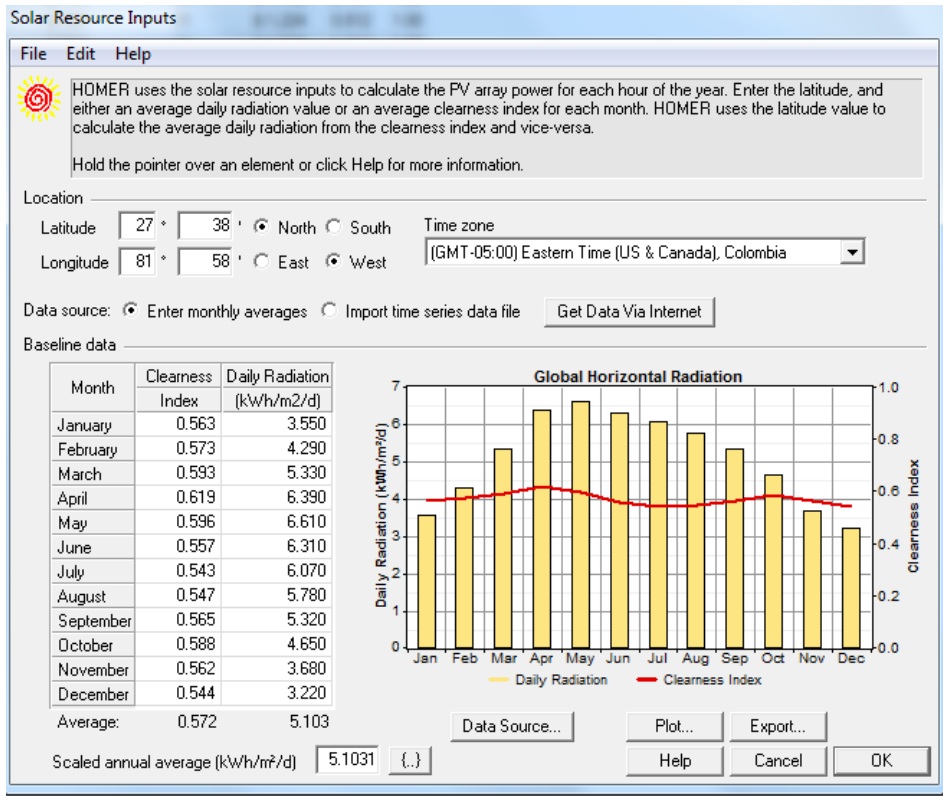

Figure 18. Solar Resource Input.

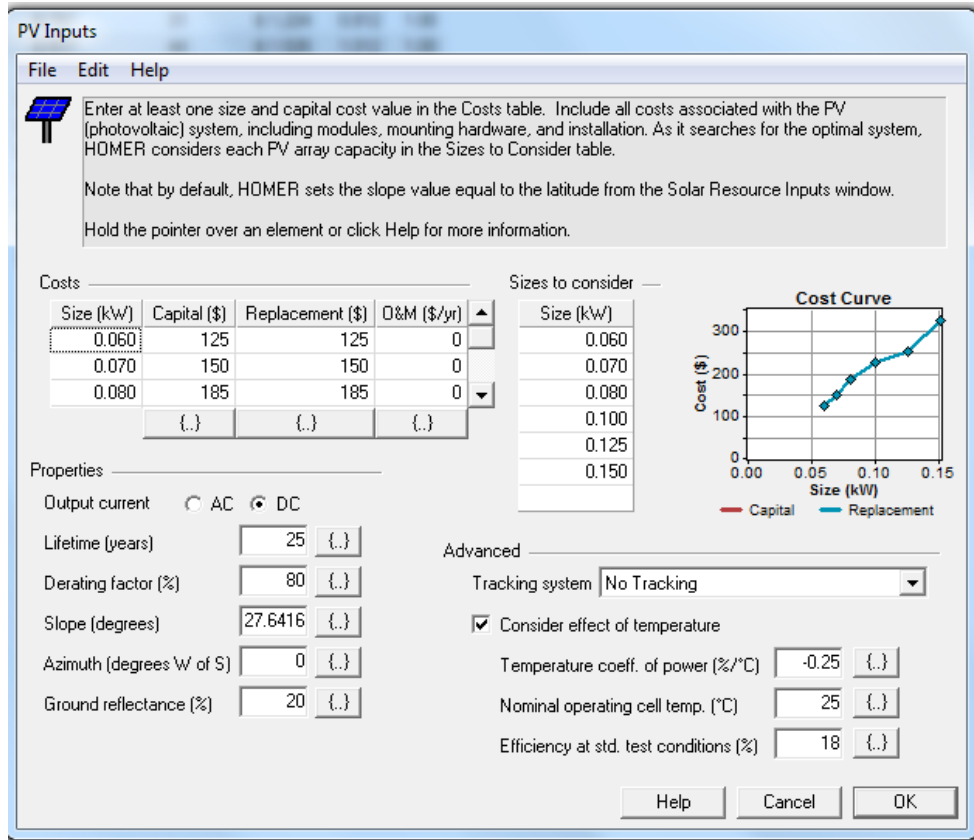

Figure 19. PV Panel Settings.

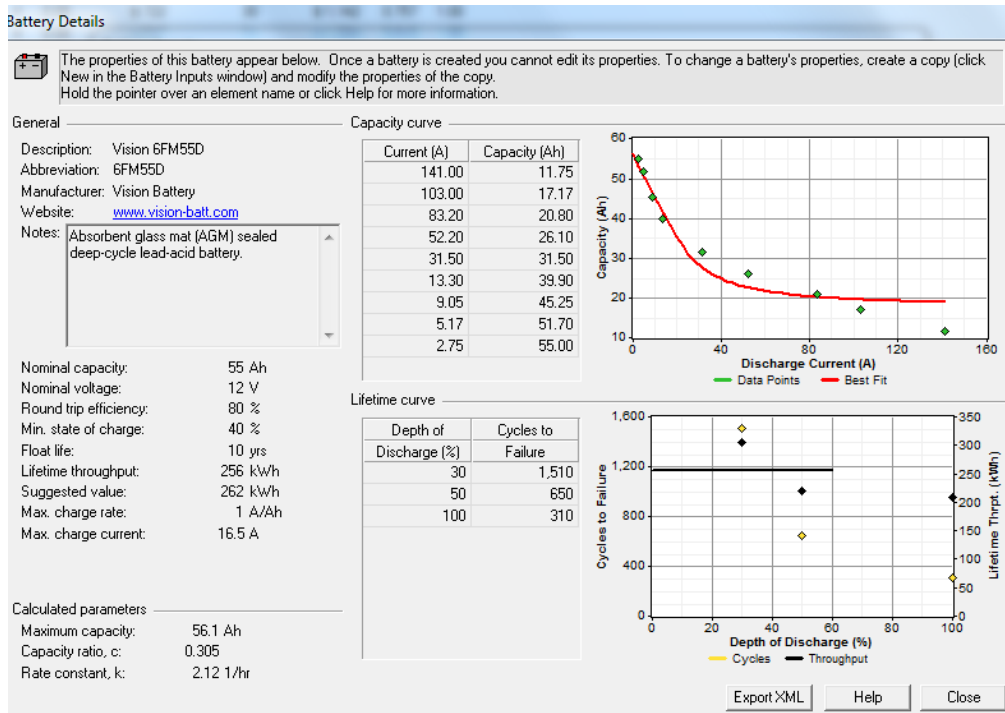

Figure 20. Battery Selection, Specification, and Settings.

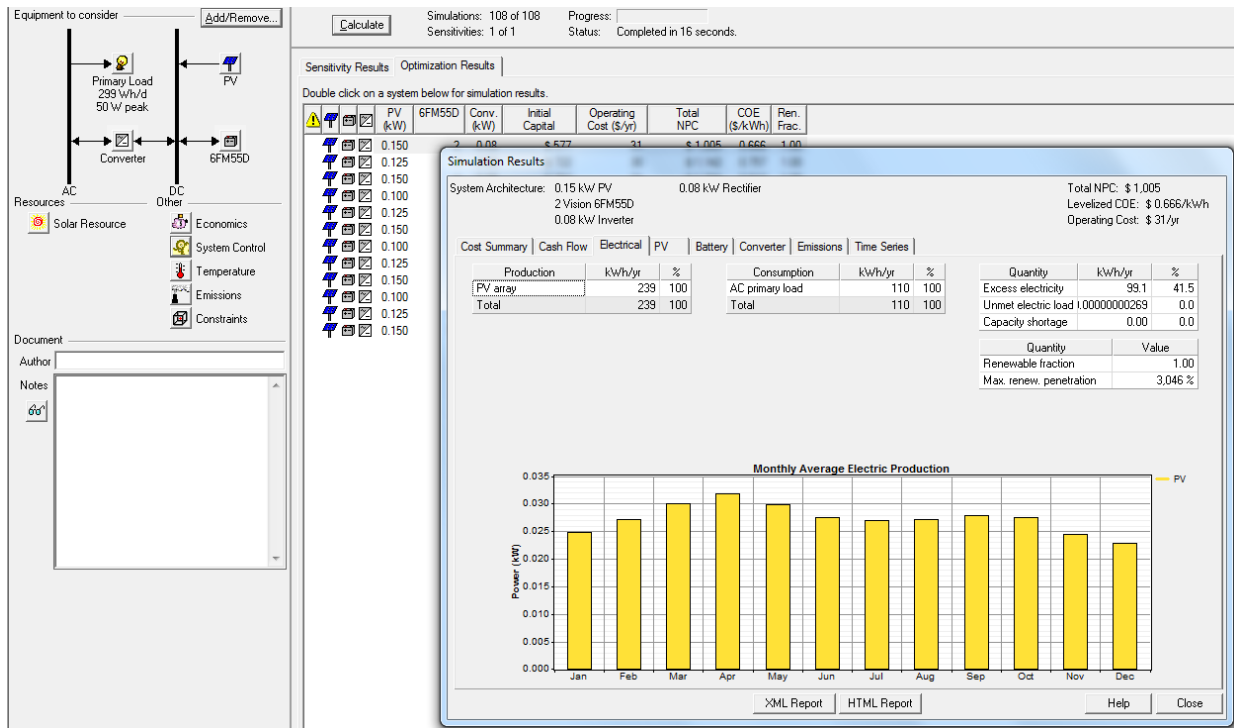

Figure 21. Optimization Results of 150 W Panel with 2 55 Ah Batteries.

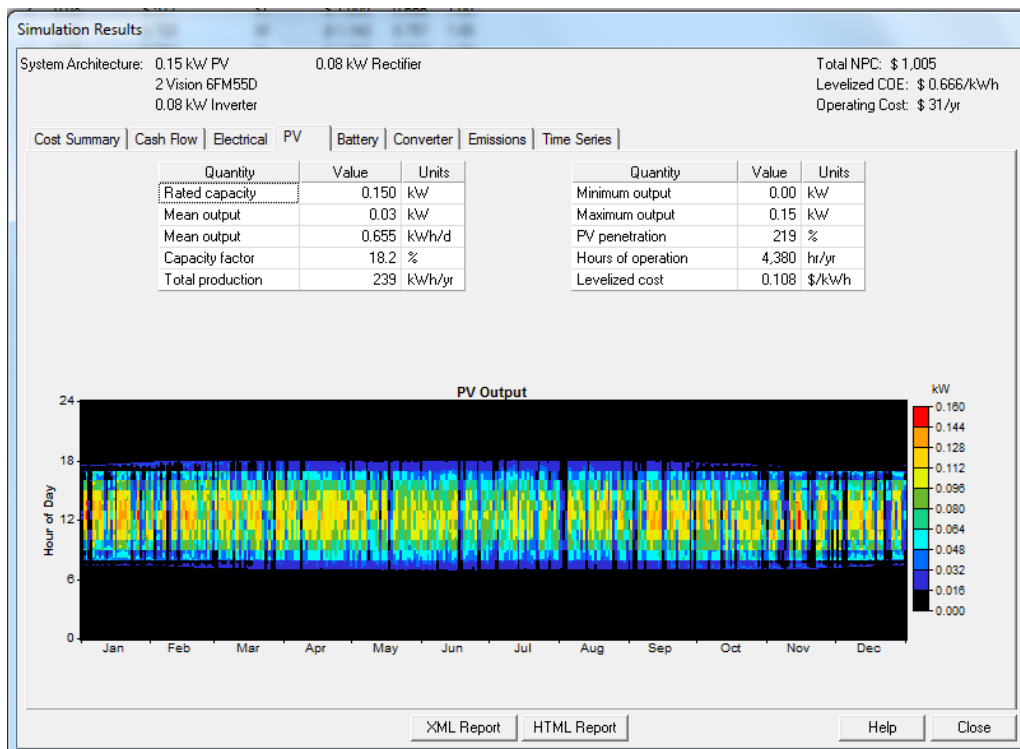

Figure 22. Photovoltaic Output Analysis over 1 year.

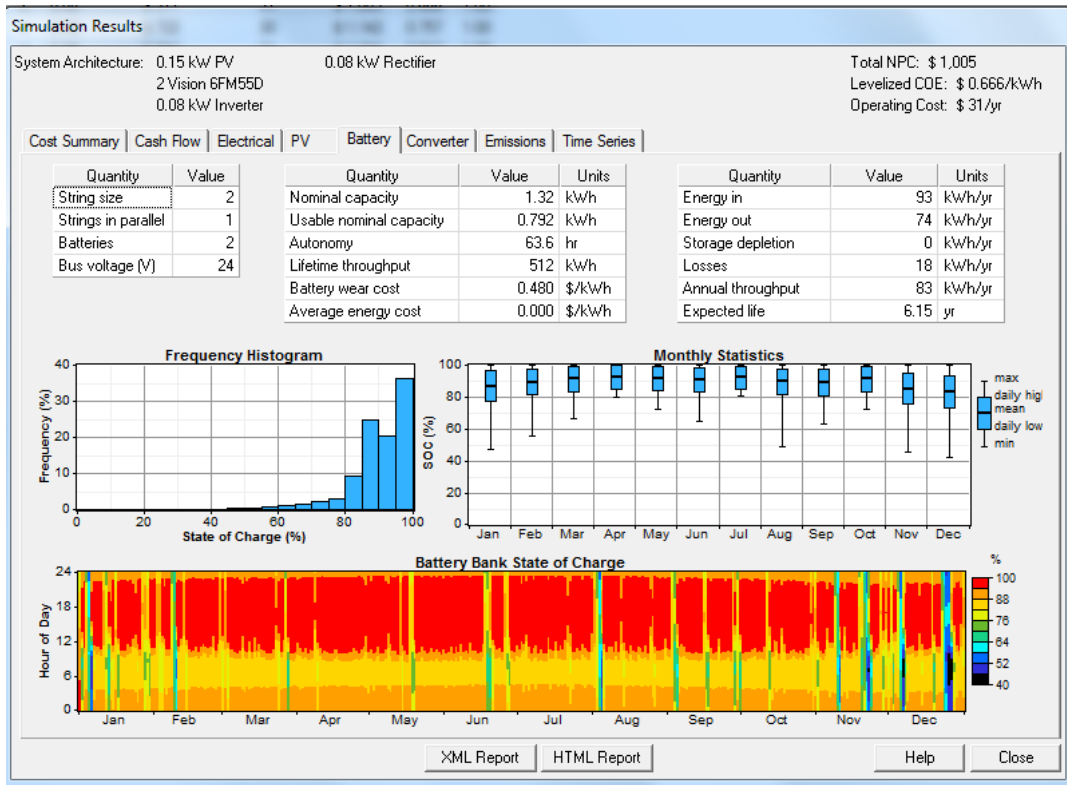

Figure 23. Battery Analysis: State of Charge Simulation over a year.

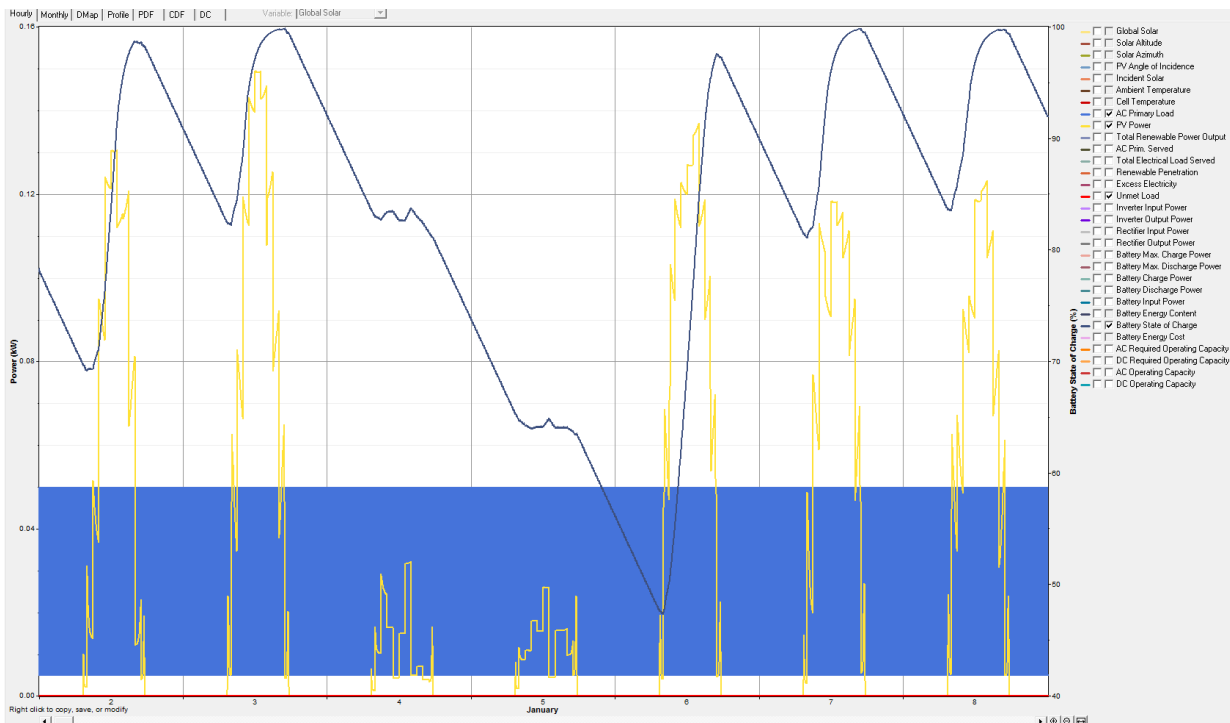

Figure 24. System Charge and Discharge Analysis over 7 days.

APPENDIX 3: FINAL SYSTEM ANALYSIS

WIND FORCE SIMULATION RESULTS							
COMPONENT	FRONT	BACK	TOP	BOTTOM	RIGHT	LEFT	NET FORCE
	<i>lbf</i>	<i>lbf</i>	<i>lbf</i>	<i>lbf</i>	<i>lbf</i>	<i>lbf</i>	<i>lbf</i>
Camera	28.44	12.00	0.05	0.04	0.02	0.03	40.57
Pan-Tilt	19.80	7.90	0.03	0.02	0.04	0.03	27.81
Enclosure	55.76	20.55	0.10	0.11	0.10	0.09	76.71
Solar Panel	84.04	112.62	12.95	15.55	0.03	0.03	225.22

WEIGHT MOMENTS ON POLE		
Pan-Tilt Mount:	25.3	lbf
Pan-Tilt x-dist:	-19	in
Pan-Tilt Moment:	-480.7	lbf*in
Solar Mount:	28.5	lbf
Solar x-dist:	7	in
Solar Moment:	199.5	lbf*in
Enclosure Mount:	81.15	lbf
Enclosure x-dist:	7	in
Enclosure Moment:	568.05	lbf*in
NET Moment	286.9	lbf*in

WIND MOMENTS ON POLE		
Pan-Tilt Mount:	68.39	lbf
Pan-Tilt Y-dist:	40	in
Pan-Tilt Moment:	2735.6	lbf*in
Solar Mount:	76.71	lbf
Solar Y-dist:	65	in
Solar Moment:	4986.2	lbf*in
Enclosure Mount:	225.22	lbf
Enclosure Y-dist:	16	in
Enclosure Moment:	3603.52	lbf*in
NET Moment	11325.27	lbf*in

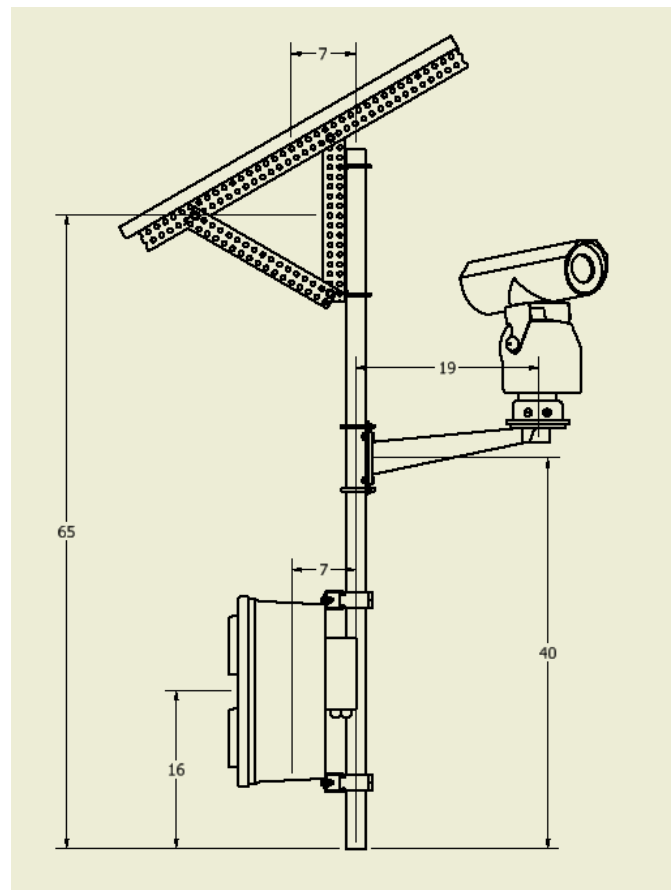

CAP SCREW SAFETY FACTOR & SIM		
UTS:	70,000	lbf/in ²
Minor OD:	0.24	in
Area:	0.046	in ²
shear_SIM:	5115	lbf/in ²
shear_UTS:	42000	lbf/in ²
Safety Factor N:	8.2	

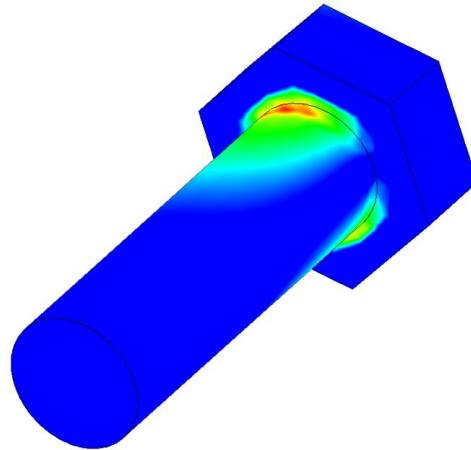

U-BOLT SAFETY FACTOR & SIM		
UTS:	70,000	lbf/in ²
OD:	0.313	in
Area:	0.076	in ²
shear_SIM:	41350	lbf/in ²
shear_UTS:	42000	lbf/in ²
N:	1	

ENCLOSURE U-BOLT TENSION		
Static Friction:	0.5	
Weight:	90	lbf
Units:	2	
sim_weight:	45	lbf
Min_4_Tension:	45	lbf

PAN-TILT U-BOLT TENSION		
Static Friction:	0.5	
Weight:	25.3	lbf
Units:	2	
sim_weight:	12.65	lbf
Min_4_Tension:	12.65	lbf

SOLAR U-BOLT TENSION		
Static Friction	0.5	
Weight:	28.5	lbf
Units:	2	
sim_weight:	14.25	lbf
Min_4_Tension:	14.25	lbf

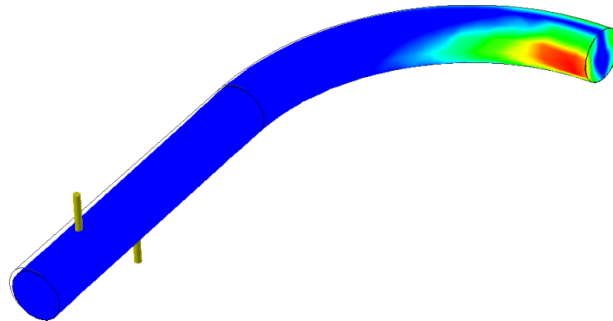

APPENDIX 4: PROPOSED LOCATIONS

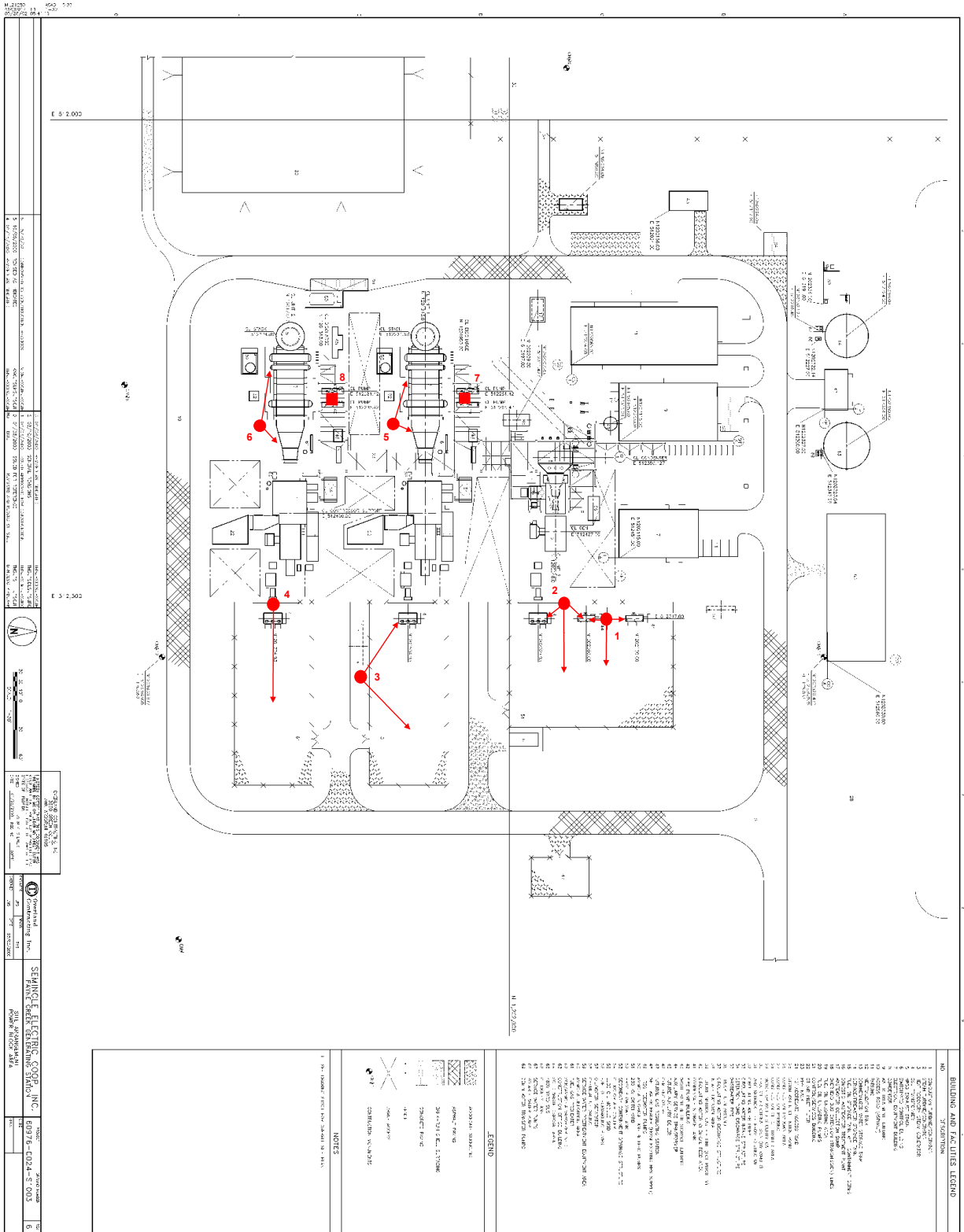

APPENDIX 5: BILL OF MATERIALS

Design Cost				
Component	Selection	Vendor (Part)	Quantity	Cost
Infrared Camera	FLIR A310F 25deg	Spectrom Group (61201-1103)	1	\$10,115.61
Pan Tilt	Axis Communications YP-3040	Surveillance Video (Axis 5502-461)	1	\$446.43
AC Adapter	Axis PS24 Adapter	Surveillance Video (Axis 5000-001)	1	\$135.43
Pan Tilt Arm	Axis Communications	Surveillance Video (Axis 5502-471)	1	\$43.92
Microcomputer	Versalogic VL-EPM-24SU	DigiKey (1241-1006-ND)	1	\$891.00
Breakout Paddleboard	Versalogic VL-CBR-5012	DigiKey (1241-1081-ND)	1	\$66.00
ATX Power Adapter	Versalogic VL-CBR-1008	DigiKey (1241-1041-ND)	1	\$33.00
LVDS to VGA Adapter	Versalogic VL-CBR-2014	Digikey (1241-1000-ND)	1	\$100.00
2.5" IDE DRIVE CABLE	Versalogic VL-CBR-4406	DigiKey (1241-1083-ND)	1	\$28.00
IDE Adapter Board	Versalogic VL-CBR-4405	DigiKey (1241-1084-ND)	1	\$34.00
20" 24-BIT LVDS CABLE	Versalogic VL-CBR-2012	DigiKey (1241-1001-ND)	1	\$41.00
Solar Panel	Renogy 150W 12V Mono	Renogy-150D	1	\$219.99
Solar Panel Cables	Renogy 16 ft 12 AWG Cables	Renogy (TRAYCB016FT-12	1	\$22.99
Solar Cable Adaptor Kit	Renogy 10 ft Cable Adaptor	Renogy (AK-10FT-12)	1	\$20.99
Charge Controller	20 A MPPT	EcoWorthy (MPPT20-1)	1	\$102.00
Battery	AJC 100Ah 12V AGM Battery	Battery Clerk (AJC-D100S-J-0-140935)	1	\$179.00
Inverter	Samlex America 150W	Inverter Supply (SA-150-112)	1	\$148.47
Wireless Adapter	A6100 Netgear Wi-Fi adapter	Walmart (551928248)	1	\$36.40
POE Splitter	POE Splitter, 1 Port	Primus Cable(NT1-3195-R)	1	\$23.19
Memory Module	2GB, Standard Temp	not purchased	1	\$35.00
ATX Power Supply	200W	Enlight (HPC-300-101)	1	\$32.99
IDE Hardrive	CD RW / DVD ROM	not purchased	1	\$60.00
Serial Communication Cable	RS 232 9 pin	not purchased	1	\$45.90
Mains Power Cable	120VAC 16 AWG Cable	not purchased	1	\$7.99
Pole	Low Carbon Steel, 6 Ft, 2in OD	McMaster (7767T57)	1	\$108.86
Weather Enclosure	Electronics Enclosure	LCOM (NB181608-00V)	1	\$240.25
Strut Channel	120 in, Zn PLATED	McMaster (3310T212)	1	\$34.68
Strut Channel Pipe Clamp	2 in OD, Zinc Plated	McMaster (3115T19)	2	\$2.04
Ubolt	2 in OD Pole U Bolt	McMaster (8896T129-A)	4	\$4.64
Pan Tilt Mounting Bracket	Machined	Custom	1	\$50.00
Solar Panel Mount	Solar Panel Mounting	McMaster (Solar-1)	1	\$100.69
90 Deg Track	72 in, Zn Plated	McMaster(8968K27-17.5in)	3	\$20.43
Cap Screw	5/16-18 in, 316 S.Steel, 10 pk	McMaster (93190A583)	3	\$4.56
Hex Nut	5/16-18 Zn-Al Coated Steel, 100 pk	McMaster (93827A219)	1	\$9.74
Washers	.375in ID, .875in OD, Steel, 100pk	McMaster (90108A415)	1	\$4.67
Total				\$13,392.22

Remaining Budget	\$6,607.78
-------------------------	-------------------

Prototype Cost			
Component	Selection	Vendor (Part)	Cost
Infrared Camera	FLIR A655sc	Dr. Oates	\$-
Pan Tilt	Axis Communications YP-3040	Surveillance Video (Axis 5502-461)	\$446.43
AC Adapter	Axis PS24 Adapter	Surveillance Video (Axis 5000-001)	\$135.43
Pan Tilt Arm	Axis Communications	Surveillance Video (Axis 5502-471)	\$43.92
Microcomputer	Versallogic VL-EPM-24SU	DigiKey (1241-1006-ND)	\$891.00
Breakout Paddleboard	Versallogic VL-CBR-5012	DigiKey (1241-1081-ND)	\$66.00
ATX-EPM Power Adapter	Versallogic VL-CBR-1008	DigiKey (1241-1041-ND)	\$33.00
LVDS to VGA Adapter	Versallogic VL-CBR-2014	Digikey (1241-1000-ND)	\$100.00
2.5" IDE Drive Cable	Versallogic VL-CBR-4406	DigiKey (1241-1083-ND)	\$28.00
IDE Adapter Board	Versallogic VL-CBR-4405	DigiKey (1241-1084-ND)	\$34.00
24-BIT LVDS Cable	Versallogic VL-CBR-2012	DigiKey (1241-1001-ND)	\$41.00
Solar Panel	Renogy 150W 12V Monocrystalline	Renogy-150D	\$219.99
Solar Panel Cables	Renogy 16 ft 12 AWG Solar Cables	Renogy (TRAYCB016FT-12	\$22.99
Solar Cable Adaptor	Renogy 10 ft Cable Adaptor	Renogy (AK-10FT-12)	\$20.99
Energy Analyzer	Renogy 150A High Precision Analyzer	Renogy (TrcrMtr-MT-150)	\$38.99
Wireless Adapter	A6100 Netgear Wi-Fi adapter	Walmart (551928248)	\$36.40
Charge Controller	20 A MPPT	EcoWorthy (MPPT20-1)	\$102.00
Battery	AJC 100Ah 12V AGM Battery	Battery Clerk	\$179.00
Inverter	Samlex America 150W	Inverter Supply (SA-150-112)	\$148.47
Mains Power Cable	120VAC 16 AWG Cable	Home Depot	\$7.99
Shipping			\$34.85
Prototype Total			2,630.45
Remaining Budget			\$369.55

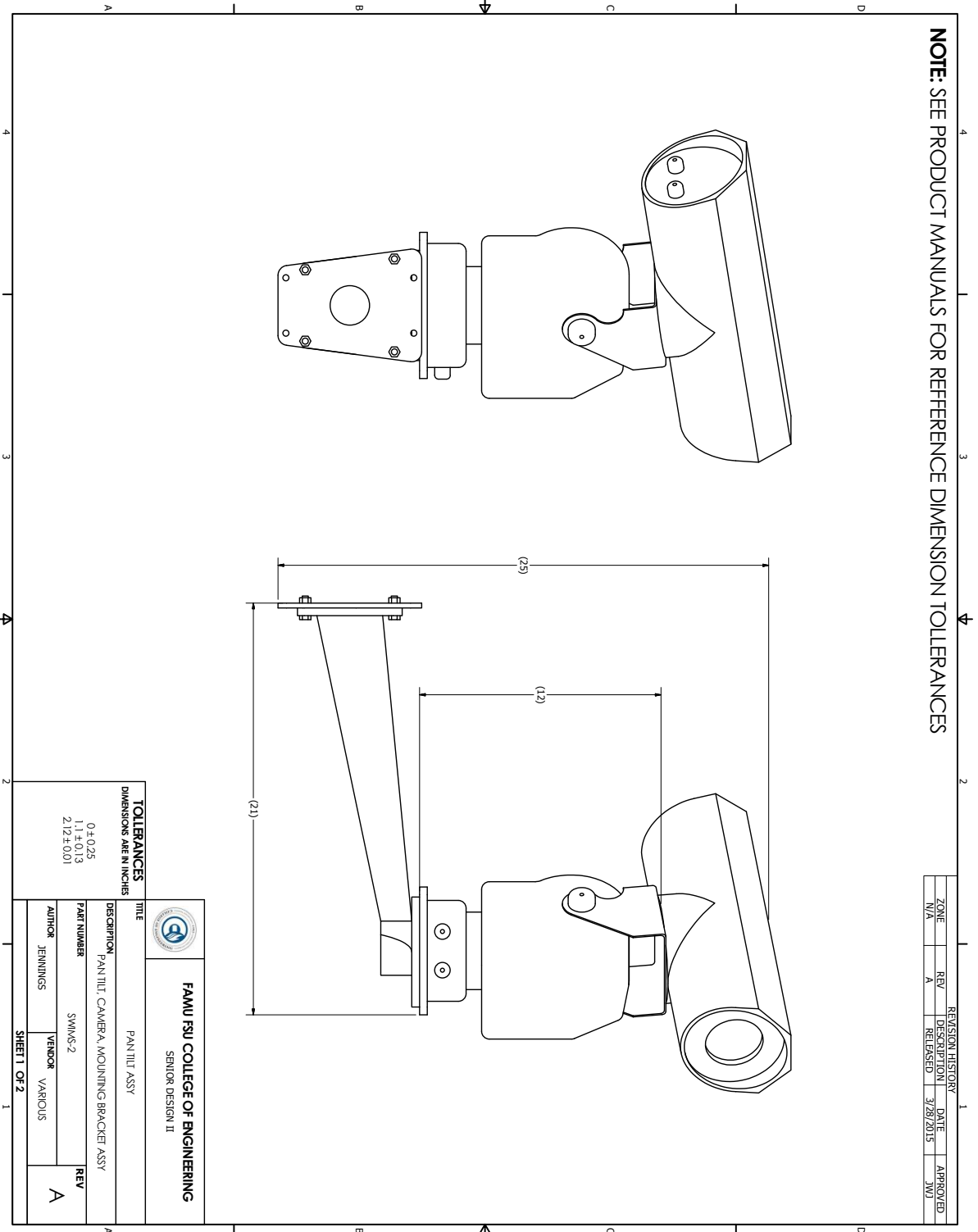

NOTE: FOR MANUFACTURING QUOTATION PURPOSES ONLY

ITEM	TITLE	PART NUMBER	DESCRIPTION	VENDOR	ESTIMATED COST	QTY
1	STEEL PLATE		PLATE, HOT ROLLED STEEL, A36, 12X12	ONLINEMETALS.COM	\$24.91	1

PARTS LIST

TOLERANCES	TITLE
0+0.025 1.1 ±0.13 2.12 ±0.01	FAMU FSU COLLEGE OF ENGINEERING SENIOR DESIGN II
TOLERANCES	PAN TILT MOUNTING BRACKET
DIMENSIONS ARE IN INCHES	DESCRIPTION PAN TILT MOUNTING BRACKET, MACHINED
	PART NUMBER PAN-TILT-1
	AUTHOR JENNINGS
	VENDOR CUSTOM
	REV A

SHEET 2 OF 2

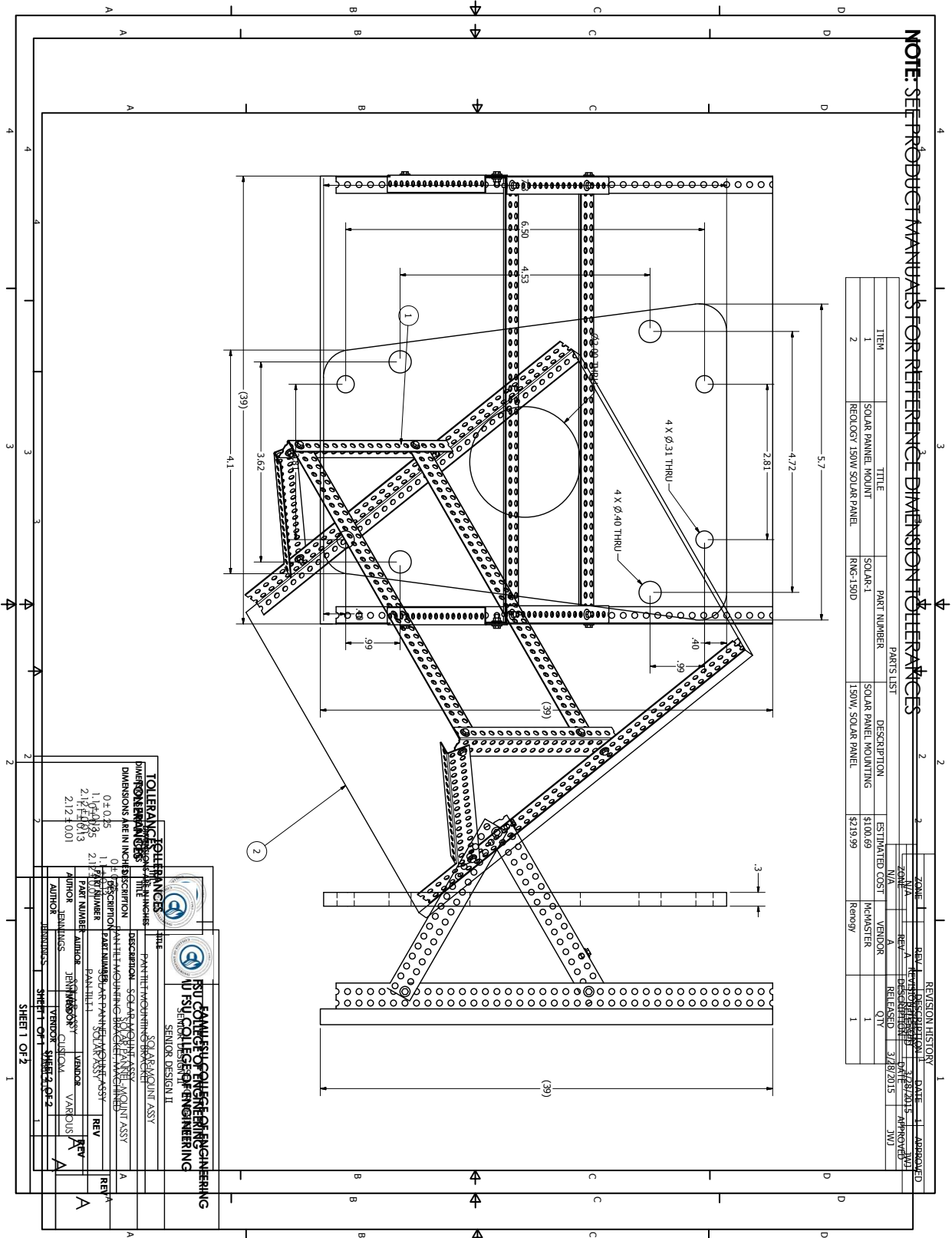

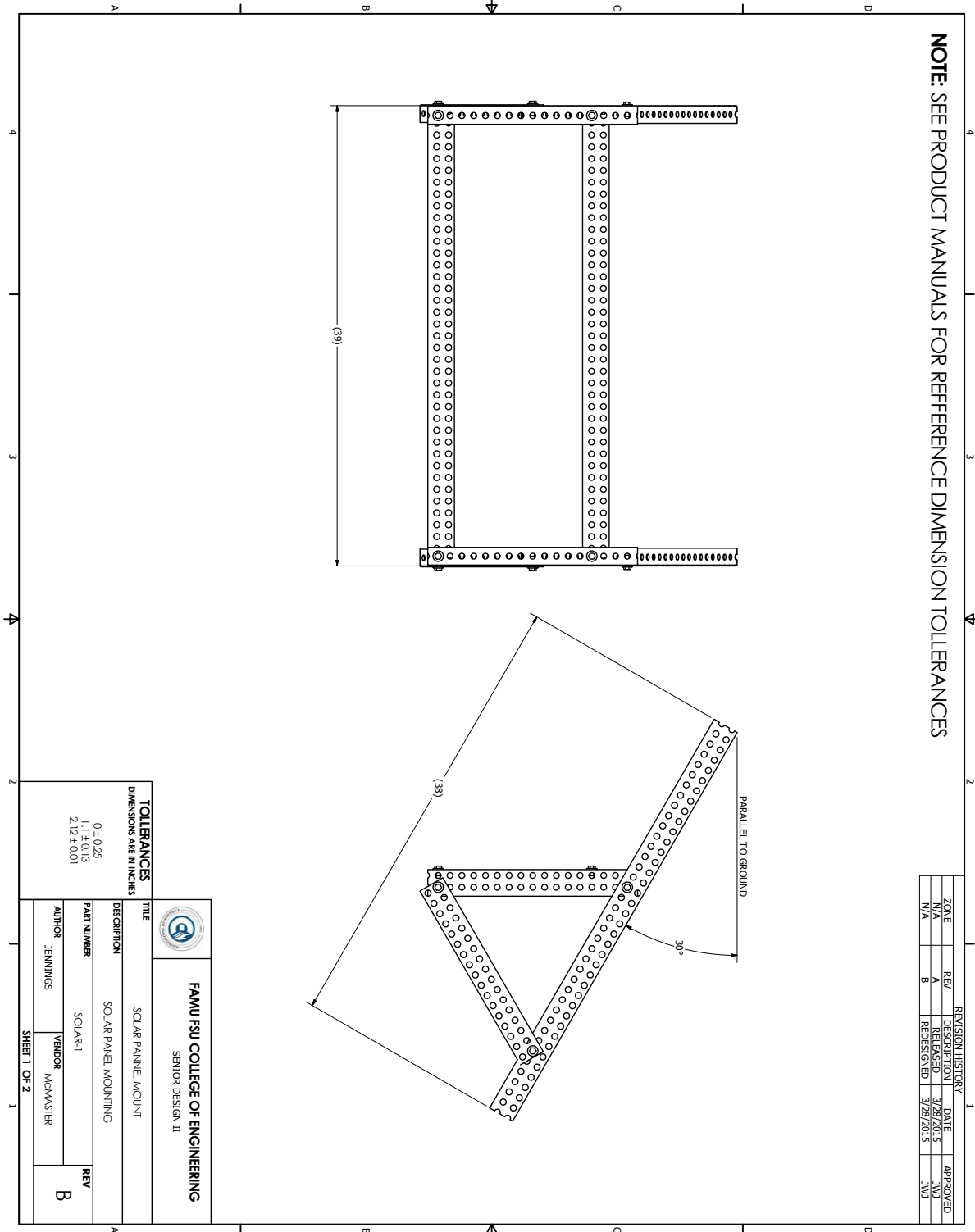

NOTE: SEE PRODUCT MANUALS FOR REFERENCE DIMENSION TOLERANCES

REVISION HISTORY		DATE	APPROVED
NOV	RELEASED	3/28/2015	JWJ
N/A	REDESIGNED	3/28/2015	JWJ

FAMU FSU COLLEGE OF ENGINEERING
 SENIOR DESIGN II

TOLERANCES		TITLE	
DIMENSIONS ARE IN INCHES		SOLAR PANNEL MOUNT	
0+0.25		DESCRIPTION	
1.1 ±0.13		SOLAR PANEL MOUNTING	
2.12 ±0.01		PART NUMBER	
		SOLAR-1	
AUTHOR		REV	
JENNINGS		B	
VANDOR			
MCMMASTER			

SHEET 1 OF 2

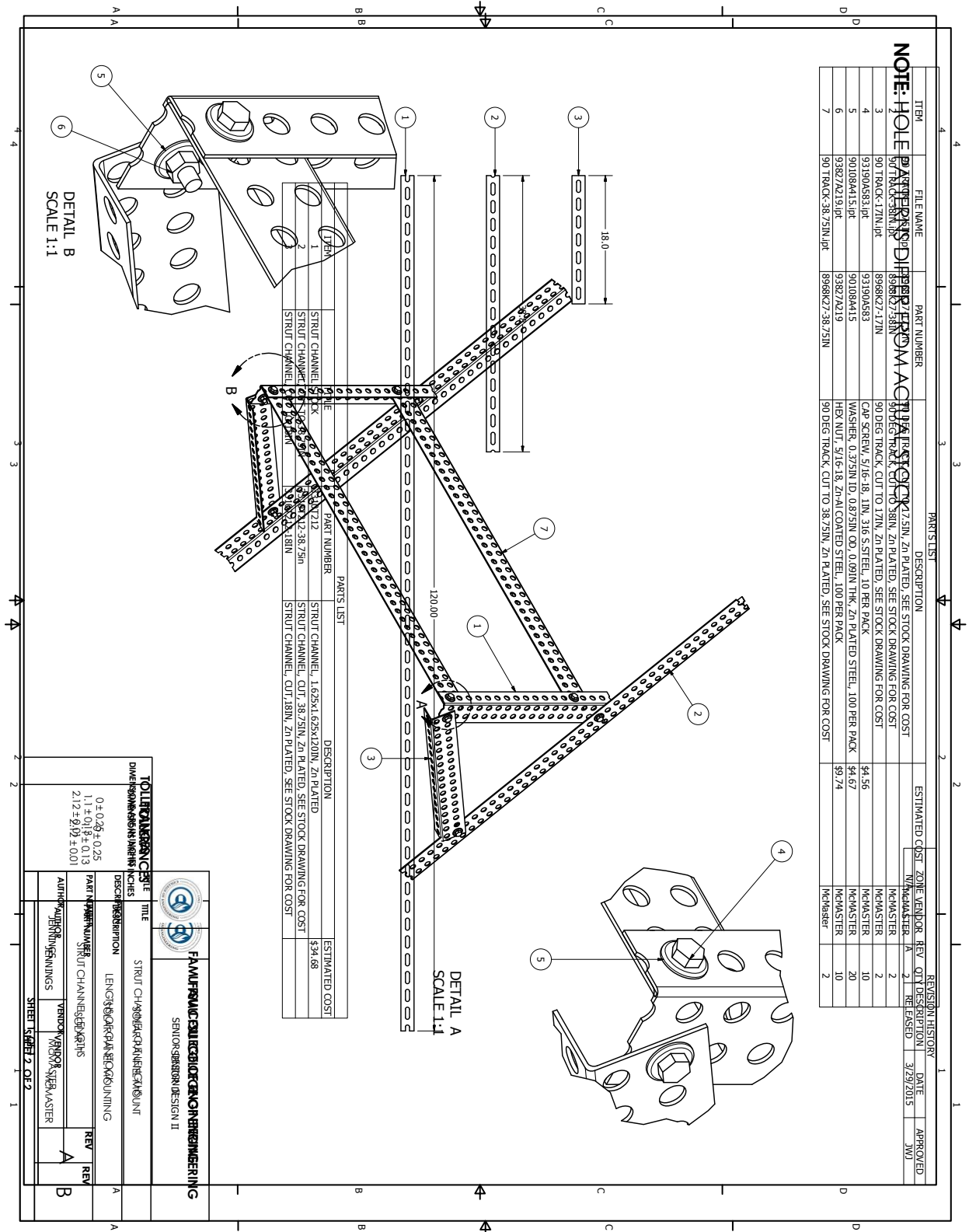

NOTE: HOLE

ITEM	FILE NAME	PART NUMBER	DESCRIPTION	ESTIMATED COST	ZONE	VENDOR	REV	QTY	DESCRIPTION	DATE	APPROVED
1	90 TRACK-17IN.IPT	8998R27-17IN	90 DEG TRACK, CUT TO 17IN, ZN PLATED. SEE STOCK DRAWING FOR COST		1	McMASTER	A	2	RELEASED	3/29/2015	JWJ
2	90 TRACK-17IN.IPT	8998R27-17IN	90 DEG TRACK, CUT TO 17IN, ZN PLATED. SEE STOCK DRAWING FOR COST		1	McMASTER	A	2	RELEASED	3/29/2015	JWJ
3	93190A583	93190A583	CAP SCREW, 5/16-18, 1IN, 316 S.STEEL, 10 PER PACK	\$4.56		McMASTER		2			
4	90108A415	90108A415	WASHER, 0.375IN ID, 0.832IN OD, 0.093IN THK, ZN PLATED STEEL, 100 PER PACK	\$4.67		McMASTER		10			
5	90108A415	90108A415	WASHER, 0.375IN ID, 0.832IN OD, 0.093IN THK, ZN PLATED STEEL, 100 PER PACK	\$4.67		McMASTER		20			
6	93827A219	93827A219	HEX NUT, 5/16-18, ZN-14 COATED STEEL, 100 PER PACK	\$9.74		McMASTER		10			
7	90 TRACK-38.75IN.IPT	8998R27-38.75IN	90 DEG TRACK, CUT TO 38.75IN, ZN PLATED. SEE STOCK DRAWING FOR COST		2	McMASTER		2			

ITEM	PART NUMBER	DESCRIPTION	ESTIMATED COST
1	STRUT CHANNEL	STRUT CHANNEL, 1.625X1.625X120IN, ZN PLATED	\$34.68
2	STRUT CHANNEL	STRUT CHANNEL, CUT, 38.75IN, ZN PLATED. SEE STOCK DRAWING FOR COST	
3	STRUT CHANNEL	STRUT CHANNEL, CUT, 18IN, ZN PLATED. SEE STOCK DRAWING FOR COST	

TOLERANCES DIMENSIONS IN INCHES 0 ± 0.25 ± 0.25 1.1 ± 0.11 ± 0.13 2.12 ± 0.09 ± 0.01	
TITLE STRUT CHANNEL DRAWING	DATE 3/29/2015
DESCRIPTION LENGTH OF CHANNELS	AUTHOR JENNIFER WENNING
PART NUMBER STRUT CHANNELS	CHECKED JENNIFER WENNING
AUTHORITY JENNIFER WENNING	APPROVED JENNIFER WENNING

FAMU/FSU COLLEGE OF ENGINEERING
 SENIOR DESIGNER DESIGN II

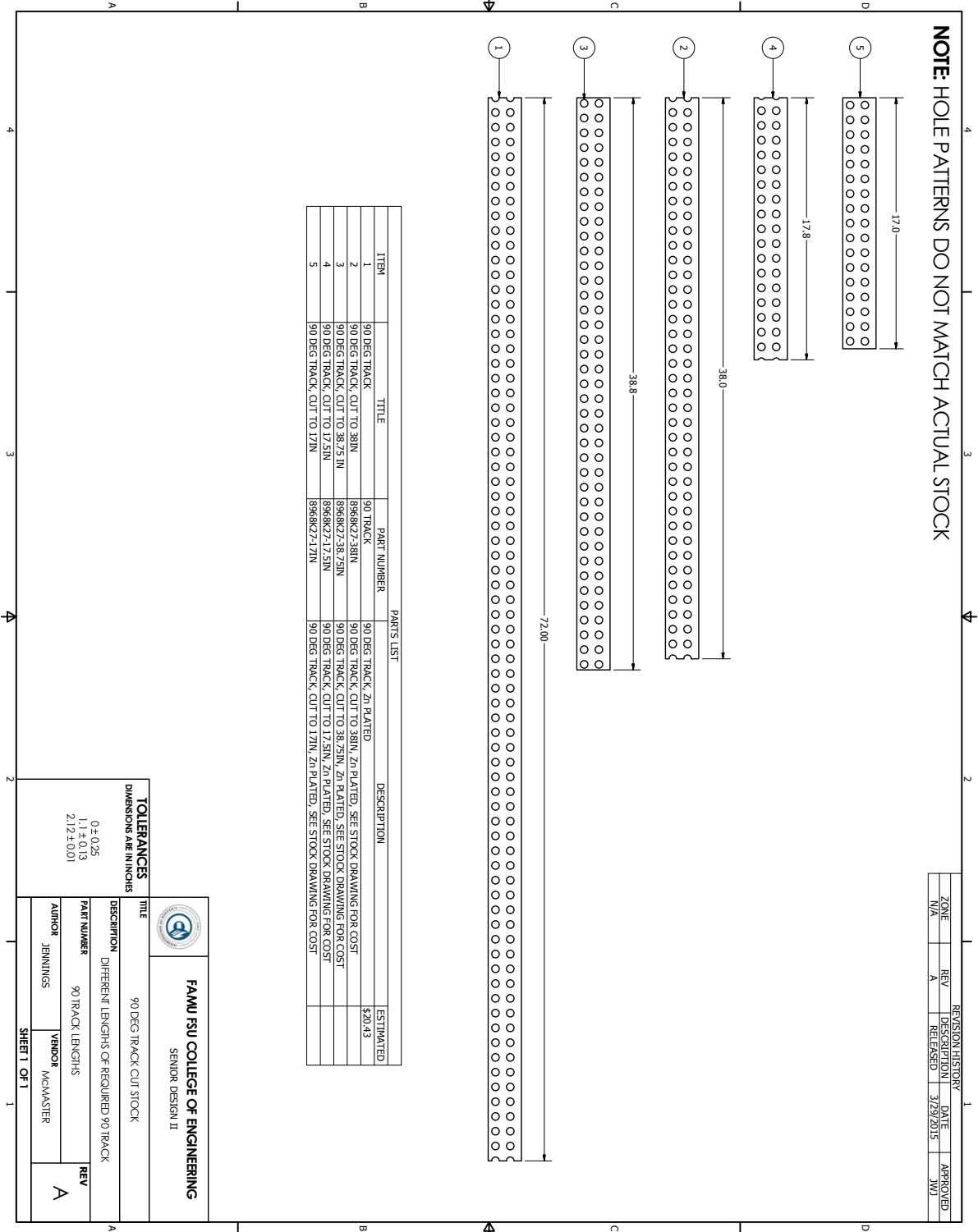

NOTE: HOLE PATTERNS DO NOT MATCH ACTUAL STOCK

REVISION HISTORY			
ZONE	REV	DESCRIPTION	DATE
N/A	A	RELEASED	3/29/2015
			APPROVED JWJ

ITEM	TITLE	PART NUMBER	DESCRIPTION	ESTIMATED
1	90 DEG TRACK	90 TRACK	90 DEG TRACK, Zn PLATED	\$20.43
2	90 DEG TRACK, CUT TO 38IN	8968KZ-38IN	90 DEG TRACK, CUT TO 38IN, Zn PLATED, SEE STOCK DRAWING FOR COST	
3	90 DEG TRACK, CUT TO 38.75 IN	8968KZ-38.75IN	90 DEG TRACK, CUT TO 38.75IN, Zn PLATED, SEE STOCK DRAWING FOR COST	
4	90 DEG TRACK, CUT TO 17.5IN	8968KZ-17.5IN	90 DEG TRACK, CUT TO 17.5IN, Zn PLATED, SEE STOCK DRAWING FOR COST	
5	90 DEG TRACK, CUT TO 17IN	8968KZ-17IN	90 DEG TRACK, CUT TO 17IN, Zn PLATED, SEE STOCK DRAWING FOR COST	

 <p>FAMU FSU COLLEGE OF ENGINEERING SENIOR DESIGN II</p>	
<p>TOLERANCES DIMENSIONS ARE IN INCHES</p> <p>0 ± 0.25 1.1 ± 0.13 2.12 ± 0.01</p>	
<p>DESCRIPTION DIFFERENT LENGTHS OF REQUIRED 90 TRACK</p>	
<p>TITLE 90 DEG TRACK CUT STOCK</p>	<p>REV A</p>
<p>PART NUMBER 90 TRACK LENGTHS</p>	<p>APPROVED JENNINGS</p>
<p>AUTHOR JENNINGS</p>	<p>VERBOR MCMAASTER</p>
<p>SHEET 1 OF 1</p>	

BIOGRAPHY

Michelle Hopkins - Project Manager

Michelle is a senior in Mechanical Engineering completing her final year as a Co-op with Siemens Energy. She specialized in, and is currently working on, Thermal Systems. She is currently a founding brother of the FSU Chapter of Theta Tau. Michelle plans to accept a full offer from Siemens Energy at the conclusion of the spring semester.

Nixon Lormand - Mechanical Engineering Lead

Nixon is a senior in Mechanical Engineering completing his final year. He specializes in mechatronics and robotics. Nixon is a member of ASME, NSBE, and Theta Tau and runs a blog about a robotics project he is a part of. He also does robotics research for Dr. Moore at the National High Magnetic Field Laboratory.

Kenny Becerra - Electrical Engineering Lead

Kenny is a senior and is double majoring in Computer and Electrical Engineering. He is an active member of SHPE and IEEE. He specializes in programming and embedded system software. Currently, he has an offer from PG&E as an IT Developer. He is interested in going back for his Masters in Computer Engineering after spending some time in industry.

Joseph Besler - Procurement Chair

Joseph is a senior in Mechanical Engineering and specialized in Dynamics. He is the secretary for SAE and interned for US Patent and Trademark Office. Joseph hopes to begin his engineering career in spring by getting a full time offer.

Alexander Hull- Programming Chair

Alex is a senior in Computer Engineering. He has interned at National Institute of Standards and Technology as well as worked under Dr. Edward Jones on programming an automated grading program. Alex plans on attending graduate school for Artificial Intelligence after finishing his undergraduate degree.

Jonathan Jennings - Prototype Chair

Jonathan is a senior in Mechanical Engineering and specializes in mechanical design/simulation. He is a founding brother and current President of the FSU Chapter of Theta Tau. He has previously interned at the National High Magnetic Field Laboratory in their Research and Development Department. He would like to pursue a career in Automotive or Marine Design.