

Final Design Report

Team 13

Tabletop Torsion Machine



Members:

Brendan Keane – bmk10c

Logan McCall – lgm12b

Reginald Scott – rbs09

Mark Swain – mas10h

Faculty Advisor:

Dr. Simone Hruda

Sponsor:

Mr. Philip Flater

Air Force Research Laboratory

Instructor:

Dr. Gupta

4/10/2015

Table of Contents

Table of Figures	iv
Table of Tables	v
ABSTRACT	vi
ACKNOWLEDGMENTS	vii
1. Introduction	1
2. Background and Literature Review	3
3. Concept Generation	6
3.1 Load Generation.....	6
3.2 Load Application.....	7
3.3 Load Measurement.....	8
3.4 Framing	9
3.5 Linear Motion.....	9
3.6 CAD Concept Evolution	10
4. Final Design	11
4.1 Final Design Overview.....	11
4.2 Design for Manufacturing	13
4.3 Design for Reliability	17
4.4 Design for Economics	19
4.5 Operation Manual.....	21
4.5.1 Functional Analysis	21
4.5.2 Product Specification	22
4.5.3 Assembly.....	23

4.5.4	Operation Instruction	24
4.5.5	Troubleshooting	25
4.5.6	Regular Maintenance	26
4.5.7	Spare parts.....	27
5.	Prototype Testing.....	28
6.	Considerations for Environment, Safety, and Ethics	29
7.	Project Management.....	30
7.1	Schedule	30
7.2	Resources	30
7.3	Procurement	31
7.4	Communication	32
8.	Conclusion	33
11.1	Future Recommendations	33
	References.....	34
	Appendix A.....	35
	Appendix B.....	37
	Appendix C.....	38
	Biography.....	39

Table of Figures

Figure 1: Example of a shear stress vs. shear strain plot for a sample undergoing a torsion test...	4
Figure 2: Evolution of CAD designs ending with final design.....	10
Figure 3: Final CAD assembly	11
Figure 4: Labeled CAD Assembly.....	12
Figure 5: Exploded view of final assembly	15
Figure 6: FEA Analysis performed on a support bar	18
Figure 7: Breakdown of budget by category.....	19
Figure 8: Comparison of similar torsion machines on market.....	20
Figure 9: Function analysis of torsion machine	21
Figure 10: CAD rendering of torsion machine with dimensions.....	22
Figure 11: Motor baseplate information	23
Figure 12: Free end assembly	24
Figure 13: Result of first prototype test	28

Table of Tables

Table 1: Specimen geometry	1
Table 2: Decision Matrix: Load Generation Component	7
Table 3: Decision Matrix: Load Application Component	8
Table 4: Decision Matrix: Linear Motion	10
Table 5: Bill of Materials	16

ABSTRACT

The Air Force Research Laboratory (AFRL) Munitions Directorate at Eglin Air Force base is always testing new materials for their products. These products range from a fighter jet frame to the warhead of a missile. These are very critical applications so they require the best lab equipment and highly accurate results. The current torsion tester at AFRL is very large and therefore inaccurate when testing small specimens. As a result, they have a need for smaller, tabletop torsion tester in order to get accurate data on the small specimens to use in their research. The new machine was fully designed and manufactured by the senior design team. The team used many design processes methods and consulted faculty members as well as tech support experts to come up with the final optimal design. The team broke the torsion machine into five major components including load generation, load application, load measurement, linear motion, and framing. Over the past two semesters, the team has successfully designed and built the machine according to the sponsor's requirements. The final machine consists of an AC gear motor, two 6-jaw chucks, a two rail ball bearing guide system, steel framing, and is compatible with the load measurement equipment at AFRL. The sponsor and team are both fully satisfied with the final product and believe the machine will prove to be successful at AFRL.

ACKNOWLEDGMENTS

Group 13 would like to thank the Air Force Research Laboratory at Eglin Air Force Base, and specifically their sponsor Phillip Flater for providing the team with the project. The group would also like to thank their faculty advisor, Dr. Simone Hruda, for her assistance throughout the production of the design.

The group would also like to thank the members of the FAMU-FSU College of Engineering Machine Shop for their great work on the fabrication of the parts necessary to complete the design. Finally, the team would like to thank the FAMU-FSU College of Engineering and Mechanical Engineering Department for providing the facilities that allowed for the completion of this design.

1. Introduction

Material testing is an essential part of designing new and improved products. It ensures reliability, efficiency, and safety. Knowing how a material acts under certain conditions allows engineers to create an optimal design. Without proper material testing an idea would never become reality. The Air Force Research Laboratory (AFRL) Munitions Directorate at Eglin AFB is currently testing materials to use with their products. These products range from warheads to the frame of a fighter jet. In order to ensure optimal performance and user safety, many material tests are performed. The current torsion machine at Eglin AFB is very large and is only effective when testing large specimens. They have a need for smaller, tabletop torsion testing machine. A smaller machine will lead to more accurate data when testing small specimens. These small specimens are used in order to test materials that are similar to the geometry of the product in the field. The dimensions of the specimen the AFRL is interested in testing are shown in table 1. The data that will be gathered from the new machine will more accurately characterize the materials and how they react under torsional loads. This will result in more accurate models and simulations used by the AFRL.

Table 1: Specimen geometry

Dimension	Measurement (mm)
Total Length	58.4
Gauge Length	12.7
Width	14.3
Inner Diameter	9.09
Fillet Radius	27.9
Hex Length	10.4

Working with the sponsor, the team has come up with the following problem statement to define the need for this project:

The current torsion tester at Eglin Air Force Base is very large and inaccurate while testing small specimens in free end torsion.

After the team and sponsor reviewed the background on the project and what its main objective is, the sponsor put some design requirements on the final design. The design requirements put on this project include:

- Maximum of 100Nm axial loading by the machine
- Budget - \$2,000
- Max surface area of machine – 2ft x 3ft (~1m²)
- Must do monotonic (one direction) free-end torsion loading
- Free end has one degree of freedom (axial direction due to contraction/expansion of specimen)
- Must be compatible with the DIC

From the above requirements, the team came up with some objectives that should be met by the conclusion of this project. The objectives are tasks the final prototype should be able to complete. These objectives include:

- Break aluminum specimen provided by sponsor
- Machine can be moved and operated by 1 person
- Machine is user friendly and safe

In general, there are 4 major components of a torsion machine. These components include load generation, load application, load measurement and housing or frame. Additionally, the Air Force sponsor has requested that the free end of the specimen has 1 degree of freedom in the axial direction. This will ensure accurate results even if the specimen expands or contracts during testing. After reviewing the constraints and objectives put on this project, the team conducted all of the necessary design analyses to come up with and build a final prototype. An AC gear motor and variable frequency drive (VFD) are being used in order to generate the load required to twist the specimen. The specimen will be held in place using two 6-jaw chucks. A strain rosette will be placed on the transmitting shaft in order to output the applied load on the specimen. Finally, the frame will be made out of steel and will utilize a 2 rail ball bearing guide in order to allow the free end to have 1 degree of freedom in the axial direction.

This report thoroughly goes through the entire design process the team has gone through to successfully complete this project. It fully justifies why each component was chosen and how it was eventually incorporated into the final assembly and work with the other components.

2. Background and Literature Review

The Munitions Directorate at Eglin Air Force Research Laboratory (AFRL) has tasked the team with designing and building a small scale torsion tester that can be used in their labs to help characterize different materials. The AFRL currently uses a torsion tester that is roughly three meters in length, to test samples that are no greater than eight centimeters long. Due to the large size of the machine in comparison to the samples being tested, the data collected from testing on the current apparatus is not ideal. Therefore, a smaller testing machine will be proved to the AFRL which will allow for more accurate results, while taking up much smaller space in the lab.

To further understand the task assigned to the group, the fundamentals of torsion testing will be discussed in detail. A torsion test measures the strength of a material against a twisting force. This is a very common test which is used to determine how a specimen of a specific material will interact when subjected to a torque. Through these laboratory tests, the behavior of these materials under specific loading conditions can be characterized, and although the geometries may change from test to real world application, important characteristics of the material can be determined which are independent of geometry.

In a typical torsion test, the specimen is gripped on both ends firmly so that no slippage may occur during the experiment. Then, once the specimen is secured, a motor and gear drive is used to apply a torque. One end of the specimen remains stationary during testing, while the other is rotated by the motor. The twist experienced by the specimen is recorded. By using the twisting information as well as the applied torque, many material properties can be determined.

The data collected from a torsion test can be represented in a shear stress vs. shear strain plot like the one shown in Figure 1. The shear stress applied to the specimen can be determined by using the equation

$$\tau = \frac{M_T r}{J} \quad (1)$$

where M_T is the torsional moment applied, r is the radius of the sample, and J is the polar moment of inertia. The shear strain applied can be calculated with

$$\gamma = \frac{r\theta}{L} \quad (2)$$

where θ is the angle of twist, and L is the length of the sample.

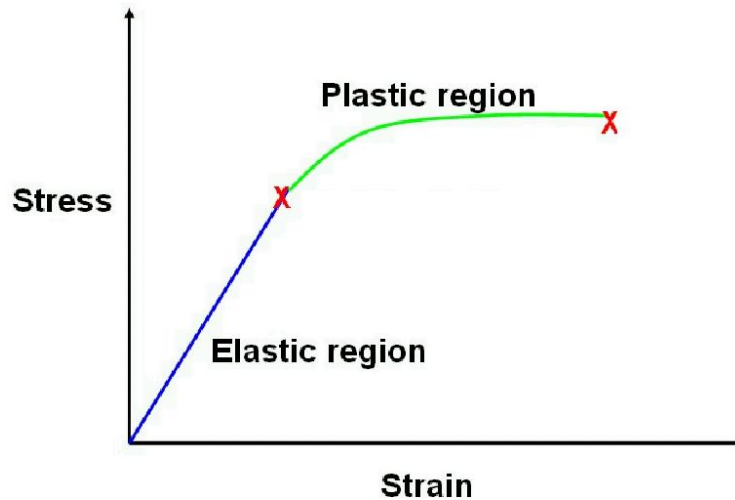

Figure 1: Example of a shear stress vs. shear strain plot for a sample undergoing a torsion test

In the elastic region of the plot, there is a linear relationship between the shear stress and shear strain experienced by the sample. This linear relationship leads to the determination of the shear modulus, G , of the material which can be determined using the equation

$$G = \frac{\tau}{\gamma} \quad (3)$$

When undergoing torsion, brittle and ductile materials will fail in different ways. A brittle specimen will break along surfaces 45° to the shaft axis. However, a ductile material fails along a plane of maximum shear, resulting in a fracture surface on a plane perpendicular to the shaft axis. [1]

Torsion testing machines have been around a very long time so the fundamental goal of this project is not new. What separates this project is the sponsor's special customization requests such as its low cost, small size, free end axial motion, and its ability to accurately test very small specimens. Tinius Olsen and Instron are two of the main companies that manufacture material testing equipment. These companies make great torsion testing machines for general applications but are very costly.

Although many material properties are already known from previous engineers performing tests and posting their results, the sponsor of this project benefits from performing these tests himself. Due to the nature of the products made for the Air Force, the tests performed at the AFRL are

unique and require new tests. Also, since the AFRL is interested in unconventional specimen geometries data is not known for much of their testing.

3. Concept Generation

The final design for the tabletop torsion tester is the final result of many previous designs. The design has greatly evolved from what the team first envisioned. The design process is very involved and requires a lot of analysis and brainstorming. It should be noted the machine was designed to break aluminum and titanium specimens as requested by the sponsor. The team initially separated the tabletop torsion machine into five major components, load generation, load application, load measurement, framing, and linear motion. This allowed for each component to be analyzed separately and lead to a final optimal design. Decision matrices were a very helpful tool in deciding what to use in the final design.

3.1 Load Generation

Load generation is a major component of the design. This section alone absorbed about 60% of our budget for the entire project. This component includes all parts involved in generating the load in order to break the specimen. For the tabletop torsion device, there were three main options that were discussed as possible ways to generate the load. These options were as follows: manual powered by a hand crank system, a hydraulic motor and controllers, and an AC motor and controller. These three options were compared and after a careful review of the benefits and limitations of each, the AC motor was determined to be optimal choice for this build. The decision matrix below in Table 2 was a major tool to assist in the decision making process after consulting with our advisor and sponsor. The main categories that were compared that we based our final design on were cost, overall accuracy, complexity, and variability. Both the hydraulic and the AC motor systems excelled fairly equally in reference to performance. The manual crank system was the most cost effective but would not be nearly as accurate or repeatable, which is one of the main criteria when doing any type of laboratory research. This tester must be able to reproduce results to ensure that the data collected is reliable. The AC motor and controller system became the ultimate choice due to its low complexity, ease of implementation, and low maintenance ratings. The type of controller that was chosen to go with this motor system is called a Variable Frequency Drive (VFD). The VFD is fairly easy to implement but also very expandable if the sponsor would like to use this system for further research.

Table 2: Decision Matrix: Load Generation Component

Design	Cost	Weight	Accuracy	Complexity	Maintenance	Variability	Total
Weight Factor	0.25	0.05	0.25	0.1	0.1	0.25	
Crank System	5	3	1	5	5	1	2.9
Hydraulic	1	1	5	1	1	5	3
AC Motor	3	3	5	3	3	5	4

3.2 Load Application

The load application component for the design includes all parts that are involved in transferring the load to the specimen. Four gripping mechanisms were examined for this torsion device. These mechanisms include a 3 tooth chuck, 4 tooth chuck, a vise grip, and a collet. It is important that a proper gripping mechanism is chosen in order to achieve the highest accuracy possibly. The grip must ensure that there is not any slip or off axis loading. For this design, the 3-tooth chuck was initially selected as the most effective method for gripping the samples. The main benefits of the 3-tooth chucks are that they are relatively inexpensive while still being able to hold a variety of different sample geometries and sizes. The 4 tooth chuck was not selected because it is unable to hold hexagonal specimens, and the machine should have that variability should the sponsor choose to test different geometries. The vise was not selected as the optimal choice for this design because it would weigh substantially more than any other of the potential components. The collet was deemed ineffective as well for this design a collet can only hold a very specific size of specimen. If the size of the specimen is every changed, then a new collet would need to be purchased. Therefore, because of the variability, cost-effectiveness, and ease of use provided by a 3-jaw chuck, it was deemed the optimal choice for load application. However, due to the sponsor need, a 6-jaw chuck was selected to hold the specimens. A 6-jaw chuck operates on the same principles of a 3-jaw chuck, but provides a greater surface area to hold the specimen which will go further to

ensure that the specimen does not experience any slippage during testing. The decision matrix that was used for Load Application is depicted below in Table 3.

Table 3: Decision Matrix: Load Application Component

Design	Cost	Weight	Reliability	Complexity	Variability	Total
Weight Factor	0.25	0.15	0.3	0.1	0.2	
3 Tooth Chuck	5	5	5	3	5	4.8
4 Tooth Chuck	3	5	5	3	1	3.5
Self-Aligning Vise	3	1	3	5	5	3.3

3.3 Load Measurement

The torsion tester will be used in conjunction with the Digital Image Correlation (DIC) that is provided by the sponsor in order to determine the strain present in the sample during testing. Using a high speed camera and measuring the particle displacement on the surface of the specimen, the strain experienced can be calculated. Therefore, it is only necessary for the design to determine the stress that the sample undergoes during testing. The load measurement component includes all parts that are involved in measuring this stress that is applied to the specimen. A strain rosette and torsional spring were compared for use in the final design. After consulting with our sponsor, the strain rosette was chosen to assist in the task of measuring the applied stress. This design includes placing a strain rosette on the coupler on the transmission shaft that connects the motor to the gripping mechanism used to hold the specimen. The coupler needed to be made out of a highly resilient material that will only undergo elastic deformation under the applied load. The material chosen for the coupler was Aluminum 6061. In the elastic region, a linear relationship exists between strain (γ) and stress (τ). The slope of this relationship represents the shear modulus (G). This allows a program to easily solve for the applied stress since the properties of the coupler are known. Additionally, strain rosettes are easy to replace and require very little installation time as long as someone has experience with soldering. Due to their geometry, the direction that a strain

rosette is placed is not important, making it very easy to implement in to a design. They are not very expensive and are highly accurate. The sponsor will be providing the strain rosettes as well as signal conditioning equipment from his facilities and all implementation of this equipment will occur after the device is delivered to Eglin AFRL.

3.4 Framing

After performing a material selection process for the construction of the housing, the material selected for this build was aluminum. However, after speaking with faculty and considering other factors in the fabrication of the housing, it was determined that steel was the optimal material for this design. Steel will provide an extra factor of safety that will allow for the torsion tester to withstand all potential forces and torques applied to the frame. Steel is also easier to machine and weld for the machinists that were consulted with in the shop, and although the steel is slightly more costly than aluminum, the added benefits of the safety factor and ease of fabrication are considered to be worth the extra cost. Extensive study was done on a single member of the frame to determine the maximum stress along the axial direction. Using our wall thickness in the steel member, it is capable to be drilled and tapped to receive the additional components of the machine. After research, the frame had a factor of safety way beyond the realm of failure for this application. The deformation seen during simulation was around 5 micrometers, which is an accepted value for the frame. The thickness of the frame is also important because the components need enough threads to grab and remain stationary. The frame needs to be as rigid as possible within reason to allow the most accurate reading during the test. The goal was ultimately met using the steel framing. Much of the FEA testing is shown in Appendix B.

3.5 Linear Motion

As discussed previously in the constraints, the free end of this torsion testing device must allow for 1 degree of freedom in the axial direction during testing. This is to permit the specimen to expand or contract while loading is applied to produce the most accurate results possible. For this design, three potential constructs were compared that utilized varied geometries and bearings. After performing a selection process using the matrix depicted below in Table 4, it was decided that a 2 rail ball bearing system will be used on the free end to allow for this motion. This platform will let the free end smoothly translate back and forth with minimal friction. This design was

selected over the other choices mainly because it was deemed the most inexpensive due to the use of ball bearings over linear roller bearings, and the least likely to fail under the applied load.

Table 4: Decision Matrix: Linear Motion

Design	Cost	Weight	Durability	Complexity	Total
Weight Factor	0.4	0.2	0.2	0.2	
4 Rail Ball Bearing	1	3	1	1	1.4
2 Track Roller Bearing	3	5	5	5	4.2
2 Rail Ball Bearing	5	5	3	3	4.2

3.6 CAD Concept Evolution

Figure 2 below shows all of the CAD assembly concepts the team has gone through to arrive at the final optimal design.

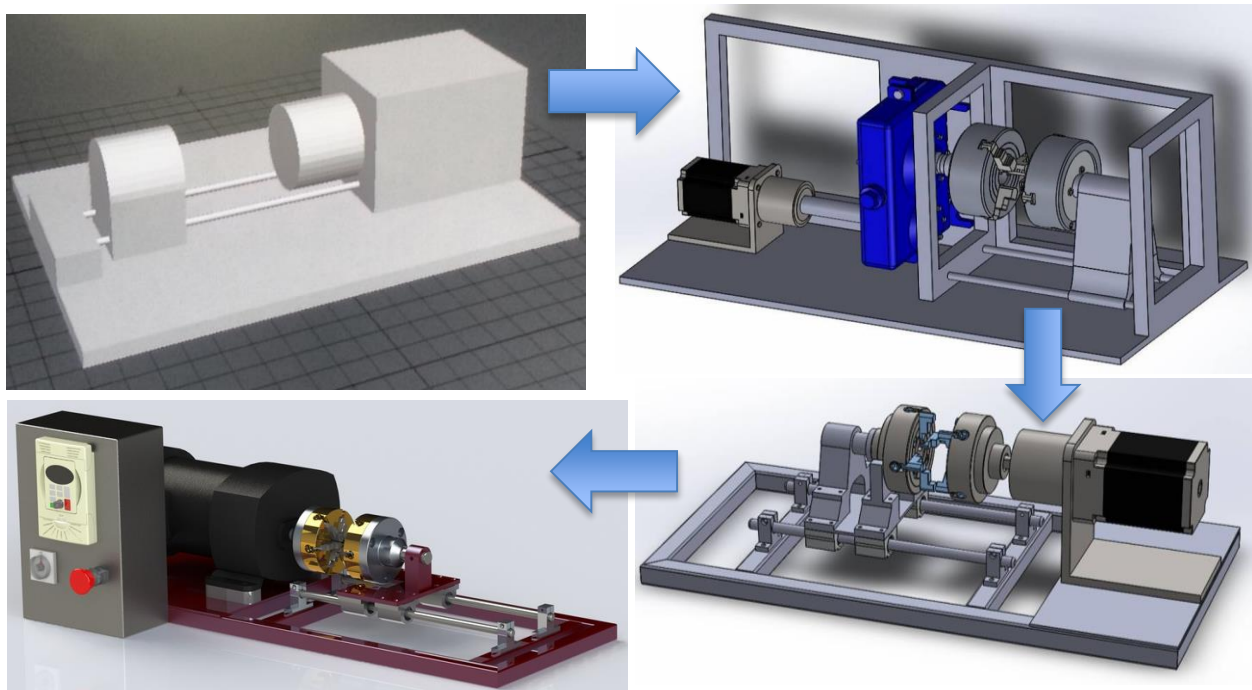

Figure 2: Evolution of CAD designs ending with final design

4. Final Design

4.1 Final Design Overview

After completely analyzing each component of the torsion machine, the team arrived at the final optimal design. As previously discussed, decision matrices for each component were used to ultimately choose the final components. The team also consulted their sponsor, advisor and tech support from vendors to help make the final decision on parts. Additionally, the team also conducted FEA on major components that would feel high stresses in order to justify the choices. The final CAD rendering of the tabletop torsion machine can be found in Figure 3.

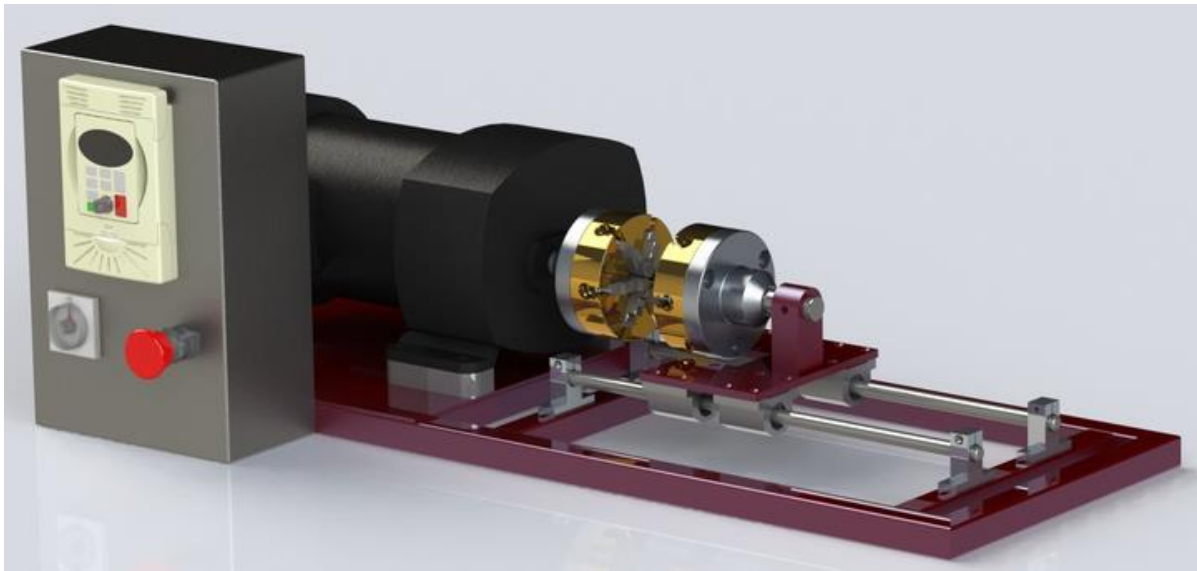

Figure 3: Final CAD assembly

A simpler CAD rendering of the final design can be found in Figure 4. This figure clearly labels all of the components used in the final design.

As shown in Figure 4, the motor is the largest part of the assembly and the most important. After conducting research on possible AC motors and talking to various tech supports, the team went with the AC Gearmotor from Grainger. This motor can generate up to 116Nm and has a built in spur gear set with a 95:1 ratio. The motor is rated for 1/3 horsepower at 18 rpm and weighs approximately 26 lbs. This motor has proven that it is more than capable of breaking the specimens and has the ability to do cyclic loading if needed. The calculations for the torque needed to break the specimens can be found in Appendix A. The team also decided to go with a variable frequency

drive (VFD) to control the motor. The VFD is from Automation Direct and is capable of controlling motor perfectly for this application. Due to its keypad, it is user friendly and allows for forward or reversible motion.

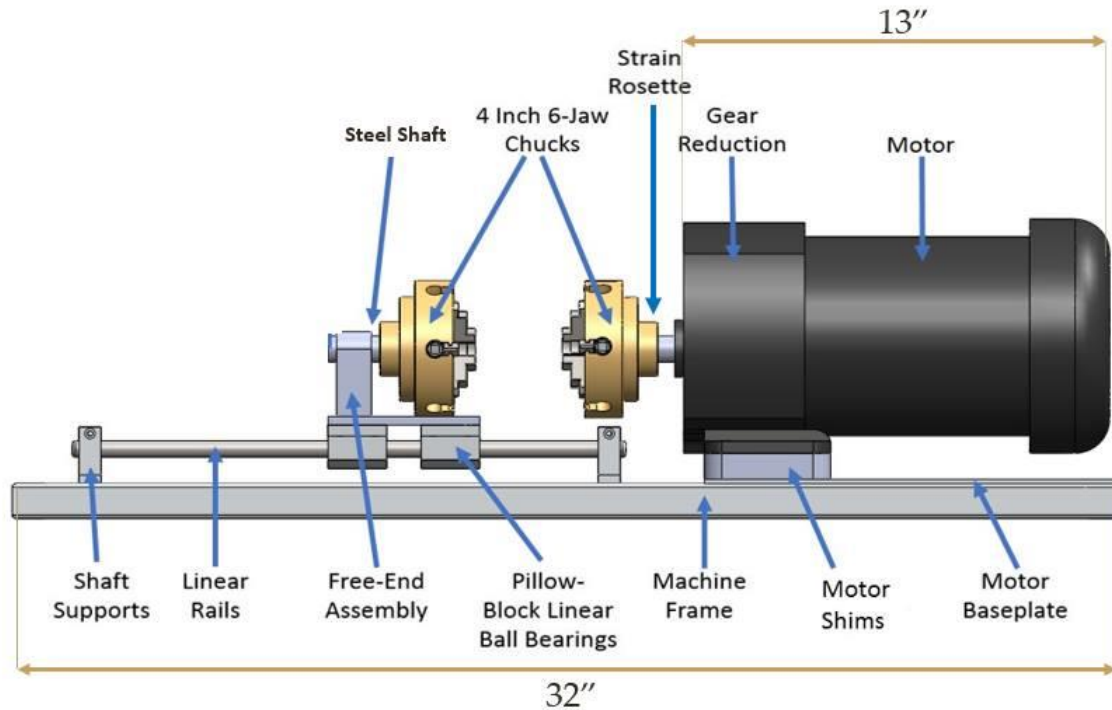

Figure 4: Labeled CAD Assembly

Next, the team decided to go with two 4 inch 6-jaw chucks in order to hold the specimens. These chucks were bought from LittleMachineShop and weigh about 6 lbs with 4 inch and 1 inch outer and inner diameters respectively. The team went with 6-jaw chucks due to greater load disbursement on the specimen grips and the ability to hold different grip shapes if needed.

For the linear motion requirement, the team went with a 2 rail ball bearing guide system. The system utilizes two $\frac{1}{2}$ inch stainless steel rails and 4 pillow blocks with bearings. All of the pieces needed for the system was purchased from Grainger. After stress analysis was done on the rails, it was found that the deflection of the rails under the worst condition would be under 0.001 inch which is acceptable for this application.

In order to hold all of the components in place, a proper frame had to be designed. After consulting the team advisor and other materials professors, the team decided to go with $\frac{1}{8}$ inch hollow square steel tubing for the frame from Grainger. The outer frame is low carbon 1015 steel and the inner supports are 304 stainless steel. Steel was chosen due to its high shear modulus which results in

high rigidity and no warping under testing conditions. The frame was analyzed under the highest stresses using FEA. An example of the FEA conducted can be found in Figure 6 which is discussed later on. Further FEA can be found in Appendix B.

The last part of the final design is the load measurement aspect. It should be noted that all load measurement equipment is at the AFRL and the sponsor only requested that our machine is compatible with the equipment. For specimen strain, the AFRL used a digital image correlation (DIC) system. This system uses two high speed cameras hooked up to a sophisticated computer program. Before testing, the specimen is speckled with black and white spray paint. Then, the cameras track the displacement of these specs during testing and use the computer program to measure the strain fields on the specimen. For load measurement, strain gages will be placed on the transmitting coupler as shown in Figure 4. Since the couplers are made out of aluminum 6061 and have custom dimensions they will only elastically deform. From the linear relationship of the shear modulus discussed earlier and knowing the properties of the coupler using equation 3, the applied stress can be solved for. The team will provide the sponsor with all the necessary information to take these data measurements.

4.2 Design for Manufacturing

The manufacturing and assembly aspect of this project is very involved. The frame, free end, and couplers had to be machined from raw stock material. This process took time and required accurate and clear engineering drawings from CAD. The other components of the machine such as the motor, VFD, chucks, pillow blocks, and linear rails were ordered from various vendors and took time to be delivered. Once all of the parts were completed in the machine shop and delivered assembly began.

First the group selected to machine the free-end due to it being such a critical part in the alignment of the machine. The baseplate was cut with clearance holes in the OMAX waterjet in the school's machine shop, followed by the free-end stand which was also cut in the waterjet. Upon press fitting these items with six tons of force it became time to mount the already purchased pillowblock bearings. It was decided in the shop to tap each of the holes in the pillow blocks, and use the baseplate as alignment. To aid in strength the baseplate was countersunk to make the series more rigid. Upon assembling the pillowblocks it was time to broach the free-end shaft to make way for

the key. With the free-end assembly complete, the already purchased precision rails, and support blocks were ran through the pillow blocks to complete that section of the machine.

The next major phase of machining consisted on the motor side of the machine. This assembly consisted of the 304 SS support tubes which ran through the entire frame. Cutting these down to size and milling in the various slots and clearance holes allowed the second major assembly to get started, while still continuing the first. Once these were cut the motor shims and motor baseplate were machined using a press drill, and a mill. Assembling these items along with the support bars completed the motor subassembly.

After both of the subassemblies were complete it was time to construct the frame. The remaining members were cut to size on the Do-all band saw in the school's machine shop. After the tubes were cut, they were cleaned and prepped for welding. Laying out the frame and subassemblies on the welding table it became important to insure everything remained straight. Considering the slots on the support bars it was deemed that having a precision bar locked into the assemblies would make the machine straight enough to tack together. Once the frame was tacked together, the machine was completely deconstructed in order for final welding. Upon completing the welding it was necessary to grind down each of the welds to make the frame flat. This need was due to the fact that it had to sit flat on the table, and have each assembly bolted to it. After grinding it was prepped for paint, which completed the machining, and assembling of the tabletop torsion machine.

The torsion machine assembly took more time than the team initially thought it would. This is partly due to the fact that some parts were ordered late and took a while to ship. Also, during the machining process some of the pieces had to be cut multiple times in order to ensure they were the desired size. Furthermore, the actual assembly and machining caused delays in the production of the build. The assembly took longer than expected due to our first machine being our only machine produced. This meant that when alignment issues arose, they had to be machined a second, or third time to keep the necessary alignment. Some noted issues throughout the machining process: the free-end stand stock was mounted incorrectly in the waterjet and skewed the final product. This meant that the stand had to be recut in the waterjet which took extra material, and extra time. The next major flaw in the machining was the dimensions on the pillowblocks did not exactly match the ones that were in the CAD assembly on the computer, so that part had to be recut as well. This

put major emphasis on the parts being ordered may not be exactly the specs they said they were when purchased. After those two instances the rest of the project went smoothly other than the machine shop being backed up. We still managed to plow through the project by working on site in the machine shop. Lastly the welding of the frame, and final machine assembly took an entire day, this was much longer than expected. Throughout the advising of the machine shop, the actual machining hours, and the assembling in the machine shop, the total time spent in the machine shop was accounted to be approximately 150 hours. When considering the idea of constructing a final product as a prototype, it can easily be seen how the addressed problems drastically extended the time to design, machine, and construct the torsion machine.

Figure 5 shows an exploded view of the assembly with dotted lines showing where each part goes. This figure shows the relative size of each part and gives a good representation of all of the parts required to build this tabletop torsion machine.

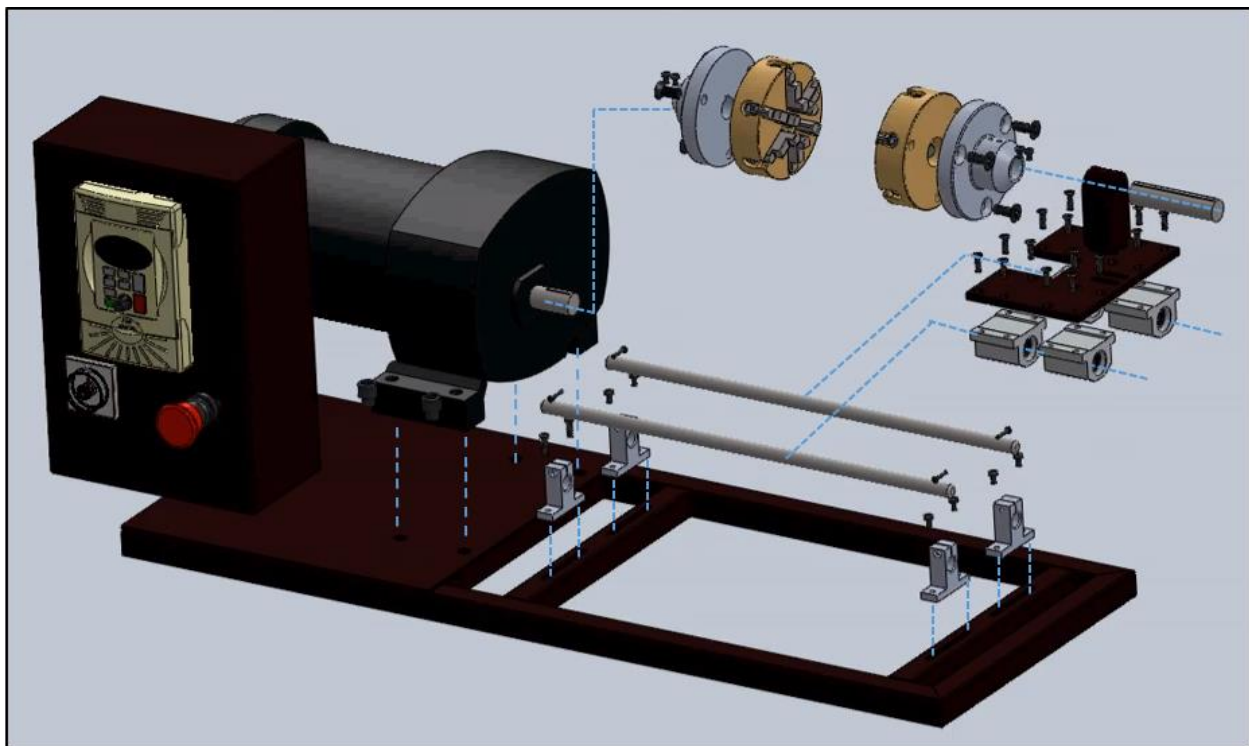

Figure 5: Exploded view of final assembly

Table 5 lists all of the components in the assembly. The final design chosen was reviewed multiple times by the team to ensure sponsor satisfaction and simplicity. The team believes this design is as simple as it could be while still abiding by the sponsor's requests. Each part of the assembly acts as a critical component and cannot be removed without jeopardizing the

integrity of the machine. On the other hand, adding more complexity to the design would not be justified. Torsion machines are meant to be easy and quick to use. The team made sure that it is clear how to operate the machine even if the user has little experience in materials testing.

Table 5: Bill of Materials

Part #	Part Name	Description	Quantity	Unit Cost	Supplier	Cost
Load Generation						
6Z404	Motor	AC Gear Motor, 18rpm, TEFC, 208 - 230/460V	1	\$601.56	Grainger	\$601.56
GS2-10P5	VFD	Variable Frequency Drive, 0.5 HP, AC Drive	1	\$166.00	Automation Direct	\$166.00
Load Application						
2276	Lath Chuck	6-Jaw, 4" Outer Diameter	2	\$174.95	Little Machine Shop	\$349.90
Linear Motion						
2HXB4	Rails	0.5in Thick(Annealed Shaft, Steel, 0.500in D,16in)	2	\$41.80	Grainger	\$83.60
2CNL6	Pillow Blocks	0.5in. (PillowBlock, 0.500 in. Bore, 1.690in L)	4	\$41.83	Grainger	\$167.32
2CNU7	Shaft Support	0.5in. (Shaft Support, 0.500 in. Bore, 1.625in. H)	4	\$25.99	Grainger	\$103.96
Frame						
2HHP8	Motor Shim	0.75in stock (Bar, Rect., Steel, 1018, 3/4 x 1in, 1Ft. L)	1	\$9.05	Grainger	\$9.05
3DRT8	Motor Baseplate	0.125in Sheet (Flat Stock, LCS, Hot Rld., 1/8in T, 1Ft. L)	1	\$16.49	Grainger	\$16.49
3DRU7	Free End Baseplate	0.25in Sheet (Flat Stock, LCS, Hot Rld., 1/4in T, 1x1 L)	1	\$22.59	Grainger	\$22.59
3DRR5	Long Support Tube	0.125in Th (Tubing, Sq, 1015 LCS, 1OD x 1/8in T, 6 Ft. L)	2	\$19.71	Grainger	\$39.42
4YUL5	Small Thick Support	0.25in Th (Sq Tube, 304SS, 1 OD Sq x 3/4 ID Sq 6ft)	1	\$47.48	Grainger	\$47.48
2HHW5	Free End Stand	1in Stock	1	\$25.55	Grainger	\$25.55
2EYG6	Rod	Aluminum 6061, 4in D x 12in L	1	\$105.70	Grainger	\$105.70
8290T15	Rod	Unpolished, 1117 Carbon Steel, 0.75in D x 12in L	1	\$7.79	McMaster	\$7.79
Miscellaneous Costs						\$98.54

Total Cost	\$1,844.95
------------	------------

4.3 Design for Reliability

Although the team only had 1 semester to fully design the torsion machine, it is expected to last a long time. Each part of the design was analyzed and chosen carefully based on theoretical calculations. As long as specimens do not exceed the shear strength of the materials the team was told it would be testing the machine should not yield or fail. However, almost every machine has the potential to malfunction due to unforeseen circumstances. See Appendix C for a FMEA (failure modes and effects analysis) the team has created for the torsion machine. This diagram is important to understand because it highlights the major ways the machine could fail and gives prevention steps to avoid this.

As shown in the FMEA the main reliability concerns for the machine are the grip strength of the chucks, misalignment of the linear rails, and fastener failure. In order to ensure proper grip strength over time, the team recommends using an attachment to the key to increase the applied moment when tightening down the chuck teeth. It is expected that after some time the linear rails will become misaligned. In order to prevent this their alignment should be checked before and after each use with a straight bar. The nuts that hold the rails in place should also be checked in case they loosen due to loading or vibration. The last major reliability concern the team has for the machine is fastener failure, particularly on the free end. It is possible for any of the screws to fatigue after multiple uses. In order to prevent this the user should check the fasteners before every use and replace them if any yielding is observed.

In order to ensure the structural integrity of the frame and machine, FEA was performed on the critical parts of the frame as shown in Figure 6. These analyses proved that the team's theoretical calculations were accurate and the machine should hold up perfectly under the expected loads. As seen in the Figure 6, the highest stress felt by the frame is approximately 18 MPa which is well under the yield stress of the material which is 620 MPa. Therefore, the frame will be more than adequate to handle the stresses being applied throughout the system. Further FEA analysis can be found in Appendix B.

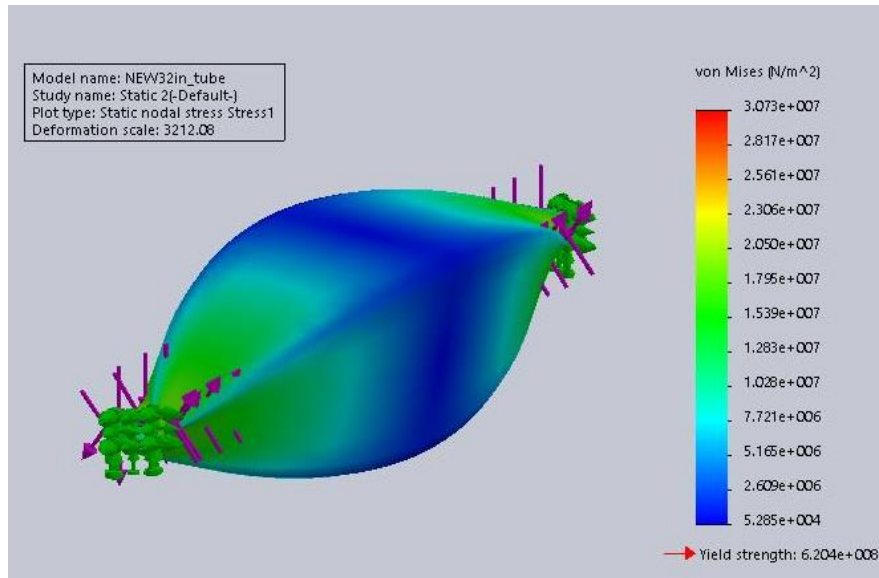

Figure 6: FEA Analysis performed on a support bar

During performance testing, the machine was able to break an aluminum specimen without any complications. The only issue with the tester was that the chucks were unable to grip the cylindrical specimens without slip. Therefore, it was necessary to use specimens with hexagonal grips that allowed for the chucks to firmly grasp. This issue was expected and one of the prominent issues already faced by the AFRL. Moving forward the team is looking into way of inducing friction between the chuck jaws and the specimen grip lengths to allow for the cylindrical specimens to be tested accurately.

Due to the components selected for the design, and the materials used, as long as the proper maintenance is performed, this machine is expected to last as long as the sponsor requires. This is expected because after an analysis of the forces and stresses applied throughout the tester, it was determined that all components have a high safety factor. Therefore, as long as the machine is used for the job it was designed for, it should perform that task with little to no problems.

4.4 Design for Economics

When tasked with building this tabletop torsion tester for the AFRL, the team was constrained to a budget of \$2,000. With this constraint, the team was tasked with delivering a finished product that could be implemented with little to no extra effort from the employees at Eglin Air Force Base. Taking a look at Figure 7 below, a breakdown of how the budget was allocated can be found.

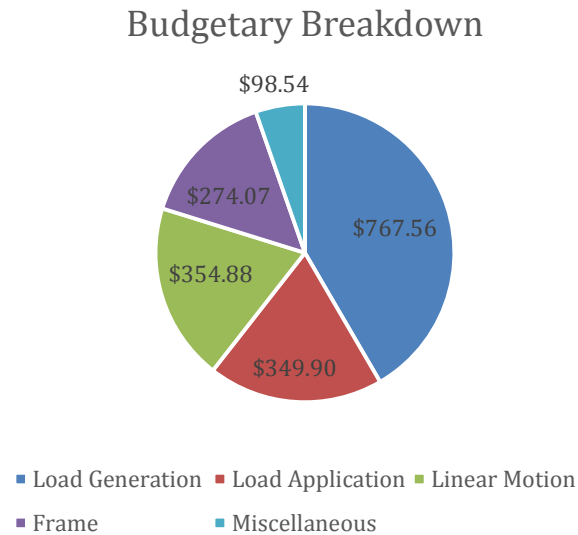

Figure 7: Breakdown of budget by category

Overall, the entire design cost \$1,844.95 which is greater than \$150 under budget. Figure 7 breaks down the budget into 5 categories: Load Generation, Load Application, Linear Motion, Frame, and Miscellaneous. Load Generation required the largest chunk of funding due to the high cost of the motor and variable frequency drive (VFD) purchased to control the motor. The Load Application aspect of the design consist of the two 6-jaw chucks used to hold the specimen during testing. The Linear Motion includes everything necessary to allow for the one degree of freedom on the non-twisting end of the machine. The Frame costs are due to the materials necessary to build the structure of the tester, and Miscellaneous accounts for all other expenses. Looking back at Table 5, the cost of each specific component is listed.

Currently, there are many torsion testing machines on the market that are comparable to the one designed by the group. However, these machines are typically very expensive. Figure 8 shows a

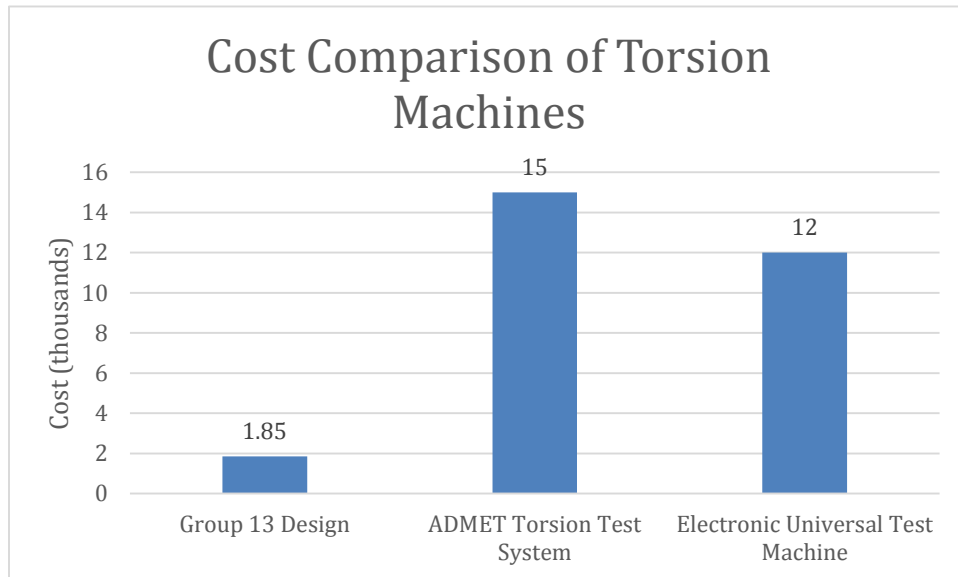

Figure 8: Comparison of similar torsion machines on market

price comparison between our machine and those readily available on the market. Two machines similar to the one designed by the team were used to compare how much cheaper our design was. The Group 13 machine costs a fraction of those found on the market. One of the main reasons for such a reduced cost is that our design does not need to provide a way to measure the strain applied to the sample, and the tools used to measure the stress applied are already in place at the AFRL. This significantly reduced the cost of the machine and allowed for the majority of the budget to be spent on the mechanical aspects of the design.

4.5 Operation Manual

4.5.1 Functional Analysis

It is important for the user to understand the different components of the torsion machine and how they work. Figure 9 below shows a functional analysis diagram of the machine. This diagram breaks down the machine into 5 major components and explains how each part accomplishes its required task. When all of these components work together the user is able to complete an accurate torsion test on a specimen.

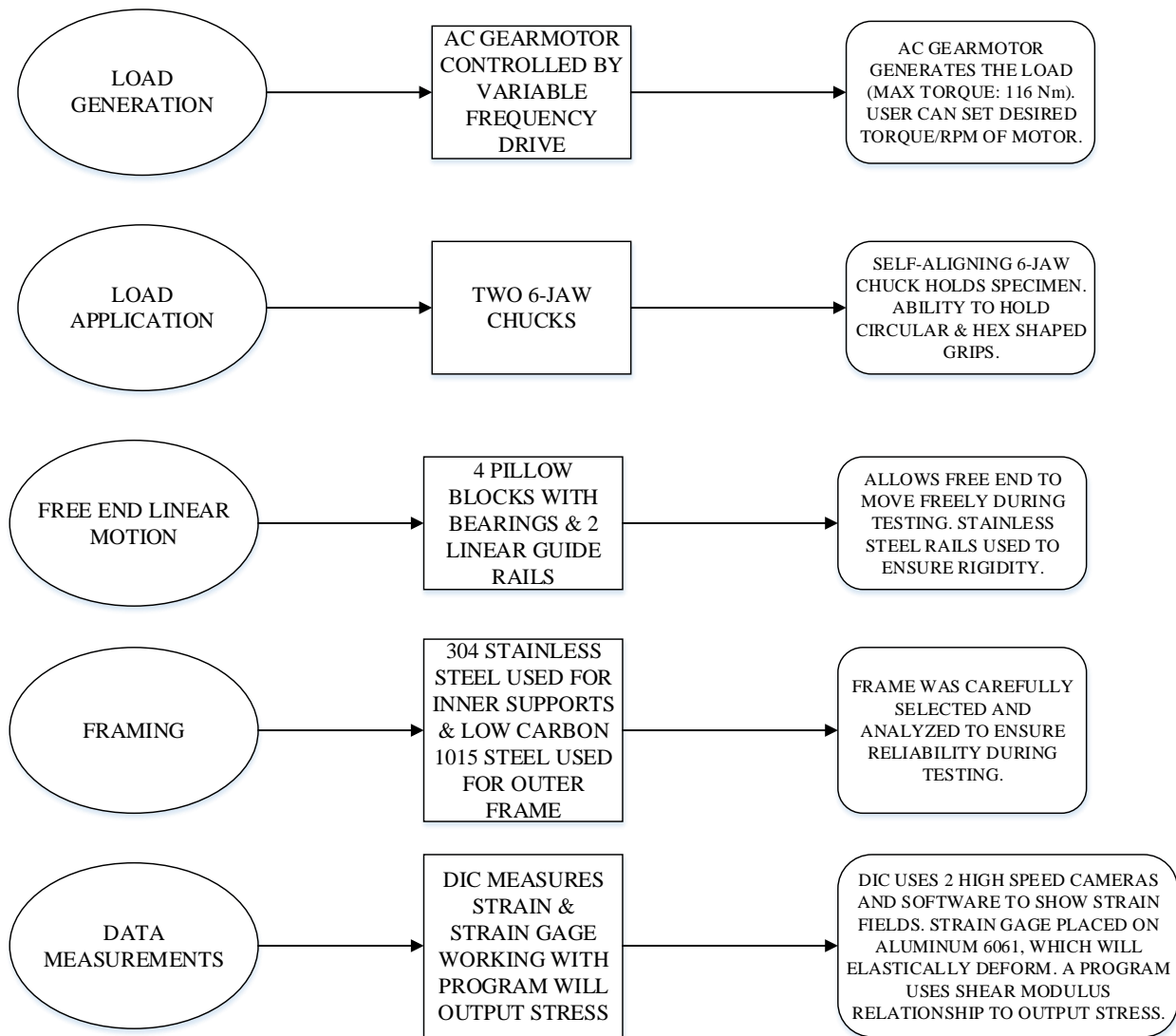

Figure 9: Function analysis of torsion machine

4.5.2 Product Specification

One of the main benefits of this torsion tester is its small size. Figure 10 shows the major dimensions of the machine. It should be noted that similar torsion testers on the market are much larger than this one. As a result, this tester has the ability to be easily moved by two people if necessary and can fit onto a standard table.

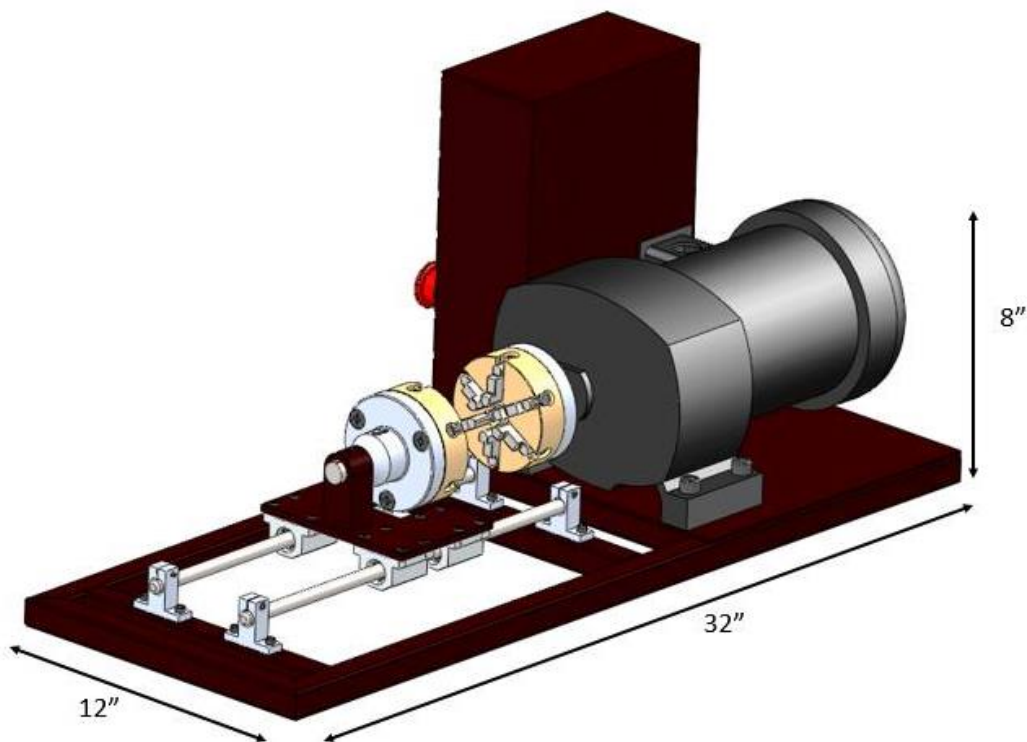

Figure 10: CAD rendering of torsion machine with dimensions

The motor information can be found in Figure 11 below. This picture contains all of the important characteristics of the motor. For more motor information please reference the motor manual provided with the torsion tester. This motor is rated to have a maximum output of 116 Nm, which was more than adequate for this design which required an output of around 100 Nm.

For information regarding the VFD properties, please reference the manual provided with the torsion tester, or it can be found online at:

<https://www.automationdirect.com/static/manuals/gs2m/gs2m.html>.



Figure 11: Motor baseplate information

This torsion tester has been design to test specimens with the geometries found in Table 1, discussed earlier. These samples are quite small, with a total length of less than 60 mm, however the machine is capable of handling specimens that are up to 180 mm in length. The diameter of the specimens tested is limited by the size of the chucks. The specimens must also have a geometry that will not require greater than the torque applied by the motor, so hollow small specimens are recommended.

4.5.3 Assembly

Figure 3 is a 3D CAD rendering of the overall design. Figure 4 shows the overall assembly of the torsion tester in a simpler 2D CAD rendering with labels.

The free end of the machine was custom and therefore a critical part of the machine. For this reason, its assembly on its own can be found in figure 12.

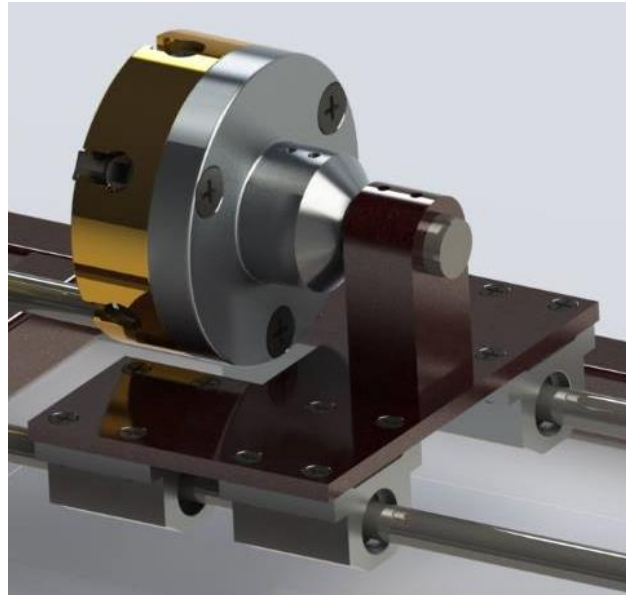

Figure 12: Free end assembly

4.5.4 Operation Instruction

It should be noted the machine must be hooked up to an electrical outlet rated for 120V. Following are the steps needed to operate the torsion tester. It is recommended that the user uses safety goggles while using the machine.

For power supply to VFD wiring setup, refer to Chapter 2, Section 8 of the VFD User Manual provided.

To wire the VFD to the motor make the following connections:

White (VFD) → Motor wires 3 & 9

Red (VFD) → Motor wires 2 & 8

Black (VFD) → Motor wires 1 & 7

Ground (VFD) → Green screw in motor wire housing

To perform a torsion test follow these steps:

1. Perform necessary maintenance checks
2. Clamp machine to table

3. Loosen chucks with key provided to allow for specimen placement
4. Tighten chuck attached to motor shaft first using key (do not exceed grip length)
5. Slide free end chuck to cover specimen grip and tighten
6. Plug VFD into electrical outlet
7. Using VFD keypad, insert required program settings from motor baseplate
8. Set potentiometer to desired RPM/torque
9. Click green RUN button on VFD to begin test
10. Watch specimen closely and click red STOP button once desired failure point is reached
11. Use key to open chucks and remove sample
12. Fully close chucks after removing sample
13. Perform final maintenance checks recommended in this manual

4.5.5 Troubleshooting

Although the torsion tester was designed to have a high reliability, it is always possible for something to go wrong during operation. This section is meant to be a tool for the user in case something goes wrong with the machine.

VFD not turning ON

- Make sure electrical plug is in outlet
- Make sure all wiring is correct and securely fastened
- For more complex problems with the VFD please refer to chapter 6 in the VFD manual provided

Sample is slipping

- Use proper tightening key to tighten the chucks
- If using cylindrical grips try using another grip geometry such as hex grips
- Induce friction on sample grips by scratching grip surfaces

Chuck is locked in position (unable to turn key)

- Fully loosen scroll and remove all teeth
- Replace teeth in order as shown below

- Insert teeth separately by watching for gap in scroll to pass while turning

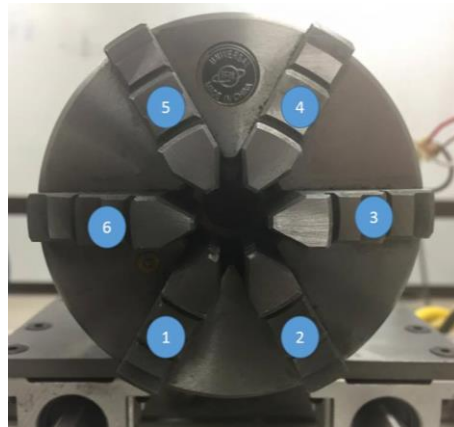

Free end is not moving smoothly on linear rails

- Check that rails are aligned and perfectly straight
- Grease rails

Free end chuck is moving during testing

- Tighten down set screws

High motor temperature (motor is hot to the touch)

- Turn off machine for at least an hour

Motor shaft is not spinning

- Check that connections between motor and VFD are secure

4.5.6 Regular Maintenance

As with any machine, this torsion tester requires some maintenance from time to time.

VFD and motor

- Please refer to chapter 6 section 2 for monthly and annual inspection directions in the VFD manual to ensure optimal performance
- Also refer to motor manual for more information

Coupler

- Before and after testing, check couplers for any sort of deformation which may include cracking, warping, and/or shearing

Chucks

- Regularly check teeth for any deformations
- Fully open and close teeth before use to ensure proper alignment of teeth
- Refer to chuck manual provided with machine for more information

Free end

- Regularly check that the set screws are fully tightened

Linear rails

- Check all fasteners before use to ensure proper alignment
- Apply grease as needed to rails

Frame

- Perform a visual check of frame and welds for structural integrity before use
- Ensure all fasteners are fully tightened before testing

4.5.7 Spare parts

For any major part replacement please reference the bill of materials provided for the part number and vendor. The torsion tester comes with 2 chuck keys, and some extra fasteners which are listed below.

- 8 10-32 x 5/8 Button Head Socket Cap Screw
- 8 #10 Flat washer SAE
- 16 10-32 x 3/4 Flat Head Socket Cap
- 16 10-32 Hex Nut with Lock Washer
- 4 7/16-14 x 2 Socket Head Cap Screw
- 4 7/16-14 Nylon Insert Lock Nut

5. Prototype Testing

Once the tabletop torsion machine was fully assembled it was time to test it. The sponsor provided the team with nine aluminum cylindrical grip specimens to test with. Since the team does not have any of the data measuring equipment on campus, all the team can test for is specimen failure and structural integrity of the machine during and after testing.

During the first test with one of the specimens, it was found that the grips were slipping in the chucks. The team contacted the sponsor and it was determined that this was not unexpected. In order to properly test the machine to see if it was able to break the specimen, the team asked the machine shop at the College of Engineering to cut the specimen grips into a hexagonal shape. This ensures that the specimens will not slip in the 6-jaw chucks. This was proven during the second test and the torsion machine successfully broke the specimen as it was supposed to. The machine also successfully withstood the forces felt during testing. This proved the proper FEA analysis was performed during the design process. A picture of the first broken specimen can be found in Figure 13. As shown in the picture, the specimen broke in the middle of the gage length which proves the highest stress was felt in the middle. This is a direct result of proper alignment of the chucks and free end as well as proving the free end chuck did not rotate during testing.

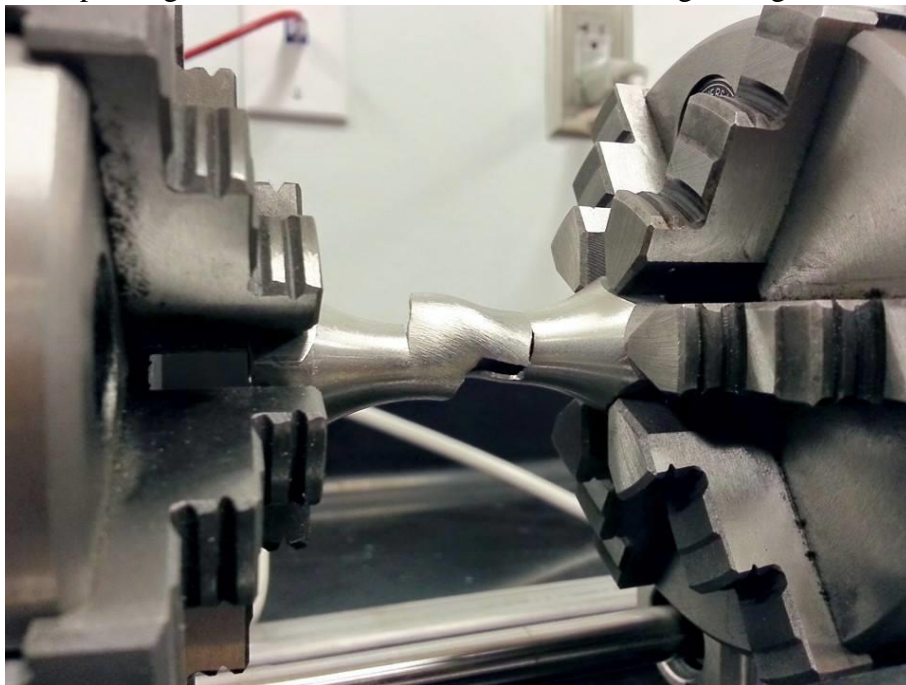

Figure 13: Result of first prototype test

6. Considerations for Environment, Safety, and Ethics

As with any machine designed and manufactured, certain considerations must be taken into account to ensure safe and proper use. Since the machine will be operated in the materials testing lab by a professional at Eglin Air Force Base there were no environmental considerations for this project. As for ethical considerations, this machine was designed to be owned and operated by the AFRL and the operation of this tester should follow all ethical standards set by that establishment. However, since this is a machine with moving and electrical parts there were some safety considerations when designing it. The team made sure the motor and VFD were rated to be safely used with a standard electrical outlet. Also, the team contacted the tech support from the motor vendor and made sure it would not overheat during expected testing conditions. The team also made sure any electrical wire is completely insulated. Additionally, the team will install an emergency stop switch to turn off the motor in case it needs to be shut off instantly. Although the machine was built to test ductile materials, the team recommends the user to wear safety goggles during testing.

7. Project Management

7.1 Schedule

The critical path for this design can be broken down into two main stages: ideation and construction. The ideation stage of the build took up the entire fall semester. For this design, the team first had to approach the problem and determine the best components for the overall design. The design was broken up into five main categories: load generation, load application, load measurement, linear motion, and frame. With the project now broken down into these categories, research was performed to determine what products could be purchased or made to provide the best complete design. However, before finalizing any components for the other four categories, a decision first had to be made on the load generation aspect of the project. The load generation category included the motor and how the motor would be controlled. Due to the large cost of these two components, it was required that these be purchased first, and then the rest of the design would be adapted and produced out of the remaining budget. Therefore, for a large portion of the fall semester, much time was dedicated to selecting the optimal motor and motor controller, until finally settling on the AC gearmotor and VFD selected. After selecting these two components, the load application, linear motion, and frame were easily chosen. As noted previously in this document, the load measurement tools are provided by the AFRL, so this category was not a concern. By the end of the fall semester, the ideation stage was nearly complete. The final step of this stage was to purchase all the necessary components and stock material to build the machine.

Purchasing occurred at the end of the fall semester as well as the beginning of the spring semester. During this time, no progress was able to be made. Construction began by mid-January once most of the purchased items were received. Due to a backup in the shop, the construction process took longer than expected and was not finished until the last week of March. During this time, the motor and VFD were connected and tested to allow for proper testing once the entire design was finished. After the completion of construction, testing was performed to ensure that the final design met the requirement provided by the sponsor.

7.2 Resources

Once the components of the design were ordered and received, the construction of the design was handled primarily within the FAMU-FSU College of Engineering Machine Shop. Because most of the senior design groups send their materials to the machine shop at approximately the same time of the year, it can be very difficult to get the machining necessary for the design performed in a timely manner. Fortunately for the design team, one of the members has worked in the machine shop on previous occasions and did not have to rely solely on the machinists to fabricate the parts necessary to construct our machine. The water jet was used extensively to cut the appropriate dimensions for many of the pieces of the design. A lathe was also used to create the transmission and free end couplers. A few more tools from the machine shop were used to complete the fabrication of the parts for the torsion tester. The machinists were required to perform the welding and force fitting part of the design because of safety concerns.

7.3 Procurement

The budget allocated for this design was \$2,000. When compared to other torsion testers on the market, this budget is quite low. However, this \$2,000 was only for the materials and components required to build the mechanical aspects of the design, and was not intended to include and stress or strain measurement devices. As discussed previously in this document, the strain gages for this design used to measure the stress experienced by the samples, and all subsequent signal conditioning equipment, was to be provided by the AFRL. To measure the strain in the sample, the DIC currently used by the AFRL would be used. Therefore, the budget of \$2,000 was adequate for the production of the tabletop torsion tester.

Out of the \$2,000 provided, the group spent \$1,844.95. The materials and components used for the design came from four vendors. The 6-jaw chucks used to grip the sample were procured from LittleMachineShop.com. The variable frequency drive necessary to control the motor was purchased from AutomationDirect. The raw material required to machine the free-end coupler between the chuck and baseplate were received from McMaster-Carr. The remainder of the materials for the build including the motor, linear guide system components, as well as raw materials for the frame and transmission coupler were procured from Grainger. A full Bill of Materials can be found in Table 5 earlier in this document.

7.4 Communication

Communication between the members of the design team was through text message, email, and a private Facebook group. Although this method of communication was adequate for the purposes of the team, in future projects it is recommended that another service other than Facebook should be used for communication and file sharing purposes. Although Facebook was very useful for sharing pictures and ideas quickly, it was not the ideal platform for sharing files such as reports and presentations. Without proper search or sort functionality, Facebook became very cluttered when searching for a specific document. Therefore, in future projects the team recommends using a service that is dedicated to file sharing such as Dropbox or Google Drive.

Communication between the design team and the sponsor was primarily handled through biweekly video conferences, as well as email. The team found that this arrangement was very beneficial because it allowed for ideas and concerns to be voiced in a “face-to-face” scenario. The sponsor was able to provide the group with valuable insight into the background of the project and why this design was important to the work being performed at the AFRL, as well as provide constructive feedback about the project throughout the year.

The team also met with the faculty advisor once a week throughout the year to provide updates as well as receive insight into how to approach the challenges of the design. The faculty advisor was also included in the Facebook group so that her input could be provided quickly on any reports or presentations that were posted to the discussion board. Altogether the group had minimal difficulties with communication between each other, the sponsor, and advisor.

8. Conclusion

Materials testing is a very important part of engineering. The AFRL at Eglin Air Force Base test many different materials and utilize many testing methods. They use the data from these tests for their models and simulations. Their current torsion machine is very large and inaccurate when testing small specimens. They have assigned the team to design and manufacture a tabletop torsion tester. The sponsor at AFRL gave the team design and constraints and left the rest to the team. Over the past two semesters, the team has gone through multiple design concepts and eventually built the final prototype. This was accomplished by consulting with the team's advisor, other professors, tech support experts, and rigorous analysis on design concepts. The team was successful in developing an optimal design because the torsion machine was split into each component and analyzed separately. This allowed the team to look at the design in sections instead of as a whole and combine each optimal component to get the best possible product. The final design consists of an AC gear motor, 6-jaw chucks, two rail ball bearing guide system, and steel framing. The team has run successful tests in breaking the aluminum specimens provided by the sponsor.

11.1 Future Recommendations

If this project were to be continued next year, the team recommends the future team to implement cyclic loading, develop a user interface that allows for complete motor control, and improve the stress and strain measurement methods.

We think the team wasted a lot of valuable time trying to figure out how to control a motor. Since the team only consisted of mechanical engineers, no one had enough experience to know how to approach this problem. The team initially set very lofty goals that at the time seemed realistic, but after further consideration were deemed not feasible with the time, budget, and resources available. Therefore, the team would set more realistic goals and focus primarily on the main customer requirements, and then add any extra features later if possible.

References

[1] Kalu, N., and A. Joseph. *WiseGeek*. Conjecture, n.d. Web. 28 Mar. 2015.

[2] "EXpert 9000 Torsion Tester." *ADMET*. N.p., n.d. Web. 28 Mar. 2015.

[3] "Tentative Method for Metals in Water." *Journal (American Water Works Association)* 60.6 (1968): 739-42. Web.

Appendix A

Calculation for necessary applied torque to break Titanium
Ti-6Al-4V specimen

$$G := 44 \cdot 10^9 \text{ Pa} \quad \text{Shear Modulus}$$

$$D := .418 \text{ in} = 10.617 \text{ mm} \quad \text{Outer Diameter}$$

$$d := .358 \text{ in} = 9.093 \text{ mm} \quad \text{Inner Diameter}$$

$$\tau_{\max} := 550 \cdot 10^6 \text{ Pa} \quad \text{Shear Strength of specimen}$$

$$c := \frac{D}{2} = 5.309 \times 10^{-3} \text{ m} \quad \text{Distance from center to surface}$$

$$J := \frac{\pi \cdot (D^4 - d^4)}{32} = 5.763 \times 10^{-10} \text{ m}^4 \quad \text{Polar moment of inertia}$$

$$\text{Torque} := \frac{\tau_{\max} \cdot J}{c} = 59.705 \text{ N} \cdot \text{m} \quad \text{Needed applied torque}$$

Calculation for necessary applied torque to break hollow Aluminum specimen

$$G := 28 \cdot 10^9 \text{ Pa} \quad \text{Shear Modulus}$$

$$D := .418 \text{ m} \quad \text{Outer Diameter}$$

$$d := .358 \text{ m} \quad \text{Inner Diameter}$$

$$\tau_{\text{max}} := 283 \cdot 10^6 \text{ Pa} \quad \text{Shear Strength of specimen}$$

$$c := \frac{D}{2} = 5.309 \times 10^{-3} \text{ m} \quad \text{Distance from center to surface}$$

$$J := \frac{\pi \cdot (D^4 - d^4)}{32} = 5.763 \times 10^{-10} \text{ m}^4 \quad \text{Polar moment of inertia}$$

$$\text{Torque} := \frac{\tau_{\text{max}} \cdot J}{c} = 30.721 \text{ N} \cdot \text{m} \quad \text{Needed applied torque}$$

Appendix B

FEA analysis on support frames

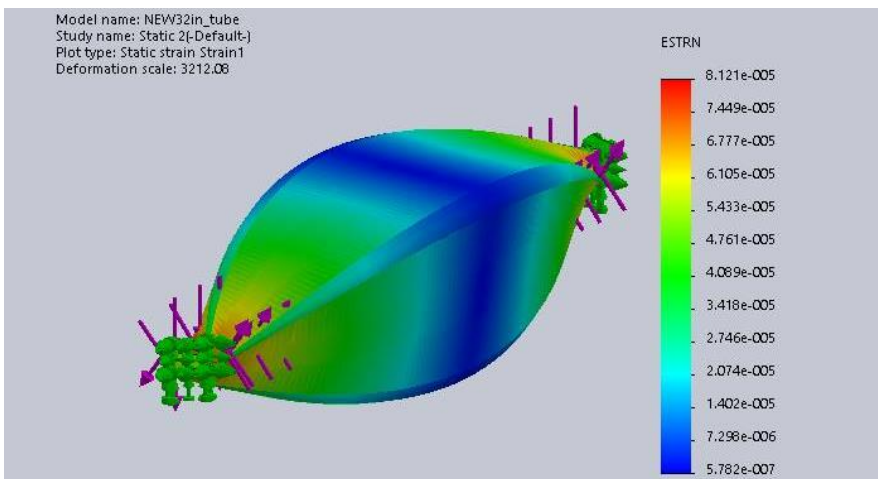
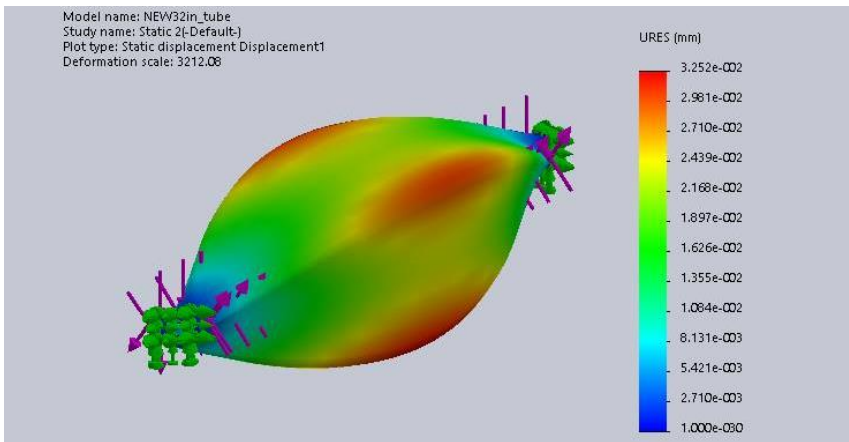
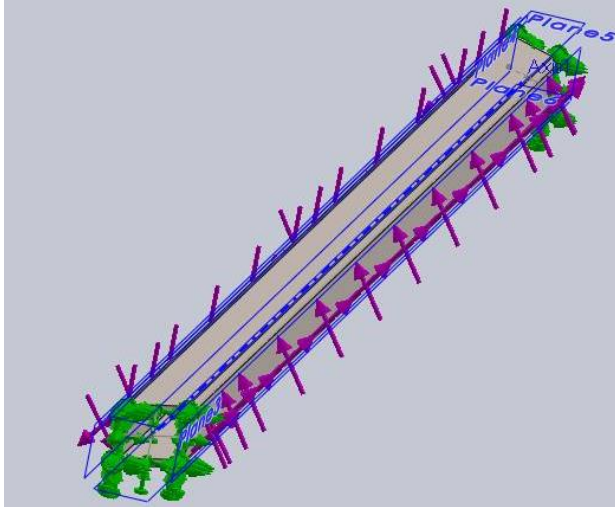

Appendix C

FMEA

Key Process Step or Input	Potential Failure Mode	Potential Failure Effects	S E V	Potential Causes	O C C	Current Controls	D E T	R P N	Actions Recommended	Resp.
What is the Process Step or Input?	In what ways can the Process Step or Input fail?	What is the impact on the Key Output Variables once it fails (customer or internal requirements)?	How Severe is the effect to the customer?	What causes the Key Input to go wrong?	How often does cause or FM occur?	What are the existing controls and procedures that prevent either the Cause or the Failure Mode?	How well can you detect the Cause or the Failure Mode?		What are the actions for reducing the occurrence of the cause, or improving detection?	Who is Responsible for the recommended action?
Load Application (Gripping of Sample)	Slippage of sample during operation	Inaccurate data	6	Not enough clamping force	7	Tighten with adequate force/tool	5	210	Use proper tool to apply the proper holding force	User/Tech Expert
Load Generation (Motor)	Overheat or burnout	Renders machine unusable. Large cost of replacement	10	Overuse/misuse of VFD	2	Proper motor settings put into VFD. Also limitations of motor known by operator	4	80	Read motor/VFD manuals. Don't use for extended periods of time. Be aware of motor temperature during use.	User/Tech Expert
Motor Control (Variable Frequency Drive)	Loose connections	Unable to properly control the motor	8	Moving the apparatus/constant use	3	Tightened connectors	5	120	Check connections before use	User/Tech Expert
Linear Motion (Free end)	Deflection in rails	Introduction of other stresses (false readings)	9	Improper material chosen	2	Material selection followed, FEA performed	4	72	Check rails before and after use, noting any changes	User/Tech Expert
	Misalignment	Introduction of other stresses (false readings)	9	Improper assembly, fasteners loosen over time	5	Proper measures taken during assembly	4	180	Use proper measuring tool to ensure alignment before use	User/Tech Expert
	Fastener Failure	Require replacement and reassembly	7	Improper selection of fasteners	3	Material selection procedures followed	6	126	Perform routine maintenance/checks	User/Tech Expert
Frame	Yielding	Require replacement and reassembly	9	Improper selection of materials used	2	Material selection procedures followed, FEA performed	6	108	Clamp to optical table and also perform routine checks	User/Tech Expert
	Failure at joints	Require replacement and reassembly	9	Stress analysis at welding was miscalculated	2	Stress analysis performed	6	108	Perform routine maintenance/checks	User/Tech Expert
Load Measurement (Coupler & Strain gauges)	Coupler plastic deformation	False stress measurements and eventual failure	8	Underestimated max stress being applied	2	Theoretical calculations performed to ensure reliability	3	48	Ensure specimen tested does not require a higher load than what the machine is rated for	User/Tech Expert
	misalignment of strain gauges	Inaccurate measurements	6	User error	5	Expert installation	3	90	Ensure proper placement, compare values to expected values	User/Tech Expert
	Loss of strain gauge sensitivity	Inaccurate measurements	6	Wear & tear	6	Recommended replacement after a period of time	3	108	Perform routine maintenance/checks	User/Tech Expert

Biography

Brendan Keane – Team Leader

Brendan is a senior mechanical engineering student at Florida State University. He is graduating in May of 2015 and has had 3 internships at Florida Power & Light. After graduation, he will begin working at Lockheed Martin Missiles and Fire Control as a Manufacturing Engineer.

Logan McCall – Fabrication Advisor

Logan is a Florida State student that was born and raised in Panama City, Florida. He is a senior Mechanical Engineering student that plans on graduating in the fall of 2015. His background comes from previous work experience throughout college, and plans on joining working community upon graduation.

Reginald Scott – Financial Advisor

Reginald is a senior mechanical engineering student at Florida A&M University. He has obtained two internships. One of which was as a design engineer at TECT Power. The second was a manufacturing engineer at Nestle Waters. Reginald is expected to graduate in May 2015. He then will be pursuing an entry level full time job within the mechanical engineering field.

Mark Swain – Administrative Coordinator

Mark is a senior mechanical engineering student at Florida State University. He has performed research with multiple teachers during his time at FSU. After graduating with a BS in May 2015, Mark plans to pursue his MS in mechanical engineering through the BSMS program offered here at FSU.