

Final Report

Team 8: AUVSI Design Competition

SUBMITTED: APRIL 10, 2015

ADVISORS: DR. FRANK AND DR. ALVI

SPONSORS: DR. SHIH AND FIPSE

INSTRUCTORS: DR. GUPTA AND DR. FRANK

AUTHORS: CHRISTOPHER BERGLJUNG, JERMAINE
DICKY, WILLIAM DI SCIPIO, DAVID HEGG,
GAVARNI LEONCE, JOHN MURNANE, AND TAVARIUS
SLAUGHTER

CONTENTS

List of Figures	iv
List of Tables	v
Abstract	vi
Acknowledgments	vii
I Introduction	1
II Background and Literature Review	2
III Concept Generation	3
III-A Proposed Designs	3
III-A1 Design 1	4
III-A2 Design 2	4
III-A3 Design 3	5
III-B Selection	6
IV Final Design	6
IV-A Mechanical Components	7
IV-B Electrical Components	8
IV-B1 Motor Details	9
IV-B2 ESCs	9
IV-B3 Batteries	9
IV-B4 Flight Time for Quadrotor	9
IV-B5 Electrical Diagram	10
IV-C Design for Manufacturing, Reliability, and Economics	10
IV-C1 Design for Manufacturing	11
IV-C2 Design for Reliability	14
IV-C3 Design for Economics	16
IV-D Operation Manual	18
IV-D1 Functional Analysis	18
IV-D2 Project/Product Specification	19
IV-D3 Quadrotor Frame Assembly	20
IV-D4 Electrical Component Assembly	23
IV-D5 Operation Instruction	25
IV-D6 Troubleshooting	27
IV-D7 Regular Maintenance/ Service	27
IV-D8 Spare Parts	28
IV-D9 Summary	28
V Design of Experiments	28
V-A Experimental Testing	28
V-B Results	30
V-C Future Testing for Transitional Flight	34
VI Considerations for Environment, Safety, and Ethics	35
VI-A Environmental Considerations	35
VI-B Safety Considerations	35
VI-B1 Pre-Testing	35
VI-B2 Pre-Flight	36
VI-B3 In-Flight	36
VI-C Ethical Considerations	36
VII Project Management	36
VII-A Schedule	36

VII-B	Resources and Facilities	37
VII-C	Procurement	37
VII-D	Communication	38
VIII	Conclusion	39
	References	41
	Appendix A: Part Drawings	i
	Appendix B: FMEA	viii
	Appendix C: Gantt Charts	ix
	Biography	xiii

LIST OF FIGURES

1	Design Option 1	5
2	Design Option 2	5
3	Design Option 3	6
4	Quadrotor and Hybrid Aircraft	7
5	Electrical System Diagram	10
6	Attachment assembled and exploded	12
7	Clamp and motor mounts assembled and exploded	13
8	Example epoxy template.	13
9	FEA on aluminum 6061 beams.	15
10	Breakdown of expenses along with percentage of total \$1500 budget.	17
11	Cost comparison of purchased components with similar products.	18
12	Senior Telemaster Plane with Quadrotor Attachment.	20
13	Base Plate Attachment.	20
14	Front and Rear Assembly junction of base plate and 6061 Square Aluminum	21
15	Placement of foam padding over the base.	21
16	Clamps secure the carbon fiber rods in a rigid manner.	22
17	Components and assembly of carbon fiber tubes and motor with mounts	22
18	Propeller placed onto motor.	23
19	Output cable and RC receiver.	23
20	Altitude vs. Time	31
21	Yaw vs. Time	32
22	Flight Plan	32
23	Pitch vs. Time with Respect to Speed	33
24	PWM supplied to motors vs. Time	34
25	Breakdown of expenses along with percentage of total \$1500 budget.	38

LIST OF TABLES

I	Aircraft Type Decision Matrix	4
II	Design Option Decision Matrix	6
III	Thrust Per Motor Calculations	8
IV	Thrust Calculations	8
V	Total parts list and quantities.	11
VI	Additional motor specifications for Cobra 4510 Brushless DC motor.	14
VII	Various material mechanical properties.	15
VIII	List of expenses for each purchased part and the corresponding cost.	16
IX	Total parts list and quantities.	19
X	Motor Data Sheets.	19
XI	ESC Data Sheets.	19
XII	Battery Data Sheets.	20
XIII	List of expenses for each purchased part and the corresponding cost.	39

ABSTRACT

The two year goal of this project is to compete in the 2016 Association for Unmanned Aerial Vehicle Systems International (AUVSI) competition. This year's goal was to design and build a quadrotor attachment for an RC plane that will give it autonomous vertical takeoff and landing capabilities (VTOL). The main challenge of this is trying to stabilize an unsymmetrical aerial vehicle. Team 8 decided that a micro-controller with adjustable proportional-integral-derivative (PID) parameters could be used to account for the unsymmetrical shape. After extensive testing, it was found that stable autonomous takeoff and landing was possible with the micro-controller after different parameters in the controller were adjusted. With autonomous VTOL completed, next year's team has the ability to complete the other aspects of this project and be highly competitive at the 2016 AUVSI competition.

ACKNOWLEDGMENTS

Team 8 would like to thank Dr. Shih for funding this project and advising Team 8 throughout the process. Dr. Frank has been helpful with aiding in the electrical aspects of the project. Additionally, Dr. Alvi has provided assistance with specific aeronautical questions and calculations. Dr. Shih even went as far as to provide Team 8 with the opportunity to test his quadcopter in order for the team to acquire a better understanding of the systems. Moreover, Team 8 has chosen to design an unconventional aerial vehicle and Dr. Gupta has offered his opinions throughout the research, design, and building of the project.

I. INTRODUCTION

Team 8 has been given the task of competing in an international competition while also working with team members that were abroad during the Fall 2014 semester as part of the Fund for the Improvement of Postsecondary Education (FIPSE) program. The distance between teammates required the team to seek various outlets for effective communication. Among which were email, Skype, and GroupMe. This challenge gave the team experience with communicating by means other than face-to-face when time and space does not allow. Successful means of communication were achieved in the development of an Unmanned Aerial Vehicle (UAV) for this senior design project.

The Association for Unmanned Vehicle Systems International (AUVSI) hosts an annual competition in which schools from around the world can test their engineering skills against each other by building the best UAV for specified tasks or missions [1]. The 2015 AUVSI Student Unmanned Aerial Systems (SUAS) competition has the primary mission requirements of autonomous flight, object detection, and reconnaissance. These tasks are to be done as quickly and accurately as possible while maintaining autonomous flight. To complete these tasks, each team is given 40 minutes and then must return the aircraft to its control station [1]. Last year's senior design team was unable to compete in the AUVSI competition, but competed in another competition and was able to achieve autonomous flight and data acquisition successfully. The biggest problem they experienced was the inability to take clear photos for object detection and to perform an autonomous takeoff and landing.

To address the issues experienced by the team last year, Team 8 decided on a goal statement that would allow for these problems to be corrected. The goal statement is as follows:

"The goal of this project is work effectively as a team to create the best possible aircraft for future success at the 2016 AUVSI SUAS Competition."

This statement allowed Team 8 to take into account the shortcomings of last year's aircraft and to design a solution that would be better equipped to address those problems. Originally, the plan was to design a multirotor aircraft so that the camera could have a stationary platform to take clear pictures and to facilitate autonomous take off, landing, and waypoint navigation. However, when researching this technology, Team 8 discovered that the average flight time for multirotor aircraft is about 15 to 20 minutes [2]. This limited amount of flight time would not be adequate to properly complete the mission and underutilized the allotted 40 minutes of mission time. Per competition rules, the UAV does not have to fly for a specific amount of time, however, in order to complete various mission objectives, a multirotor would have the disadvantage of having to return to the command center during the mission to exchange the batteries.

While still in the research phase, Team 8 discovered a UAV design by Latitude Engineering which was thought to be the ideal vehicle for the AUVSI competition [3]. This UAV is shaped similar to an airplane but features four vertical facing propellers in addition to a horizontal facing propeller. The four vertical facing propellers give the UAV the abilities of a multirotor by enabling Vertical Takeoff and Landing (VTOL), while the fifth rotor gives it the ability to achieve fixed wing flight. This is ideal because a multirotor vehicle has to power four motors instead of one, which significantly reduces its flight time compared to a fixed wing aircraft. A hybrid vehicle can incorporate the VTOL capabilities of a quadrotor but still have similar flight time and speed of a fixed wing aircraft.

While this hybrid design is ideal for a UAV, it is a relatively new technology and has little data or supporting information on the design. It took Latitude Engineering a large amount of time to get their hybrid UAV running properly due to the challenges associated with balancing a asymmetrical vehicle with four evenly spaced props. This was further compounded by the need to transition from quadrotor flight to fixed wing flight while in the air. To approach this problem, it was necessary to formulate our

objectives with not only this years team in mind but also the next years team. This years team and next years teams objectives for this project were as follows:

Fall 2014 - Spring 2015

- Design a quadrotor attachment for existing plane
- Acquire ordered parts in a timely manner
- Research stability coding and testing
- Machine and assemble the aircraft for testing
- Test and troubleshoot the system so that autonomous VTOL is achieved

Fall 2015 - Spring 2016

- Review notes and reports from previous year
- Study new rules for the AUVSI 2016 competition and decide which secondary tasks to pursue
- Begin programming for transitional flight
- Test transitional flight
- Adapt autonomous forward flight and making necessary changes for the new design

Though this task was difficult, Team 8 was enthusiastic about working towards completing the task. The difficulty of the challenges and excitement of working on an innovative, developing technology are what motivated Team 8 to proceed with this design.

II. BACKGROUND AND LITERATURE REVIEW

UAV technology has undergone recent developments which have allowed it to become cheaper and more accessible to the general population. Previously, UAVs, or drones, were mainly limited to high end government or military applications. They are now becoming readily available to the civilian world due to their many uses. One of the main fields is search and rescue. By utilizing UAVs, casualties may be reduced and response times of emergency personnel can be decreased. The AUVSI competition focuses on these kind of emergency applications of drones. Hence, each competition involves activities that would be typical in those situations such as, waypoint navigation and object detection and recognition [4].

Continuing with the search and rescue application in mind, Team 8 settled on the hybrid UAV design. As discussed above, a traditional aircraft design was found to be lacking in its takeoff and landing capacities. A quadrotor corrects these problems but brings forth the problem of decreased range and flight time. With both designs having their compromises, the team decided to merge them together in the form of a hybrid UAV. This hybrid design remains largely unproven and the team was eager to learn a new technology. This design contained both mechanical and electrical components that were looked into extensively. This included a micro-controller, motors, propellers, ESCs, batteries, and wiring to name a few.

Team 8 researched the ArduPilot APM 2.6, which is a micro-controller for RC planes or multirotor vehicles which allows for the conversion of a manually piloted aerial vehicle into an autonomous vehicle [4]. The ArduPilot was researched and it was decided by the team that it was the best micro-controller for their application. This was because the APM 2.6 included the necessary hardware and software to control this inherently unstable design with one of them being a powerful proportional-integral-derivative (PID) controller. The PID controller is capable of fine tuning to help stabilize aerial vehicles. Since the hybrid plane is unsymmetrical, this was very important as typical quadcopters are symmetrical but the ability to fine tune the controller will be used to stabilize the vehicle. The ArduPilot would allow for the overcoming of the aerodynamic issues with this design.

When researching the aerodynamic issues the focus was on the drag for forward flight and the ground effect and stability in vertical flight. The drag in forward flight is related to the cross-sectional frontal area of the aircraft [5]. By adding the quadrotor frame, the various arms would increase the drag. However, at the relatively slow speeds that the plane would be flying the drag force is small. The ground effect forces

on the aircraft were an issue that had to be researched as well. It was found that the ground effect height for a helicopter is related to the propeller diameter and ends at about one and a quarter propeller diameter above the ground [6]. It was found that the ground effect, for a quadrotor, affects the aircraft up to at least one rotor diameter above the ground [7]. To account for this effect, it was decided ground effects would be felt up until one and half the diameter of the propeller diameter. With this research, Team 8 noted that the operating procedures needed to be adjusted to quickly get the plane from the ground past this region of ground effect while taking off. Besides ground effect, issues with the stability while in vertical flight were considered. These included the instability of the quadrotor frame with the plane attached as well as instabilities caused by wind gusts on the aircraft body. These would be detrimental with the VTOL flight and the best solution was to limit flying time in those conditions and to properly tune the PID control so that it could best account for these.

For the quadrotor frame it was important to determine the proper parameters. It was found that the general rule of thumb is thrust to weight ratio of 2:1 [8]. To achieve this, it was necessary to take into account the weight of the plane and its subsystems as well as the weight of the quadrotor frame and its subsystems. The weight of the entire aircraft was calculated to be 8,239 grams. It was then necessary to find the motors and prop combination that would give the desired thrust. After selecting the motors, propellers that had an 18.5 inch diameter were selected. This combination of motors and props generated a total thrust of 17,872 grams. This gave the proper thrust to weight ratio while maintaining an ideal weight for the aircraft and considering a safety factor.

This project is one of the few to explore this hybrid design for planes. There are various small groups online on GitHub and various blogs that have attempted this as well. Due to the small amount of people that have attempted this design, there was little, if any, specific literature to learn upon so it was necessary to combine current knowledge of fixed wing UAVs and quadrotor UAVs. So far, the main successful entity has been Latitude Engineering. Their methodology was to not use typical rotating propellers to switch from VTOL to forward flight but instead to have both a dedicated VTOL portion and a dedicated forward flight portion. It was due to their success that it was decided by Team 8 to emulate their design and to further the knowledge on this type of non-rotating hybrid design.

III. CONCEPT GENERATION

With the freedom to move forward with last years design in order to compete in future AUVSI design competitions, Team 8 wanted to have a design that would not only complete the objectives of the competition but also be innovative. Using last years aircraft as a starting point, Team 8 brainstormed ideas on exactly what direction would be optimal for the overall goal of the project. The four ideas that were discussed were to build a multirotor, buy a multirotor vehicle, retrofit the existing plane, or to build a hybrid vehicle using the existing plane. By creating a decision matrix shown in Table I, Team 8 decided that the building a hybrid vehicle, would be the best possible aircraft for future AUVSI SUAS Competitions. This is because the quadrotor aircraft would provide VTOL capabilities which will be beneficial for the design competition. Some other benefits of a hybrid vehicle are hovering capabilities and longer flight time compared to a quadrotor. These are what makes the hybrid design an optimal vehicle for AUVSI competition, and an innovative design to separate itself from competitors.

A. Proposed Designs

To create this design, the frame of the quadrotor would need to be attached to the plane which would create a hybrid aircraft. When designing the frame for the quadrotor attachment, many constraints were taken into account. First, the frame needed to be lightweight in order to obtain vertical takeoff and landing, and to sustain the planes horizontal flight capabilities. Second, the frame needed to be designed with enough strength to firmly support the quadrotor components and to avoid major damage if motor failure was to occur. The attachment needed to be relatively low cost since Team 8 was only allotted

Component	Importance	Fixed Wing	Build Multirotor	Buy Multirotor	Hybrid
Cost	10	9	5	3	5
Build Time	10	9	3	6	4
Weight	4	6	5	5	4
Durability	4	4	7	7	6
Troubleshooting	7	3	6	6	4
Tech. Development	10	4	8	5	10
Future	5	3	7	7	10
Stability	3	5	8	8	8
Payload	5	8	5	5	8
Flight Time	8	7	5	5	8
Horz. Velocity	6	7	5	5	7
Automation	8	8	7	7	5
Airdrop	4	5	8	8	7
Agility	4	5	8	8	6
	Total	553	524	504	570

TABLE I
AIRCRAFT TYPE DECISION MATRIX

\$1500 for their budget. The team therefore allotted a \$300 budget for the frame. Another common issue in quadrotors is vibration from the motors affecting flight. To avoid any vibration issues, the frame must provide vibration damping across the frame, as well as between the plane and the frame. It was decided to keep the design of the frame as simple as possible, to avoid any unforeseen complications. Finally, the team believed it would be an interesting possibility to make the attachment removable and interchangeable. This would open a new possibility for use on other aircrafts. Team 8 was able to come up with three preliminary designs, each having their own advantages and disadvantages.

1) *Design 1*: The first design of the attachment, seen in Figure 1, consists of two beams running parallel to the plane. They are attached to the front and back wings of the plane and provide a platform on which to mount the quadrotor motors. To attach the beams to the plane, a rod would be inserted into both the front and back wings, to provide support and an attachment point along the balsa wood wings. Vertical rods of two different lengths would go from the rods inside the wings to the parallel beams. They would offset the beams enough for clearance of the propellers. Two motors will be placed on each beam, creating a square of equal width and length. The symmetrical shape is important to keep the aircraft as stable as possible during vertical flight. This design requires little modification to the integrity of the plane. Also it is lightweight, aerodynamic, and has few parts. However, it will be difficult to insert and secure the rods in both wings. In addition, the design is very strong and hard to keep from moving and vibrating. The beams are vulnerable because they are not solidly attached to the wings because the wings are fragile.

2) *Design 2*: Design two of the quadrotor attachment is significantly different than the first. In the second design, the frame is attached directly to the bottom of the plane. The shape of the frame is also modified into a pentagon, with two crossbeams for attachment and support, seen in Figure 2. The motors will again form a square, equidistant from left to right as well as front to back. The frame allows a large attachment area, while staying strong. The frame also reduces the number of components. The frame is thought to be as simple and structurally sound as possible, while keeping clearance for the propellers of both the quadrotor and the front propeller of the plane. These potential benefits are countered by its multiple disadvantages. The frame is relatively large, and therefore will be heavier than other options. Unfortunately, the weight of the design can't be greatly reduced without suffering a loss in strength. Finally, the frame will need to be hard mounted to the plane, using screws or similar attachments which is undesirable because the plane should be kept intact.

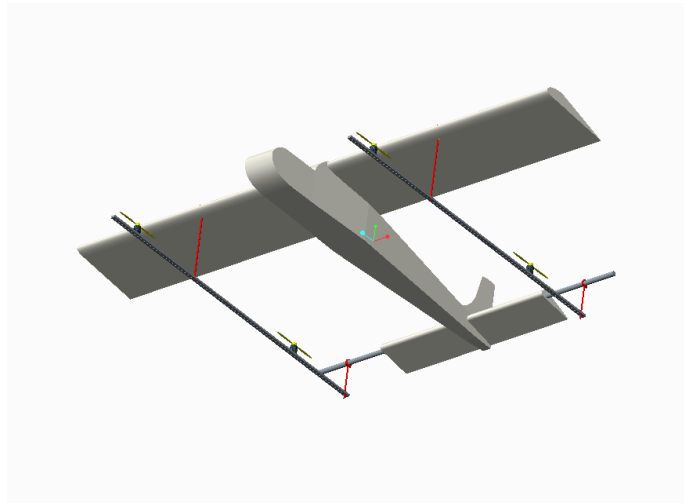

Fig. 1. Design Option 1

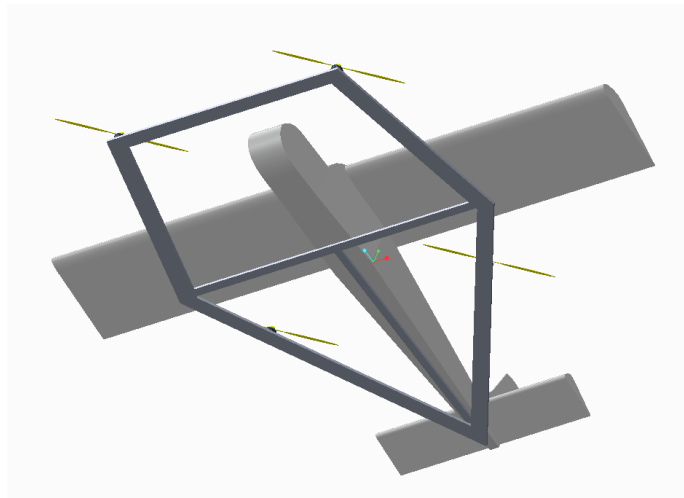

Fig. 2. Design Option 2

3) *Design 3*: Design three is somewhat of a compromise between all of the possibilities, seen in Figure 3. The frame is a modified H shape, with two cross beams supporting two beams parallel to the plane. The cross beams are attached to a lightweight base running across the width of the fuselage. The base is to be attached to the plane using high-strength Velcro. This is a simple solution that avoids major modification to the existing plane. The Velcro would also allow the attachment to be removable. Between the plane and the base, a sheet of quick recovery foam will be placed to dampen the vibration from the frame to the plane. The resulting frame would be lightweight, strong, removable, and vibration damping. The advantages of this design are directly related to the constraints of the frame attachment design. The design will not be as light as the first, but will still be lighter than the second design. Additionally, it is built to withstand the forces of the motors and the weight of the plane. The frame remains strong by selecting lightweight, but high strength materials. Vibration damping will be achieved using the quick recovery foam. Finally, the attachment designs simplicity is another advantage because it reduces problems occurred from machining. No modification to the original plane is necessary, making this an ideal design.

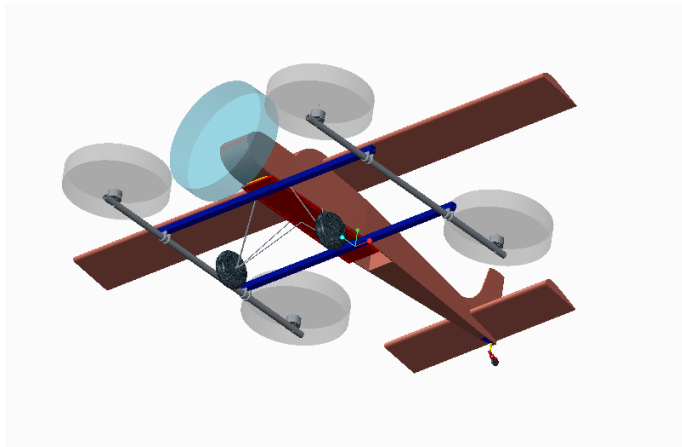

Fig. 3. Design Option 3

B. Selection

When selecting the optimum design for the frame attachment, the original constraints of the design needed to be considered for each. Each design had its own advantages and disadvantages, and when compared, the decision was simple. The first design is too structurally weak, and would not provide a solid base for the motors of the quad-rotor. Also, the design would require modification to the original plane, a difficult task that Team 8 would like to avoid. The second design would be stronger, however it would be very heavy and also require modification to the fuselage of the plane. From there, it was concluded that design three is the best option to create the best possible aircraft with VTOL capabilities. Table xx is a design decision matrix that compares the important components of each of the designs. Team 8 selected the most important factors for the base and weighed them for each design to come to a final conclusion on which design to use. Refer to Table II to see parameters and scores.

Component	Importance	Design 1	Design 2	Design 3
Cost	10	4	4	7
Build Time	8	4	4	6
Weight	8	7	6	5
Difficulty	5	4	4	6
Strength	5	4	7	7
Aerodynamics	5	6	4	4
Vibration	5	4	4	6
Variability	3	4	4	8
	Total	230	227	297

TABLE II
DESIGN OPTION DECISION MATRIX

IV. FINAL DESIGN

The final design was based on the design three concept discussed above. The result was a quadrotor attached to the bottom side of the Senior Telemaster plane. The quadrotor attachment began with a base, which two beams cross perpendicularly with respect to the fore-aft axis of the plane. Off of these beams ran another two arms which end with the quadrotor motors at each end. This created a symmetrical square of 100 cm between the motors. An overview of the quadrotor design can be seen in Figure 4 (A), and the final hybrid aircraft in Figure 4 (B). The design required extensive research, planning, and knowledge

of mechanical, electrical, and materials concepts. Each component of the system was chosen carefully in order to create the best possible system.

A. Mechanical Components

Team 8 began the component selection by selecting materials for the quadcopter frame. The most important aspects of the material selection were material strength, weight, and cost. This was to reduce the amount of weight the quadrotor and plane would need to lift, without sacrificing system strength. Additionally, the materials for the frame had to be low cost (Team 8 estimated less than \$300) due to the high cost of the remaining parts. As a result, the base of the quadrotor was made of 0.25 thick plywood. This was chosen for weight and simplicity, as Team 8 had the material on hand and was able to laser cut the material for fast fabrication. The base can be seen in Appendix A. Attached to this plywood was quick-recovery polycarbonate foam, used to cushion the contact as well as dampen vibration between the base and the plane. The foam is adhesive backed and was simply cut and placed to match the profile of the base. To attach the plane and the base, Team 8 used 2 wide industrial strength velcro, which was a simple solution that allowed for removal of the quadrotor and avoided any permanent damage to the plane. For the cross beams of the quadrotor, Team 8 chose square 1 hollow aluminum 6061 tube. These aluminum tubes were chosen because they were strong, while remaining relatively light and low cost, Again the aluminum tubes can be seen in Appendix A. Next, circular 0.5 hollow carbon fiber tubes were used as the arms of the quadrotor, these tubes are shown in Appendix A. Carbon fiber was chosen again due to its high strength and low weight properties. Additionally, carbon fiber dampens vibration, and too much vibration in the system can affect the stability of the quadrotor as well as the integrity of the system about the attachment of the quadrotor and plane. To connect the carbon fiber to the aluminum, Team 8 had to design custom clamps. The team used ABS plastic to create a sandwich-style clamp to secure the carbon fiber. The clamp used a press-fit pin to orient the carbon fiber about the aluminum. The clamps are shown in Appendix A. Finally, Team 8 chose to use G-10 garolite to create a two-piece motor mount in order to attach the motors to the carbon fiber, these mounts can be seen in Appendix A. The bottom motor mount was epoxied to the carbon fiber tube using Double Bubble Orange epoxy. The top motor mount was then bolted on the opposite side of the carbon fiber to again clamp around the tube. Team 8 calculated the total weight of the frame to be 2,750 g.

After selecting all of these materials, Team 8 verified the strength and reliability of the materials. This can be seen in Section IV-C2, Design for Reliability. Also, as stated above, all technical drawings can be found in Appendix A.

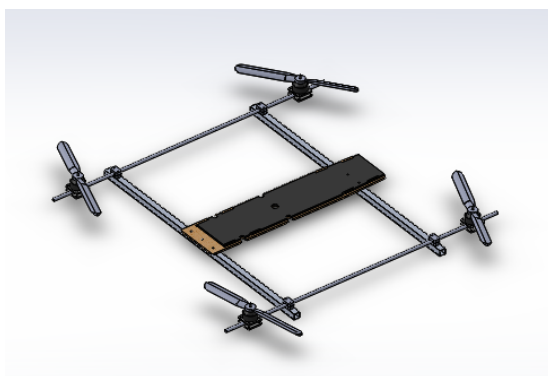

A: Quadrotor Attachment



B: Hybrid Aircraft

Fig. 4. (A) Quadrotor and (B) Hybrid Aircraft CAD Models

With the frame materials chosen, the next step was for Team 8 to find the correct motor and propeller combination needed to lift the hybrid aircraft. First, the overall weight of the system needed to be measured. This is composed of the plane weight and quadrotor weight, which includes an estimate for the motors and electrical system. The plane weight included everything needed to fly the plane in horizontal flight, and was measured as 5,488.6 g. The quadrotor weight was calculated as 2,750 g. The result was a final aircraft weighing 8,238.6 g. With the weight of the system, Team 8 then found the required thrust for each motor. The total weight was first divided among the four motors to be 2,059.6 g per motor. Next, a 2:1 Factor of Safety (FoS) was applied, for a final desired thrust per motor of 4,119.3 g. These calculations are compiled in Table III.

Weight of Plane	5488.6 g
Weight of Quad	2750 g
Total Weight	8238.6 g
Weight per Motor	2059.6 g
Desired Thrust	4119.3 g

TABLE III
THRUST PER MOTOR CALCULATIONS

Using the manufacturer’s specifications, the Cobra 4510 motors were selected. Cobra motors suggested using APC brand propellers. Team 8 found using APC 18 x 5.5 pitch propellers at 6,414 RPM, the Cobra motor was able to produce a thrust of 4,468 g. This value satisfies our desired thrust of 4,119.3 g. Team 8 decided that this calculation must be verified multiple ways because the entire system depended on its accuracy. To do so, Team 8 used eCalc and Static Thrust Calculator programs [16] and [17]. Both programs are used extensively by multirotor and model plane enthusiasts, and are widely accepted as the standard for model aircraft calculations. By entering the chosen system specifications into both programs, eCalc computed a thrust of 4,144 g at 6,643 RPM and Static Thrust Calculator computed a thrust of 5,560 g at 6,414 RPM, both over the desired thrust of 4,119.3 g. The Static Thrust Calculator results in a much higher thrust because it does not take into account many factors, and as a result calculates the highest achievable thrust for the motor in perfect conditions. The thrust calculations for the Cobra Multirotor Motors can be seen in Table IV.

Calculator	RPM	Thrust (g)
Manuf. Specs.	6414	4468
eCalc	6643	4144
Static Thrust	6414	5560

TABLE IV
THRUST CALCULATIONS

B. Electrical Components

For the hybrid quadrotor design, the 3DR APM 2.6 autopilot board was chosen as the navigation system because of its exceptional features. The software used in conjunction with the APM is Mission Planner, which is an open source software that can be easily modified. The APM 2.6 is capable of providing a fixed wing or multirotor aircraft with autonomous flight and GPS guided missions. To do this, the APM 2.6 has an off-board compass attached to the GPS unit. The offboard GPS helps reduce magnetic interference from the current that is flowing throughout the APM. Moreover, the APM includes a 3-axis gyroscope, 3-axis barometer, and 3-axis accelerometer that can be used for in flight stabilization.

To communicate with the APM 2.6, a 3DR Telemetry kit is necessary. The 3DR Telemetry kit allows two way radio communication between Mission Planner and the APM 2.6 board. The user can tune flight

parameters remotely, and download commands onto the APM 2.6 board via the telemetry set. In addition, the telemetry kit, along with Mission Planner, record real time flight data that can be saved and analyzed for later use. For manual flight, a PPM encoder (pulse position modulation) is used to map all RC channels from the receiver into a single input port on the APM 2.6 board. This feature reduces the probability of signal error and enables the APM 2.6 to operate more efficiently.

1) *Motor Details:* The Cobra 4510 multirotor motor was selected for Team 8s design because it would provide the design with longevity, reliable performance, and the required thrust. It has a strong 6 mm shaft with large ball bearing for support and durability. The stators have 0.2 mm lamination which reduces eddy current loss and increases operational efficiency. These motors come with a 330 mm pre-tinned motor lead for direct and dependable connection to ESCs. It is also possible to solder 3.5 mm bullet connectors onto the motor lead for detachable connection to the ESC.

2) *ESCs:* In this design, the Cobra 60A opto multirotor ESCs were chosen because of their compatibility with the Cobra 40A motors. The Cobra motors can operate at a maximum current rating of 40A. It was important to select ESCs that have higher current rating than the maximum current rating of the Cobra motors in order to prevent overheating or burning out the motors. The Cobra 60A opto multirotor ESCs comes with a pre installed firmware that can handle a refresh rate of 500 Hz from the APM 2.6 board. Also, the ESCs can send PWM signals to the motors at a rate of 8 KHz which is beneficial for the design. One aspect necessary of the ESCs was the ability to calibrate their response. These Cobra ESCs can be calibrated for smooth linear throttling which will help with the stabilization of the hybrid vehicle. In addition, an important safety factor of the ESCs is that they will not arm the motors if the throttle is not at its minimum value as well as if the temperature is at or above the maximum operating temperature to reduce the risk of failure. Since space is limited on the quadrotor, it is also beneficial that the ESCs use opto isolators to transmit signals via light. This will limit the amount of interference that the ESC would have on nearby electronics.

3) *Batteries:* The power in the design will be supplied by three 6S 22.2V 5000mAh LiPo Venom flight packs. Two of these batteries are connected in parallel to power the quad and one battery is used to power the planes motor. Lithium polymer (LiPo) batteries are lightweight and can handle more physical trauma than other types of batteries(1). The combination of the batteries being lightweight and having a high energy density per cell provides the design with the most desirable flight time The Cobra motors can generate a maximum thrust at 40A . Therefore, the design requires batteries that can output a minimum of 160 amps in short bursts. The Venom Flight packs have a burst C rating of 35 C or 175 amps. This burst rate will meet the demands of the Cobra motor at their maximum draw. Furthermore, the input voltage of the venom batteries exceeds the maximum voltage that can be regulated by the APM power module. Thus, a separate battery is used to power the APM 2.6. A NiMH 6V battery was inherited from last years team and wired to power the APM. It has a capacity of 2000 mAh and it is capable of powering the APM 2.6 board for more than the maximum allowable flight time of 40 minutes in the AUVSI student competition.

4) *Flight Time for Quadrotor:* The maximum allowable flight time for the quadrotor is calculated using the following assumptions and information. During testing, Team 8 obtain an ideal vertical takeoff speed of .5 meters per seconds .On average, the quadrotor will utilize 75% of its maximum throttle. Moreover, each quadrotor motor draws an average of 30 amps each and the entire system draws an average total current of 120 amps. The maximum depth of discharge (DoD) for the batteries is 80%. Using the Equation 1, Team 8 obtain a total flight time of 4 minutes.

$$\text{EQN 1. } \textit{FlightTime} = (0.8 * 60(\textit{mins}/\textit{hour}) * \textit{batteryCapacity}) / (\textit{totalCurrent})$$

Since the APM 2.6 board use its own separate battery , it is important to determine how long the NiMH battery pack can be used to power the board. Under normal operation, the APM 2.6 board draws a

maximum current of 2.25 amps and operate at 5.37 volts. Therefore, the APM 2.6 power output is equal to 12.0825 Wh. Meanwhile, the NIMH battery has a capacity of 2 amps and an open circuit voltage of 6 volts. Its calculated power output is 12 Wh and its maximum depth of discharge (DoD) for the battery is 80%. The maximum allowable operation time for the APM 2.6 board was computed using Equation 2, and is equal to 47.67 minutes.

$$\text{EQN 2. } APMTIME = (0.8 * 60(\text{mins}/\text{hour}) * \text{batteryOutput}) / (APMpower)$$

5) *Electrical Diagram:* The electrical components for the design were wired as shown in Figure 5. Two Venom flight pack batteries are connected in parallel with the cobra multirotor ESCs. An ESC is connected into each of the Cobra motors and each ESCs servo wire is connected into their corresponding output port on the APM 2.6 board. Peripherals such as the 3DR telemetry , GPS and Compass unit, and the APM power module are connected into their labeled ports on the board. A PPM jumper connects the signal pin of input port 2 and 3. The PPM encoder is connected to input port 1 of the APM. Lastly, 6 of the 8 ports on the PPM encoder are plugged into their corresponding port on the RC receiver.

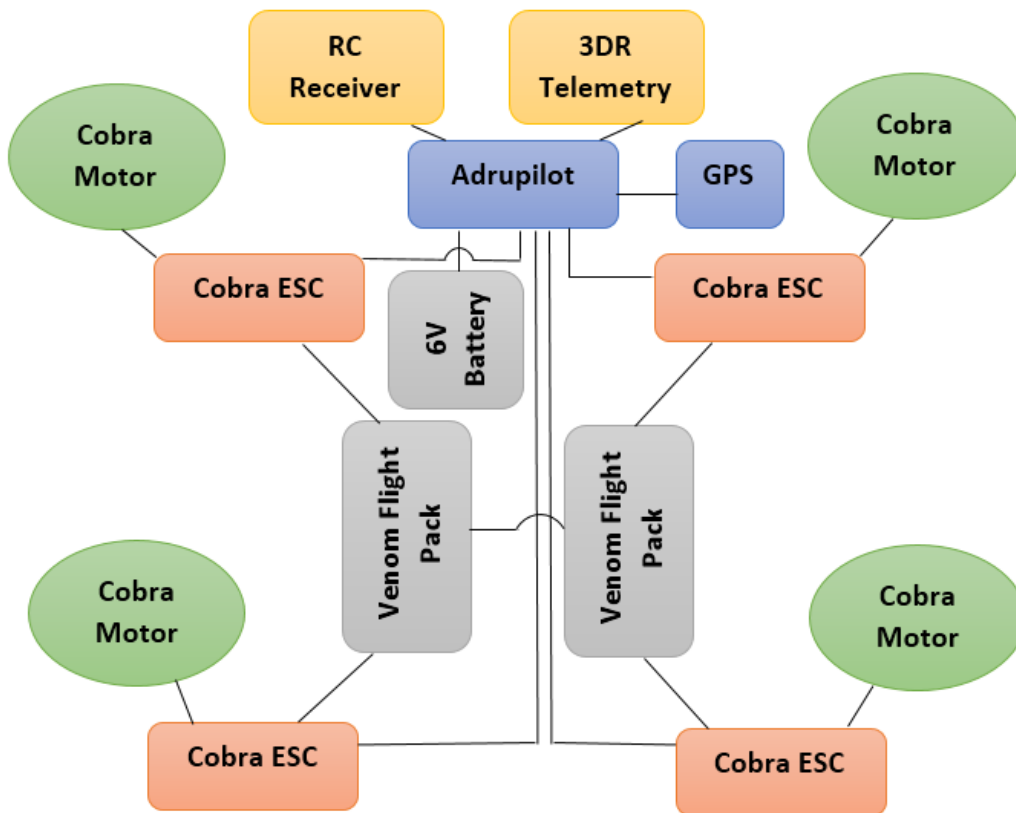

Fig. 5. Electrical System Diagram

C. Design for Manufacturing, Reliability, and Economics

Team 8's goal for the senior design project was to build an aircraft capable of vertical takeoff and landing. An important aspect to consider for the final aircraft design was manufacturing. Using proper design for manufacturing techniques, the cost and quality of the final product can be greatly improved.

These techniques include, but are not limited to: reducing the number of parts, use of standard components, ease of fabrication, and minimizing assembly steps [18]. Reliability is another important feature of the final design. The aircraft must be able to withstand not only the forces being applied to the system, but also frequent use. It is crucial to choose reliable components for the design. Finally, design for economics is a critical part of the final design. It is important to stay within budget while also creating a design that is comparable to other products on the market. Team 8 has designed an aircraft in which all of these aspects play a major role.

1) *Design for Manufacturing*: The first of the above design for manufacturing techniques is analyzing the total number of parts in the system. Our system can be separated into two subsections. The primary subsection is the Senior Telemaster plane. The plane will be treated as one part in our design, as it is pre-assembled for our project and is not being modified. This was very important to Team 8 as it insured the capabilities of the existing system and avoided any destructive modifications. Another reason to avoid any modifications to the plane is that successive senior design teams are expected to utilize the platform. The second subsection of the design is the multi rotor attachment. This subsection includes all new materials being added to the plane in order to achieve vertical takeoff and landing. The multi rotor attachment is comprised of the remaining parts listed in Table V.

It can be seen in Table V that the total number of parts in the final design is 46. Several steps could be taken to reduce this number, however with the given situation, Team 8 did an adequate job at keeping simplicity an important design factor. If provided a larger budget, many of the parts could be exchanged or customized. For example, customizing the base of the attachment could incorporate the cross beams and reduce assembly time, but due to budget and time constraints, cheap and readily available plywood was laser cut to fit the design. Ideally the design should have as few parts as possible to achieve a fully functioning design.

The second aspect considered in the final design was to use standard and available components. By

Part	Quantity
Plane	1
<i>Attachment Body Materials</i>	
Plywood Base	1
Polyurethane Foam Pad	1
Industrial Strength Velcro	4
Aluminum 6061 Cross Bars	2
Carbon Fiber Arms	2
ABS Arm Mount Bottom	4
ABS Arm Mount Top	4
G-10 Motor Mount Bottom	4
G-10 Motor Mount Top	4
<i>Quad Rotor Components</i>	
6V Battery	1
Venom 22.2V Battery	2
Cobra 60A ESC	4
Cobra Multi Rotor Motor	4
APC Propeller 18x5.5"	4
Adrupilot APM 2.6 and GPS	1
3DR Telemetry Kit	1
Futaba R/C Receiver	1
Wiring	1
Hardware	n/a
Total Number of Parts	46

TABLE V
TOTAL PARTS LIST AND QUANTITIES.

using standard components; complexity, cost, and assembly time are all decreased while repeatability is increased. For the quad rotor attachment, Team 8 chose to use as many standard components as possible. These include plywood for the base, standard 6061 aluminum, protruded carbon fiber, hardware and other parts readily available from local hardware stores or material suppliers. The non-standard components were crucial to the design and kept to a minimum. These components include the motors, propellers, battery packs, autopilot system, and a few others. While these parts are not available locally, they were delivered quickly and easily. Without these non-standard components, the resulting design would not work effectively.

Another important aspect is to keep fabrication simple and to a minimum. For the final design, there are several components that require fabrication, but this fabrication is extremely simple. The plywood base was laser cut due to speed and ease, but could have also been fabricated by hand. The aluminum cross bars only required trimming and several holes drilled in them for attachment of other pieces. This fabrication can be done quickly as well. Next, the carbon fiber arms only required two small holes in each, for positioning purposes. These arms are held in place by two piece ABS plastic clamps. These clamps are fabricated with a combination of four holes and one final cut to separate the two halves. Finally the motor mounts are cut into a square shape with four holes in the bottom mount and five holes in the top mount. All of these parts can be found in Appendix A, with their corresponding drawings. This ease of fabrication requires less time and effort to produce the correct parts. In addition, it leaves less room for fabrication error, which can propagate into error in the final design.

Finally, Team 8 focused on minimizing assembly steps and difficulty. This concept follows the same as all of the others previously mentioned. By reducing difficulty in each step, the overall design is simplified. The final design is comprised of several steps, but most will be done by the end consumer, these are detailed in Team 8's Operation Manual. An overview exploded view of the assembly can be seen in Figure 6. The first of these consumer steps is attaching the base and aluminum cross beams using six 1/4-20 bolts, washers, and lock nuts. Once the aluminum cross beams are secured, the adhesive-backed foam pad is stuck on to the top of the base. After that, the ABS plastic clamps are attached to the aluminum beam ends. Clamped on the ends are the carbon fiber rods, perpendicular to the aluminum beams. An exploded view of the clamps and arms can be seen in Figure 7.

One step that must be done by the manufacturer is epoxying the bottom motor mounts to the carbon fiber rods. The mounts must be a distance of 100 cm center-to-center, as well as being centered about the long axis of the carbon fiber rod. To do so, a template was made and secured to a level surface. An

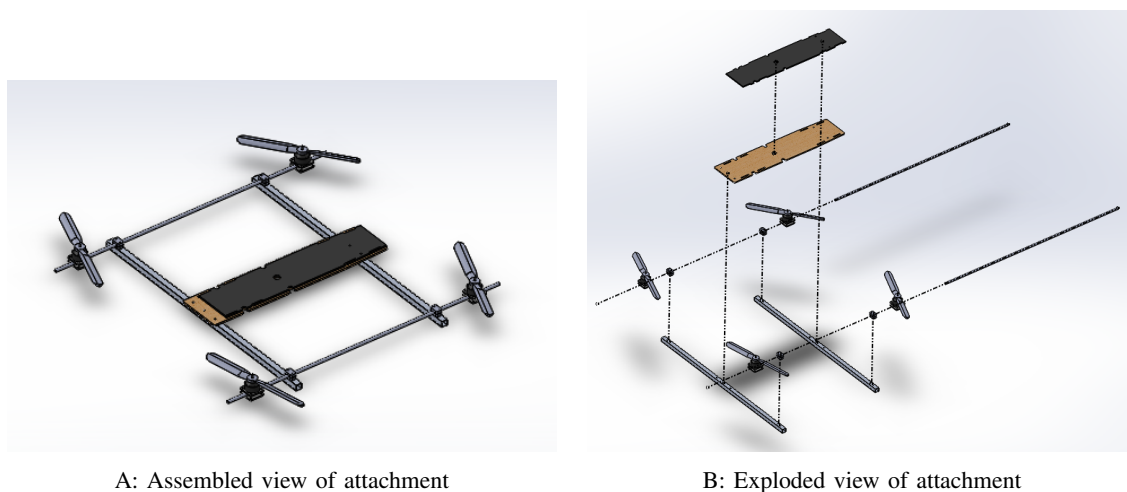
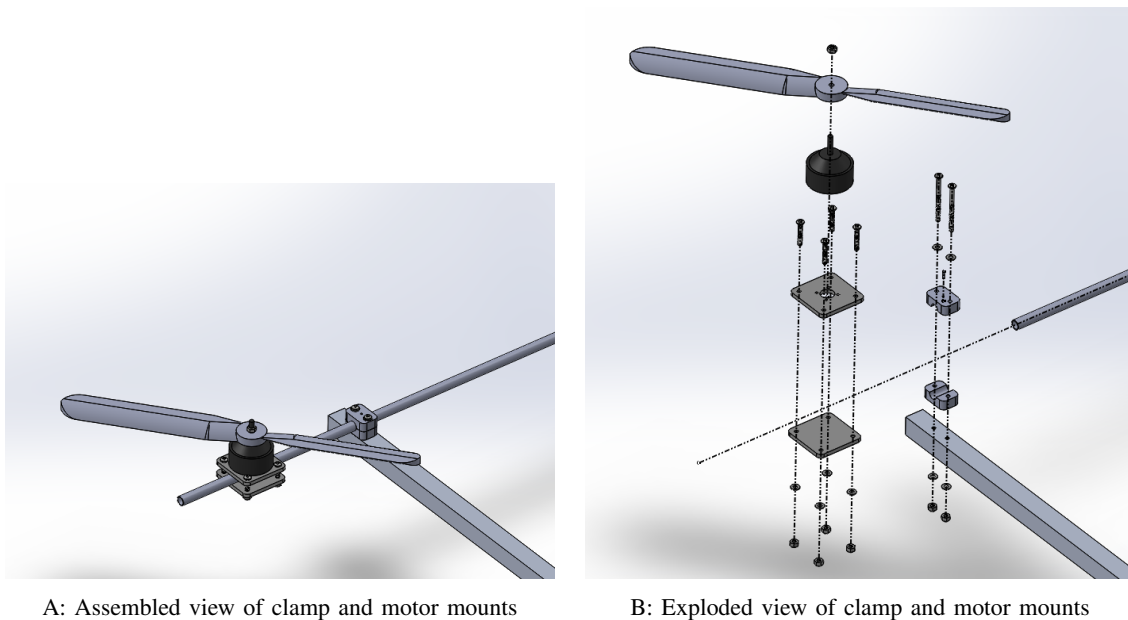

Fig. 6. Attachment assembled (A) and exploded (B) views to show how major pieces are assembled.



A: Assembled view of clamp and motor mounts

B: Exploded view of clamp and motor mounts

Fig. 7. Clamp and motor mounts assembled (A) and exploded (B) to show how parts are assembled.

example of the template can be seen in Figure 8. This provides an outline of where to temporarily secure the two mounts using a removable adhesive (tape). Once the mounts are secured, high-strength epoxy (Team 8 used Double Bubble Orange Epoxy) can be applied to the area in which the carbon rods will rest on the mounts. This is the highlighted rectangular area in Figure 8. After the epoxy is applied, the carbon fiber rod should be placed on the mounts according to the template, it is important to keep the rod centered about the mounts. Next, the assembler should weigh down the rod and let the epoxy cure (the Double Bubble Orange Epoxy had a cure time of twelve hours). This process is repeated for the second carbon fiber rod. The result is a simple way to insure the level attachment of the bottom mounts. The level attachment of the motors can be further adjusted in a later step.

The four motors can be attached to the four top motor mounts using the M3 screws provided. These mounts are then attached to the bottom motor mounts that were epoxied to the carbon fiber rods. The top mount is bolted to the bottom mount, but is placed on the other side of the carbon fiber rod, compressing around the rod. The mounts use size 10-24 bolts, washers, and lock nuts at each corner. The motor mount

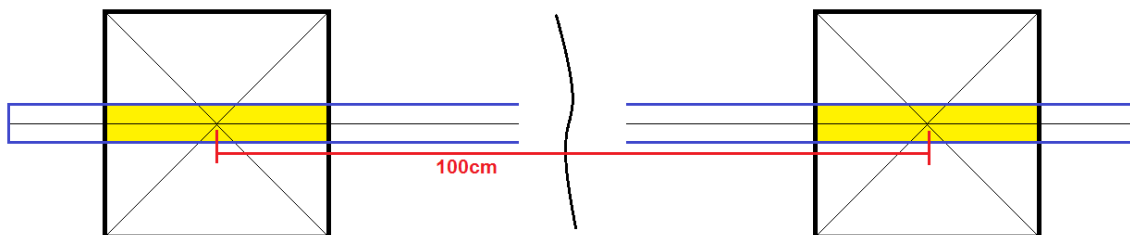

Fig. 8. An example template used to align and epoxy the motor mount bottoms to the carbon fiber rods. The centers of the mounts should be 100 cm apart.

Max Current (A)	Max Power (W)	Battery	Volts (V)
40	900	6 Cell	22.2

TABLE VI
ADDITIONAL MOTOR SPECIFICATIONS FOR COBRA 4510 BRUSHLESS DC MOTOR.

assembly can be seen in the exploded view in Figure 7. These four bolts can be adjusted to ensure the motor is attached level to the plane, as previously discussed.

The basic wiring of the aircraft needs to be done by the manufacturer. The process consists of supplying power to the motors and control to the ESCs. First, solder 3 mm male bullet connectors to all wires coming from motors. Next, solder 3 mm female bullet connectors to all ESC wires that will connect to the motors. These can then be connected safely. After the motors and ESCs have been connected, create a wiring harness by connecting two batteries in parallel. The wiring harness combines the two batteries in parallel, and can then be attached to the four ESCs. As a result, the motors are plugged into the ESCs, then ESCs are plugged into the wiring harness, which is then attached to the two batteries. Finally, the signal wire from ESCs are connected to the AduPilot, this allows the AduPilot to control the ESCs and in turn the motors.

In conclusion, the final design takes about 3 hours to assemble, not including the cure time for the motor mount epoxy. More detailed and clear instructions can be found in Team 8s Operational Manual, and all part drawings can be found in Appendix A. Team 8s final design took into account many aspects of design for manufacturing in order to promote simplicity, accuracy, and consistency.

2) *Design for Reliability*: To examine the reliability of the hybrid aircraft, many different components need to be considered. This includes the multi rotor motors, ESCs, carbon fiber tubes, aluminum beams, and the wood frame base. Each part has a different life cycle and different determining factors. The length of each part's life cycle will govern when it needs to be replaced in order to avoid overall system failure. It is important to analyze the failure modes of each part, the factors that caused the failure, and the effect of the failure on the system. To organize these failures and rate their severity; a Failure Mode, Effects, and Analysis (FMEA) was created and can be seen in Appendix B. In the FMEA, a failure would be considered a high risk if the Risk Priority Number (RPN) was over 100. As seen in the FMEA, there were three failure modes that were identified as high risk. The three failures were the large shear stress in the G-10 motor mounts, the vibrations in the wood base, and the large moments that could be created in the frame. Recommended actions have been assigned to address the issues and lower the RPN to acceptable values. These actions are currently being addressed by Team 8. Along with the three failure modes above, a recommended action was assigned to flying the plane in horizontal flight, even though the RPN was less than 100. This was because Team 8 decided this was of high importance, since only authorized pilots are legally allowed to fly the plane. The FMEA helped identify the risks involved in the system and work on correcting them before a problem occurred. In addition to the FMEA, Team 8 has done further analysis on the system.

The hybrid attachment design, uses four Cobra 4510 420Kv brushless DC motors. These are used to provide vertical lift to the aircraft. The motors are rated to withstand up to 900 W for maximum power input. Pairing this with APC 18x5.5 propellers at 84% throttle, the motors will draw 832.3W of power [22]. In this range of power, the manufacturer recommends that the motors be run at short burst of up to 15 seconds. This will keep the motors from overheating or burning out. Team 8 can monitor power delivered to the motors using the Mission Planner software to ensure the power limitation is not exceeded for longer than 15 seconds during the vertical takeoff and landing. By limiting large power usage, Team 8 is able to extend the life of the motors. This will be an important factor in increasing the life cycle of the motors. More specifications for the motor can be seen in Table VI.

Other components that need to be taken into account are the raw materials used to build the base of

the attachment. This includes 1/2 inch carbon fiber rods, aluminum 6061 1 inch hollow square beams, and the plywood base. All of these components will experience loads when the vehicle is in flight. The aluminum beams have an ultimate tensile strength of 45 ksi [19]. Since this is much larger than any thrust force applied, it was obvious the beams would not fail. From there, Team 8 needed to be determine how far the beams would deflect. The maximum displacement of the aluminum beams can be seen in Figure 9. This is using the maximum thrust force (49 N) created from the motors placed 100 cm apart from each other, where the carbon fiber rods will attach. From the Finite Element Analysis (FEA), it can be seen that the maximum displacement is 0.2026 cm. This amount of deflection is considered acceptable for our design and will not cause failure in our system.

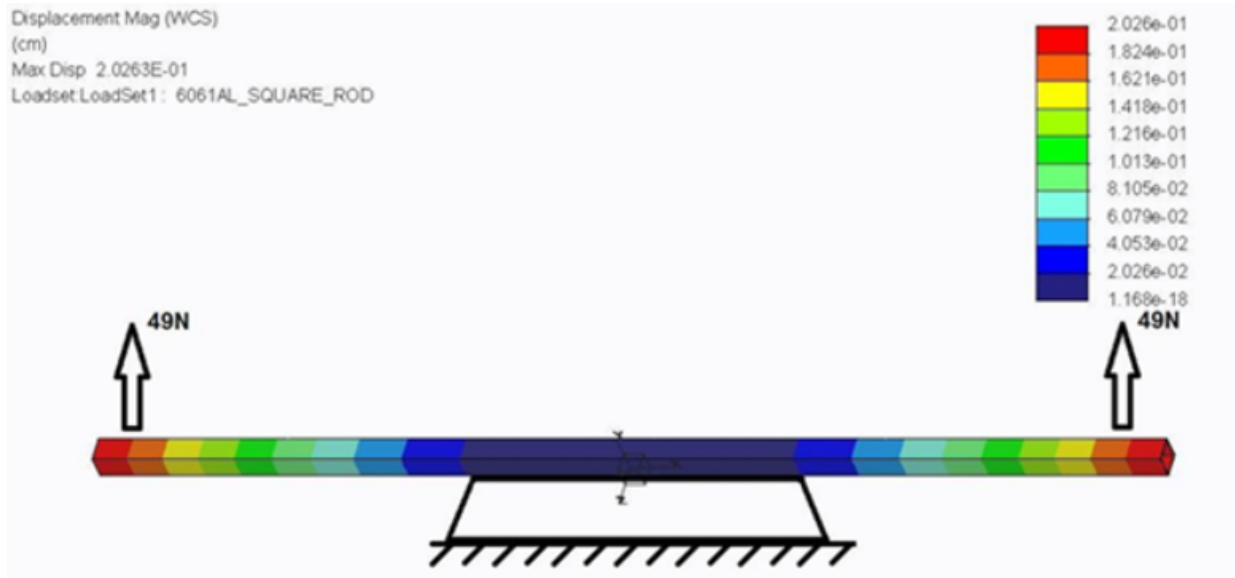

Fig. 9. Finite Element Analysis (FEA) conducted on the aluminum 6061 cross beams. A force of 49N, the maximum resulting force from the motors, was applied 50cm from the center in each direction. The result was a maximum deflection of 0.2026cm.

Another concern that can affect the reliability of the hybrid design is fatigue in the aluminum beams or the carbon fiber rods. For the aluminum beams, the fatigue strength is 14 ksi after 500 million cycles [21]. Therefore, fatigue in the aluminum rods is not a concern because of the relatively low stresses applied compared to the fatigue strength of the material. The mechanical properties of the other materials can be seen in Table VII.

Material	Ultimate Tensile Strength (ksi)	Ultimate Flexural Strength (ksi)	Fatigue Strength (ksi)
Aluminum 6061	45	40	14 @ 5×10^8 cycles
Carbon Fiber	120	89 - 174	n/a
Plywood	4.5	n/a	0.363 @ 10^6 cycles

TABLE VII
VARIOUS MATERIAL MECHANICAL PROPERTIES.

The carbon fiber rods fatigue strength also needs to be considered for the extended use over time. Carbon fiber fatigue limits and strengths are not readily available like other materials (steel, aluminum, etc.), so to ensure long life for the components, strength needs to be much larger than applied forces. For the selected carbon fiber rods, they have a flexural strength between 89 ksi and 174 ksi [20]. This is significantly larger than the applied load of around 100 psi or 0.100 ksi. For these reasons, fatigue will not be a concern in the carbon fiber rods.

With these factors considered, the hybrid aircraft attachment can last about as long as the operator desires during normal operation. Normal operation is defined as flight within motor limits, without any catastrophic crash. A catastrophic crash would be any kind of crash landing from high altitudes that causes damage to multiple components. This is the main concern for failure in the system. Without crashing, during normal operation, the attachment will maintain all of its capabilities.

3) *Design for Economics:* To achieve success in this years senior design project, Team 8 was allocated a budget of \$1,500. The budget is supplied by the Aero-Propulsion, Mechatronic, and Energy (AME) building funds at Florida State University, in conjunction with the Fund for the Improvement of Postsecondary Education (FIPSE). The overall goal of this project was to create the best possible aircraft for the future success at the 2016 AUVSI SUAS design competition. With this goal in mind, the funds were used to purchase necessary new parts and to replace many damaged parts from previous projects. These parts were used to modify the existing Senior Telemaster plane into a hybrid vertical takeoff and landing aircraft. All of the required parts needed to redesign and achieve this years goal have been purchased and shipped, leaving Team 9 with an excess of \$11.91. Team 8 was able to stay under budget. This was accomplished by planning which parts were needed, comparing cost to find the best price, and lastly, setting aside a percentage of the funds that would be used to replace previously damaged components. Using this approach, Team 8 was also able to purchase extra parts in case damage was caused to the exposed parts of the aircraft. These extra parts included two extra multi rotor propellers, an extra aluminum beam, and an extra carbon fiber rod. A breakdown of the cost of each component purchased by Team 8 along with the quantity for each part can be seen in Table VIII. The total cost spent on parts for this project totaled \$1488.09. The budget breakdown is shown in the pie chart in Figure 10.

With the cost of each component defined in pie chart above, it can be seen that 50% of the total budget was spent on the four cobra motors, four ESCs, and the APM 2.6 Adrupilot. The four Cobra 4510 DC motors were the most expensive parts that were purchased. While being budget conscious and comparing other motors, the Cobra 4510 DC motors provided the required thrust needed for aircraft at the most reasonable price. A comparison of similar products on the market will be displayed in Figure 11. Team 8 was focused on using the budget wisely and being cost efficient. Purchasing a new Adrupilot and 3DR Telemetry Kit was not in Team 8s original budget plans, but needed to be done after discovering that the Adrupilot APM 2.5 and 3DR Telemetry Kit from last year were both damaged and not working properly

Part	Qty.	Unit Price	Subtotal
Carbon Fiber 0.5" Arms	3	\$41.05	\$123.15
Industrial Strength Velcro	1	\$30.39	\$30.39
Double Bubble Orange Epoxy	1	\$11.99	\$11.99
APM 2.6 Adrupilot	1	\$239.98	\$239.98
12 AWG Silicon Wire	16	\$2.74	\$43.78
12 AWG Silicon Wire for ESC	1	\$10.04	\$10.04
12 AWG Male Wire Connectors	1	\$10.58	\$10.58
12 AWG Female Wire Connectors	1	\$8.92	\$8.92
Cobra 4510 420Kv Multirotor Motor	4	\$74.99	\$309.96
Cobra 60A Multirotor ESC	4	\$48.86	\$195.46
Venom 22.2V LiPo Battery	1	\$119.99	\$119.99
APC 18x5.5" Propellers	6	\$12.83	\$76.98
Resilient Foam Base	1	\$40.44	\$40.44
Aluminum 1x1" Beams	3	\$28.57	\$85.71
3DR Telemetry Kit	1	\$110.36	\$110.36
Hardware & Misc.	1	\$70.36	\$70.36
		Total	\$1488.09

TABLE VIII
LIST OF EXPENSES FOR EACH PURCHASED PART AND THE CORRESPONDING COST.

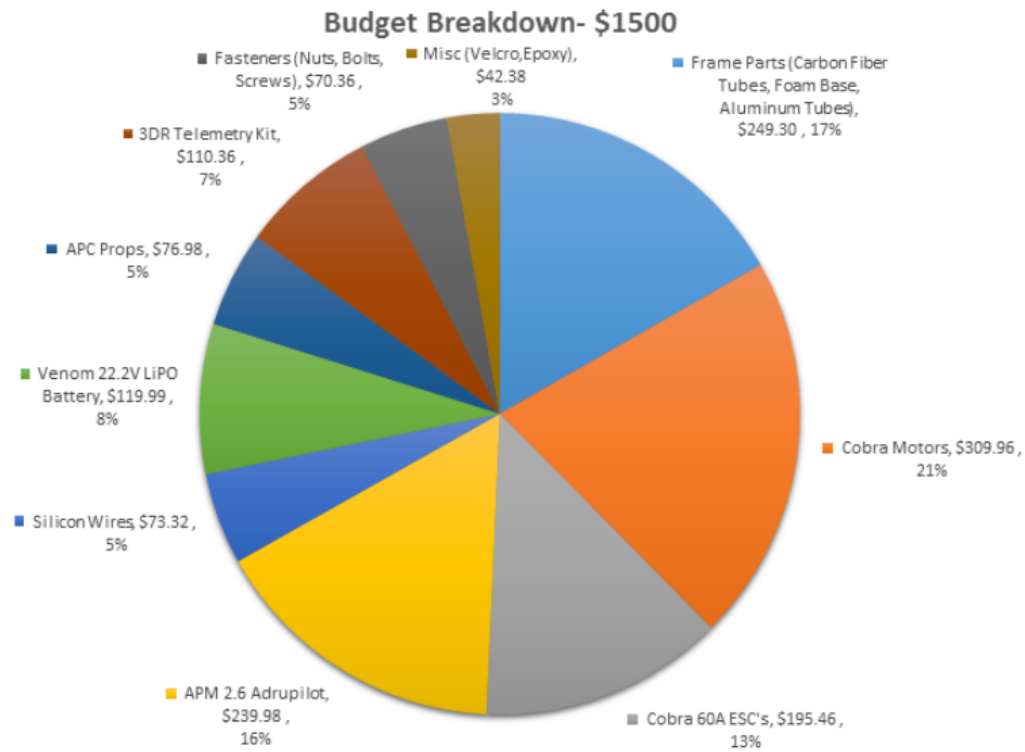

Fig. 10. Breakdown of expenses along with percentage of total \$1500 budget.

[23]. Overall, purchasing all of the necessary parts will prepare next years team to focus on completing the objectives of the design competition, instead of the design and build for the newly remodeled hybrid aircraft.

Team 8's aircraft was first designed and built last year as only a fixed wing aircraft. Since redesigning as a hybrid VTOL aircraft, comparing the cost of the aircraft to other fixed wing or multi rotor aircraft has become unrevealing. Instead, in Figure 11, the most expensive components that were purchased using the allocated budget have been compared to similar products on the market. Looking at autopilot systems which allows the multi rotor to become autonomous, the purchased APM 2.6 Aduropilot at \$239.98 was compared to another product on the market called the Pixhawk at \$319.98 allowed us to save \$80.00 [23]. In relation to the four DC motors that were needed, going with the Cobra 4510 420kV at \$74.99 per motor compared to a similar Tiger motor MN4120 at \$129.90 per motor allowed Team 8 to save \$219.64 [24]. Lastly, four ESCs were needed, and the purchased Cobra 60A ESC at \$48.86 per ESC in comparison to an on the market T-motor 60A ESC at \$59.99, saved Team \$44.52 [25]. To summarize, 50% of Team 8s budget was spent on four motors, four ESCs, and an autopilot system that totaled \$745.40. Similar on the market products of the four motors, four ESCs, and an autopilot system totaled \$1089.56. Thus, Team 8 saved \$344.16 by researching which components were needed for the success of the aircraft and what was the best possible price.

Team 8 has designed a multi rotor attachment for the Senior Telemaster plane inherited from previous senior design groups. With this aircraft, Team 8 was careful to create a design that not only met their objectives, but also kept in mind design for manufacturing, reliability and economics practices. The final design was as simple as possible without substituting quality. Team 8 was able to keep the complexity and amount of parts to a minimum, while also avoiding difficult assembly. The components chosen for the design were robust, ensuring strength and a long lifetime of the system. Also, cost was a major factor in

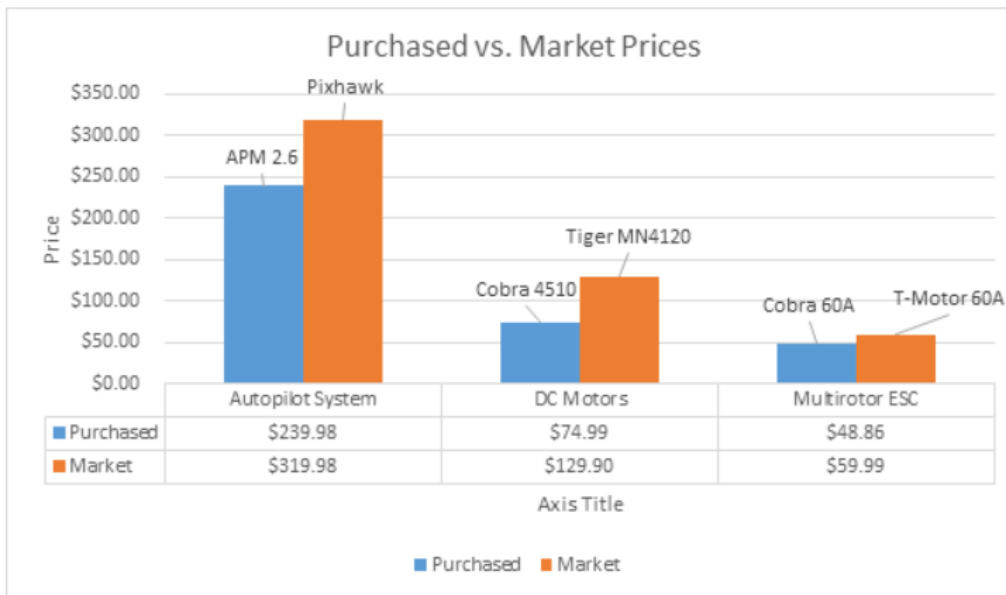

Fig. 11. Cost comparison of purchased components with similar products.

finalizing the design. Team 8 was able to stay under budget throughout the project. The design effectively uses simple, inexpensive, but strong components to create a final product capable of vertical takeoff and landing.

D. Operation Manual

The quad rotor attachment will work by exhibiting characteristics of both multirotor flight and fixed wing flight. The capabilities associated with fixed wing and multirotor flight are different. Fixed wing planes have longer flight endurance but must maintain forward flight to generate lift. A multi-rotor is capable of stationary hovering but it has a limited flight time because it has to power multiple motors to sustain flight. By being able to integrate favorable characteristics of both vehicles into a single unmanned aerial vehicle, it will have distinct advantages over other aerial vehicles.

This report will describe the operation of the quadcopter attachment that can be attached to an existing RC plane. The quadcopter attachment was designed to meet all rules and regulations of the annual Unmanned Vehicle System International (AUVSI) competition. The operation of the components such as the DC motors, APM, and radio controller are explained below to allow the operator to operate the vehicle in a safe manner. Enjoy and fly safely!

1) *Functional Analysis:* The function of this project is to create a Vertical Takeoff and Landing (VTOL) aircraft that can compete in the 2016 AUVSI design competition. This will be done by adding a quadrotor attachment to the already existing Senior Telemaster R/C plane. Adding the VTOL function will give the future team a leg up on the competition with an innovative design.

With this in mind, Team 8's project was to design an attachment to an existing R/C plane so it could have VTOL capabilities. To do this, the existing Senior Telemaster plane needed to be retrofitted with a quad rotor attachment that could give the plane vertical takeoff and landing capabilities. With the designed quad rotor attachment, the plane would have the ability to take off and land vertically.

The quad rotor attachment will work like a simple quad rotor vehicle that needs to be able to lift an R/C plane. This is done by matching four DC motors with four props to give the quad rotor enough thrust to be able to handle the weight of the plane. The desired thrust to weight ratio is 2:1 to ensure that the quad rotor can lift the plane and still have maneuverability. This thrust minimum is exceeded with the

selected props and rotors used for the design.

One of the harder aspect of this project is the stability of the hybrid vehicle. The vehicle will be stabilized by using an on board APM which has a built in accelerometer and gyroscope. The APM uses a proportional integral derivative (PID) controller to take the feedback from the accelerometer and gyroscope to stabilize the vehicle. With this APM, the plane will be able to stabilize by altering different parameters of the PID controller to control the stability of the vehicle. When stabilized, the plane will be able to achieve VTOL, which will be the extent of this operation manual.

2) *Project/Product Specification: Material Selection for Quadrotor and Control System: See Table IX, X, and XI*

Part	Quantity
Plane	1
<i>Attachment Body Materials</i>	
Plywood Base	1
Polyurethane Foam Pad	1
Industrial Strength Velcro	4
Aluminum 6061 Cross Bars	2
Carbon Fiber Arms	2
ABS Arm Mount Bottom	4
ABS Arm Mount Top	4
G-10 Motor Mount Bottom	4
G-10 Motor Mount Top	4
<i>Quad Rotor Components</i>	
6V Battery	1
Venom 22.2V Battery	2
Cobra 60A ESC	4
Cobra Multi Rotor Motor	4
APC Propeller 18x5.5"	4
Ardupilot APM 2.6 and GPS	1
3DR Telemetry Kit	1
Futaba R/C Receiver	1
Wiring	1
Hardware	n/a
Total Number of Parts	46

TABLE IX
TOTAL PARTS LIST AND QUANTITIES.

<i>Motor Specifications</i>							
Prop	Size	Lipo Cells	Voltage	Amps	Watts	RPM	Thrust
APC	18x5.5	6	22.2V	38.76	860.5	6414	4468

TABLE X
MOTOR DATA SHEETS.

<i>ESC Specifications</i>				
Max Count. Current	Max Burst Current	Operating Range	Number of LiPo cells	BEC Output
60 Amps	70 Amps	8 to 25 Volts	2 to 6 cells	None (opto)

TABLE XI
ESC DATA SHEETS.

<i>Battery Specifications</i>					
Charge Rate	Max Volt/Cell	Max Pack Voltage	Min Discharge Volts	Continuous Discharge	Max Burst Rate
5A (1C)	4.2V	25.2V	18V	25C	35C

TABLE XII
BATTERY DATA SHEETS.

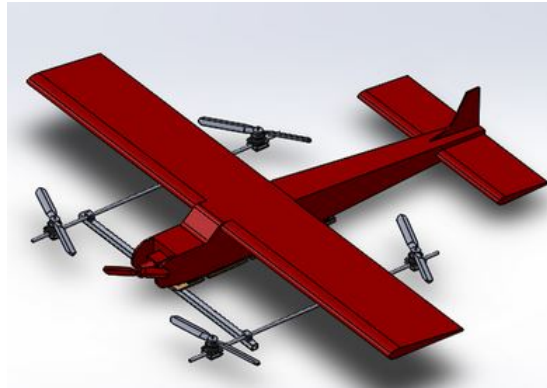

Fig. 12. Placement of Quadrotor Frame Attachment in reference to plane.

3) *Quadrotor Frame Assembly*: This operation manual will give directions on how to assemble the frame to an existing Senior Telemaster R/C plane, however the directions can be applied to any R/C plane, with dimensions that fit within the constraints of the frame.

Base Assembly:

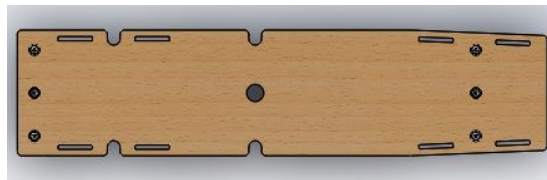

Fig. 13. The frames base plate.

Plywood Base joins to 6061 Aluminum Cross Beams:

- Ensure that the two pairs of tri-series holes from base assembly align with the holes drilled in both aluminum rods.
- Once both rods are aligned, ensure that rods are positioned so that the holes on either side (where the motor clamps attach) are face up.
- Use 6 1/4"-20 screws, washers, and lock nuts to secure front and rear rod to the base assembly, Figure 14
- Machine and assemble the aircraft for testing
- Test and troubleshoot the system so that autonomous VTOL is achieved

Quick-Recovery Polyurethane Foam:

Used to ensure bottom of Telemaster R/C Plane is not damaged by the hard plywood base or screw heads that protrude from the base. Also the foam will dampen vibrations.

- Before exposing adhesive, ensure padding slots align with slots cut into plywood base.
- Once aligned, use pencil to trace the edge to use as a reference to align pad when sticking to plywood, (step d).

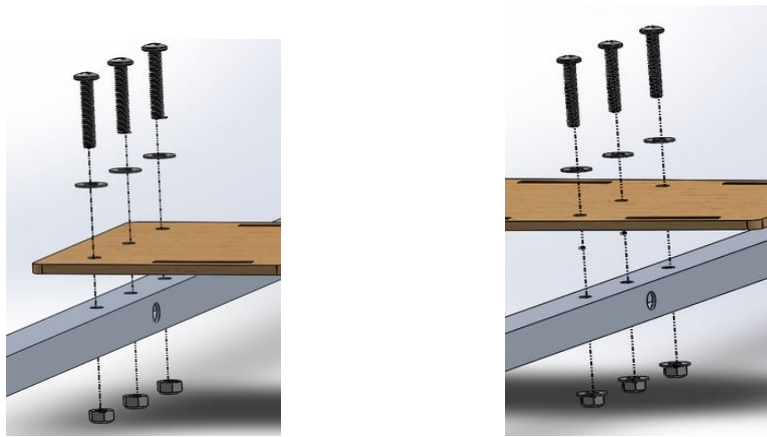

A: Assembled view of clamp and motor mounts B: Exploded view of clamp and motor mounts

Fig. 14. Aluminum 6061 rods are attached to the front (A) and rear(B) of the base plate.

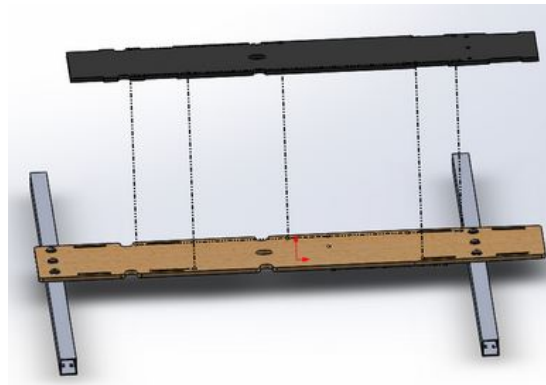

Fig. 15. Foam padding must be properly aligned and placed over the plywood base to minimize the risk of damaging the R/C plane.

- To attach pad onto base, user must first peel plastic layer to expose adhesive.
- Align the padding to reference line similar to what you did in step b.
- When aligned, slowly roll pad across plywood surface to ensure that no air bubbles are trapped between the two layers.
- Allow adhesive to stick for five minutes before continuing.

Carbon Fiber Tubes with Clamps:

- At this point the assembly of the ply wood base and aluminum 6061 should be complete.
- The clamps comes in two pieces; a bottom and top piece, which clamp around the carbon fiber rod and attach to the square aluminum rod. A pin has been supplied to ensure alignment of carbon fiber rod.
- Place carbon fiber rod, Figure 16, into the bottom clamp piece so that the carbon fiber tubes is supported on both sides by the clamps, Figure 16. Ensure that the pin in the top clamp aligns with the hole drilled into the carbon fiber tube.
- Motor mounts should be oriented so that they are under the carbon tubes.
- Place the top clamp piece over the the carbon fiber rod and slide the screws into the outer holes.
- Repeat steps until all clamps are on and then use 10-24x2 1/4" screws, washers, and lock nuts to secure the clamps.

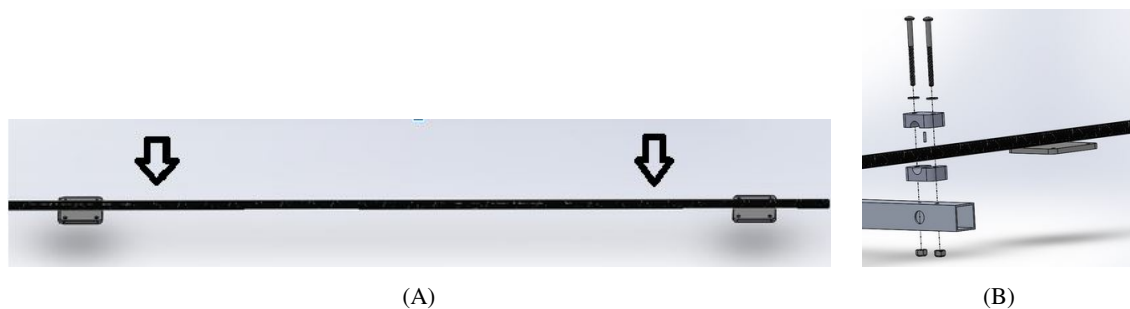

Fig. 16. Carbon fiber tubes, (A), are placed between the top and bottom pieces of the clamp assembly, (B). A pin on the clamp's top piece will hold it in a vertical orientation.

h

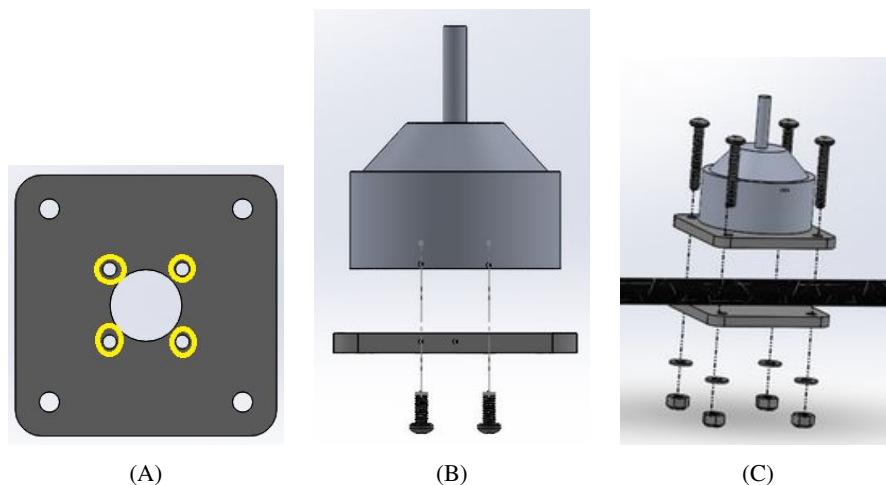

Fig. 17. The base plate has four holes, (A), for screws that will attach the motor to its base, (B). Once they are attached the motor base can then be attached with screws to the mounts on the carbon fiber tube, (C).

Cobra 4510 420KV, G-10 Garolite Motor Mounts, and G-10 Garolite Motor Base:
 Motor Mount to Carbon Fiber Rod:

- Align the four small holes, in Figure??, on the bottom of the motor with the inner holes on the motor mounts.
- Use four M3 screws to secure the motor and mount together securely, Figure , ??,. Be careful not to over tighten screws.
- Once motor is attached, align four outer holes on the motor mount with the four outer holes on the G-10 motor base which is attached to the carbon fiber rods, Figure ??.
- Use the 10-24x1.5" screws, washers, and lock nuts to tighten the four corners evenly to maintain proper orientation.

Industrial Strength Velcro:

- With steps 1-5 completed, take the plane and place it on top of the frame base.
- With plane in position, feed the Velcro straps through the holes on the base and fold the Velcro over the plane.
- Fold other half over the strip and tighten.
- Repeat a-c until all straps are secure.

APC 18" x 5.5" CW/CCW props:

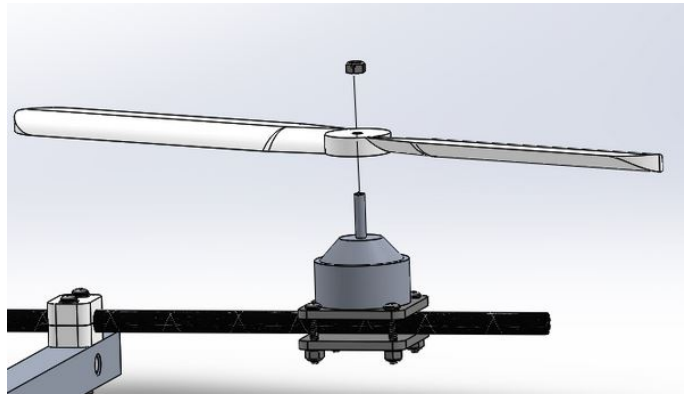

Fig. 18. The propeller is placed on the protrusion on top of the motor and then secured to the motor with the motor's provided screws.

- The front right propeller should be counterclockwise, and the back right propeller should be clockwise.
- The back left propeller should be counterclockwise, and the front left propeller should be clockwise.
- The propellers should be attached to the motors using the nut and washers provided with the motors. See Figure , 18,.

4) *Electrical Component Assembly:* RC Transmitter and Receiver:

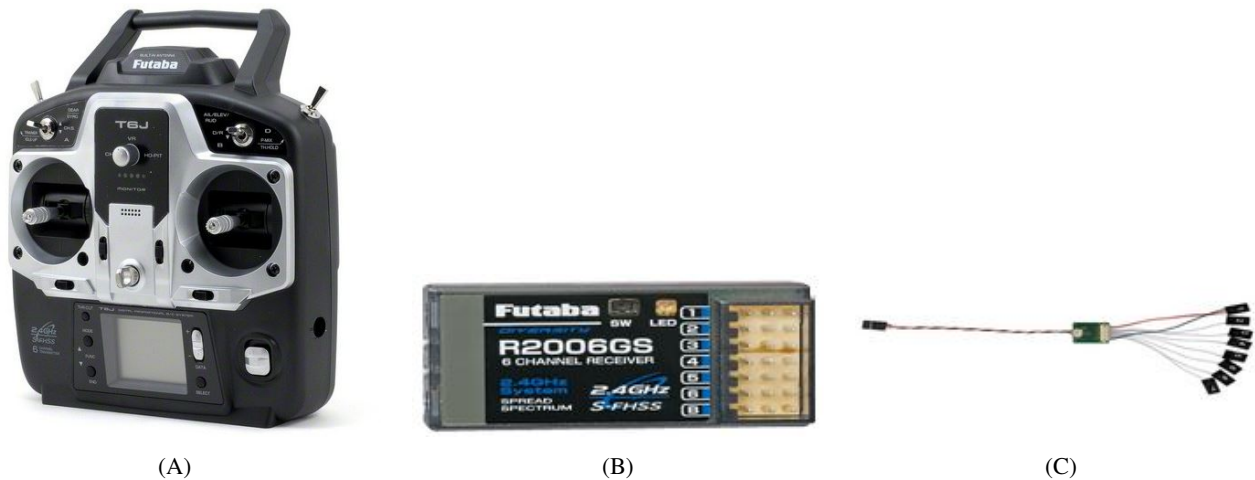

Fig. 19. Futaba T6J 6-Channel Transmitter, (A), communicates with Futaba R2006GS 6 channel receiver (B). Output cables, (C), are placed into receiver to connect to APM port.

The hybrid multirotor airplane system utilizes the Futaba T6J 6-channel transmitter and the Futaba R2006GS 6 channel receiver for manual flight. It is important that every pilot to understand how to operate the transmitter before flying the aircraft. Please visit the following link for detailed explanation on how to utilize the transmitter. [?]

Batteries:

It is necessary for the user to prepare the batteries before connecting them to the system. Primarily, the system utilizes three Venom 25C 5Ah 22.2V LiPo batteries to power the aircraft. Two of which are connected in parallel for powering the quad-rotor motors and the last one is to power the front motor of the plane for forward flight. Additionally, a NiMH battery is use to power the APM 2.6 board and all of its inputs. All batteries should be fully charged before powering the system. The V6AC Balance Charger

can be used for both LiPo and NiMH batteries.

Charging LiPo and NiMH Batteries:

- Connect the AC power supply to any wall socket and the other end of the power supply to the charger. Note: The charger can be power by a DC power supply with an input voltage of 11 V and 18V, and a draw current between .1A to .5A.
- Connect the positive and negative male leads into their corresponding port on the charger, then connect the male connectors to the female connectors of the battery. Note: When charging a LiPo battery, you should connect the battery balance connector into the balance socket on the charger.
- Use the stop button to select the type of battery that you want to charge.
- Press the start button to adjust charging parameters.
- Utilize the status buttons on the charger to select a charge current that is between .1C and .4C. Note: For a battery with a capacity of 5Ah the maximum charge current would be equal to 2A and the minimum charge current would be .5A.
- Hit the start button again to adjust the battery voltage
- Hold down the start button to start the charging process.
- Press start again to confirm the information that appears on the LCD screen.
- Remove all connections from charger when the charger indicates that the battery is fully charged.
- For trouble with the charger please follow the link, [29]
- Remember to follow all manufactures safety procedures during the charging of LiPo batteries.

APM 2.6 and Mission Planner:

It is mandatory for the user to download the Mission Planner software onto his or her operating system. The instructions for downloading Mission Planner can be found from their website, [30]. Once mission planner is installed, the user should proceed with setting up the APM by observing these procedures.

APM:

- Connect the four pin cable (compass) and five pin cable (GPS) into their respective port on the 3DR uBlox GPS with compass kit.
- Plug the compass cable into the I2C port and the GPS cable in the top GPS port.
- Connect the ppm jumper into signal pin 2 and pin 3.
- Plug ppm sum receiver into input port 1 and the output cables into their corresponding port on the Futaba R2006GS 6 channel receiver.
- Connect the micro end of the micro-usb cable into the micro port of the APM and the usb end into a computer with Mission Planner installed.
- Launch Mission Planner.
- Click on the initial setup tab and install VTOL firmware.
- Open the mandatory hardware tab and perform all required hardware calibration.
- Disconnect the micro-usb cable from the APM and the computer.
- Connect the ppm jumper into input signal pin 2 and pin 3.
- Connect the 3DR telemetry receiver into the telemetry port.
- Connect the APM power module in the PM port.
- Connect the 4 DC motor signal wires into their corresponding output ports.
- Connect the planes front motor signal wire into output port 5.
- Connect the aileron signal wire into port 6.
- Connect the elevator signal wire into port 7.

- Connect the rudder signal wire into port 8.
- Connect the 6V NiMH battery into the APM power module.
- Connect the EC5 connectors from the plane into the EC5 connectors from the 22.2V LiPo battery inside of the plane.
- Connect each of the EC5 connectors from the batteries underneath the plane into a EC5 connector from the wiring harness.

5) *Operation Instruction:* The operation of the aircraft must be broken into pre-flight instruction, in-flight instruction, and post-flight instruction. Each of these is highly important in ensuring safe operation of the aircraft. When operating the aircraft or dealing with any problems proper safety precautions must be taken. These include never approaching the aircraft while it is operating, unplugging the batteries before working on the aircraft, and always operating in a clear area free from obstructions or other people. When testing the aircraft the plane must be properly tethered to avoid it crashing into people or objects. Furthermore, the aircraft should never be flown above people.

Pre-Flight:

While preparing the aircraft before flight a structural inspection must be done in order to ensure that the aircraft is airworthy. This involves, first, doing a visually and manually inspecting all components of the vehicle. The plane and quadcopter frame must be free of defects such as holes and cracks. To ensure a good connection between the quadcopter frame and the plane, the frame should be lightly jostled by hand. If anything falls off or is loose then closer inspection will be necessary. The four motors on the quadcopter frame should be spun by hand to make sure they rotate freely and do not collide with any part of the aircraft. The front motor should be spun by hand too. The wiring from the motors, servos, and other peripherals must be followed from their ends all the way back to where they plug into the APM. If there are any disconnections or damages to the wiring then they must be inspected and fixed.

Next, it will be necessary to attach the batteries to the underside of the aircraft as well as the 3DR and any other external accessories. It is at this point that the aircraft will have all the necessary components to fly and be fully assembled. Thus, the center of gravity will need to be checked. This will ensure that the aircraft will be optimally balanced for vertical flight and will fly level in horizontal flight. To execute this, the aircraft should be lifted up at the bottom at a point under the wings and centered on the body. If the plane leans towards any direction and does not balance then the hand holding the plane should be moved to a point either closer to the front of the plane or the back. The idea is to find the point where the plane does not fall backwards, right, left, or extremely forward. If the plane tilts a little bit forward than this is acceptable. The ideal center of gravity should be under the wings of the plane. To get to this point then the batteries underneath the plane can be moved to where they correlate the desired center of gravity.

The next step is to make sure that the control surfaces of the aircraft are functional. These include the ailerons, elevator, rudder, and flaps. The transmitter can be used to activate the servos which control these surfaces. Each surface should be tested individually. If a control surface does not respond properly then the servo connected to it should be inspected. Once all the control surfaces have been tested and respond properly then the throw values must be set. The throw values are set to control the amount of deflection each of the control surfaces undergo during their maximum extension. For this aircraft the throw values should be set for the ailerons, elevator, and rudder. The ailerons have values of 25mm up and 20mm down. The elevator has values of 20mm up and 20mm down. The rudder has values of 35mm left and 35mm right. For further instructions consult the manual for the plane[?].

After this then both the plane and the quadcopter must be activated. This is done through Mission

Planner. In Mission Planner the aircrafts APM must be selected and linked to. This can be done either through the MAV link or wirelessly through the 3DR telemetry kit. After this the proper firmware must be selected. For the current purposes the quadcopter firmware should be installed on the aircraft. Once this is done then there should be some indication from the aircraft and Mission Planner.

At this point the onboard sensors need to be calibrated. This includes the magnetometer, gyroscope, gps, and barometer. In Mission Planner, the orientation of the plane can be monitored as a user tilts the plane forwards, backwards, left, and right. This will ensure the gyroscope and accelerometer. The calibrations involves lifting the plane and moving it around so physical strength and dexterity is required. After making sure the aircraft is in a clear location and free from any obstacles then it is ready to be armed. The plane is armed wirelessly with the Mission Planner software. At this point the aircraft is ready for vertical takeoff.

In-flight:

While taking off the aircraft can be flown in either manual or autonomous mode. Until autonomous mode is proven then the desired takeoff will be manually. Before takeoff, the aircraft must be propped up from the back so that the quadcopter frame is level at a horizontal. This ensures that when the throttle is applied the thrust will be directed vertically. To manually take off, the thrust joystick on the transmitter should be slowly pushed up. The farther up the joystick, the more thrust will be generated. The plane should be throttled to give it enough thrust to ascend at the desired velocity. The plane should only spend a minimal amount of time in the region below about 3 feet. This is in order to minimize the effects of down wash which can be highly detrimental to the aircraft. Once free from this range the throttle should be carefully applied until the aircraft reached the desired operated height.

While hovering the effects of the aircrafts asymmetry and of the environment will cause the flight to be unsteady. The aircraft will attempt to compensate for these forces with the PID controller in the APM. The plane can also be steadied and maneuvered using the joystick that controls the pitch and roll. Ideally, the aircraft will be turned to face the wind (if any). This will allow for the airflow to travel over the aircrafts wings which will then generate lift. In doing so, the aircraft will be more stable and will have the best conditions to transition to horizontal flight.

When landing, care should be taken as to the landing zone. The landing zone must have minimal grade, be free of obstacles, and be of adequate space. To land the throttle must be decreased slowly. The rate should be such that the aircraft does not descend rapidly. After traveling down to a height of about 2.5 feet then the throttle can be dropped more rapidly so to minimize the ground effect. Once it makes touchdown with the ground, the throttle can be cut. At this point the plane should not be approached by any means as it is still armed. The plane should then be disarmed and then it can be approached for post flight operations.

Post-flight Instruction:

After the aircraft is disarmed then the first step is to disconnect the batteries to eliminate any chance of the propellers turning on. The propellers are large and spin at a high speed so they can be extremely hazardous and cause bodily injury. Proper care must be taken at all times to never be within the range of the blades while the power is connected and the system armed. After the power is disconnected then the propellers may be removed from the four quadcopter motors. Then the rest of the electrical components such as the APM and 3DR telemetry kit should be unplugged and removed for safe transport. The wings of the aircraft should be removed and, if transporting in a car, the quadcopter frame should be detached from the plane. When everything is detached each of the components (wings, quadcopter frame, electronics, and plane frame) should be treated carefully and stowed safely so as to minimize damage to the fragile parts. The batteries should be charged as soon as possible so that they are not stored empty. This is detrimental

to the LiPo batteries.

6) *Troubleshooting:* There are various problems that may arise with this project. These include but are not limited to:

APM not connecting to Mission Planner:

- Ensure that the USB cable is properly attached to the APM and the computer running Mission Planner.
- Ensure that the proper port and baud rate on Mission Planner are selected.
- If the above does not work, try to unplug and plug USB cable back in to reset the connection.
- Try a different usb cable.
- Try a different computer.

Aircraft not turning on:

- Check that the batteries are charged using the charger.
- Ensure that the proper port and baud rate on Mission Planner are selected.
- If the above does not work, try to unplug and plug USB cable back in to reset the connection..
- Try a different usb cable.
- Try a different computer.

The aircraft not responding to inputs:

- Check that the plane is on.
- Make sure that the transmitter is on and working.
- Check to see that the firmware was properly installed onto the APM from Mission Planner.
- Check to see that the wiring is intact and properly connected.
- Try pulling sensor data from Mission Planner through wireless telemetry.
- Reset APM and Mission Planner.
- Refer to APM manual.

The aircraft flying erratically:

- Land immediately.
- If aircraft was in vertical mode, check motors and components related to the quadcopter frame.
- If aircraft was in horizontal mode, check control surfaces and components related to the airplane flight.
- If problem is in vertical mode and the motors and components of the quadcopter frame appear to be in working order, then recalibrate PID control values.
- Refer to either the plane manual or the APM manual for further information.

Wireless signal being lost:

- Check to see that 3DR telemetry is properly connected to computer usb port.
- The aircraft should automatically land itself if the signal is lost so proceed to the last known aircraft location immediately.
- In the future, attempt to minimize obstructions between the computer, transmitter, and the aircraft.

Other Difficulties:

For all other problems, refer to the Telemaster plane manual, the Futaba transmitter manual, the APM manual, the 3DR telemetry kit manual, the Mission Planner help guides online, and various forums relating to the problem at hand. There is a wealth of information on the internet and it must be utilized to solve problems. Chances are that the problem at hand has been experienced by someone else or someone else has faced a problem related to the one at hand.

7) *Regular Maintenance/ Service:* This hybrid design combines many moving and electrical components that should all be checked before operation to avoid injury and damage on the plane. The plane

should be checked before and after every flight as detailed in the operation instructions section. Other than preflight and postflight checks the pieces that should be checked regularly should be the motors, batteries, and the velcro attachments. The DC motors have a long lifetime as long as they are maintained properly, so it is recommended to oil the bearing on the motors every year at least once and keep them away from wet and dirty situations. Batteries will eventually need to be replaced. There are proper ways to charge, use and store batteries and these easily be found online.[34]. The search shows the user the proper way to use the battery and will allow the user to use the battery to its fullest capabilities until it needs to be replaced. The velcro straps should be replaced every year depending on the use of the product. Velcro tends to deteriorate after continued use, so it is recommended that the straps be replaced at least every year at minimum. If excess deteriorated is noticed before a year, the straps should be replaced. It is important for the user to perform the preflight and postflight test every time the product is used. This will allow the user to catch potential problems early so to avoid major problems in the future.

8) *Spare Parts:* Safe operation is key to avoiding the need for spare parts, however there are a few parts that are recommended as spare parts because there is higher risks of these being damaged and having a need for replacement. One spare parts to keep on hand are the propellers. The propellers, there is always risk of propellor damage when flying, so to limit down time, at least one extra counter clockwise and one extra clockwise propellor is recommended to be kept by the user. Batteries have limited life time, so having spare batteries is a necessity. Keeping spare batteries will make flight easier for the user as charging individual battery can be tedious. Another spare part to keep is extra Velcro straps. These can be purchased on a yearly as they are recommended to be replaced every year. The Velcro can also be damaged by improper use, so having spare strap will be essential. Lastly, spare signal wire will be needed. Many times loss of connection is due to faulty signal wire and so having a spare set of signal wires is also recommended.

9) *Summary:* In summary, this report lays out the operation of all components of the VTOL vehicle. Care must be taken when flying this vehicle because it can be dangerous for inexperienced pilots. Any operator should be properly trained before operating vehicle to ensure their safety as well as others. Remember that parts can be damaged during flight and in storage, so it is crucial to do pre and post check flights to ensure their reliability. Please follow all instruction in this manual to properly and safely fly the vehicle.

V. DESIGN OF EXPERIMENTS

For Team 8 to compete in the 2016 AUVSI competition, safe flight both in manual and autonomous mode must be reached. To reach safe flight in both modes, Team 8 had to come up with a number of successive tests to complete before semesters end. The basis of these test surrounds the capability of the Ardupilot APM 2.6. There are various modes that come equipped upon purchase that Team 8 would like to take advantage of. The main aspect that needs to be tested is the APM 2.6 ability to self correct for any instability or misalignment within a certain range. Team 8 did some preliminary research which can be seen in the research section, the most important being the capability of changing the PID controls with mission planner. After research, the team was confident the APM would correct for the added weight and shape of the Senior Telemaster plane. Team 8 also kept in mind all Federal laws and regulations and has tethered the quad to the ground before running any test within 5 miles of the airport as recommended by Dr. Collins [35].

A. *Experimental Testing*

Before every flight a pre-inspection should be completed so that the team is positive nothing will move around in the plane or disconnect in flight. The APM should be calibrated for correct data acquisition. The team should also double check that manual override is operational as the pilot should be able to override the autopilot if any unexpected error occurs. The weather should also be checked before every

flight, this will ensure that operation is done in safe working conditions and that if there are any changes in the environment that they will be documented and used when analyzing data. Again the system should be set to the desired flight mode which will allow the system to sense and compensate for any minor changes in the system. A minimal height of about 4 feet should be used during this testing or enough so that all the capabilities of the plane will still be able to be tested. As stated earlier, a tether, in this case braided fishing line, was used to ensure safety and so the team stayed rules of the FAA and the university. It should also be noted that the spare Senior Telemaster plane was used for all the tests. The older version of the Senior Telemaster which was used had about the same center of gravity, size, shape, and weighed more than the existing plane. This translated to a better test for the functionality of the plane and allowed all the data acquired to be easily transferred to the existing Senior Telemaster.

These tests will begin with a simple manual flight of the quadrotor attachment. The manual test flight will allow for Team 8 to ensure full capability of all components of the quadrotor while also maintaining full control. It should also be noted that temporary legs were added during these flights as the quadrotor alone no longer has the added landing gear of the plane. To accomplish this, the quadrotor system was connected to the APM 2.6 which was then connected to mission planner and then was switched into manual flight mode. With manual flight mode engaged, the pilots will be able to slowly initiate the throttle until the plane lifts off. If the center of gravity is located correctly, the motors and propellers are balanced and the outdoor conditions (wind) are minimal, then the quad should fly straight up with limited movement in any direction. Once this is accomplished the pilot can test all movements in pitch, roll, and yaw. With these three movements tested and considered stable, the quadrotor should be landed and set to autonomous mode.

The next step is to activate autonomous flight and set the mode to autonomous/loiter. This will be done to fully run all required autonomous capabilities, such as waypoint navigation and RTL (return to launch) mode. The loiter mode allow the pilot to flip a switch and regain control if the quad becomes out of control. Because autonomous mode has self stabilizing software, the flight will be much smoother than the manual operation, as the APM will compensate for almost any instabilities in autonomous mode. In order to ensure there are no problems with communication during flight, the flight plan should be drawn using Mission Planner Software and loaded onto the APM. This test needs to be run to ensure that all functions work correctly and that stable flight is achieved before adding an unsymmetrical object. If stable flight is achieved and VTOL works as it should, the plane can then be added.

The third test to be run is manual flight with the full hybrid quadrotor minus the wings of the plane. Team 8 decided a step by step approach was needed here and that the wings would add further parameters making it much harder to calibrate. So with the quadrotor attached to the plane base, manual flight should be completed first to ensure functionality. This manual flight will be similar to the first test in that stable controlled flight is expected. The plane should be mounted such that the center of mass is still about the middle of the quadrotor. This will mitigate the changes of the system and only leave the drag of the body as the new parameter. The biggest factor of the body will now be the tail of the plane, as it was estimated by the group to change the yaw and pitch of the whole system if not constrained or calibrated correctly. In order to mitigate changes of the system the rudder should be placed and locked in the full straight position and the back flaps should also be locked in the full straight position. With these two variables now constrained, Team 8 can now fly manually to run tests. While flying, the pilot should call out all adjustments he or she makes so that the team can record the verbal responses and then compare them to the data collected by flight planner. The pilot should again test all movements of the quad and see if they are affected greatly by the body. The goal here is to check that the system can still obtain vertical takeoff and landing without instability or major changes. Adjustments should be made if necessary and then autonomous flight should be tested.

Autonomous mode is then tested with the full hybrid model minus the wings. With autonomous mode activated, the plane should be tested again in all aspects. While running these test, the team kept an eye out

for all unusual movements so that they can be documented and compared to the flight data collected. With all the data collected and analyzed, the team should be able to determine whether the APM self-corrected for the unsymmetrical object or not. When the team has made the necessary adjustments and determined stable flight in autonomous mode is achievable, then they should attach the wings and continue testing.

The next step in testing is to attach the wings and perform a manual flight test. As mentioned before this will ensure the team can operate all aspects of the plane with minimal changes. The team will have to now account for the added drag of the wing and the added lift created when moving forward. As in previous tests the moving parts of the plane should again be constrained as to limit the capability of altering the parameters in the test. As in the first two manual flights, the hybrid model should be tested through all maneuvers. At this point the plane will be at its heaviest testing weight, so throttle checks should be run to ensure that the teams estimated throttle capabilities were met. This can be done by making adjustments to the throttle to gauge how much throttle is being used. The team will start with 40 percent and then adjust from there to find out where a 1 to 1 ratio is met. Once the plane has achieved a 1 to 1 ratio the team can then extrapolate what percent throttle is left and how much thrust they will be able to achieve. This will allow the team to double check their calculations made at the beginning of the year. The next step is for the pilot to go through and test all movements (pitch, roll, and yaw) and see how the added wings affect flight. The data collected and the observations made will let the team know what is the next step.

If all goes well the team will have one of three scenarios occur: The APM will self-stabilize with the already existing code, the APM will need to be calibrated to adjust for the symmetry by adjusting the correcting factors and changing the PID controls, or it will be determined that the APM cannot adjust for the added plane alone and sensors will need to be added and coded to compensate. If either of the first two situations are met, then the adjustment can be made and autonomous flight should be tested next. If the third situation occurs the team will have to determine what sensors should be added from the data collected and then add those sensors and complete the coding process. Regardless of what situation occurs, the next step will be to fly the complete hybrid plane and test autonomous VTOL as well as the other capabilities of the APM.

With the APM calibrated the plane should again be run through all the capabilities in autonomous mode while keeping a close eye for any minor malfunctions, such as loose motor mounts, as they can turn to major malfunctions if not corrected right away. Data should be collected using the APM and Mission Planner software. With the data collected the team should be able to see the effects of the full plane in autonomous mode.

B. Results

Team 8 has run through all the tests explained above and come to a final conclusion about what must be done to fully correct for the asymmetrical hybrid quadrotor. Before running any of the aforementioned mentioned tests, Team 8 spent a few weeks learning the Mission Planner Software. With the APM and the Mission Planner Software Team 8 was confident that achieving stable flight was possible. With detailed knowledge of Mission Planner and its adjustability, Team 8 set out to run the first test, which is simply the quadrotor attachment. To accomplish this the team had to add temporary legs to the device as well as extra weights. This would allow the quad to have a stable landing and a center of gravity about the middle of the device. With the preflight checks completed, Team 8 tested the quadrotor attachment manually. The result was as expected in that stable flight was achievable. The pilot slowly raised the throttle until the quad reached a one to one ratio. Once one to one ratio was met the pilot increased throttle to achieve enough height to run the pitch, roll and yaw tests. During this test, it was noticed that the throttle was set to too high increments. This meant that the pilot could either achieve above the one to one thrust to weight ratio or below it. This meant that the pilot had to constantly switch between about 30 percent to 50 percent throttle to maintain a steady hover in one position which wasn't favorable. After analysis the

team concluded that the thrust values should be changed to more sensitive values but that overall flight was very stable enough to continue.

The autonomous test of the hybrid attachment was then conducted. As this was the first time the team had conducted autonomous flight the team was very careful to double check all possible problems and create a correct flight plan. The hybrid vehicle was then set and armed in autonomous mode. This flight was again successful with the exception of the altitude verification. Before flight, the team assumed the values to be in US units as opposed to Metric units. The team also assumed that the relative altitude was set to zero. Not accounting for the relative height change and also no accounting for the units being in metric resulted in the quad flying above 16 meters high in the first test. This can be seen on Figure 20 of the altitude and relative altitude which have huge spikes and show the separation of relative and actual altitude.

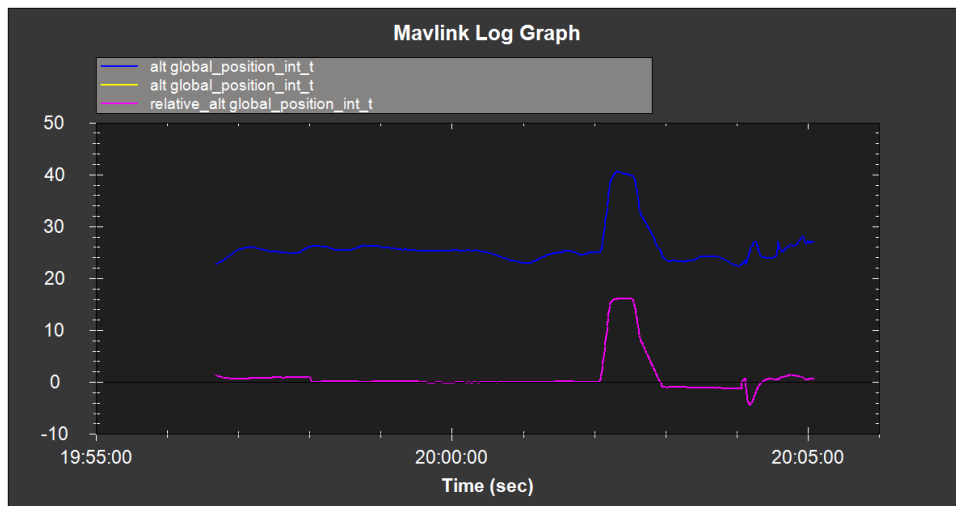

Fig. 20. Altitude vs. Time

When disregarding the altitude the flight plan was followed exactly as it was written and it followed the waypoint navigation to its desired position. From this test Team 8 quickly adjusted the height parameters. Team 8 also noticed a slight instability during takeoff, but this was attributed to the ground effect created by the rotors as the plane was completely symmetric and the data didnt show any outlandish jumps in the data.

The plane body minus the wings was added to the quadrotor model and the APM was recalibrated. Team 8 made the corrections observed from the first two tests and set the hybrid model up to fly manually. It was very important for the team to make sure that the center of gravity again was about the middle. Team 8 secured the back flaps and rudder as mentioned above and tested the maneuvers of the plane. It was immediately noticed that the once the plane was above the estimated distance to avoid ground effect, that the tail was affecting the flight as the plane began to rotate about the yaw, or the z axis. The wind that was present during testing created a yaw moment that had to be corrected by the pilot to achieve completely stable flight. The data did not show any significant change in the pitch as estimated and so the major factor by adding the plane was found to be the yaw movement. In Figure 21 it the graph of the yaw degree vs time can be seen. The figure shows the last four flights conducted. It is very clear that the degree of yaw was decreased as Team 8 adjusted the PID controls of the APM to compensate for the yaw moment. It should also be noted that the negative yaw is obtained by turning around and flying back to the home position. Autonomous flight with the hybrid model minus the wings was now tested. The manual test went well and the team determined that the yaw movement would be corrected by the

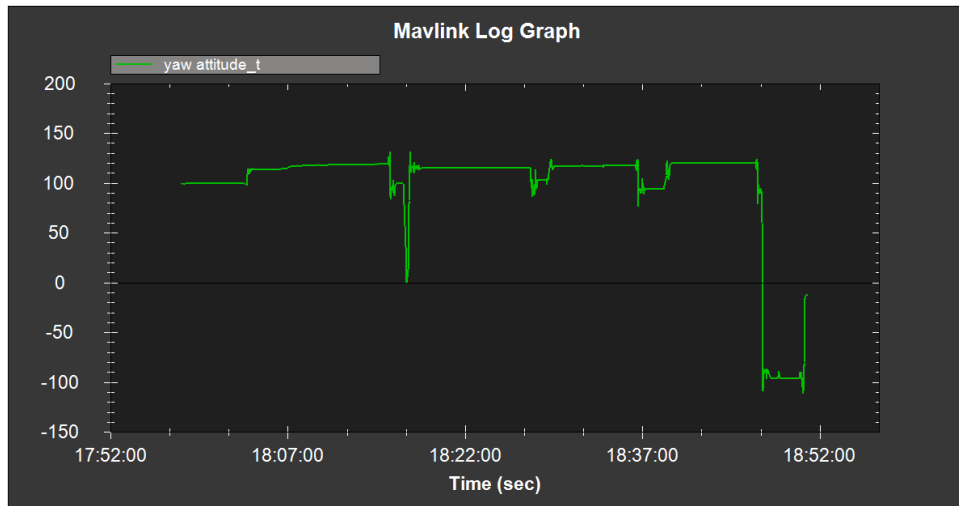

Fig. 21. Yaw vs. Time

APM. The preflight checks were performed and the flight plan was created and loaded to the APM. At this point, the team had achieved a better understanding of Mission Planner and was able to create a flight plan that would then be used in all the upcoming flight tests to keep the data as similar and comparable as possible. This flight plan can be seen in Figure 22.

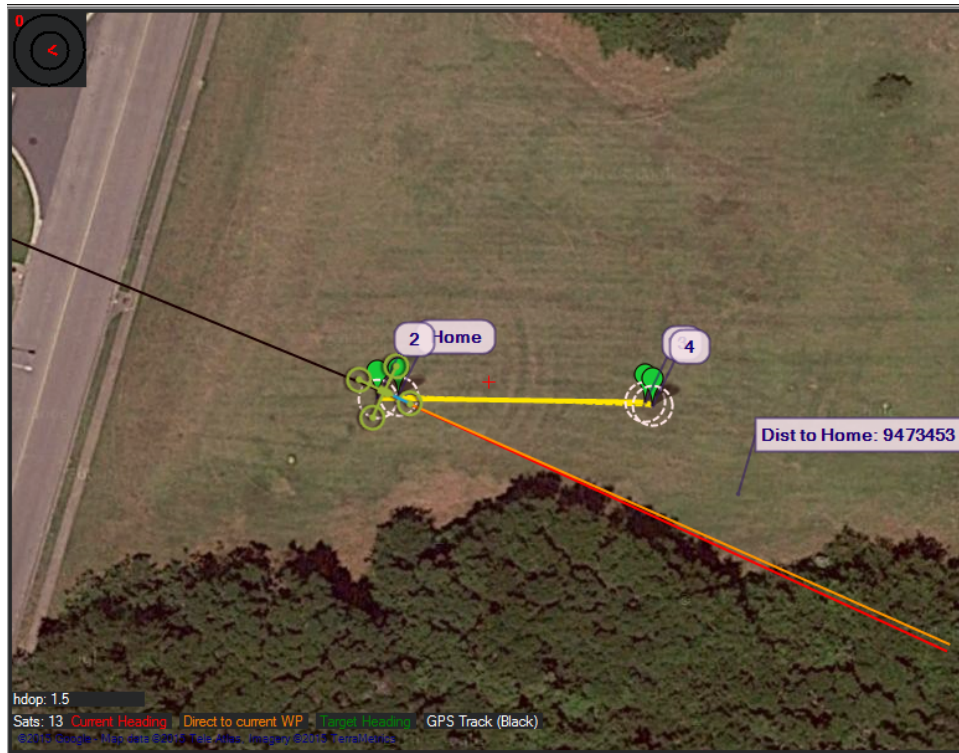

Fig. 22. Flight Plan

The team ran the flight plan three times to observe the behavior thoroughly. The flight plan was for the plane to take off to a set height and then proceed forward to a waypoint where it would stop and

then descend. Through the tests the team found that the control of the yaw had to be adjusted to a more fine correction factor. The APM corrected for the sway in the yaw direction due to wind; however the movements were very quick and sudden and created as swaying motion that was eventually corrected. The pitch movement was seen to be affected by the flight as well. After analysis the team determined that the cause of the instability in the pitch direction during was due to the velocity of ascent and the forward flight velocity. The hybrid was ascending so quickly that once it reached the appropriate height for moving forward it would stop abruptly and create a sway while transitioning. This was fixed by slowing the vertical velocity to 0.5 m/s so that the transition to horizontal quad flight was much smoother and didn't cause a sway. The second change made was that of forwards flight velocity. The same problem of swaying was apparent when the plane transitioned from horizontal flight to vertical descent. So the team again lowered the horizontal flight velocity from 2.5 m/s to 1.5 m/s which decreased the extreme swaying of the hybrid model significantly. After all the adjustments were made the quadrotor hybrid flew stably with only minor movements which could be attributed to wind and other external factors, shown in Figure 23. The graph shows variations in pitch angle magnitude, which which is directly correlated with the decrease in speed from flight 1 to 2.

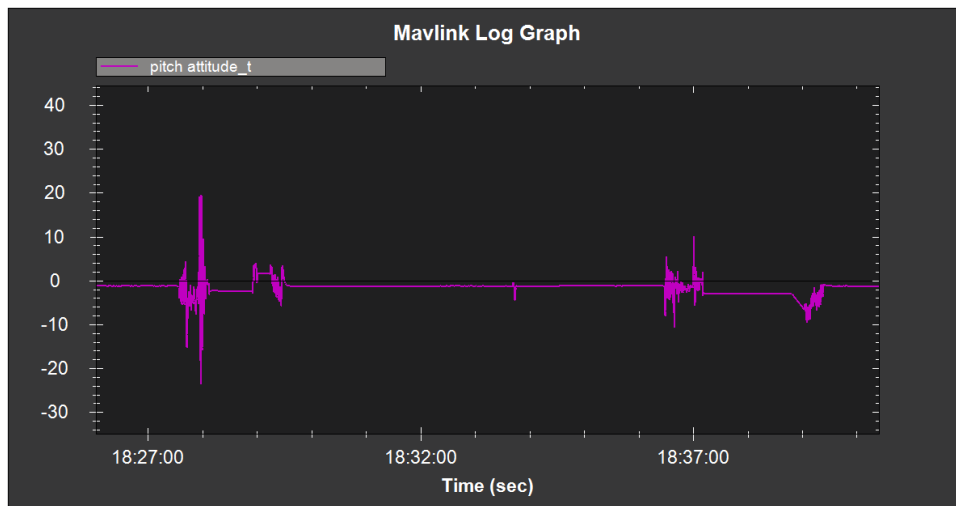

Fig. 23. Pitch vs. Time with Respect to Speed

The next step in the testing plan was to add the wings so that the complete hybrid model can be tested in manual mode. Like the other manual tests only a few observations were made. Again the tail was seen to affect flight; however the wings didn't cause any noticeable effects in any of the three movements (pitch, roll and yaw). The controls for yaw movement were again looked at and adjusted accordingly. The other aspect which was inspected during this test was the throttle use and how accurate the thrust to weight ratio calculated ended up being. During test the throttle was observed to be slightly above the 50 percent marker to obtain one to one stable lift off. With the thrust value being about 50 percent, it confirmed that the calculated value was correct and that the motors were indeed sufficient. The percentage over fifty percent can be attributed to extra parts added to the final design which weren't added in the beginning of the design as well as the test plane weighing more than the actual plane used for calculations. After these tests were conducted, it was determined it was safe to attempt autonomous flight with the complete hybrid model.

At this point, Team 8 is thoroughly confident that the APM can make the adjustments needed to achieve the goal at the beginning of the semester which was to obtain stable autonomous vertical takeoff and landing. The team again studied the data obtained from the previous flights and made the necessary

changes in the PID controls to test autonomous flight with the full hybrid vehicle. The tests yielded an almost perfect flight with a few unstable stints through the flight. The instability in this test can again be attributed to the wind during testing. Wind during testing was measured by using the website usair.net. This showed the winds speeds at the time of the test to be approximately 5 mph, which could have affected the plane during the flight and caused the instability seen during flight. This instability and its correction can be seen in Figure 24 as a graph of PWM vs time is shown. The PWM value is a relation between the signal and thrust output to the motor. So it is clearly shown that large peaks occur due to wind and are then corrected by the APM.

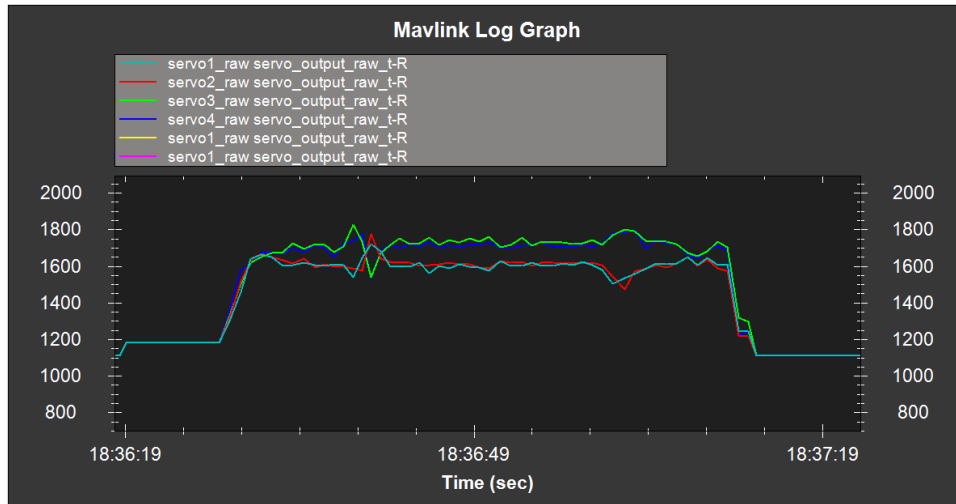

Fig. 24. PWM supplied to motors vs. Time

In conclusion, it was confirmed that the APM was in fact capable of correcting for the asymmetry of the Senior Telemaster plane as expected. Through the test flights, the team did notice a few changes due to the addition of the plane. These effects seen were: a rotating moment about the yaw axis, a swaying motion during transition between horizontal quad flight and vertical quad flight, and subtle waypoint corrections causing a few minor jolts to the system. Team 8 considered these results as a success as the goal was to achieve stable vertical takeoff and landing. The effects seen in the test have been corrected enough so that the instabilities seen before are very limited. It should also be noted that the ultimate plan for the quadrotor design is to only takeoff and land vertically and not fly forward as tested. So all of the transition flight problems created will not necessarily be created in the actual operation of the plane. Ultimately the data collected will allow Team 8 to fully understand the behavior of the hybrid design and correct the necessary PID controls to be able to give a functioning VTOL model to next years team. Also, by already performing the waypoint navigation and quad transition, the data collected can be used to fully program the actual transition from quad flight to forward plane flight. Team 8 has confirmed the capabilities of the APM 2.6 and has accomplished the goal of achieving autonomous takeoff and landing. Having accomplished the goals sets forth for this year will set the next years group up with a design that should allow them to be very competitive in next years 2016 AUVSI competition.

C. Future Testing for Transitional Flight

Mission planner only allows one firmware to be uploaded to the Ardupilot at a time. This makes it impossible to load both the fixed plane and quadrotor firmware simultaneously. However, it is possible to create your own custom firmware to upload through mission planner. To accomplish this, the team must obtain the source code for both the fixed wing and quadrotor firmware packages. Once the users

are familiarized with the coding, it should be modified to perform the following transition in the form of a function.

The quadrotor is capable of generating sufficient lift to suspend the plane into the air. While the plane is hovering, it should begin forward motion with a slight tilt. The front propeller that is used to pull the fixed wing through the air should then be activated with a low RPM as to minimize the jerk force that could generate a moment which would flip the plane over. The RPM of forward propeller will then need to be increased gradually to obtain the necessary speed to generate lift. Mission Planner recognizes the vehicular speed in flight so this speed should be used as a reference to estimate the lift force being generated by the wings. As the wings lift force increases with the forward velocity the quadrotor can begin lowering the lift force it is generating. Once sufficient forward speed is obtained then the quadrotor frame can be powered off and the aircraft can be flown solely as a fixed wing plane.

To transition back from fixed wing flight, the aircraft will have to slow down to a speed where it is still capable of generating sufficient lift with its wings. The quadrotor propellers will then be turned on with a low RPM and gradually assume control as the primary lift mechanism of the aircraft. It would be favorable for the quadrotor frame to attempt to continue at the velocity of the fixed wing flight but without having a large effect on the angle of attack of the wings. The transition for both situations should be gradual as to minimize any sudden jerks from quick acceleration or deceleration of the aircraft.

VI. CONSIDERATIONS FOR ENVIRONMENT, SAFETY, AND ETHICS

Environment, safety and ethics are very important when doing any engineering project. All these parameters must be considered before any project is begun, to eliminate the potential disastrous effects.

A. *Environmental Considerations*

The environmental effects that are relevant when referring to Team 8 would be those due to chemical waste and potentially debris scattering. To control the chemical effects on the environment, all chemicals have been arranged to be stored in designated sections of Team 8s portable. This makes the team aware of their position and minimizes the chances of them spilling. The team also had to be conscious when using the chemicals for fabrication (carbon fiber, plastics, epoxy), as the waste materials had to be cleaned up and disposed in the proper manner to avoid safety and pollution concerns. Finally the craft is tied down with a tether during test flights to prevent the craft from flying away if control is lost during flight. This will prevent a rogue craft from flying around and possibly hitting trees, buildings, and other property causing damage and debris spreading. If a crash was to occur the potential for spreading chemicals to the environment is large as the plane consists of many types of plastics as well as three large LiPo batteries. To mitigate these effects the team has a list of materials which are to be checked off and found if a crash does occur.

B. *Safety Considerations*

1) *Pre-Testing:* Before the project began, a safe work space in the portable room Team 8 needed to be cleared of excess material, and some of the furniture that constrained movement in the portable had to be arranged. If an emergency situation had arisen, while the room was in its original condition, it would be extremely difficult to navigate outside safely. To address this risk, the team rearranged the furniture, threw away the garbage material, as well as organized the other material that could be beneficial to future use. Although no flight test were done in the portable, it was important to maintain a cleared area so that no debris could get into the motors or any other joints on the craft; this minimized the risk of damaging any components or persons involved in the project.

a. *Motor Testing:* Before testing the motor connections, team 8 ensured that the battery supply to the ESCs were fully disconnected. The propellers were removed to prevent them from cutting anyone and also to disable the crafts from having the ability to generate thrust. With the propellers removed, use

Mission Planner to ensure the ESCs are connected to the appropriate port numbers. When choosing the firmware, a number is given to indicate motor placement with respect to the vehicle frame. Activate each individual motor to verify that they are in the same position as recognized by Mission Planner; also verify appropriate spin direction which can be adjusted by changing the connections between two of the three wires connected directly between the ESC and the desired motor. Failure to verify this information will affect the vehicles ability to properly navigate.

b. Radio Operation: It is important that the radio frequency requirements are followed so that there is no interference with military, emergency, or civilian transmissions. This will also ensure that the transmissions do not affect other teams competing. The frequency should be able to be adjusted in case their is need or desire for it to be done.

2) *Pre-Flight*: To handle the craft, the power supply to the ESCs must be disconnected to prevent the motors from arming. Failure to do so could allow the motors to begin spinning while the users are in the vicinity of the blades which would cause severe bodily damage. All component should be checked to ensure that all wire connections are correct and that nothing is able to break loose from the craft. Make sure that no material is stuck in between the motor coils effecting the motors ability to spin. A material in this crevice can lead to the motors not spinning, overheating, possible shock or fire. It is the user's job to be sure that the area is clear before arming the motors. Any loose wires must be tied down so that they are not cut in flight which would disable the vehicle ability to fly. Before the propellers are connected and the motors are armed, the craft should be tied down as to minimize the fly-zone to only the necessary range for the desired test. There is no need to have excess slack in the tether so tension should be kept on the harness. The applied tension will keep the propellers from cutting the craft loose from the harness. Every individual should be an extra 10 ft outside of the tethers radius so that they are not wrapped by the chord or in the vehicle's flight zone. Failure to do so can result in serious bodily injury. Before arming the craft no object which may be damaged or cause damage should be within a 10 foot radius of the plane. All persons should be at least 10 ft from the craft before the motors engage. Individuals within 30 ft should keep an eye on the vehicle at all times, so if control is lost they are able to navigate to safety. Anyone within a 100 ft radius should also be made aware that the craft is being tested to minimize their chances of bodily harm.

3) *In-Flight*: All flight testing was done outside in an open field with a tether attached to the quadrotor. The tether keeps the multi rotor constrained to the test area and prevents any rogue drones. Every individual is responsible for maintaining an eye on the craft during flight test. Failure to do so could risk injury of the individual. Every team member must maintain a safe distance of at least 30 ft at all times during testing. The tether added to the quadrotor will also satisfy all rules and regulations of flying the aerial vehicle set forth by the FAA and the university.

C. Ethical Considerations

Each individual in the group must have respect and give respect to themselves and to each other. This is important to maintain regardless of race, religion, or creed. The team is to work together at all times for the betterment of the team and not the individual; it is what makes a team successful. All rules in regards to the competition must be followed to ensure proper sportsmanship and competitive fairness; cheating is not tolerable. The guidelines, rules, and laws of the Federal Aeronautics Administration (FAA) can be found at the FAA website [36]

VII. PROJECT MANAGEMENT

A. Schedule

Team 8 planned out a schedule for both the Fall and Spring semesters of 2015 and 2016 since it was decided this project would span two years. With this, Team 8s main focus was to complete the quadrotor design in order to create the hybrid Senior Telemaster plane capable of autonomous takeoff and landing.

During the Fall semester, the focus of the team was to design an attachment that can mount to the existing plane passed down from last years team. Designing and selecting the correct components (materials, motors, props, etc.) encompassed the majority of the teams time. Only a few set backs were encountered during the fall semester and they were easily handled. One of these was the difficulty of communicating with the two team members studying in Brazil. With time, Team 8 was able to learn to communicate and work effectively, even with the international complications. Overall, the Fall goal to have designed an attachment for the existing plane was completed. To see the Gantt chart for the 2014 Fall Semester, refer to Appendix C.

During the Spring semester, Team 8s focus was to build and test fly the hybrid aircraft. Part procurement, as well the machining of raw materials, took up much of the first half of the semester. A major setback half-way through the Spring semester was discovering that the Adrupilot APM 2.5 and the 3DR Telemetry Kit, passed down from the previous team, did not work. These component was critical to the design as they controls all flight. This caused problems with the Team 8s budget and schedule. Re-ordering these parts caused a significant hit on Team 8s budget and set them back two weeks due to shipping turn around. Once Team 8 received the newly ordered Adrupilot APM 2.6 and 3DR Telemetry Kit, flight tests were begun. The team was able to get back on track with the testing of manual and autonomous flight. To see the Gantt chart for the 2015 spring semester, refer to Appendix C.

Throughout the year, Team 8 had other setbacks that were easily corrected and were able to stay on track to complete the final goal of the project. The critical path was not reached on time in the Spring semester a couple of times due to the broken parts. However, since the team did complete all milestones, next years team will be able to continue by working on the transitional flight of the aircraft, and then compete in the 2016 AUVSI SUAS Competition. The Gantt charts for the 2015 fall and the 2016 spring semester can be seen in Appendix C.

B. Resources and Facilities

Team 8 had multiple resources it was able to utilize during the Fall and Spring semesters. During the Fall semester, applications such as Skype and Groupme were used to communicate effectively with the two members of our team who were studying abroad in Brazil as part of the FIPSE program. Without these two applications, effective communication would have been extremely difficult. Once the team members returned in the Spring semester, the team still used the Groupme application to communicate to one another.

Team 8 was also able to use resources that were available to them at the FAMU-FSU College of Engineering (CoE). The CoE machine shop was used multiple times to fabricate the aluminum rods, carbon fiber rods, carbon fiber clamps, and motor mounts for the design. Along with this, the machine shop provided advice on our design to help ease the manufacturing of components. Also, the laser cutter at the High Performance Materials Institute Lab (HPMI) was used by Team 8 to cut the plywood base. Having an access to a machine shop and laser cutter benefitted Team 8 significantly to speed up their manufacturing and building process of their design.

In addition to the above mentioned resources, Team 8 had an abundance of knowledge passed along to them from professors about different aspects of their project. The consultations of these professors were used in multiple decisions and Team 8 would like to again thank the faculty for the help and support during this project.

C. Procurement

eam 8 was allotted a budget of \$1500 to complete this project. During the semester, Team 8 was able to stay within its allotted budget thanks to careful planning of funds over the first semester. After ordering all the parts necessary for the design, there was still over \$360 in their budget entering the spring semester. This was needed after after discovering the broken APM and 3DR Telemetry Kit. Replacing

these components cost about \$350. By carefully planning the budget for unexpected cost, Team 8 was just able to successfully order all parts. Team 8 considered cost a highly important factor when selecting components for the final design. Below, in Figure 25 (same as Figure 10 in Section IV-C3, Design for Economics) , a pie chart representing the cost of individual components used to build the aircraft is shown.

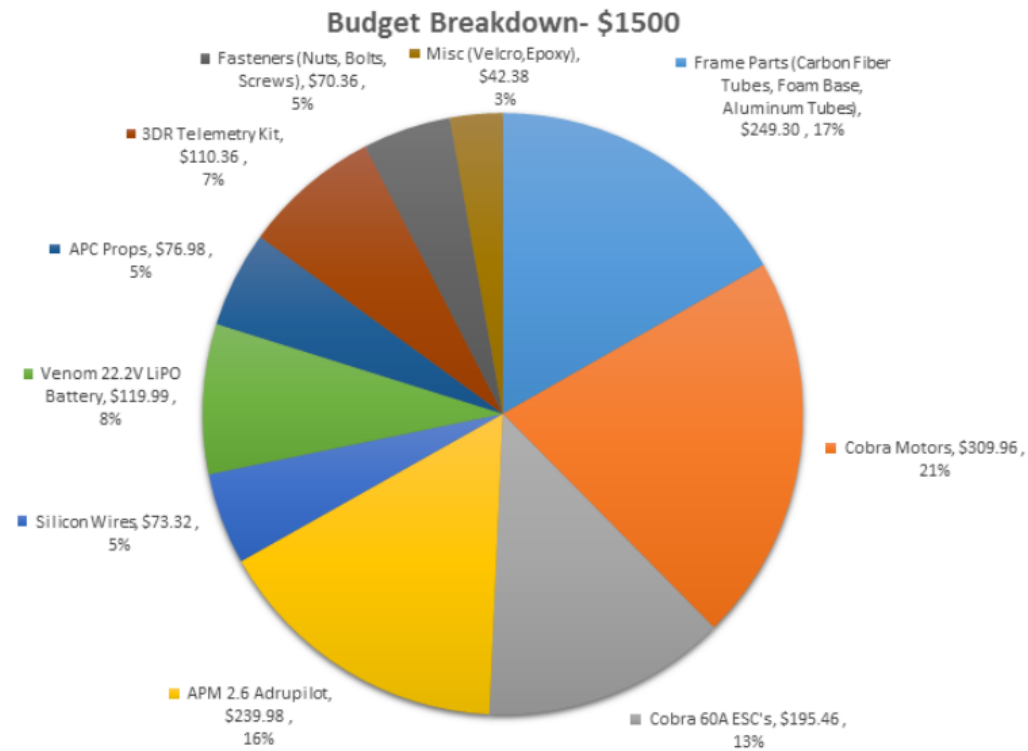

Fig. 25. Breakdown of expenses along with percentage of total \$1500 budget.

Team 8 used \$1488.09 of their budget, which is 99.2% of the total budget. Team 8 was able to stay just under budget, which was a large goal set at the beginning of the year. This goal was achieved even with the purchasing of unexpected replacement part. For a table of parts, quantity, and respective cost, refer to Table XIII (same as Table VIII in Section IV-C3, Design for Economics).

D. Communication

A previously mentioned, Team 8 had two of its members studying abroad in Itajuba, Brazil during the 2014 Fall semester. As a result, Team 8 used Skype to handle the all of its face-to-face communication between the team members during the Fall semester. Also, to set up meetings, the Groupme text messaging application was used. This was a simple way to include all members in one group chat for any information on the project. Once the team members returned for the Spring semester, the Groupme app was the main form of communication between group members.

For file sharing purposes, both Dropbox and Google Docs were used. With these two applications, the team was able to share files between each other with ease. Google Docs was used write all the reports because it allowed all of the team members to edit reports at the same time, from different locations. Dropbox was used to share any kind of CAD, pictures, video or excel files. This was beneficial to keep all members up to date on the project.

One area that Team 8 could have improved on was to communicate more effectively with its advisor. At the beginning of the fall semester, more frequent meetings would have helped established a better

Part	Qty.	Unit Price	Subtotal
Carbon Fiber 0.5" Arms	3	\$41.05	\$123.15
Industrial Strength Velcro	1	\$30.39	\$30.39
Double Bubble Orange Epoxy	1	\$11.99	\$11.99
APM 2.6 Ardupilot	1	\$239.98	\$239.98
12 AWG Silicon Wire	16	\$2.74	\$43.78
12 AWG Silicon Wire for ESC	1	\$10.04	\$10.04
12 AWG Male Wire Connectors	1	\$10.58	\$10.58
12 AWG Female Wire Connectors	1	\$8.92	\$8.92
Cobra 4510 420Kv Multicopter Motor	4	\$74.99	\$309.96
Cobra 60A Multicopter ESC	4	\$48.86	\$195.46
Venom 22.2V LiPo Battery	1	\$119.99	\$119.99
APC 18x5.5" Propellers	6	\$12.83	\$76.98
Resilient Foam Base	1	\$40.44	\$40.44
Aluminum 1x1" Beams	3	\$28.57	\$85.71
3DR Telemetry Kit	1	\$110.36	\$110.36
Hardware & Misc.	1	\$70.36	\$70.36
		Total	\$1488.09

TABLE XIII
LIST OF EXPENSES FOR EACH PURCHASED PART AND THE CORRESPONDING COST.

understanding of concepts and what goals the advisor would like to see met. Both the team members and advisor had conflicting schedules during the fall semester which limited the amount of time spent discussing the project. During the spring semester, Team 8 made an extra effort to communicate more regularly with advisors either through emails or face-to-face meetings. Keeping the communication lines open helped the team better understand what was expected of them during the semester and allowed them to better plan their time.

VIII. CONCLUSION

In conclusion, Team 8 was able to design, build, and test a hybrid aerial vehicle with VTOL capabilities. With the design phase being complete during the fall semester, the team was able to build the attachment and then run test flight during the spring semester. The test flights were used to determine if stable takeoff and landing was possible with the unsymmetrical shape of the vehicle. After learning about the micro controller, it was determined that it was possible to alter the parameters in the built in PID controller to help stabilize the vehicles. The parameters changed during the flight test were pitch, roll, yaw, and horizontal and vertical velocity. After analyzing data from each separate flight and altering the PID controller accordingly, Team 8 was able to achieve stable flight during takeoff and landing.

Vertical takeoff and landing has been achieved with the project. The future team will now need to work on the transition from vertical flight into horizontal flight. This transition will have to be done by creating a custom firmware that can be loaded to Mission Planner. The firmware for the plane and multicopter vehicles can be found online, but a function to switch between the two flight modes must be created since only one of the firmwares on mission planner can be loaded to the ardupilot at a time.

Another consideration for next years team are minor design improvements in the frame. First, larger carbon fiber tubes where the motors are mounted would help improve strength to handle the large thrust generated in the motors. Second, the motor mounts and clamp configurations could have padding added around the carbon fiber to reduce the damage that can be done from the compressive force of those components. Lastly, exposed wires are found on the aluminum rods and bottom of the attachment. These can be damaged easily and need to be either covered or ran through the inside of the aluminum rods.

To go along with this, next years team should take some time to get familiar with the controls of the UAV in manual flight and get certified to fly the fixed wing plane. This is beneficial in the case where a manual flight is needed to test some aspect of the plane. Also, Mission Planner is a very advanced and

useful tool for autonomous flight. All team members should have some familiarity with this program. For the best success, a few members should immediately begin going through the software so that they can know its capabilities and be aware of the locations of various items of information. Knowing these things can significantly reduce the learning curve of this multi disciplined project.

This years team could have done better with communication of information throughout the project as well as done better with managing the workload together. During fall semester, the team had two members in Brazil which complicated communication. Once they returned, communication improve greatly as the team was able to all sit down and have face to face meetings. Also, better delegation of work could have helped ease the workload. It took time to learn each individual's strengths, which then could be used to assign the correct tasks to the correct individual so they can succeed. Once these were determined, delegation of work and teamwork significantly increased.

Overall, Team 8 was able to accomplish their goal of creating a quadrotor attachment to give the existing plane autonomous VTOL capabilities. Whats left for next years team is to program transition flight and prepare the plane for primary and secondary objectives in the competition. With theses completed, next years team will be able to attend the competition and be highly competitive.

REFERENCES

- [1] AUVSI, Auvs. DRAFT 2015 Rules for AUVSI Seafarer Ch (n.d.): n. pag. AUVSI. AUVIS, 23 Oct. 2014. Web. 4 Apr. 2015
- [2] Derene, Glenn. "The Art of Flying Your Very Own Drone." Popular Mechanics. Popular Mechanics, n.d. Web. 10 Apr. 2015.
- [3] Latitude Engineering. "Latitude Engineering - Advancing Unmanned Aviation." Latitude Engineering. Latitude, n.d. Web. 10 Apr. 2015.
- [4] 3D Robotics. "ArduPilot." ArduPilot. 3D Robotics, n.d. Web. 10 Apr. 2015
- [5] Arizona State University, and Water. "Fluid Mechanics." DRAG (n.d.): n. pag. Arizona State University, 1 Aug. 210. Web. 10 Apr. 2015.
- [6] Cantrell, Paul. "Ground Effect." Helicopter Aviation. N.p., n.d. Web. 10 Apr. 2015.
- [7] Siegwart, Samir Bouabdallah And Roland, and Autonomous Systems Lab, Eth Zurich, Switzerland. Design and Control of a Miniature Quadrotor (n.d.): n. pag. Autonomous Systems Lab. Web. 10 Apr. 2015.
- [8] Cobra Motors. "Propeller Data Charts." How to Use the Multirotor Motor Performance Data Charts (n.d.): n. pag. Innov8tive Design. Cobra Motors. Web. 2 Oct. 2014.
- [9] Hobby Town. Instruction Manual. S.I.: S.n., 1993. Hobby Town. Web. 1 Apr. 2015.
- [10] 2003, Entire Contents Copyright, and Futz9032 For Futk55** V1. "Futaba 6 Channel Receiver." 6 E X A (n.d.): n. pag. Futaba. Web. 2 Mar. 2015.
- [11] Ties, Z., and Z. "Digital Balance Charger." BATTERY CHARGER BC-900 Instruction Manual INTRODUCTION: (n.d.): n. pag. La Crosse Technology. Web. 10 Apr. 2015.
- [12] 3D Robotics. "Mission Planner.-AduCopter" Mission Planner. 3D Robotics, n.d. Web. 10 Apr. 2015.
- [13] 3D Robotics, T. "Quick Start Guide." 3DR RADIO V2 (n.d.): n. pag. 3D Robotics. Web. 10 Apr. 2015.
- [14] 3D Robotics. "APM 2.6 Set." - 3DRobotics Inc. 3D Robotics, n.d. Web. 10 Apr. 2015.
- [15] Hardman. "Specification for Double Bubble Epoxy." DOUBLE/BUBBLE (n.d.): n. pag. Hardman. Web. 10 Apr. 2015.
- [16] ECalc. "ECalc - the Most Reliaibale RC Calculator on the Web." ECalc - the Most Reliaibale RC Calculator on the Web. ECalc, n.d. Web. 10 Apr. 2015.
- [17] "Static Thrust Calculator - STRC." Static Thrust Calculator - STRC. N.p., n.d. Web. 10 Apr. 2015.
- [18] Design for Manufacture Guidelines. Ascot: Steel Construction Institute, 1995. Web.
- [19] "ASM Material Data Sheet." ASM Material Data Sheet. N.p., n.d. Web. 02 Apr. 2015. Web.
- [20] "More About Hard Fiber, Fiberglass, Garolite, and Carbon Fiber." McMaster-Carr. N.p., n.d. Web. 02 Apr. 2015. Web.
- [21] "MatWeb - The Online Materials Information Resource." MatWeb - The Online Materials Information Resource. N.p., n.d. Web. 02 Apr. 2015. Web.
- [22] "Cobra CM-4510/28 420Kv Motor Propeller Data." N.p., n.d. Web. 02 Apr. 2015. Web.
- [23] "3DR Pixhawk." - 3DRobotics Inc. N.p., n.d. Web. 02 Apr. 2015. Web.
- [24] "T-Motor." RC Tiger Motor. N.p., n.d. Web. 2 Apr. 2015. Web.
- [25] "T-Motor ESC - 60 Amp, 2-6 Cell." RSS Specials. N.p., n.d. Web. 02 Apr. 2015. Web.
- [26] CED Technologies. "The Advantages & Limitations of Lithium Polymer Batteries." The Advantages & Limitations of Lithium Polymer Batteries. CED Technologies, n.d. Web. 10 Apr. 2015.
- [27] "Instruction Manual". , 1993. Senior Telemaster Plus ARF. Hobby Lobby International, Inc. Web.3 Apr. 2015.
- [28] "INSTRUCTION MANUAL for Futaba 6J-2.4GHz." , Futaba Corporation. Web. 3 Apr. 2015.
- [29] "Intellegent Digital Balance Charger V6AC Operating Manual." Web. 3 Apr. 2015.
- [30] "Mission Planner." Mission Planner. Ardupilot, n.d. Web. 03 Apr. 2015.
- [31] "ArduCopter." ArduCopter. Mission Planner, n.d. Web. 03 Apr. 2015.
- [32] "ArduPlane." ArduPlane. Mission Planner, n.d. Web. 03 Apr. 2015.
- [33] "3DR RADIOV2 QUICK START GUIDE." 3DRobotics. 3DRobotics. Web.
- [34] "Battery Basics: A Layman's Guide to Batteries." Battery Basics: A Layman's Guide to Batte. BatteryStuff.com, n.d. Web. 03 Apr. 2015.
- [35] CNet. "How to Know Where Not to Fly Your Drone - CNET." CNET. C Net, n.d. Web. 10 Apr. 2015.
- [36] "Unmanned Aircraft Systems." Unmanned Aircraft Systems. Federal Aeronautics Administration, 12 Mar. 2015. Web. 10 Apr. 2015

APPENDIX A PART DRAWINGS

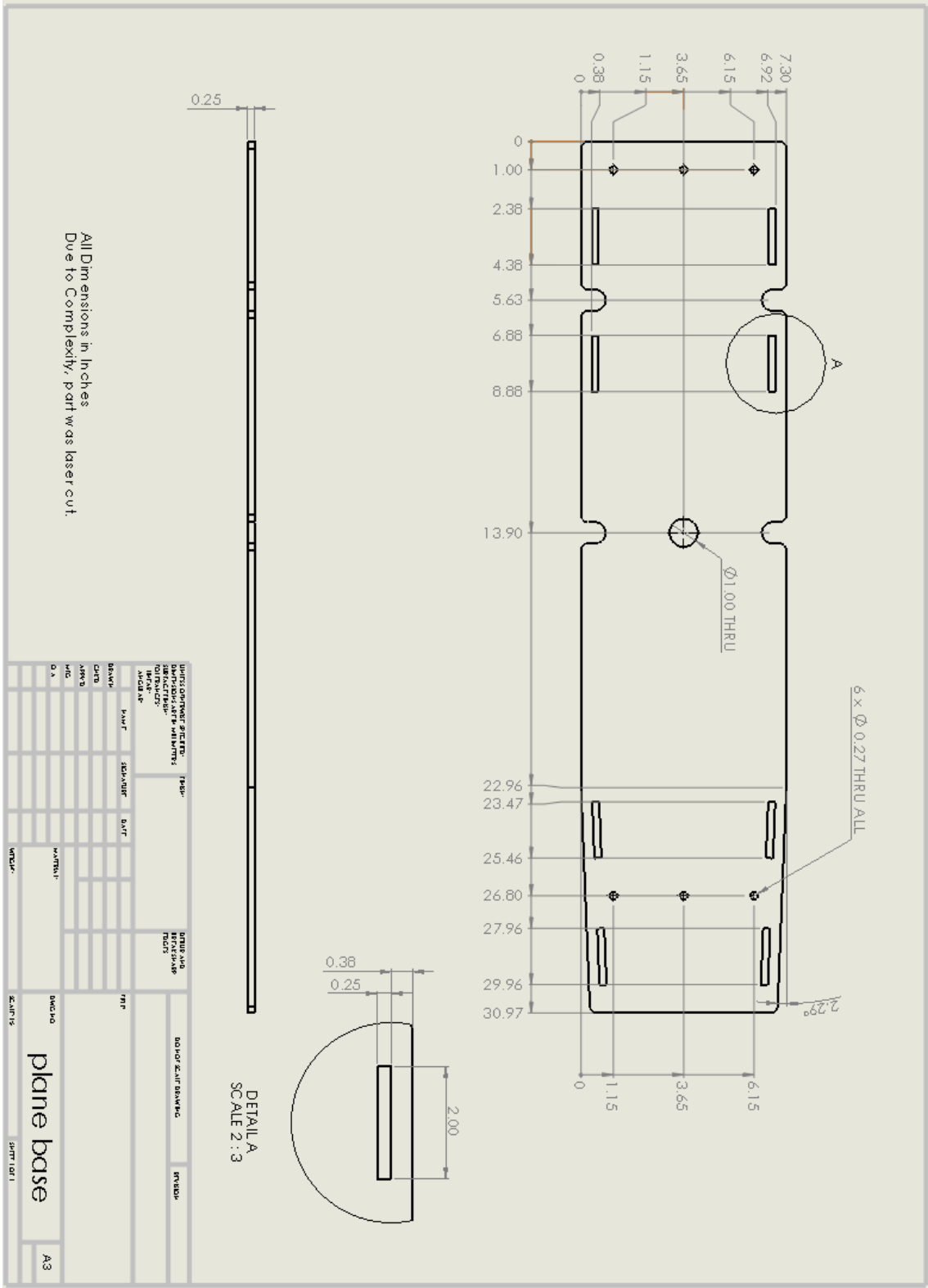

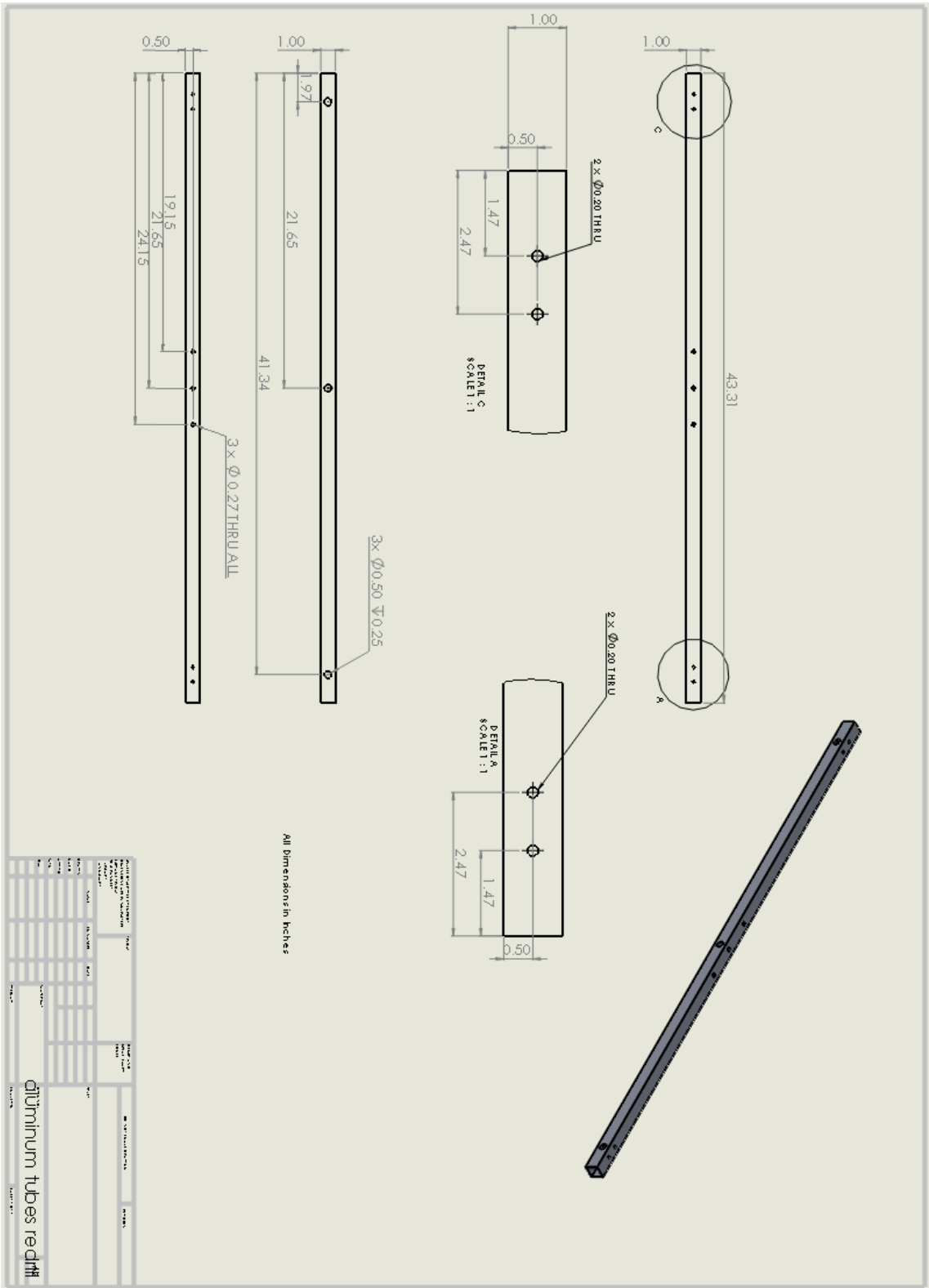

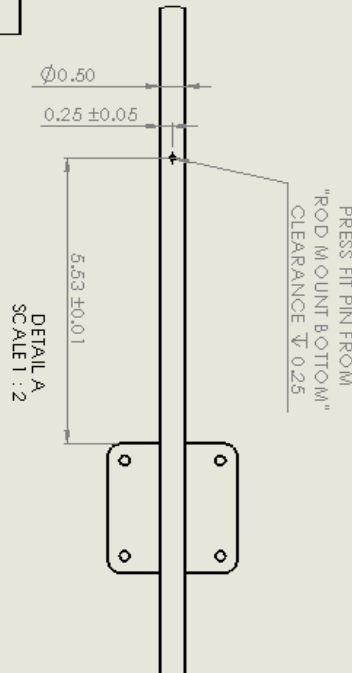
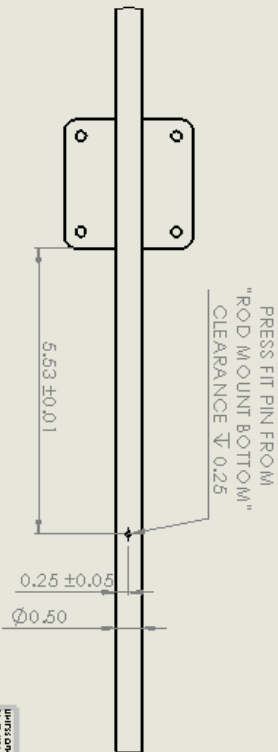
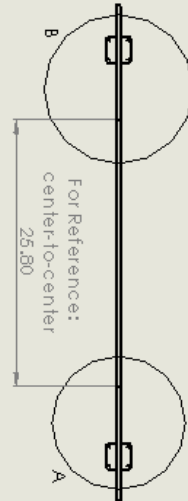

All Dimensions in Inches
PRESS FIT PIN FROM "ROD MOUNT BOTTOM" refers to pin size chosen
in other drawing. Not sure of the pin size, available in the shop

UNITS/COMPONENT PREFIX		TEMP		DIMS AND REFERENCE		DO NOT SCALE DRAWING		REVISED	
DESCRIPTION	UNIT	DESCRIPTION	UNIT	DESCRIPTION	UNIT	DESCRIPTION	UNIT	DESCRIPTION	UNIT
DATE	DATE	DATE	DATE	DATE	DATE	DATE	DATE	DATE	DATE
BY	BY	BY	BY	BY	BY	BY	BY	BY	BY
CHKD	CHKD	CHKD	CHKD	CHKD	CHKD	CHKD	CHKD	CHKD	CHKD
APP'D	APP'D	APP'D	APP'D	APP'D	APP'D	APP'D	APP'D	APP'D	APP'D
Q. A.	Q. A.	Q. A.	Q. A.	Q. A.	Q. A.	Q. A.	Q. A.	Q. A.	Q. A.
MATERIAL:					PART LOT:				
UNCLP					SCALE 1:1				

CF tube with mounts³

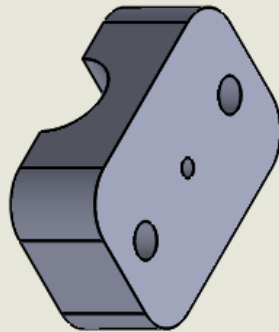
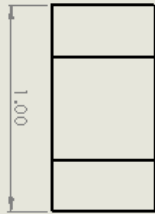
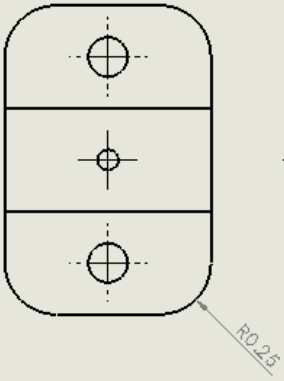
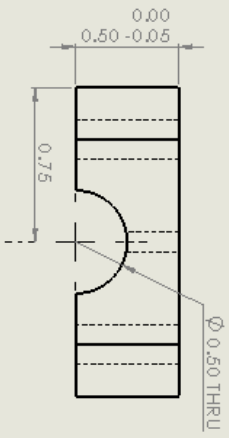
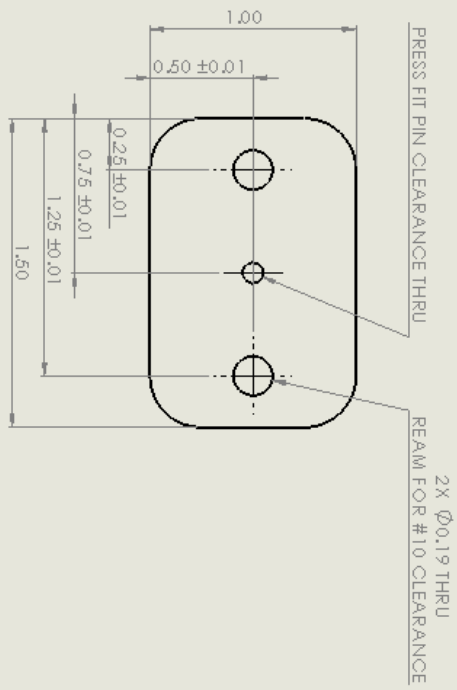

All Dimensions in Inches

UNITS/CONVERT FACTOR	INCH	MM	FEET	METERS	DIAMETER	LENGTH	WEIGHT	DATE	BY	CHKD	APP'D	Q. A.
DATE												
APP'D												
Q. A.												
Design Rod mount bottom 33 2017-10-11												

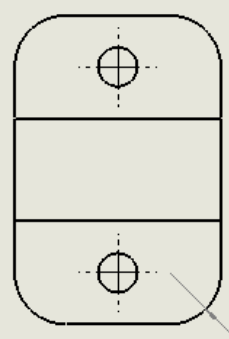
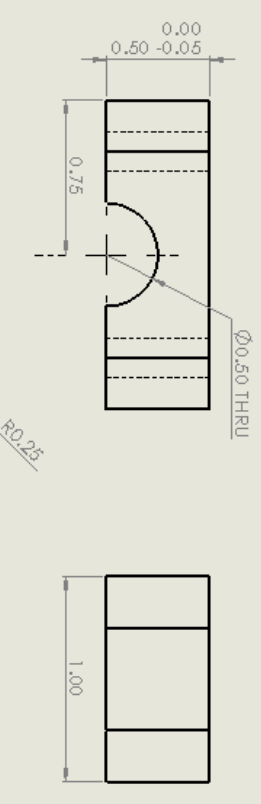
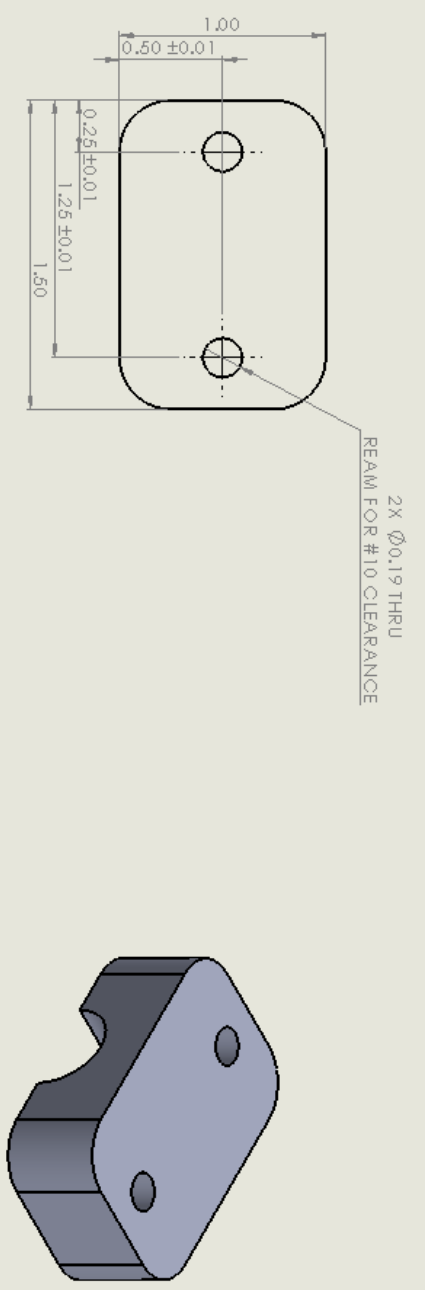

All Dimensions in Inches

UNITS OWNER	SHEET	DATE	BY	CHKD	APP'D	DATE	DESCRIPTION
<div style="display: flex; justify-content: space-between;"> <div> <p>DATE: 03/20/2014</p> <p>TIME: 10:00 AM</p> <p>BY: K. MURPHY</p> <p>CHKD: J. B. BROWN</p> <p>APP'D: K. MURPHY</p> </div> <div style="text-align: center;"> <p>ROD MOUNT TOP</p> <p>ROD MOUNT TOP</p> <p>ROD MOUNT TOP</p> </div> <div> <p>DATE: 03/20/2014</p> <p>TIME: 10:00 AM</p> <p>BY: K. MURPHY</p> <p>CHKD: J. B. BROWN</p> <p>APP'D: K. MURPHY</p> </div> </div>							
<p>ROD MOUNT TOP</p>						<p>DATE: 03/20/2014</p> <p>TIME: 10:00 AM</p>	<p>BY: K. MURPHY</p> <p>CHKD: J. B. BROWN</p> <p>APP'D: K. MURPHY</p>

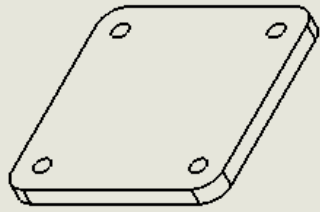
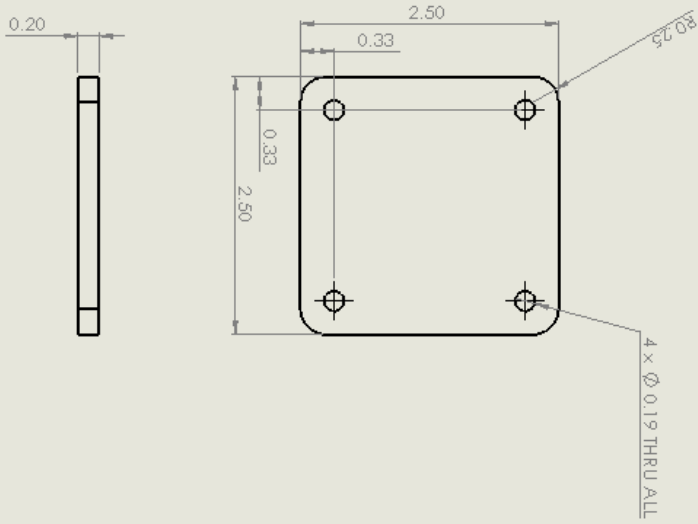

All Dimensions in Inches

UNITS/OWNER/SECTION		DATE	DRAWN AND RECHECKED		DATE	BY
DESIGN	DATE	SCALE	DATE	BY		
APP'D						
CHK						
Q.A.						

PROJECT: motor mount bottom
 SHEET: 1 OF 1

APPENDIX B FMEA

Component	Function	Failure Mode	Failure Effect	Severity	Potential Failure Causes	Occurrence	Preventative Action	Detection Action	Detection	RPN	Recommended Actions	Who's Responsible?	Action Taken
1. DC Motors	Provided rotational motion of propellers	DC Motor burned out	Unable to fly	7	Surpass maximum current rating Extended time above 80% power	2	Watch power load on motors Watch power load on motors	Monitor active load on motors Monitor time and load on motors	2	28			
2. G10 Motor mounts	Attachment of motors to carbon fiber rods	Epoxy fails	Damage motors, props, or plane	9	Crash landing Extended use of epoxy	3	Bolt motor mounts around CF tube	Manually attach	2	54	Ensure Machine shop drills holes correctly into CF rods	Chris	Ensured by Machine shop holes could be drilled and kept vertical
								Attach to testing	2	18			
								Material selection	4	36			
3. CF tubes	Attachment of motors to base	CF tubes fracture	Damage motors, props, or plane	9	Fatigue of tubes Crash landing Large shear stresses created	2	Material selection	Visual	4	72			
								Attach to testing	2	18			
								Material selection	4	72			
								Material selection	4	72			
4. Aluminum Rods	Attachment of CF tubes to base	Aluminum rods fracture	Damage motors, props, or plane	9	Crash landing Vibrations Large moments from AL rods Tear out failure of bolts	1	Material selection	Visual	4	36			
								Washers and	4	72			
								Material Selection	4	72			
								Material selection	4	72			
5. Wood Base	Attachment of aluminum rods to base	Wood Base Fracture	Damage motors, props, or plane	9	Crash landing Vibrations Large moments from AL rods Tear out failure of bolts	1	Material selection	Manually attach	2	18			
								Attach to testing	2	18			
								Material selection	4	72			
6. APM	Microcontroller to control all aspect of plane	Loss of connection to controller	Loss of connection to controller	8	Poor GPS Mount	1	Material selection	Visual	2	16			
								Charge Battery/ESC	1	45			
								Material selection	4	108	Use Mission planner to track vibration	Gavarni and Jermaine	Observe while testing
7. ESC's	Speed controllers for DC motors	Speed controls loose power	Damage motors, props, or plane	9	ESC burns out Loose connection to power supply	2	Material selection	Visual	4	72			
								Charge Battery/ESC	1	45			
								Material selection	4	108			
8. Plane Flaps	Used to control plane	Flaps fail to operate	Damage motors, props, or plane	9	Servo motors do not operate properly	3	Material selection	Visual	4	72			
								Charge Battery/ESC	1	45			
								Material selection	4	108	Use Mission planner to track vibration	Gavarni and Jermaine	Observe while testing
9. Plane Flaps	Used to control plane	Flaps fail to operate	Damage motors, props, or plane	9	Servo motors do not operate properly	3	Material selection	Visual	4	72			
								Charge Battery/ESC	1	45			
								Material selection	4	108	Use Mission planner to track vibration	Gavarni and Jermaine	Observe while testing

APPENDIX C GANTT CHARTS

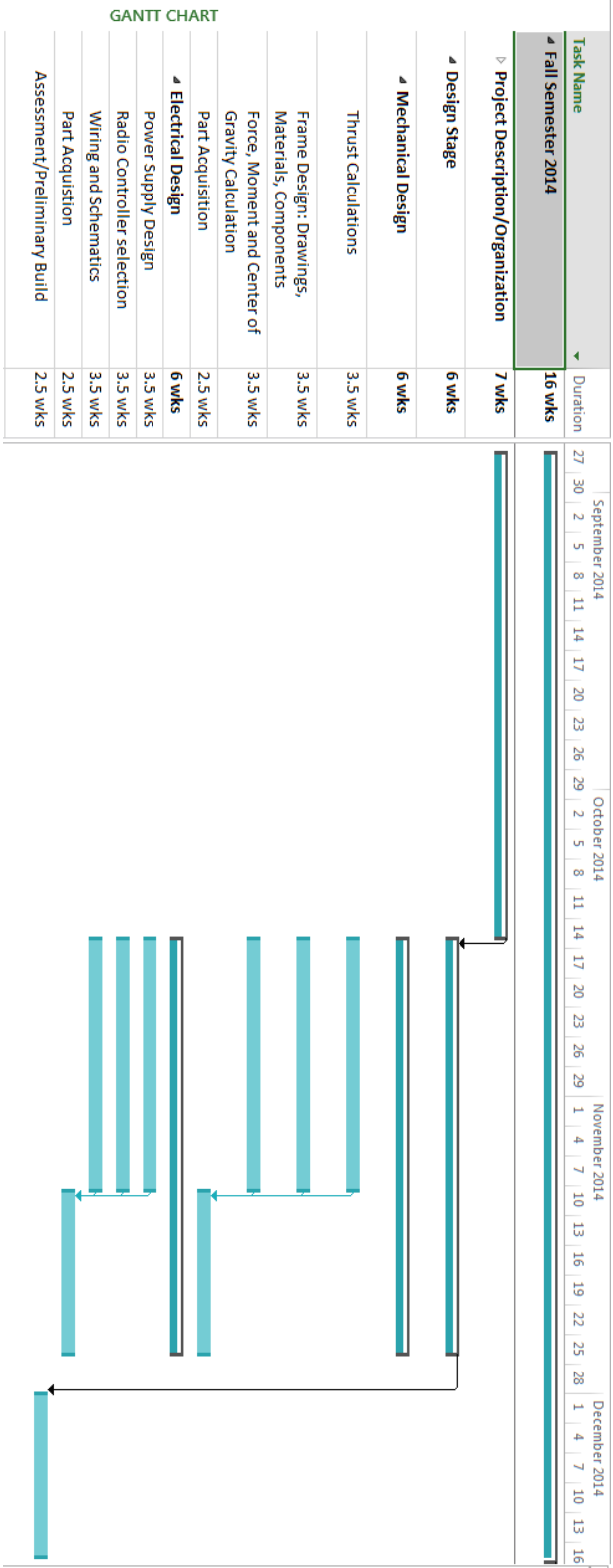

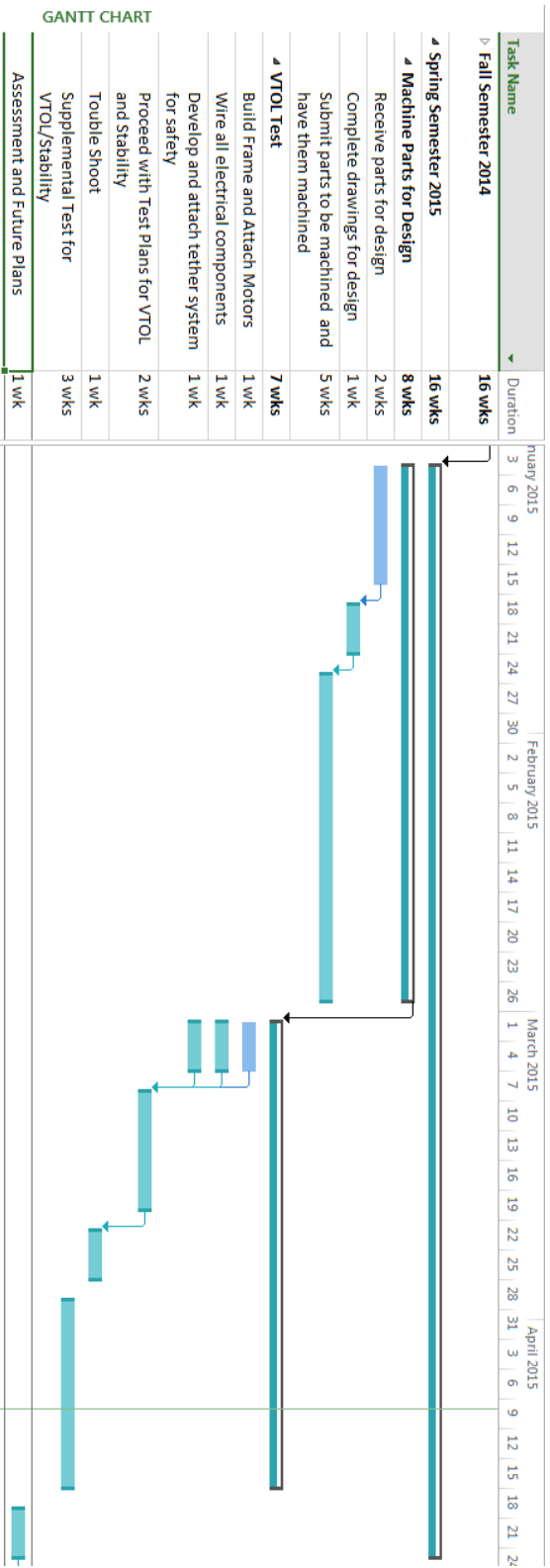

WBS CHART

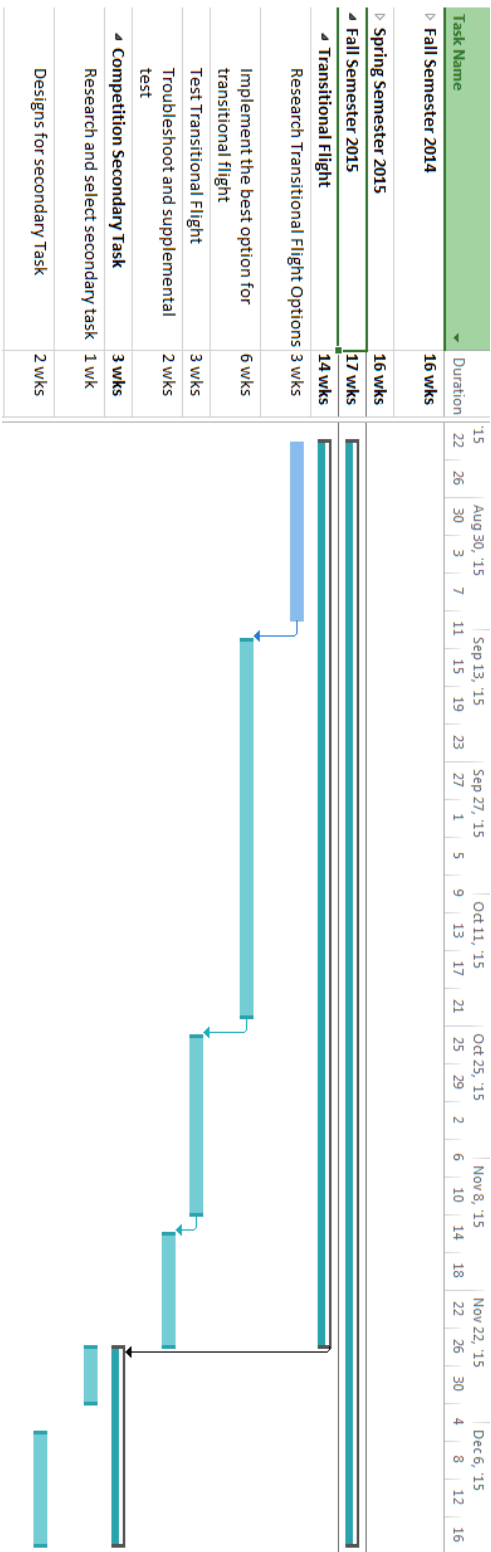

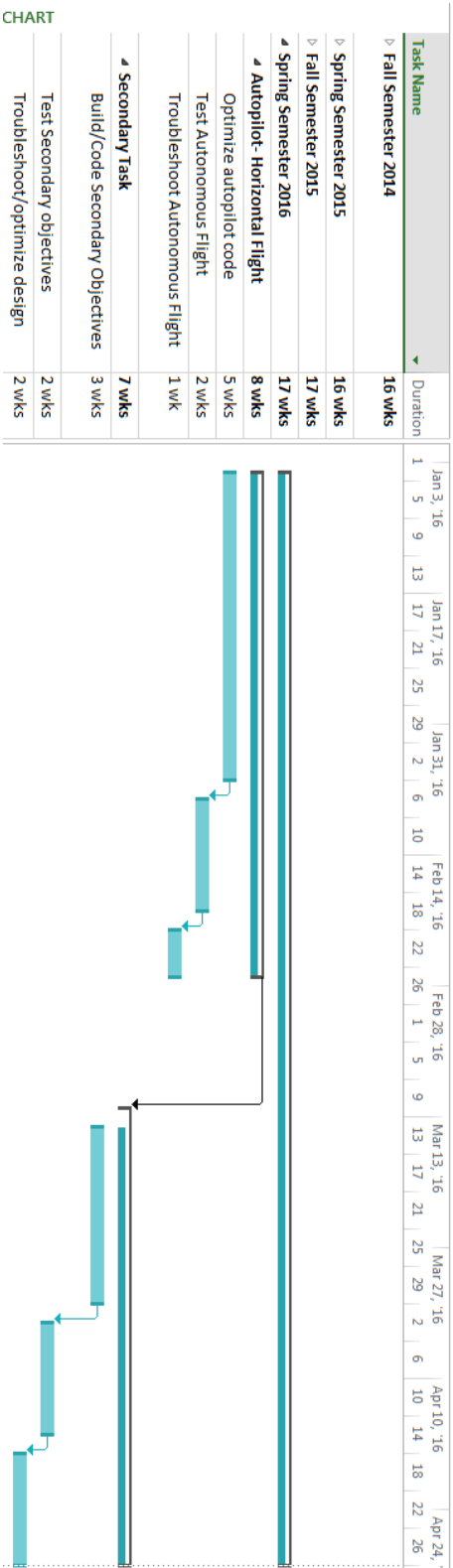

CHART

BIOGRAPHY

David Hegg (Group Leader):

David Hegg is a Mechanical Engineering student from Florida State University. His area of interest is in the aerospace industry where he is currently a research assistant at the Florida Center for Advanced Aero-Propulsion. David has also interned at Arthrex and at Gerdau over the past two summers.

Christopher Bergljung (ME Lead):

Christopher Bergljung is a Mechanical Engineering student from Florida State University. This fall Christopher took part in the FIPSE study abroad program at UNIFEI in Itajuba, Brazil. Christopher has also interned three summers in Sweden. His experience is in Marine Engineering with a focus on non-destructive testing and product safety.

Jermaine Dickey (Programming Lead):

Jermaine Dickey was born and raised in Tallahassee. His interests are in Mechatronic Controls. Jermaine is employed with the National High Magnetic Field Lab as a student researcher studying superconducting magnets. As a senior at the College of Engineering, he has almost reached his dream of becoming a Mechanical Engineer.

William Di Scipio (Secretary):

William Di Scipio is a fourth year Mechanical Engineering student. He has developed his passions and expertise for aerospace and dynamic systems. Furthermore, he has been involved in several organizations, such as SAE, AIAA, and FCAAP. He further ensures his professional development by working at a Fortune 500 company.

Gavarni Leonce (EE Lead):

Gavarni Leonce is an Electrical Engineering student from Florida State University. As one of two electrical engineers on Team 8, Gavarni has a large role in the project. Gavarni is also interested in software engineering. Upon graduation, he will study for another year to acquire a degree in computer engineering.

John Murnane (Web Designer):

John Murnane is a Mechanical Engineering student from Florida State University. John took part in the FIPSE study abroad program in Fall of 2014, studying at UNIFEI in Itajuba, Brazil. Over past summers, John has had five consecutive internships with a medical manufacturing company; gaining irreplaceable real-world experience.

Tavarius Slaughter (Treasurer):

Tavarius Slaughter is an Electrical Engineering student from Florida State University. He has interned for a Fortune 500 company, PPL Corporation, as a transmission design engineer. Tavarius also works two jobs, he is the Keeper of Finance of Omega Psi Phi Fraternity incorporated, and an active mentor in the community.