

# Bi-directional Offset Lifting Bar

---

## Midterm Report



### Team 5

Devin Stubbs	drs10f
Coert Maraist	csm11d
Luke Leelum	lj110
Yoel Bugin	yb12f
Gabriel Omoniyi	goo14

Submitted October 24, 2014

Dr. Gupta and Dr. Helzer

# Table of Contents

<b>Abstract</b> .....	<b>iv</b>
<b>1 Introduction</b> .....	<b>1</b>
<b>2 Project Definition</b> .....	<b>2</b>
2.1 Background Research.....	2
2.2 Need Statement .....	3
2.3 Goal Statement & Objectives.....	3
2.4 Constraints.....	4
<b>3 Design and Analysis:</b> .....	<b>5</b>
3.1 Functional Analysis.....	5
3.2 Design Concepts.....	5
3.2.1 Counterweight.....	5
3.2.2 Two Points of Lift.....	6
3.2.3 Redirection of Lift.....	7
3.2.4 Redesigned Gantry System.....	8
3.3 Evaluation of Designs .....	11
3.3.1 Criteria, Method.....	11
3.3.2 Selection of Optimum Designs .....	11
<b>4 Methodology</b> .....	<b>14</b>
4.1 Schedule .....	15
4.2 Resource Allocation .....	16
<b>5 Conclusion</b> .....	<b>18</b>
<b>6 References</b> .....	<b>19</b>
<b>7 Appendix A - Gantt Chart</b> .....	<b>20</b>
<b>8 Appendix B - Drawings</b> .....	<b>21</b>

## Table of Figures

Figure 1 - Schematic of Turbocor's new VTT Compressor showing center of mass location .....	2
Figure 2 - CAD Drawing of the Counterweight Lifting Bar Concept .....	5
Figure 3 - CAD Drawing of the Two Points of Lift Concept .....	6
Figure 4 - CAD Drawing of the Redirection of Lift Concept.....	7
Figure 5 - Picture of the current gantry and crane hoist .....	8
Figure 6 - (a) Front view of the CAD drawing (left), (b) dynamic perspective showing the components of the trolley system (right). .....	9
Figure 7 - CAD drawing of the proposed adjustable lifting bar, utilizing a power screw .....	9
Figure 8- Load analysis on the redesigned gantry from a 2000 lbf load .....	13
Figure 9 – Load analysis on the lifting bar .....	13
Figure 10 - Flow Diagram of the design process .....	15
Figure 11 - Gantt Chart .....	20
Figure 12 - Lifting Bar Drawing.....	21
Figure 13 – Power Screw Guide Block Drawing.....	21
Figure 14 - Channel Block Drawing .....	22
Figure 15 - I-beam for Gantry System Drawing.....	22
Figure 16 - Gantry Support Plate Drawing .....	22
Figure 17 - 5" Caster Drawing .....	22

## Table of Tables

Table 1 - Decision matrix of the four designs.....	11
--	----

## Abstract

Having a swift plan of action for a design project of this caliber is paramount in completing the objective in a timely manner. The goal of this project is to implement a method to lift Danfoss Turbocor's next generation VTT compressor into testing position in their Chiller 3 system. In order to accomplish this goal, Team 5 has met with Turbocor several times to consult with the engineers involved and to establish a strong working relationship. The original request was for Team 5 to develop an offset lifting bar to lift their half ton compressor. However, after conceptualization of numerous designs and continuous consultation with Turbocor, Team 5 proposes to increase the vertical lifting height of the compressor by redesigning the current gantry system and developing a separate lifting bar. Turbocor has been supportive of the team's progress and has assured Team 5 of full financial sponsorship.

# 1 Introduction

Danfoss Turbocor has asked Team 5 to devise a new method to lift their new compressor to the testing height using the existing crane hoist and gantry system. This must be executed in a manner that is safe and reliable, but not require a new process to achieve the goal.

The current gantry system is designed to lift the compressor to a height at which was adequate for previous compressor models, but does not lift the new compressor to the appropriate height for testing. As a temporary solution, Turbocor has implemented the use of a manual chain hoist in order to lift the compressor to the appropriate height. This method is unsatisfactory, thus Turbocor has sought out alternative methods, which must be feasible within the following constraints. Safety is the most important aspect due to the potential risk to human life and expensive equipment. The most challenging limitation is the working space of the room, which will be a deciding factor in choosing a concept.

## 2 Project Definition

### 2.1 Background Research

*“Danfoss Turbocor Compressors are transforming the commercial HVAC market with innovative technology that redefines lifetime operating costs for mid-range chiller and rooftop applications.” [1]*

Before every compressor is approved for distribution, it must be tested on a chiller rig to test for its efficiencies and performance. Turbocor now has a new line of compressors, the VTT line, which is much larger and operates at higher pressures than previous models. Due to the high confidentiality of this compressor, background research has been obstructively difficult. The compressor at hand is shown below in Figure 1, which has been a primary source of information about the compressor due to this confidentiality. The gantry system and lifting bar are custom, thus there is no literature related to them.

Currently, Turbocor has implemented a temporary solution that requires the assistance of multiple mechanical engineers in order to manually lift the half-ton compressor over six feet to be installed on to the chiller testing rig. This procedure is hazardous and distracts the engineers from projects that require their attention. Team 5 has been asked to develop a solution in order to create a safer working condition and allow the compressor to be lifted in to place without the supervision of any more mechanical engineers than are necessary.

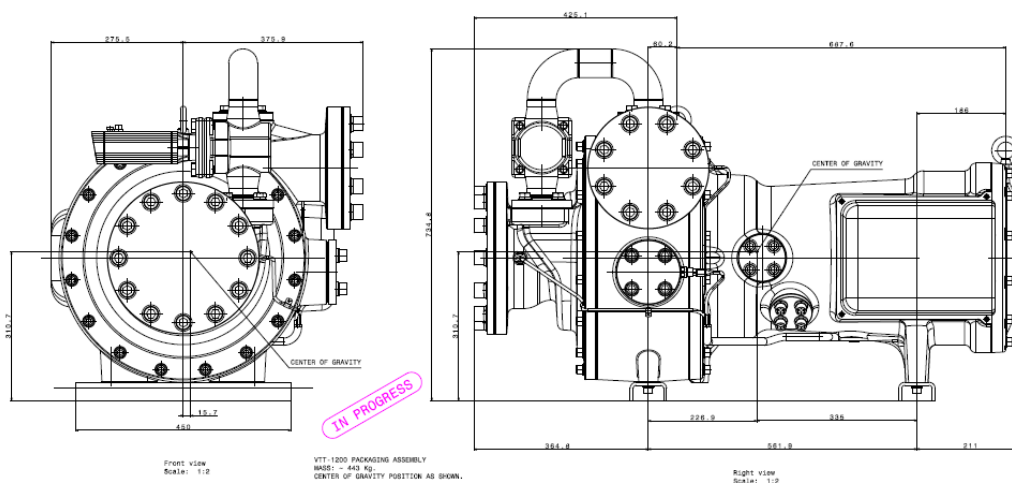

**Figure 1 - Schematic of Turbocor's new VTT Compressor showing center of mass location**

## 2.2 Need Statement

Danfoss Turbocor requires that each half-ton compressor be tested on the chiller system to ensure quality control. Each time the new compressor is ready for testing, a mechanical engineer must employ the use of a manual chain hoist to lift and install the compressor onto the chiller system. Danfoss Turbocor has sponsored a team of 5 mechanical engineering students to solve this problem. Currently, Team 5 is in the process of routinely meeting with Turbocor to discuss project progress. During these meetings, Team 5 presented risk assessments, detailed project specification, project plan, and proposed design concepts. After these documents were reviewed, Team 5 proposed an alternative design solution that does not implement the use of an Offset Lifting Bar, but does raise the compressor to a sufficient vertical distance.

*“The current lifting process requires too much manual labor and distracts an engineer from tasks that he could else wise be focusing on.”*

## 2.3 Goal Statement & Objectives

*“A better lifting system must be designed and implemented in order to more easily install the compressor for testing.”*

### Objectives:

- Increase lifting height of the compressor
- Must be able to adjust for a variation in center of gravity of the compressor being lifted
- Lifting system must be compatible with multiple compressors
- Minimize all safety risks involved with lifting a half ton compressor
- Design must not interfere with current production practices

## 2.4 Constraints

- Adjustable Point of lift for a variation in Center of Gravity
- Adjustable lifting hooks (dx = 18" to 38")
- Must be OSHA regulation compliant
- Primary load capacity: 1200 lb
- Maximum operating weight (unloaded): 500 lb
- <\$1000 Provided by Danfoss Turbocor
- Limited access to the compressor and chiller due to confidentiality
- Extremely constricting dimensions available for compressor/lifting arm movement



## 3 Design and Analysis:

### 3.1 Functional Analysis

For this project to be considered a success, a few minimum standards must be met: must be able to safely lift a half ton compressor to an increased overall height and adjustment of lifting point for a variation of center of gravity. When designing the following concepts, these requirements were kept in careful consideration. Safety was of the utmost concern, but the performance of each design is absolutely necessary.

### 3.2 Design Concepts

#### 3.2.1 Counterweight

The initial goal of this project was to lift the compressor from a location that was offset vertically and horizontally from the two points of lift on the compressor. It did not take much analysis to realize this would result in a large moment caused by the center of gravity of the compressor. Thus, the concept of utilizing a counterweight in order to counterbalance the moment induced by the center of gravity of the compressor was introduced. Turbocor set a constraint of 500 lbs in total weight of the lifting bar. This meant that the distance of the point of lift to the center of gravity of the counterweight lifting bar had to be roughly twice that of the distance from the lifting point to the center of gravity of the compressor (~70 cm). A 3-D model of the counterweight lifting bar is shown below in Figure 2.

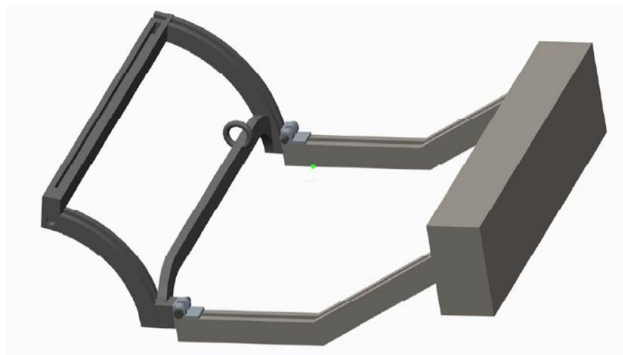
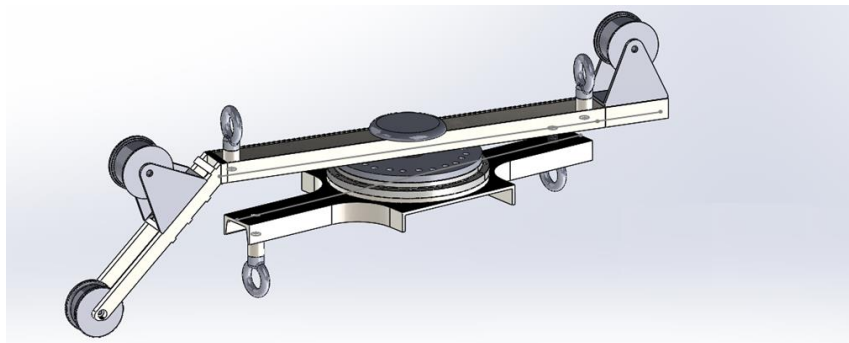

**Figure 2 - CAD Drawing of the Counterweight Lifting Bar Concept**

When taking this design into consideration, Team 5 made sure not to overlook the safety of the operator and the tight working conditions in the chiller rig. It would cause a hazardous working condition to have a 500 lb. counterweight extended at over two feet from a compressor that weighs a half ton. Additionally, there is sensitive and expensive equipment in the chiller rig. There is a large risk in damage if a 500 lb. counterweight were to swing around and collide with any of this sensitive equipment. The cost of the raw material had to be taken into account as well. In order to minimize the size of the counterweight, a very dense material would need to be used, such as tungsten, which would be very expensive with a scrap price of roughly \$20 per pound.<sup>4</sup> If the counterweight was to be made out of cheap steel, instead of Tungsten, in order to reduce cost, this would result in a much larger counterweight which could be detrimental for the tight working conditions. Furthermore, there was no clear solution as to how this lifting bar could be adjusted to account for a variation in center of gravity of the compressor being lifted.

### 3.2.2 Two Points of Lift

In addition to the counterweight design, Team 5 devised a way to lift the compressor without the use of a counterweight. This design utilizes a cable and pulley system in order to increase the lifting height of the compressor, which is shown in Figure 3. The higher pulley (on the right in Fig. 3) would redirect the cable to a fixed location on the gantry system and the lowest pulley (on the left in Fig. 3) would redirect the opposite end of the cable to the crane hoist. An issue with this design is the lack of rotation allowed by the lifting bar due to the fixed point of lift and so a turntable would be utilized for rotation of the compressor, which can be seen in the figure.

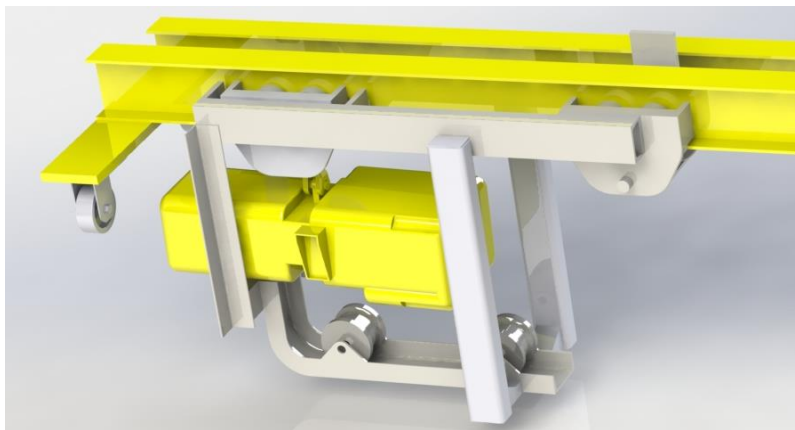

**Figure 3 - CAD Drawing of the Two Points of Lift Concept**

When taking this design into consideration, key factors such as safety, performance, and cost stuck out the most. Safety is the number one goal of an engineer when finding the solution to a problem. For this design, the amount of moving parts and multiple pulleys concentrate points of possible failure and it was crucial that these components were engineered perfectly in order to prevent this. In addition to the safety concerns, there were concerns with the performance of the design. For one, this design requires a fixed point of lift on one side of the cable, requiring that one side of the lifting bar would be in a fixed horizontal location. The turntable is also subjected to torquing due to any alteration of the center of gravity of the compressor, which is completely unacceptable. In addition to the performance of the turntable, models that are rated for the loading this lifting bar will be subjected to are upwards of \$750, which is three-fourths of the budget.

### 3.2.3 Redirection of Lift

Team 5 understood the true issue at hand was to be able to lift the new VTT compressor to a larger vertical distance and this could be achieved by redirecting the point of lift to a higher point than the crane hoist is capable of. This redirection of lift could be achieved by the use of a pulley system, which can be seen below in Figure 4. The two lower pulleys would be used to redirect the chain horizontally away from the crane hoist, and the third pulley situated at the trolley on the right hand side would redirect the chain to a higher point.



**Figure 4 - CAD Drawing of the Redirection of Lift Concept**

Team 5 felt this design was a very strong candidate and could possibly be the solution that Turbocor is looking for. This redirection of lift is simple, effective, and came within the budget set by Turbocor. However, Team 5 ultimately rejected this design, for reasons following.

This redirection of lift itself was affordable, but would require the design and manufacturing of a separate lifting bar that could adjust for a variation of center of gravity. This separate lifting bar would evidently reach beyond the scope of the budget. There is also a risk of failure concentrated at each pulley location due to the dynamic loading each pulley would experience. This design also required that a steel frame would be enclosing the crane hoist, as can be seen in the figure. This would cause a hazard for any personnel to hit their head while walking below the crane hoist. With the above points taken into consideration, Team 5 collaborated to conceptualize a solution that had fewer drawbacks.

### 3.2.4 Redesigned Gantry System

In order to increase the lifting height of the compressor a concept to redesign the current gantry system and suspend the crane hoist between the two I-beams became the focus of the team's attention. Seen below, in Figure 5, a picture of the current gantry and crane hoist system can be seen.

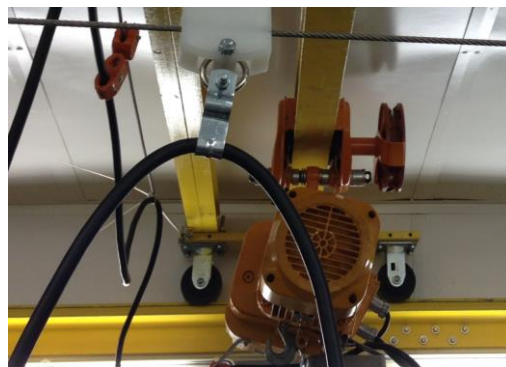

**Figure 5 - Picture of the current gantry and crane hoist**

As can be seen in the above figure, the current crane hoist is suspended below one of the I-beams and there is a substantial gap between the top of the hoist and bottom of the I-beam. Consequently, there is a large amount of wasted space between the hook of the crane hoist and the bottom of the I-beam. This led Team 5 to the solution of increasing the crane hoist height to increase the overall lifting height of the compressor. The conceptual model of this solution is shown below in Figure 6. Drawings for the lifting bar and gantry system can found in Appendix B.

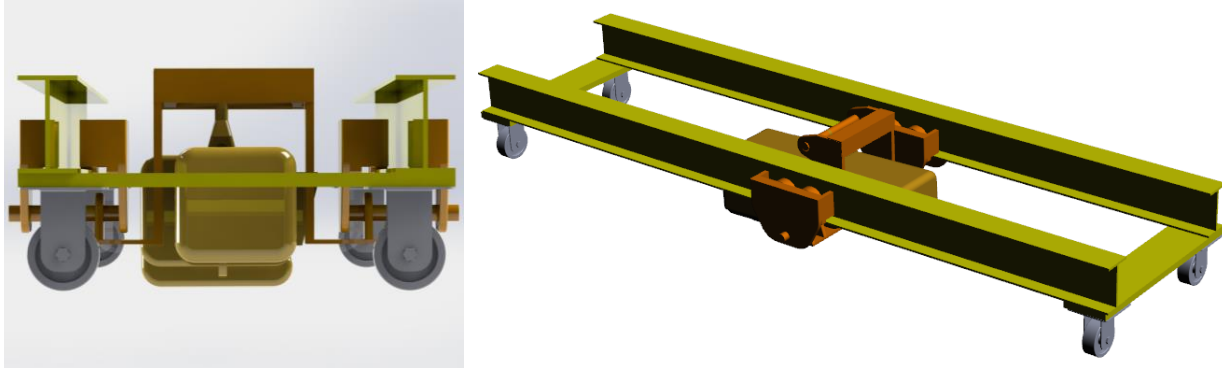

**Figure 6 - (a) Front view of the CAD drawing (left), (b) dynamic perspective showing the components of the trolley system (right).**

As can be seen in the above figure, the redesigned gantry requires the implementation of a trolley system that suspends the hoist between the two I-beams. In Figure 6a, the increase in vertical height from the current system can clearly be seen. Through stress analysis, Team 5 has determined this designed to be safe and reliable. This redesigned gantry does not result in any additional hazards that are not already present in the chiller rig (unlike that of the redirection of lift design) and has a high level of durability. There are two major drawbacks with this design: the total cost and the need for a secondary lifting bar. Team 5 met with Turbocor to discuss this design and the sponsor was so pleased with the ingenuity of the team that Turbocor has allowed for an increase in the budget as long as all spending requirements are presented to Turbocor with justification of need. Thus, as long as Team 5 is mindful of keeping costs to a minimum, there should not be any budgetary issues. In addition to the redesigned gantry system, Team 5 has devised a lifting bar that is adjustable to account for a variation in center of gravity. The proposed lifting bar is shown below, in Figure 7.

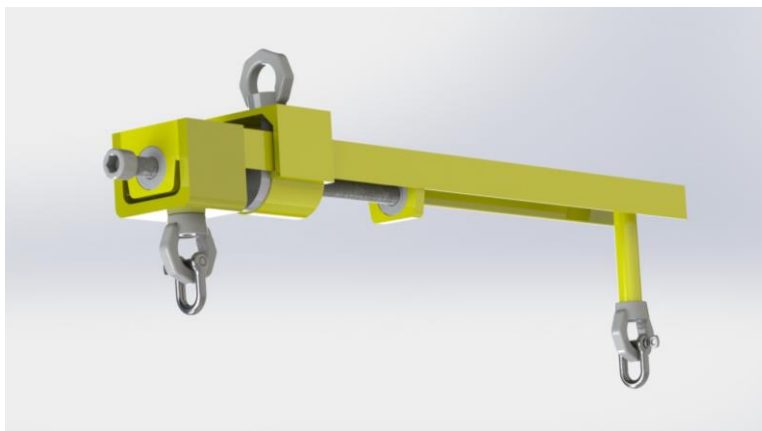

**Figure 7 - CAD drawing of the proposed adjustable lifting bar, utilizing a power screw**

This lifting bar was essentially designed from the current lifting bar being used by Turbocor, with the exception of the variable point of lift for a variation of center of gravity. The power screw, located inside the C-channel of the lifting bar, is used to translate the lifting hook along the axis of the lifting bar and will be adjusted manually. The point of lift, represented by the eyebolt assembly, will be designed in such a way that the load of the compressor is felt by the C-channel itself and not by the power screw. Bearings will ensure ease of movement of the power screw and will also be used to reduce friction between the eyebolt assembly and the lifting bar. These linear bearings will also support the load of the compressor as to relieve any loading on the power screw itself.

Due to the moving parts of this lifting bar, it is crucial that Team 5 designs this bar with the utmost engineering practices. It is imperative that the power screw experiences only axial loading and that the bearings between the lifting assembly and the C-channel are rated for the proper amount of loading. All components purchased from a vendor will be required to have a Factor of Safety (F.S.) of at least 1.5 for the load experienced by the lifting bar. Any components that are machined by the team will be load tested upon completion of prototyping with a F.S. of 1.25 (per OSHA requirements<sup>5</sup>)

A necessary component of this design is the need for a redesigned trolley system that can suspend the crane hoist between the two I-beams, which can be viewed in Figure 6. At this point in the design process, Team 5 has not yet finalized a design for this redesigned trolley. The visual representation in Figure 6 is simply a proof of concept and the final trolley design is in process. However, Team 5 is aware of the immense stresses that this trolley will endure and so the materials chosen and their dimensions will be of the utmost importance. Also, it is imperative that this trolley remains square on the gantry system and so Team 5 will need to devise a mechanical aperture in order to achieve this. The low overhead clearance above the gantry system due to the ceiling of the chiller room will also be very important to consider when designing this trolley. It is crucial that the trolley and/or crane hoist never come into contact with the ceiling, and so a compact trolley design will be the most effective.

## 3.3 Evaluation of Designs

### 3.3.1 Criteria, Method

When deciding which of the previously mentioned designs would be selected, Team 5 mainly focused on the safety of the operator and the performance of the design, followed by the cost involved. The ease of implementation and durability of the design were also very important to consider, but the constraints of the project deemed these to be less important. A visual representation of how each of the four designs ranked among the five categories is shown below in the form of a decision matrix in **Table 1**. Each of these scores were ranked out of a score of ten. Durability had the lowest factor in the decision making process because factors such as being able to implement the design and minimizing the cost of the design were more important to the scope of the project.

**Table 1 - Decision matrix of the four designs**

<b>Design</b>	<b>Safety (30%)</b>	<b>Performance (25%)</b>	<b>Cost (20%)</b>	<b>Implementation (15%)</b>	<b>Durability (10%)</b>	<b>Total</b>
Counterweight	2	5	3	6	6	3.95
Two Points of Lift	4	6	1	3	5	3.85
Redirection of Lift	6	9	6	6	7	6.85
Redesigned Gantry	9	9	5	8	9	8.05

### 3.3.2 Selection of Optimum Designs

The Redirection of Lift and Redesigned Gantry designs became the primary focus of Team 5. The decision matrix demonstrates this in a quantifiable way, with these two designs having the highest weighted score. Team 5 found that two offset lifting bars had too many drawbacks and were not surprised by the results of the decision matrix. When it came to the decision between the Redirection of lift and Redesigned Gantry, feedback from Turbocor and the

safety of the operator were heavily considered. For reasons previously discussed, the Redirection of Lift design could cause potential hazards for the personnel working around the crane hoist and gantry. Thus, the Redesigned Gantry was chosen to be the safer of the two choices. When these ideas were presented to Turbocor, they were retentive to both ideas. It was clear, however, that they were much more open to the idea of redesigning their current gantry system. Turbocor agreed with our concerns about the safety issues related to the redirection of lift and were open to increasing the budget if necessary for redesigning the current gantry system. Thus, taking all of this into consideration, Team 5 decided to move forward with the project focusing on redesigning the gantry system and developing a separate lifting bar.

Stress analysis was also performed on the redesigned gantry and lifting bar concepts in order to ensure that the materials and design selected would be able to withstand the dynamic loading involved with raising and lowering the compressor. Additionally, a F.S. of 2 was used in this stress analysis so a total force of 2000 pounds was applied to the different components.

Below, in Figure 8, is a visual representation of how the I-beams would react under the immense loading. The red points at the center of the I-beam can be considered where the trolley system would be located and the load would be concentrated, which is where the beams would experience the most stress. The color spectrum depicts the deflection the beam experiences (red being the most and violet being zero). Where the 2000 pound force is located, the beam experiences less than 0.004 inches in deflection. This is the maximum deflection the beam will ever experience considering it is at the center of the beam and furthest from either support location. After this analysis, the redesigned gantry has been confirmed to be a viable solution. Loading analysis has not yet been performed on the redesigned trolley because Team 5 is still in the initial stages of finalizing this design, which was previously discussed.



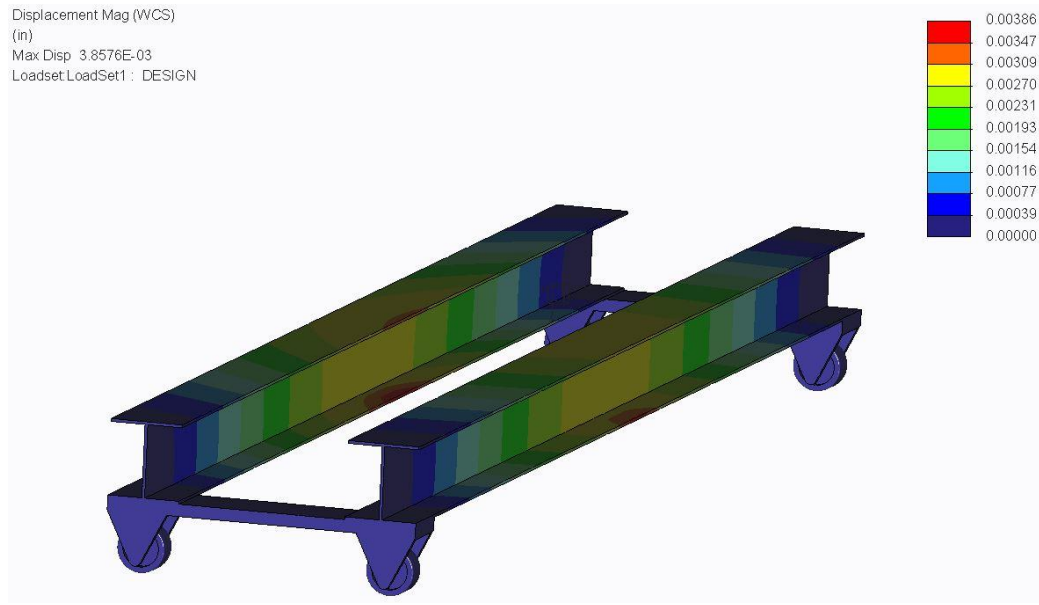

**Figure 8- Load analysis on the redesigned gantry from a 2000 lbf load**

In addition to doing preliminary load analysis on the new gantry, Team 5 completed load analysis on the lifting bar and power screw knuckle, which can be seen below in Figure 9. The lifting bar was designed in such a way that the power screw is to experience no loading other than the axial load from turning the screw. Thus, the load analysis was performed on only the bar itself and loading was fixated at the locations where the material would be experiencing a load due to lifting the compressor. It was found through this analysis that tear out failure is of the most concern for the design. Using a stronger material for the bar and implementing the use of washers to increase the surface area where the tear out could occur will mitigate this risk.

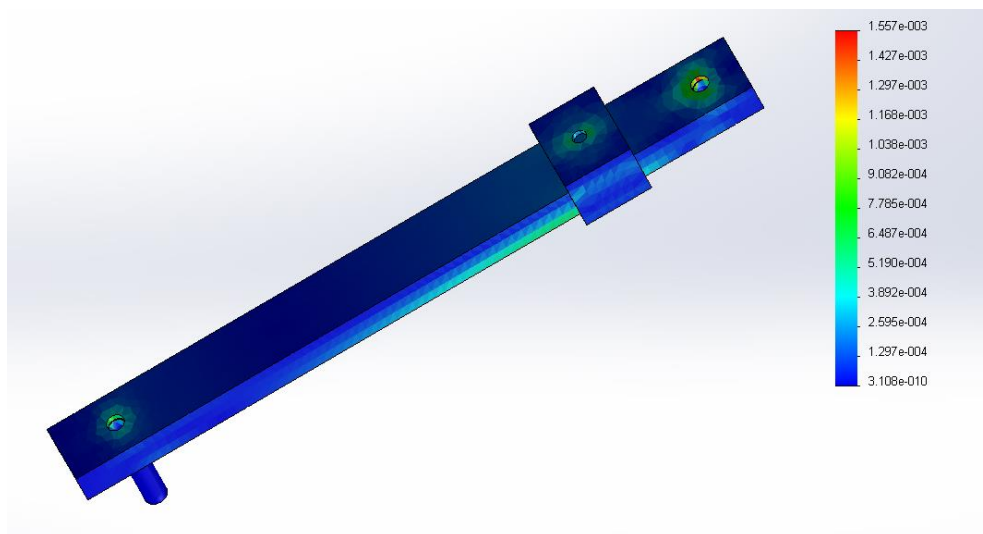

**Figure 9 – Load analysis on the lifting bar**

## 4 Methodology

The first step in the project plan was to begin communication with Turbocor in order to facilitate a good working relationship. An initial meeting was scheduled on Wednesday, September 10, in order to discuss the preliminary constraints of the project and to visit the task at hand in person. Team 5 was allowed access to Chiller 3 system and was able to better understand the difficulty of the project. We then scheduled a meeting that Friday, September 12th, in order to take measurements of the chiller. Turbocor shut down testing for two hours to allow us to do so.

Since those two preliminary meetings, the team has met weekly in order to discuss possible design implementations, budgetary constraints, and formulate a project timeline. On Friday, September 26, the team met with the team Advisor, Dr. Hollis, in order to discuss the team's possible designs and for new design suggestions. Team 5 will continue to meet every Monday at 4:00 pm and on alternating Tuesdays with Dr. Gupta and Dr. Helzer. Starting the second week of October, Team 5 will meet with Turbocor bi-monthly in order to maintain strong communication and to meet Turbocor's desired deadlines. Additionally, Team 5 maintains a relationship with Dr. Hollis for further assistance in the design and manufacturing of the project.

During the meeting that took place the second week of October, a complete project plan and timeline was discussed with Turbocor. Team 5 also presented four preliminary design prototypes and received positive feedback. The team is approaching this issue abstractly and proposed to dismiss the design and implementation of an offset lifting bar, and instead introduce a redesigned lifting bar that will complement the new gantry system. This method will require a larger budget and Team 5 has requested more funding in order to do so. Turbocor is pleased with the progress of the team thus far and has ensured that any spending requirements will be met with proper cost justification. In the third week of October, Team 5 met with Turbocor once again to review the progress of the project. An updated project plan was presented and the preliminary cost analysis of the redesigned gantry system was proposed. Turbocor has offered to allow Team 5 to utilize the company relationships with vendors in order to receive reduced cost of material and shipping.

At the next meeting with Turbocor, a final cost analysis of the redesigned gantry system using the pricing of the Turbocor vendors will be presented. A preliminary cost breakdown and

analysis will be presented for the new trolley system and lifting bar. Turbocor will provide feedback as to where costs can be minimized or where the team should be focusing their attention. By the conclusion of the semester, a final cost and FEM analysis will be completed of the gantry system, trolley, and lifting bar. Team 5 will present this analysis to Turbocor. Upon their approval of Team 5's decision, purchasing will begin at the start of the spring semester for prototyping.

When approaching the problem at hand, Team 5 was sure to use a dynamic methodology. This meant understanding the true goal of the project was to lift the compressor to a higher vertical distance. The method in which Team 5 achieved this is outlined below in Figure 10 as a flow diagram.

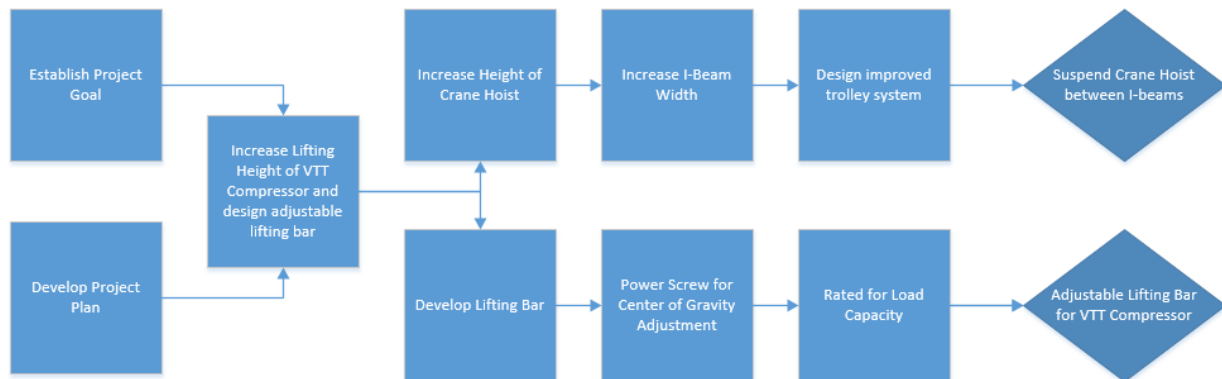

**Figure 10 - Flow Diagram of the design process**

## 4.1 Schedule

In order to ensure that Team 5 will meet required deadlines for the project, a project plan and schedule has been established. This project plan will be followed as closely as possible and when scheduling changes are necessary, the project plan will be updated. A visual representation of the current project plan can be viewed in the form of a Gantt chart, which can be found in Appendix A in Figure 11. This section will be referring to that Gantt chart. As can be seen, the schedule was broken into three major sections: Planning, Concept Creation, Design Proposal.

The Planning stage was very important. Team 5 first utilized this time period in order to delegate roles to each member and schedule routine meetings for the team. The team leader went over project deadlines and ensured all members were clear on their responsibility within the team in

order to create a cohesive work effort. As a team, a project plan was developed before any engineering was performed as to maximize the proficiency of the team. Team 5 then presented this project plan to Turbocor and moved on to the Concept Creation stage of the project.

To initiate the Concept Creation stage, all team members were required to produce a concept that could possibly be a solution for Tubocor's problem. Some members conceptualized multiple design solutions. The team then went over all of the concepts in order to rank each concept against one another. Team 5 then eliminated the ones that were obsolete until there were four remaining designs, which were discussed previously. The team then completed rough analysis on these designs, including FMEA, cost, and performance. How these designs ranked against each other was discussed in section 3.3. Team 5 then presented their design concepts to Turbocor and placed a heavy focus on their plan to redesign the gantry system. Turbocor provided positive feedback on the redesigned gantry system, Team 5 began to focus their attention on that design, and the Design Proposal stage began.

Currently, Team 5 is in the Design Proposal stage and is working on finalizing the design by completing initial FMEA (Failure Mode Effects Analysis) and assessing the risks Team 5 can foresee with this design. Completing these analyses prior to development will promote strong project progression and will be useful in mitigating any risks Team 5 may encounter in the future. At this point, Team 5 is in the middle of CAD modeling and had completed initial load simulation. Team 5 will then use these models to complete final CAD analysis and finish the analysis process with FEM analysis. Upon completion of the FEM analysis, if any changes need to be made to the design this will be done so. If not, the concept development will be finished and the project will be proposed to the sponsor once a comprehensive cost analysis is completed. This final proposal will initiate the prototyping stage in the spring semester, which is not illustrated on the Gantt chart.

## 4.2 Resource Allocation

The development and implementation of the improved gantry system with adjustable lifting bar requires several tasks that are dependent on each other in order for Team 5 to perform in an organized and efficient manner. Before any of these tasks could be completed, team member roles were assigned to each member, and their responsibilities within the team will be discussed in the paragraphs following.

Team Leader – Devin Stubbs  
Secretary – Coert Maraist

Financial Advisor – Luke Leelum  
Lead M.E. – Yoel Bugin  
Webmaster – Gabriel Omoniyi

As Team Leader, Devin will be responsible for maintaining a clear schedule and project plan, delegating responsibilities to each member and ensuring each member is held accountable for their responsibilities to the team. It will be Devin's responsibility to make sure all team members have the knowledge and resources necessary to complete any and all tasks assigned. The team leader will also be responsible for ensuring that clear project progression is being made and that all deadlines are met. Communication between Turbocor and advisors will be mostly through the team leader, but the secretary will also be of assistance. As the Secretary, Coert will be responsible for documenting the content of each team and sponsor meeting to warrant a clear understanding amongst team members. The secretary will also be responsible for making sure that all deadlines are met for each deliverable, staff meeting, and sponsor meetings.

As the Lead Mechanical Engineer, Yoel will be in charge of the design, development, and implementation of the project. He will work hand and hand with the team leader and financial advisor to make sure all project specifications are met and that the project stays within budget. If any budgetary changes must be made in order for fulfillment of the project, the team leader and the financial advisor must approve these changes. Additionally, it will be the Lead M.E.'s responsibility to ask for assistance and delegate tasks to all members of Team 5 if help is needed in meeting a deadline or with design.

As the Financial Advisor, Luke will not only be responsible for ensuring the project stays within budget, but will also facilitate communication with the sponsor regarding any purchasing of material. If the financial advisor approves a budgetary change that has also been approved by the team leader, it will be his responsibility to communicate with Turbocor the need for this budgetary change. As the Webmaster, Gabriel will be responsibility for the creation and upkeep of the team's website. As project progression is made, updates will be uploaded to the website so that all aspects of the project are transparent to the sponsor and advisors. Background information about the project and each team member will be provided on the website as to allow insight on the project at hand and who is in behind finding a solution to the problem at hand.

## 5 Conclusion

Turbocor is in need of a new lifting system in order to lift the new VTT compressor into place for chiller testing. The current gantry system was sufficient for previous compressors, but is inadequate for the new design. Turbocor has requested that a new, offset lifting bar be designed and implemented with the current crane hoist in order to lift the compressor to the appropriate height. Team 5 has proposed that, in order to safely solve this issue, a new gantry system be designed in order to suspend the crane hoist between the I-beams and also develop a lifting bar that will be able to adjust for a variation of the center of gravity for each compressor. Turbocor has shown full support of this proposal and Team 5 plans to have a complete development of the design in the upcoming weeks.

## 6 References

- [1] "OEM Customers." *Danfoss Turbocor Compressors Inc.* N.p., n.d. Web. 23 Sept. 2014.
- [2] Lohman, Kevin. "Project 5 - DTC Bi-directional Lifting Bar." *Www.campus.fsu.edu*. Florida State University, 31 Aug. 2014. Web. 26 Sept. 2014.
- [3] "Lifting Beams Design." *Lifting Beams Design*. N.p., n.d. Web. 26 Sept. 2014
- [4] "Metal-Pages - Tungsten Prices." *Metal-Pages - Tungsten Prices*. N.p., n.d. Web. 23 Oct. 2014.
- [5] "OSHA Law & Regulations." *OSHA Law & Regulations*. N.p., n.d. Web. 21 Oct. 2014.

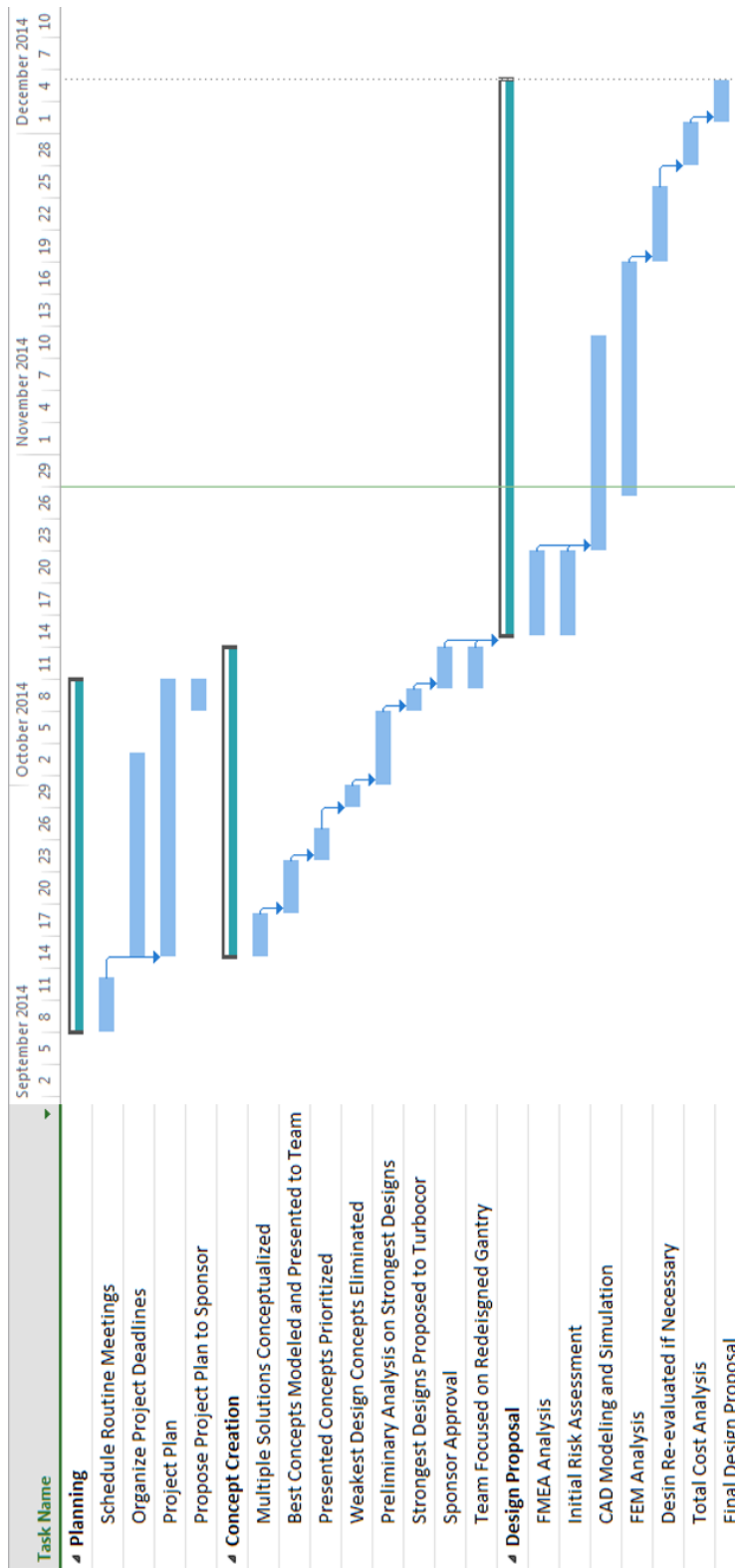

Figure 11 - Gantt Chart



# 8 Appendix B - Drawings

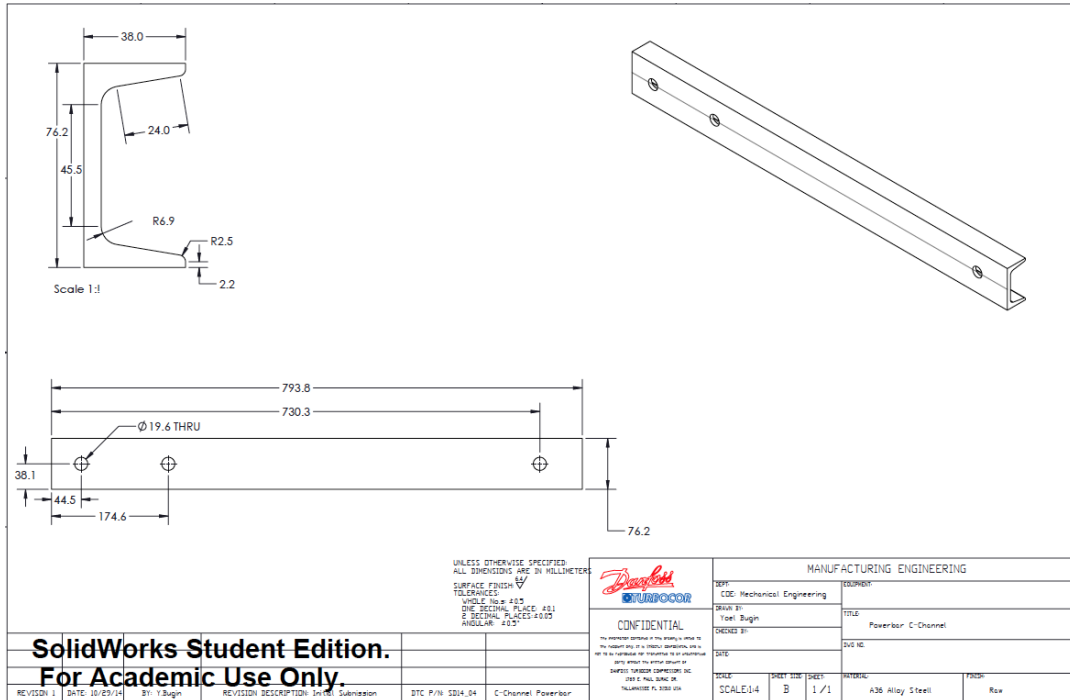

Figure 12 - Lifting Bar Drawing

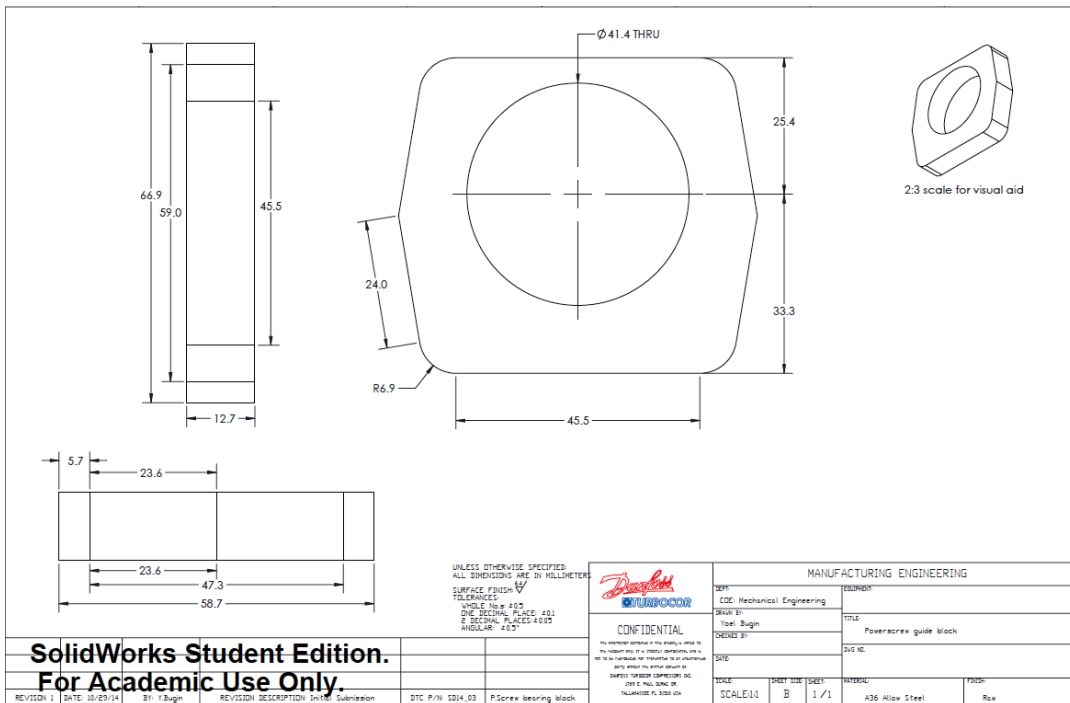

Figure 13 – Power Screw Guide Block Drawing

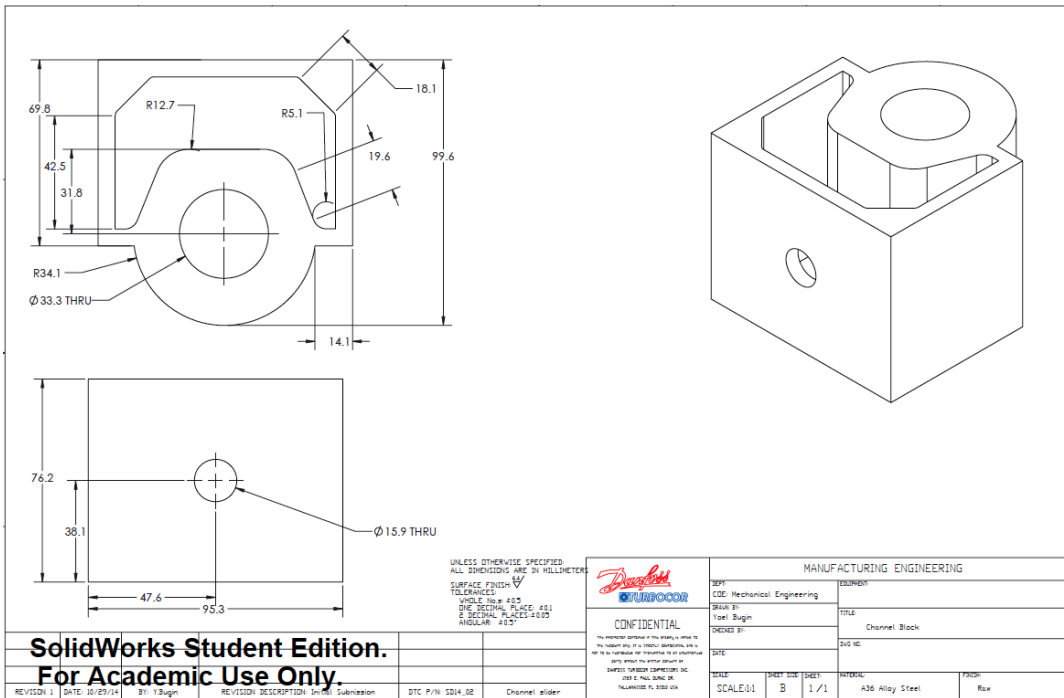

Figure 14 - Channel Block Drawing

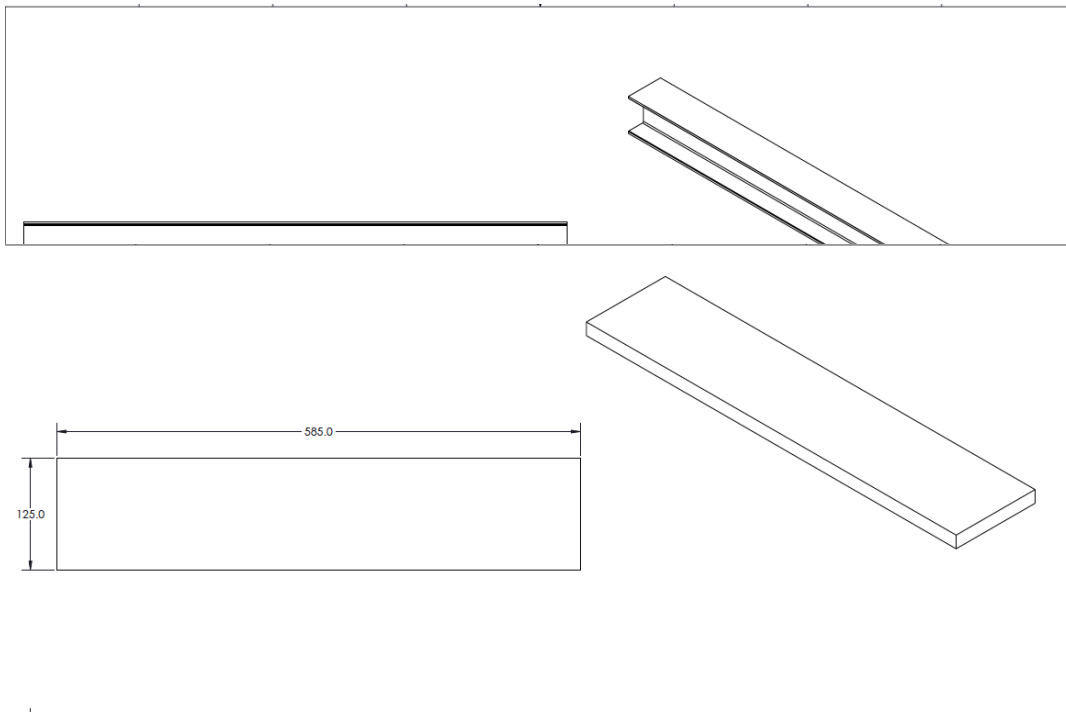

Figure 15 - I-beam for Gantry System Drawing

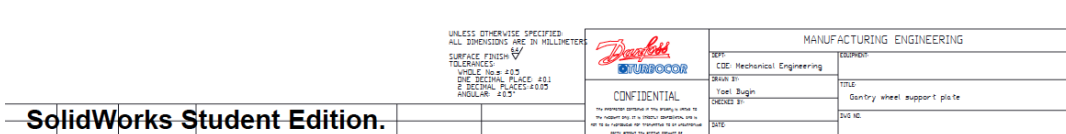

Figure 16 - Gantry Support Plate Drawing

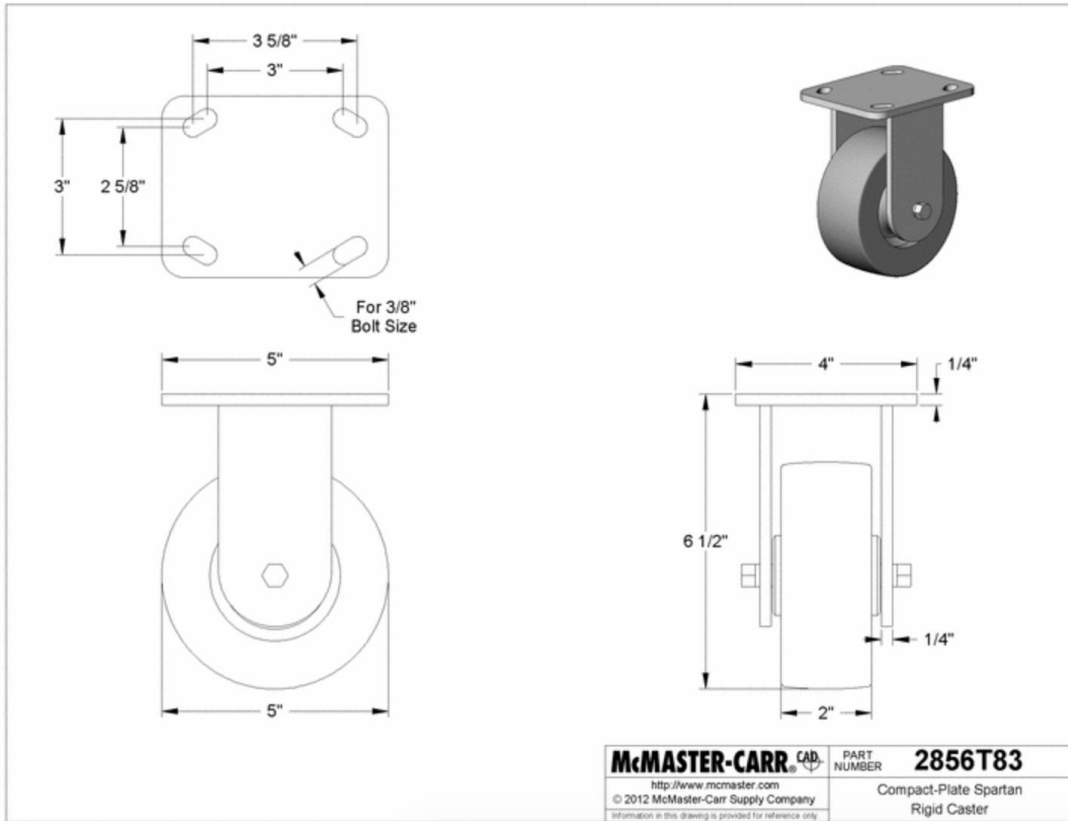

Figure 17 - 5" Caster Drawing