

Shuttle Valve Design

Team #17

Date

March 20th, 2014

Group Members

Ryan Laney – Team Leader

Billy Ernst – Team Webmaster

Samantha Zeidel – Team Treasurer

Instructor

Dr. Kamal Amin

Sponsor

Verdicorp Inc.
Robert Parsons



Faculty Advisor

Dr. Steven Van Sciver



Project Overview

- Verdicorp Environmental Technologies has developed a revolutionary Organic Rankine Cycle (ORC)
- ORC uses waste heat from a low grade source and converts it to useful power
- The ORC systems have somewhat low efficiency (~10-14%); Special concern within the company to maximize this efficiency in any way possible
- ORC is cable of producing ~125 kW
- Parasitic losses consume ~20 kW
 - (Pump ~10 kW)
- Senior Design Team 17 has been tasked with increasing the efficiency of the system
 - (Removal and replacement of the pump)

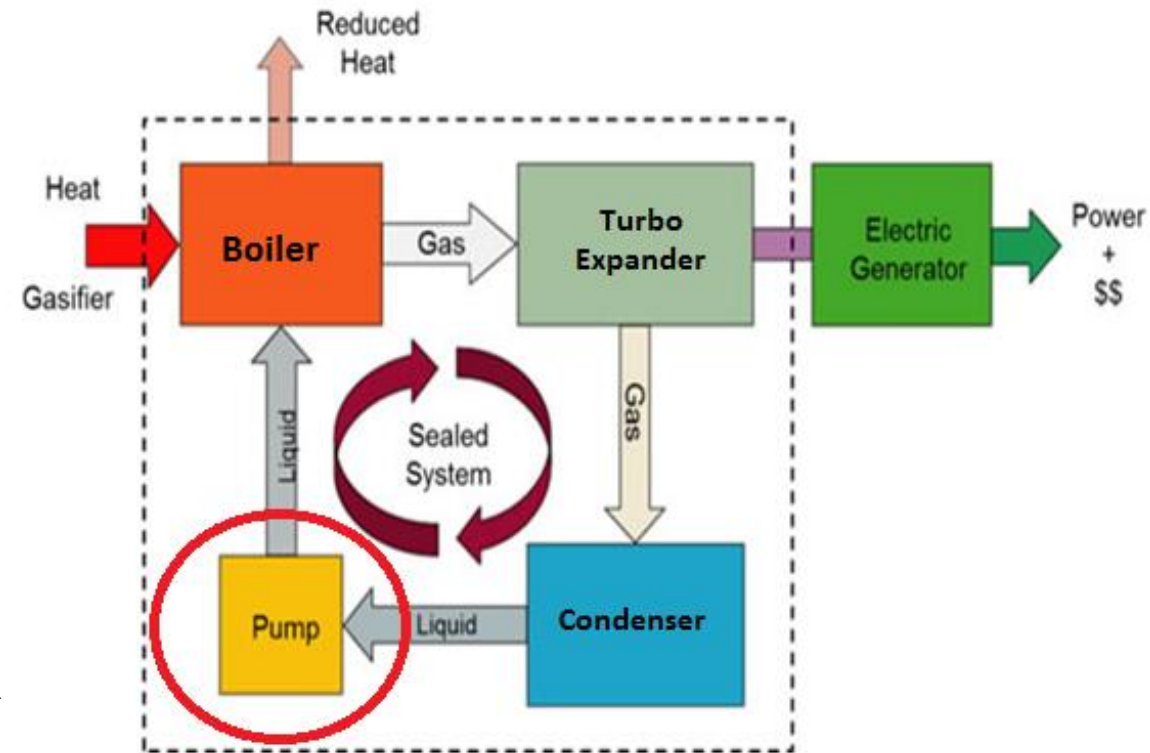

Presented by: Ryan Laney

Fall Accomplishments

- ▶ Understand the project and its applications
- ▶ Select the final design for the prototype
- ▶ Select the components for the prototype
- ▶ Procurement of these components
- ▶ Modify the final design with input from the sponsor
- ▶ Plan the construction and testing of the prototype for this semester



Current Objectives

- Complete the construction of the prototype
 - Piping and instrumentation
 - Electrical components
 - Wiring and logic
- Test and troubleshoot the prototype upon completion of its individual segments
- Final prototype completion and presentation to MEAC Open House (April 17th, 2014)



Final Design Concept

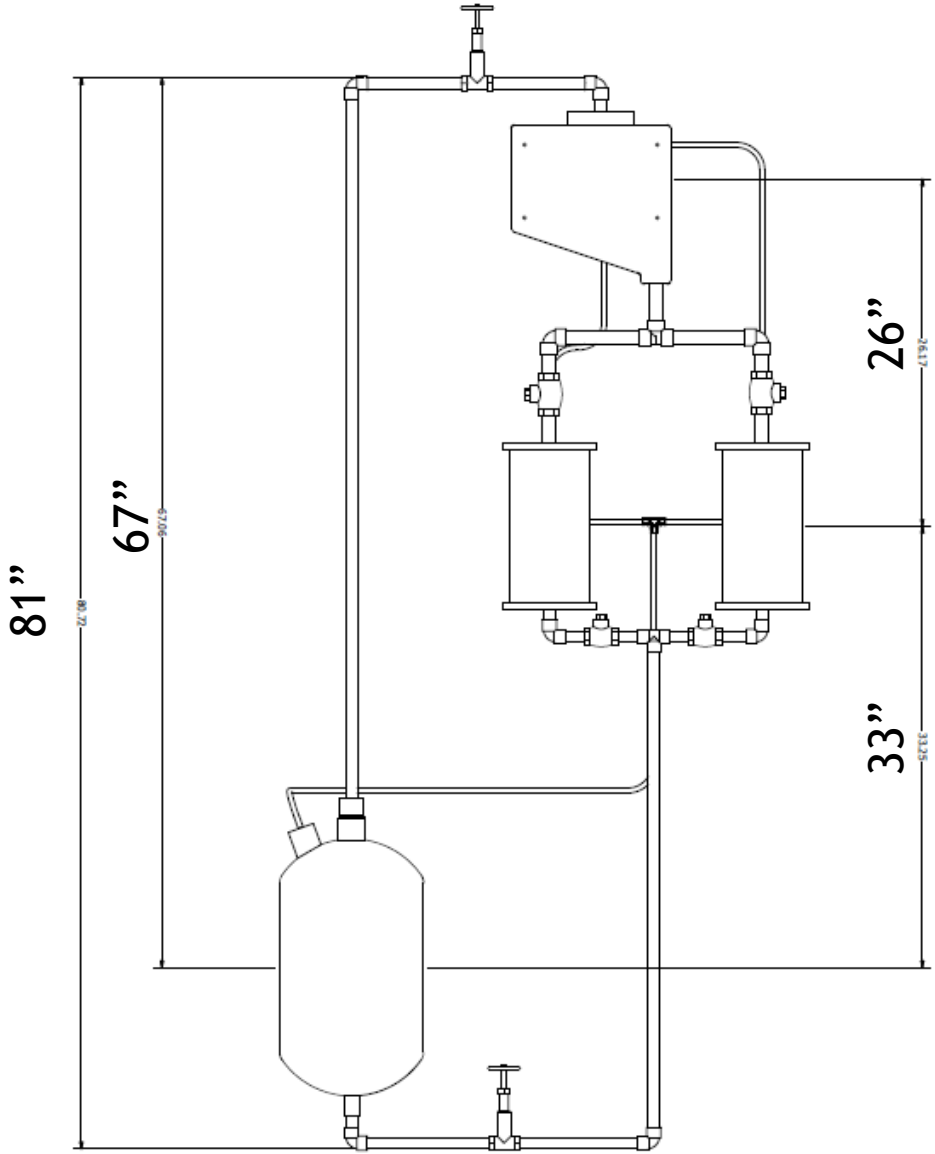
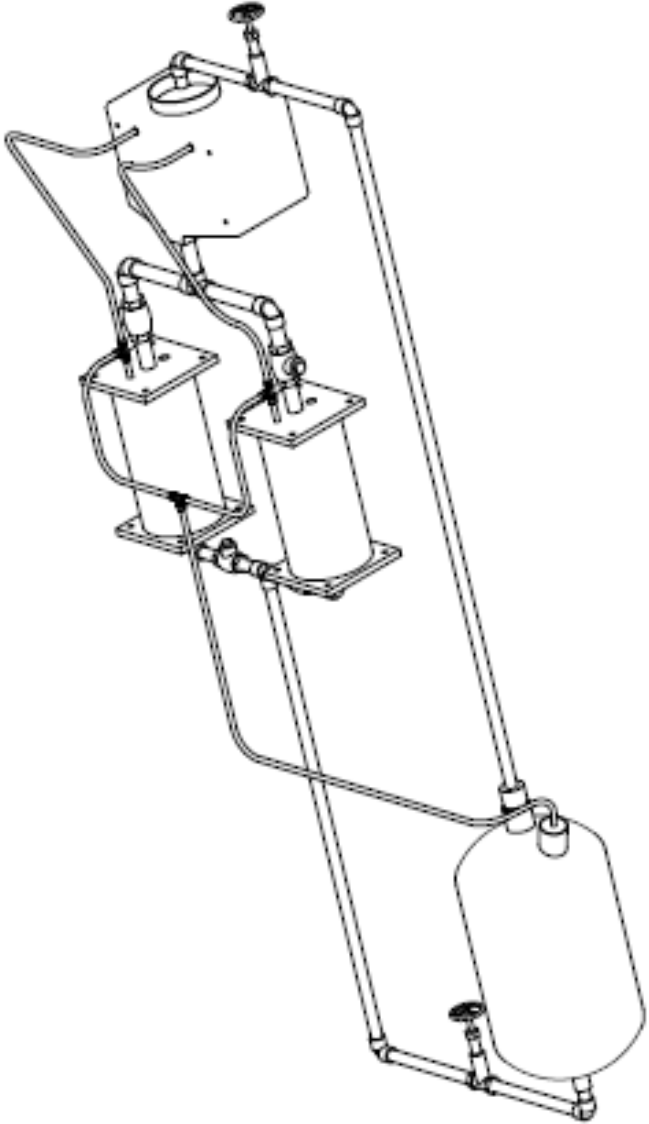

Presented by: Billy Ernst

Final Design Concept

► Holding Tanks 1 and 2 (Detail)

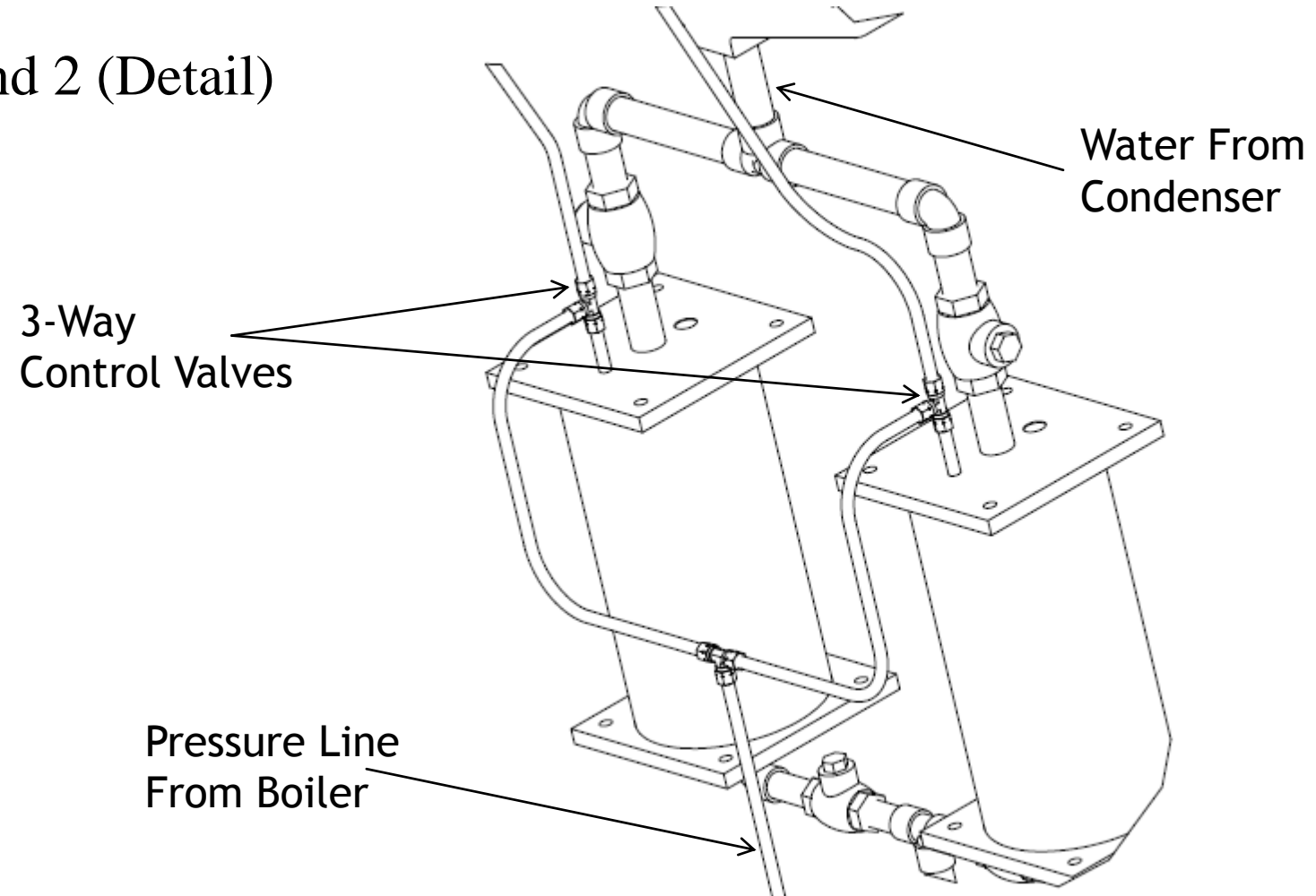

Presented by: Billy Ernst

Final Design Concept

- Execution of Holding Tank 1

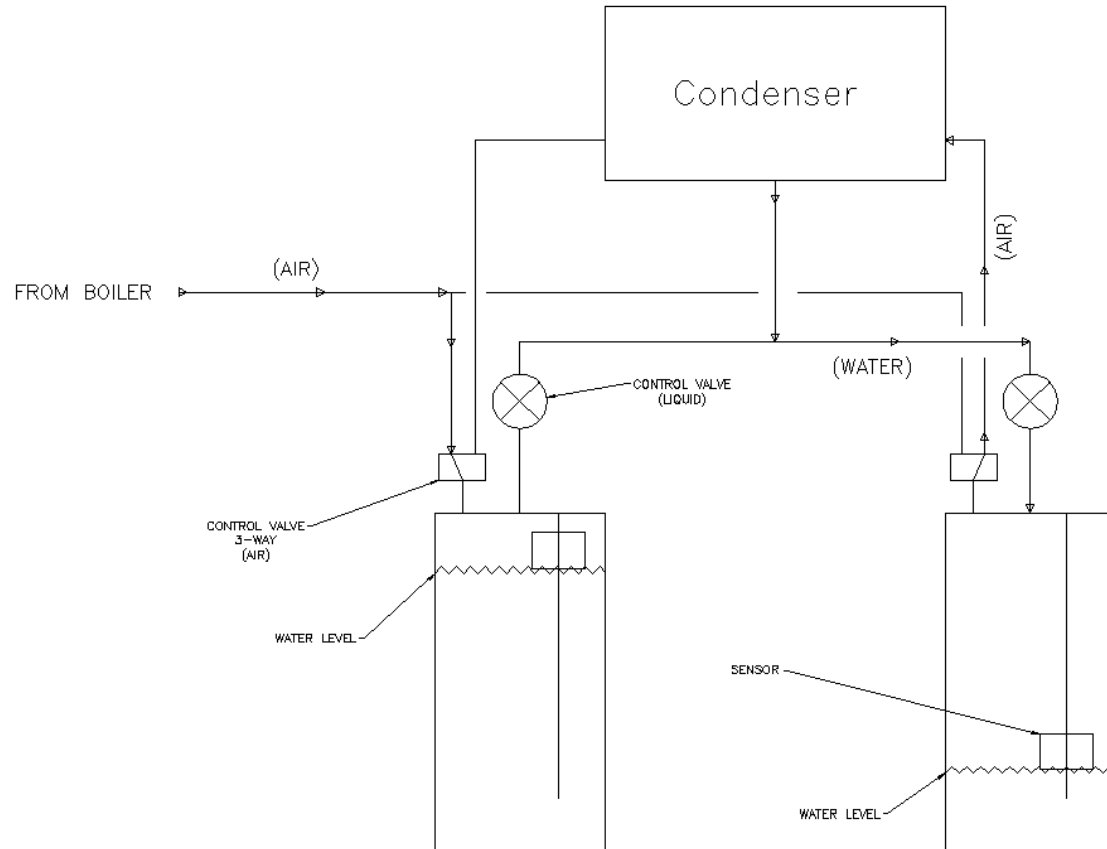

- Execution of Holding Tank 2

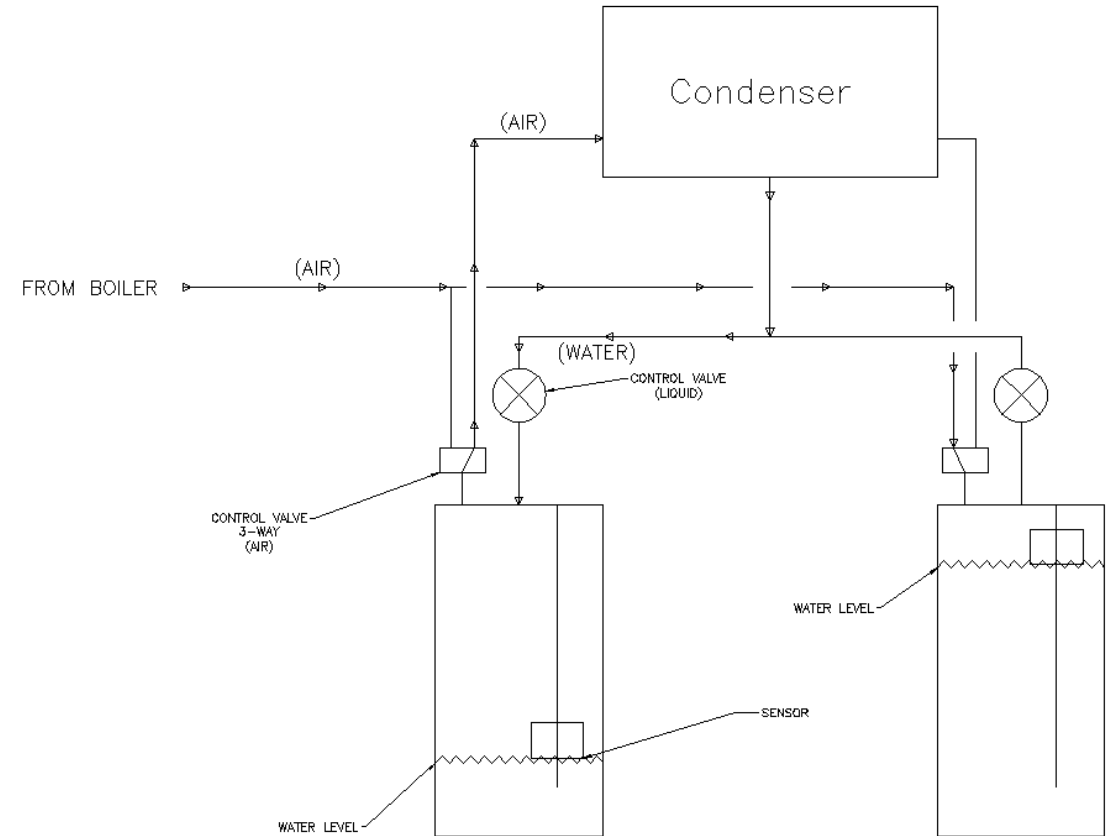

Presented by: Billy Ernst

PIPE-FLO Software Calculations



► Boiler to Condenser

- With an internal pressure in the boiler of 50 psi and using ½” PVC, the flow rate will be 39.04 GPM
- A throttling valve will be used to model the turbo expander and provide the pressure drop and decrease the flow rate to the desired 3 GPM

► Condenser to Holding Tanks

- Using ½” PVC, GPM (max) = 4.6 GPM

Greater than 3 GPM which is acceptable; Tanks will fill faster than they empty

► Holding Tanks to Boiler

- Using ½” PVC, GPM (max) = 4.46 GPM

Therefore ½” PVC must be used along with a throttling valve to restrict the flow down to 3 GPM

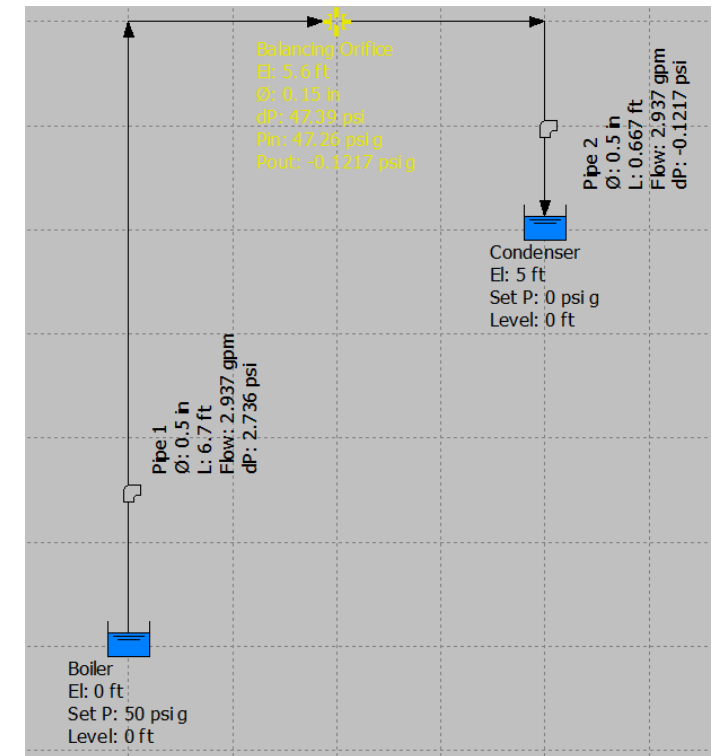

Presented by: Billy Ernst

Major Design Components

► Condenser

- Non-pressurized vessel in our system
- Two holes must be drilled into the top of the tank to allow for insertion of 3/16 in. copper tubing

► Holding Tanks

- Pressurized vessel in our system (50 psi)
- 1 ft. segments of 6 in. acrylic tubing were cut (**CHANGING**)
- 3/4 in. aluminum stock end caps were machined and press fitted to the tubing by 3/8 in. tie rods

► Boiler

- Pressurized vessel in our system (50 psi)
- Water level tube attached on outside of tank
- Two caps were machined for the two holes on top of the boiler
- Bottom of tank was modified to insert 1/2 in. PVC from holding tanks

Presented by: Samantha Zeidel



Electrical Components

► Air and Liquid Control Valves

- Air: 24VDC Pneumatic Single Solenoid, 3-way, 1/8 in. NPT
- Liquid: 24VDC Pilot Operated Solenoid Valves, 2-way, 3/4 in. NPT

► Power Supply

- Siemens 6EP1332-1SH31
- AC 230/120V to DC 24V converter

► Sensor

- Will be entirely constructed by the design team; 1/2 in. PVC pipe
- Outside: Magnet with Styrofoam attached to it (floats with water level)
- Inside: Salvaged magnet sensors (24VDC) adjusted until at proper heights

► Relay

- Purchased from McMaster-Carr
- Voltage: 24 VDC (Voltage for all electrical components)
- No coding required for electrical components



3/4" NPT - 24V DC

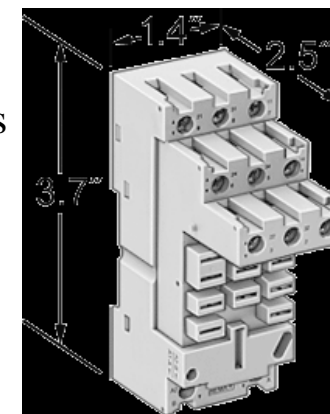

Presented by: Samantha Zeidel

Remaining Components

► Piping

- **Water Pipes:** ½ in. PVC Schedule 40
- **Pressure Pipes:** 3/16 in. Copper Tubing
- **All piping components will be threaded to allow for easy modification**

► Valves

- ½ in. PVC SCH 40 In-Line Check Valves
- ½ in. Plastic Globe Valves (Throttling)
- ½ in. Brass Gate Valve
- Require testing to decide which is optimal for design
- Pressure Relief Valve

► Pipe Fittings

- ½ in. PVC SCH 40 90° Elbow
- ½ in. PVC SCH 40 Tee
- ½ in. and ¾ in. Male Fittings

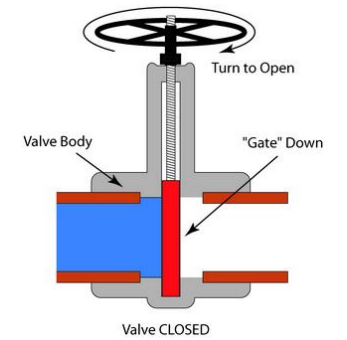
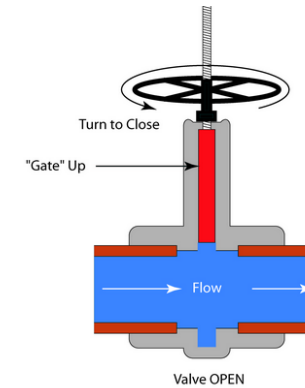

Presented by: Samantha Zeidel

Design Changes

► Holding Tanks (Walls)

- 6 in. acrylic tubing used for the walls of the holding tanks cracked
- Replaced by 6 in. polycarbonate tubing

► Holding Tanks (Execution)

- Sponsor requested that the holding tanks should fill completely before draining
- Simplifies the logic behind the electrical components in the system



Potential Challenges and Risks

► Challenges

- Time constraints
- Budget constraints
- Getting electrical components to work properly
- Filling up the prototype



► Safety Risks

- Machine shop safety
- Refrigerant 245fa replaced with water and compressed air
- Pressure relief valves to prevent over pressuring system



Presented by: Samantha Zeidel

Project Procurement

Component	Product Description	Vendor	Total Cost	Status
Boiler	6.25 Gallon Oil Extractor	Harbor Freight Tools	\$145.11	Received
Condenser	Ace / DenHartog 3 Gallon Rectangular Specialty Rinse Tank	The Tank Depot (Online)	\$54.15	Received
Holding Tanks (Walls)	6" Acrylic Tubing (Walls) Purchased a 6 ft. segment of tube	U.S. Plastics (Online)	\$88.20	CHANGED
Control Valve (Air)	Parker Air Control Valve Single Solenoid, 3-way, 2-pos, 1/8" NPT	Global Industrial (Online)	\$116.86	Received
Control Valve (Liquid)	Pilot Operated Solenoid Valves 2-way, 2-pos, 3/4" FPT	Zoro Tools (Online)	\$99	Received
PVC Piping, Components, and Fittings	PVC Piping: 1/2" and 3/4" Piping Pipe Components: 1/2" Throttle Valves PVC Fittings: Tees, 90° Elbows	The Home Depot	\$32.23	Received
PVC Fittings, Pressure Relief	Pipe Components: Plug Valves, PVC Fittings: Male Fittings for PVC	ACE Hardware	\$15.00	Received
Air Compressor, Sensors, Outer Frame, Pressure Piping	3.5 Gallon Pancake Air Compressor Sensors, and Outer Frame from old machines in Verdicorp machine shop	Verdicorp	\$0	Received

Presented by: Ryan Laney

Project Procurement

Component	Product Description	Vendor	Total Cost	Status
Flow Meter	Orange Research In-Line 2320 Series Flow Meter, 0-5 GPM	Harbor Freight Tools	\$106.00	Received
Holding Tanks (End Caps)	3/4" aluminum stock, O-ring, and threaded rods	Purchased through Verdicorp	\$114.52	Received
Holding Tanks (Walls)	Reordered 6" polycarbonate tubing for end caps	Purchased through Verdicorp	\$61.52	Received
PVC and Copper Components, Pressure Gauges	Additional PVC and Copper components and fittings. 0-100 PSI Pressure Gauges	ACE Hardware, Lowes	\$130.56	Received
Relays	24 VDC Relay That's Stays Switched, Sockets	Purchased through Verdicorp	\$43.17	Received

Component	Product Description	Vendor	Estimated Cost	Status
PVC and Copper Components	Additional PVC and Copper components, fittings, and piping.	Home Depot and Grainger	\$50	Pending

Presented by: Ryan Laney

Financial Analysis



- **Overall Budget: \$2000**

- **Expenditure (Purchased Components): \$1006.32**

- Air and Liquid Control Valves: \$215.86
- Heat Exchanger: \$145.11
- Condenser: \$54.15
- Holding Tanks (Walls): \$61.52 (**\$88.20**)
- Holding Tanks (End Caps): \$114.52
- Relays: \$43.17
- PVC Piping, PVC Fittings, Standard Valves: \$47.23
- Air Compressor, Sensors, Outer Frame, Pressure Line Piping: \$0
- Flow Meter: \$106.00
- Pressure Gauges, PVC and Copper Components: \$130.56

- **Estimated Expenditure (Remaining Components): \$50**

- Additional PVC and Copper components: \$50

- **Total Expenses: \$1006.32**

- **Remaining Budget: \$993.68**

Presented by: Ryan Laney

Project Summary

► Final Design

- Modifications have been made to the final design selected in the Fall semester, but conceptually still the same design.
- Pending the testing of individual segments of the prototype, modifications will be made based on team and sponsor input.

► Project Components

- All of the components have been selected and purchased for the prototype.
- Machining of the components requiring modification has already begun.

Presented by: Ryan Laney



Future Plans



- ▶ Finish constructing and machining components that require modification
- ▶ Construct the sensors and get all electrical components working
- ▶ Continue building and testing individual portions of the system
- ▶ Analyze the operation of the prototype and make necessary improvements
- ▶ Have the entire prototype ready for full-scale testing by the end of March 2014.



Any Questions, Comments, or Advice?

Presented by: Ryan Laney