

**Final Fall Design Deliverable**

**EML 4551C – Senior Design – Fall 2012 - Deliverables**

**Team 5**

**Production Test Fixture for Sensor Ring Testing**

**Team Members**

**Christopher Brink**

**Omar Izaguirre**

**Quy Nguyen**

**Mark Palmieri**

**Project Sponsor**



**Kevin Lohman**

*Mechanical Engineer*

**Boris Bayevsky**

*Manager of Hardware Design*

**Dr. Farrukh Alvi**

*Project Advisor*

**Dr. Kamal Amin**

**Dr. Chiang Shih**

*Project Instructors*

*Department of Mechanical Engineering, Florida State University, Tallahassee, FL*

# Table of Contents

<b>Executive Summary</b> .....	<b>3</b>
<b>Current System</b> .....	<b>4</b>
<b>Problem Statement</b> .....	<b>6</b>
<b>Constraints</b> .....	<b>6</b>
<b>Background</b> .....	<b>7</b>
<b>The Final Design</b> .....	<b>8</b>
Switching From X to Y Axis Measurements .....	9
Spring System .....	10
Air Cylinder System .....	15
Z Axis Motion and Measurement System.....	17
X-Y Axis Combination Slide System .....	18
Mechanical Stop System.....	19
LVDT: Displacement Measurement System .....	20
<b>Current Cost Analysis</b> .....	<b>21</b>
<b>Future Work</b> .....	<b>22</b>
<b>Safety and Environmental Concerns</b> .....	<b>23</b>
<b>Conclusion</b> .....	<b>23</b>
<b>Gantt Chart</b> .....	<b>24</b>
<b>Appendix</b> .....	<b>27</b>
Appendix I – Initial and Preliminary Design .....	27
Appendix II – Part Drawing.....	31

# Executive Summary

Danfoss Turbocor is currently seeking a way to optimize sensor testing for their compressors. While their current system is able to test these sensors it is not reliable. The fixture has to be calibrated after a certain number of sensor rings have been tested in order to ensure that the measurements are accurate. Danfoss Turbocor has sponsored a senior design project to design and build a new sensor test fixture rig in order to improve quality and production time.

In order to complete this task certain specifications have to be met in the new system. Each direction of measurement has to be independent of each other as to not interfere with the other sensor readings. The displacement only needs to be approximately 400 micrometers with an accuracy of 2 micrometers. The movement needs to have three distinct stopping points to take measurements. It also needs to have minimal backlash. These constraints are all most important and must be taken into consideration of the design of the system. Concept designs are developed and then eliminated until a final design is chosen. This design has been modeled in CAD software with mechanics analysis. While this system may still need more improvements, it does give Danfoss Turbocor a starting point to solve all of their issues. Once the fixture has been assembled testing and calibration of the system will happen, which will help refine any changes that need to be made.

# Current System

Danfoss Turbocor produces compressors for industrial and commercial use in HVAC systems. These compressors are outfitted with two sensor rings that sense any movement from the shaft, this ensures that the shaft is centered and tells the operator if calibration is needed. On the production line a sensor testing rig is used to test the accuracy and precision of these sensors.

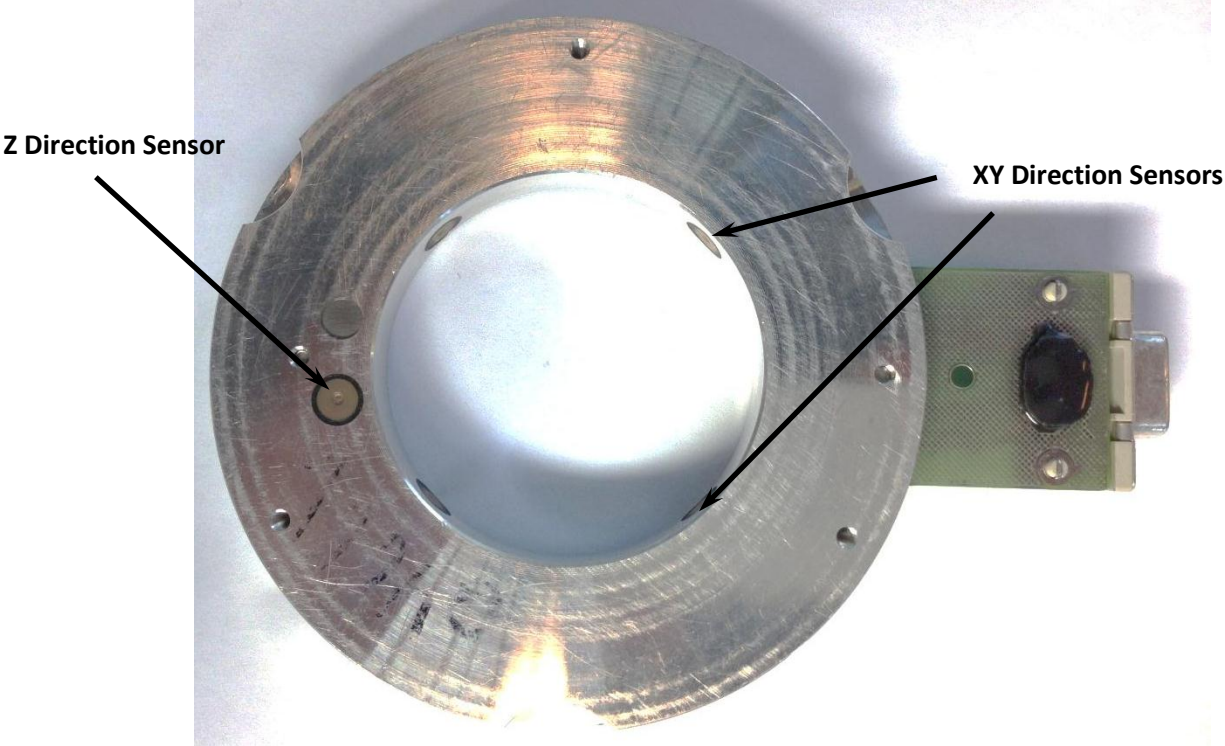

Figure 1: Sensor Ring and Location of Sensors

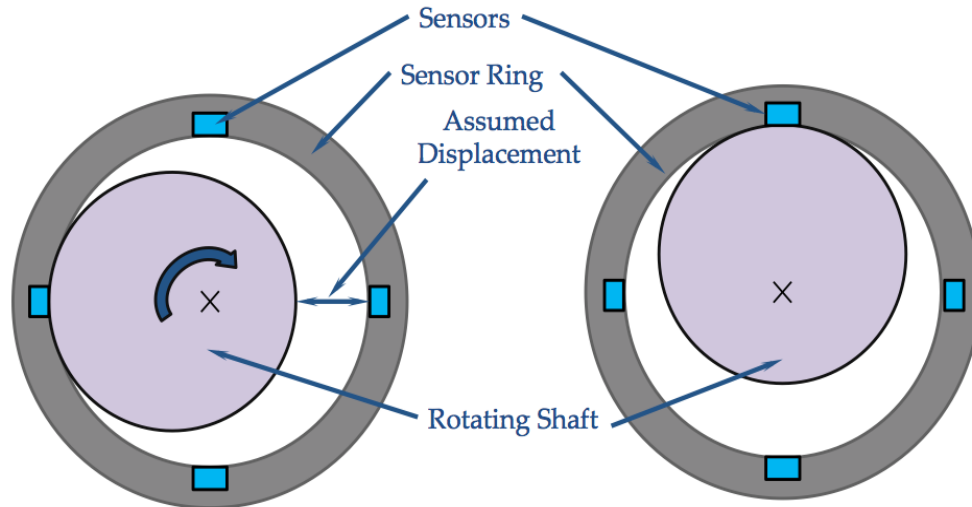

Figure 2: Schematic of Current System

The sensor ring is mounted onto a shaft and it is spring loaded so the sensor ring does not move. The shaft is off center from the sensor rings center so that the edge of the shaft is touching the inner edge of the ring, covering the sensor that reads the X-Direction. This contact that is produced has an assumed displacement of 0 micrometers. The distance from the other side of the shaft to the other side of the sensor ring is measured to be approximately 400 micrometers. From here the shaft is then rotated, using a stepper motor,  $90^\circ$  so that the shaft is now touching the Y-Direction sensor. In the Z-Direction a flange is protruding from the shaft, so as it rotates the flange will cross the Z-Direction sensor and give a reading.

This fixture has quite a few problems that cannot be overlooked. The assumed displacement is a major contributing factor in the constant need to recalibrate the fixture. The distance of 400 micrometers has to be measured repeatedly after a certain number of rings have been tested; this is because the shaft does not line up exactly to the same position on every ring. Furthermore, there is no independent displacement measuring system in place to track the actual motion. The stepper motor also poses a problem. As the motor rotates the shaft and comes to an abrupt stop, the shaft moves forward or backward a miniscule amount. This movement is not negligible simply due to the scale of magnitude of precision that is required. Finally, a better way of measuring displacement in the Z-Direction has to be developed. In the current design only one position measurement can be read, when the flange passes over the sensor.

# Problem Statement

The goal of this system is to create a sensor test rig that will ensure that the sensors being produced are up to the quality Danfoss Turbocor's needs. Danfoss Turbocor is currently using a sensor testing platform that requires an assembly worker to mount the sensor ring on to the tester. The tester is then initiated and outputs a reading so that software acquires the data and determines whether the sensors will pass or fail for use in a compressor. The existing mechanism that displaces the sensors ring has backlash, which leads to inaccurate sensor reading. Thusly it is unsuitable. The problem that arises is the platform continuously needs to be calibrated after a certain amount of sensors are tested. This slows productions time down and decreases the reliability of the test rig. In order to improve efficiency, a system which reliably tests the sensor is needed.

# Constraints

Danfoss Turbocor has a set of requirements that the new system must be able to do. The fixture must be able to test in the XYZ-Directions independently. Unlike the current system where when the X-Direction sensor is tested, the reading given off by the Y-Direction sensor changes, this systems has to be able to measure one sensor without affecting the others. There must also be at least three positions at which the sensors can stop and take readings from. Generally it would be from the two extremes of the sensors and when the shaft is centered in the ring. A resolution of 2 micrometers is required for our displacement measurement, so that the sensors can accurately be compared to it. In total, the shaft must be able to move 400 micrometers diametrically, or 200 micrometers radially. Finally, the system has to minimize the backlash so that the known displacements the shaft is moving can be compared to the sensors.

# Background

Our team was tasked with developing a production test fixture for testing of the sensor rings that are used inside their extremely efficient compressors. The most important feature being the test fixture must create uniaxial displacement for testing the sensor ring's sensors individually for each direction. Initially the most appealing design was to implement a three-direction linear stage, one that would be designed and fabricated by hand. This proved impractical and not favorable for our time constraints.

So our next concept included using a commercial linear stage (Appendix I) to maintain the precise movements, and building a fixture around that. However, this design had its flaws as well. High cost and excessive manual operation requirements hindered further development.

The final design proposal has a completely new approach to the testing procedure. Spring steel is planned to be utilized for a means of restricting the movement of the testing stage. This design scheme proves to meet all of the needs of Danfoss Turbocor, creating uniaxial movement that will both be observed and measured by the sensor rings. The advantages of this design far outweigh its downfalls, which still stack up against the previous design concepts.

## The Final Design

The final sensor test fixture design utilizes a spring concept paired with gas cylinder actuators to create three measurement positions. The sensor ring is mounted to a table. The table itself displaces along with the sensor ring. A mock shaft, mounted to the base plate, extends upward through the sensor mount table and the sensor itself.

Several sub-systems make up our final sensor ring test fixture design. The spring system is the primary element to our design. For this portion of our design, we are going to utilize a series of flat springs to center our test fixture after displacement occurs. To create displacement, a set of two air cylinders are mounted to either end of the fixture. A guide system helps us to maintain uniaxial motion. This guide system is located underneath the sensor mount table. The sensor ring itself is rotated 90° to switch from X measurements to Y measurements. For the Z direction, we chose to utilize a micrometer coupled with a spring bracket system. To ensure that we get no more than a total of 400 microns of displacement, we included a system of precision screw stops to restrict the movement of the sensor ring mount table. Finally, a set of LVDT's are used to acquire independent measurement of displacement. In the figure below is a SolidWorks rendering of our final product. In the paragraphs to come, each sub-system is described in more detail.

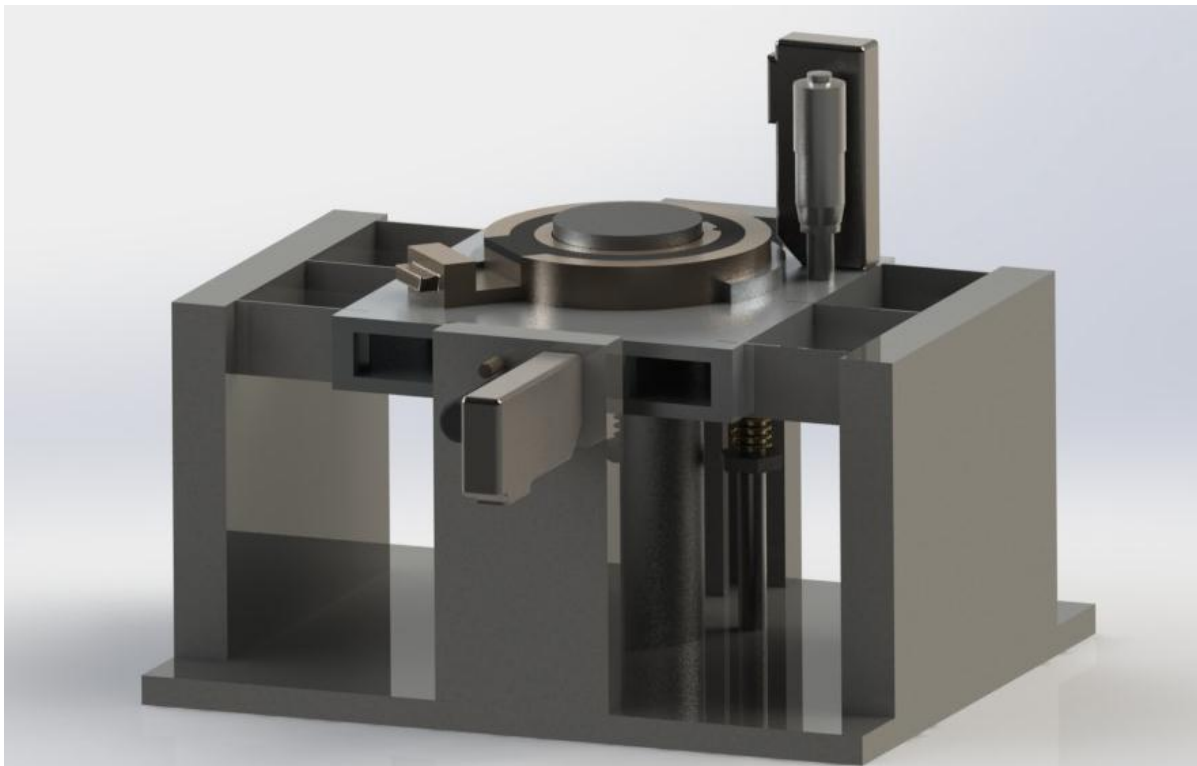

Figure 3: Fully assembled sensor ring test fixture



## Switching From X to Y Axis Measurements

In order for the test fixture to independently test each axis using the spring steel, the user is required to rotate the sensor ring 90° in the counter clockwise direction. This moves the two tested sensors around and exposes the other two radial sensors to the linear movement. This can be seen in Figure 4.

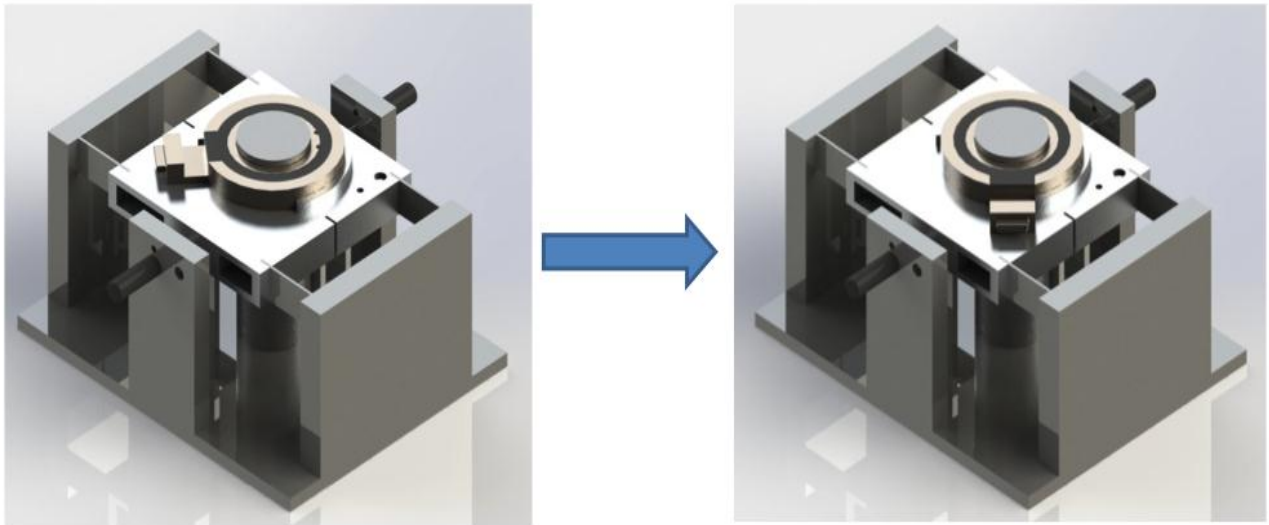

Figure 4: Left position-fixture takes X measurements, right position-fixture takes Y measurements

## Spring System

On our design, there is a series of springs that are designed to allow movement in only one direction. This system consists of flat springs that are positioned normal to our sensor mount table and perpendicular to the test fixture's base. This allows for movement table movement only in the directions normal to the face of the flat springs.

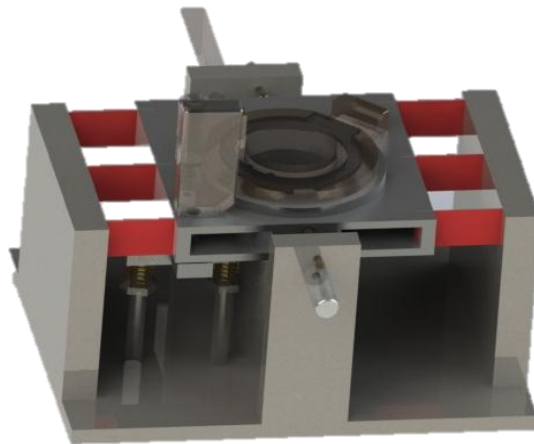

Figure 5: Spring system

In addition to creating uniaxial movement, the spring system's purpose is to return the sensor mount table to a center position after we have taken displacement measurements at the two extreme positions. In order to do this, we need a series of springs that will provide enough force to return the table to the center position, despite any frictional forces created by the slide system underneath the table. At the same time, the amount of force required to displace the table the required 200 micrometers in each direction needs to be small enough to not overload or air cylinder system.

Our approach to this problem was to analyze a variety of spring configurations and sizes prior to selecting our air cylinders. This allows us to attain the required amount of force to push the table so that we can select the proper air cylinders. In order to calculate the force required to push the table, we used finite element analysis with SolidWorks.

First, we needed to select a proper material in order to fabricate the springs. Our choice was to use AISI 301 spring tempered stainless steel as it has all the spring a stress qualities we require. It is also readily available through McMaster-Carr's online inventory. Then we ran stress and displacement simulations with various spring thicknesses and spring quantity.

Our initial configuration utilized four, two millimeter thick springs positioned in the manner shown in the figure below. The length of our springs was fixed due to space restrictions. The four spring configurations yielded a favorable amount of force required to displace the table 200 microns. However, this configuration required created too much stress on the springs, about 117 MPa. The yield strength for our spring steel is about 207 MPa. This is a factor of safety less than two, where we would prefer a factor of safety greater than three.

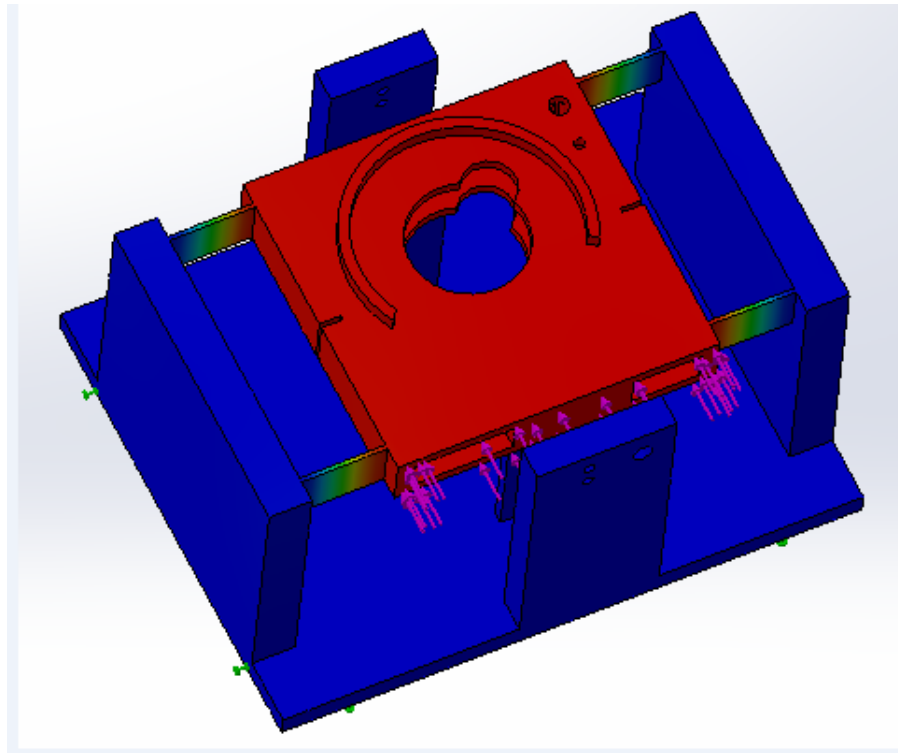

Figure 6: Four spring SolidWorks simulation (direction of motion indicated with pink arrows and red areas indicate regions of maximum displacement)

Next, we chose to use a six spring configuration. This is better than the four spring configuration for several reasons. First, the table is less likely to veer off the preferred axis of travel when force is applied than a four spring configuration. It also creates less stress per spring than the four spring set up. Our initial six spring configuration also utilized two millimeter thick springs.

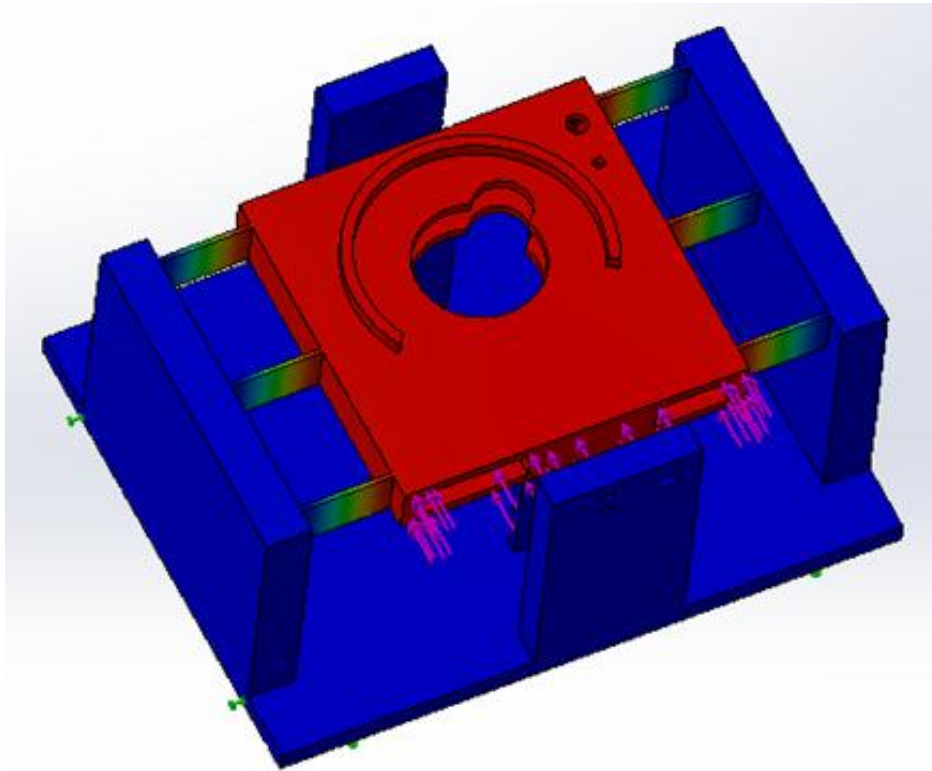
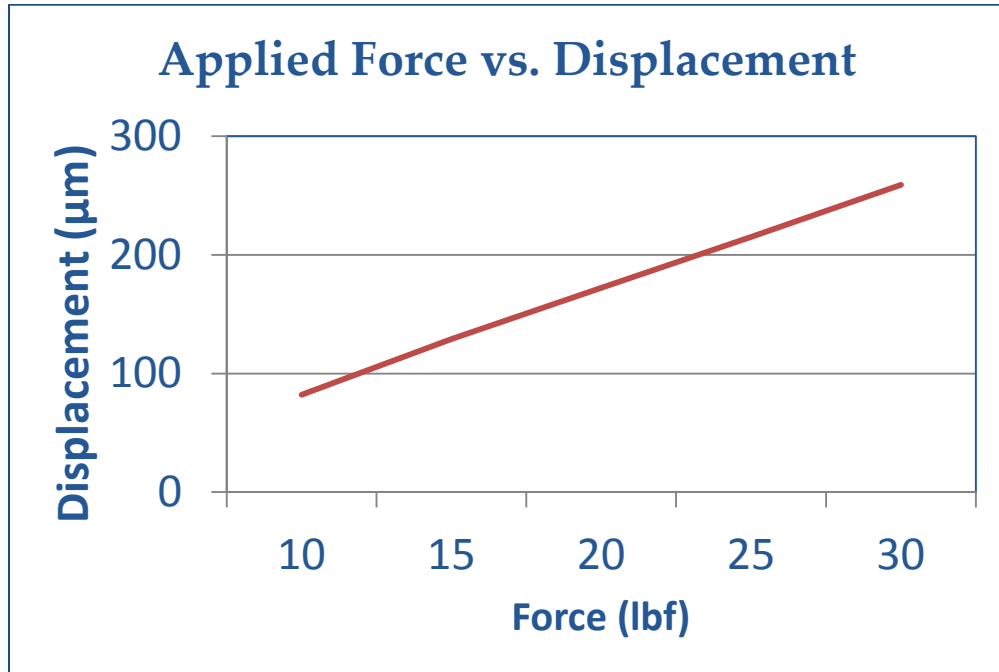

Figure 7: Six spring SolidWorks simulation (direction of motion indicated with pink arrows and red areas indicate regions of maximum displacement)

Using the six spring configuration with two millimeter thick springs gave us a favorable factor of safety but required too much force, approximately 175 lbf, to move the table 200 microns. It should be noted that our test fixture is relatively small, so large air cylinders are very difficult to mount onto our device. With this in mind, we chose to reduce the thickness of the springs to one millimeter each. When

this change was made, the required force for 200 micron movement was much more favorable. As we can see in the table below, with this configuration we require about 23 lbf to displace the table 200 microns in either direction.



Graph 1: Applied force vs. displacement (6 springs, 1mm thick each)

The stress created on our springs was also more favorable. At 200 microns displacement, there was a stress maximum of 58.2 MPa on our springs. The maximum allowable stress on our springs before yielding occurs again is 207 MPa. This gives us a factor of safety of 3.5. The figure below shows the stress vs. force curve of our system. Again, the amount of force required to move our sensor ring 200 microns is 23 lbf.

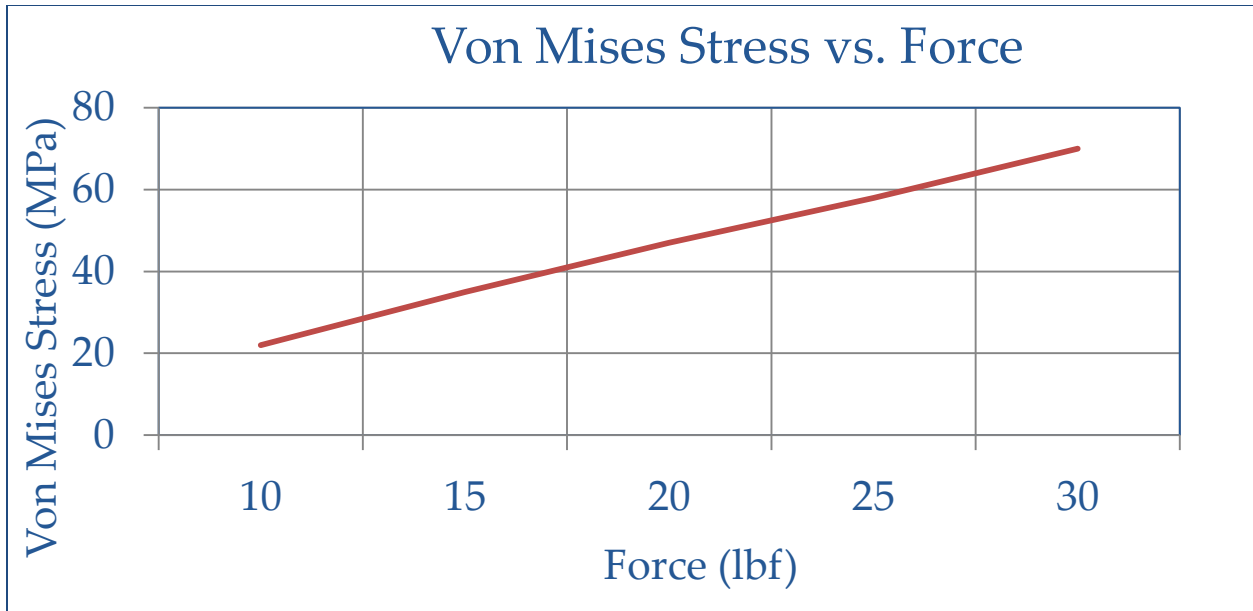

Graph 2: Stress vs. applied force (6 springs, 1mm thick each)

Our final decision was to use the six spring configuration with one millimeter thick springs. This provides us with a favorable amount of force required to move our sensor ring mount table. It also provides us with a system that is not over-stressed and prone to break at the springs.

## Air Cylinder System

The purpose of the air cylinder system is to move the sensor ring mount table to positions of positive 200 microns and negative 200 microns. One air cylinder will be mounted on opposite ends of the sensor mount table. They will provide movement along the movement axis of the table. Only one air cylinder will be engaged at a time. As one is engaged, the table will move to its positive extreme position. A measurement will then be taken by the sensor and the test fixture's LVDT's. At that point, the air cylinder will be disengaged. Next, the other air cylinder is engaged and the process is repeated for the negative extreme measurement.

Our choice of air cylinder was dependent upon the analysis of the spring system described earlier. We needed to choose the smallest air cylinder that could sufficiently meet our requirement of 23 lbf. Also, although stops are in place to prevent excess movement of the sensor mount table, we wanted to choose an air cylinder with a small stroke. For mounting purposes, we also require threads on the end of the cylinder's housing to screw into our mounting brackets.

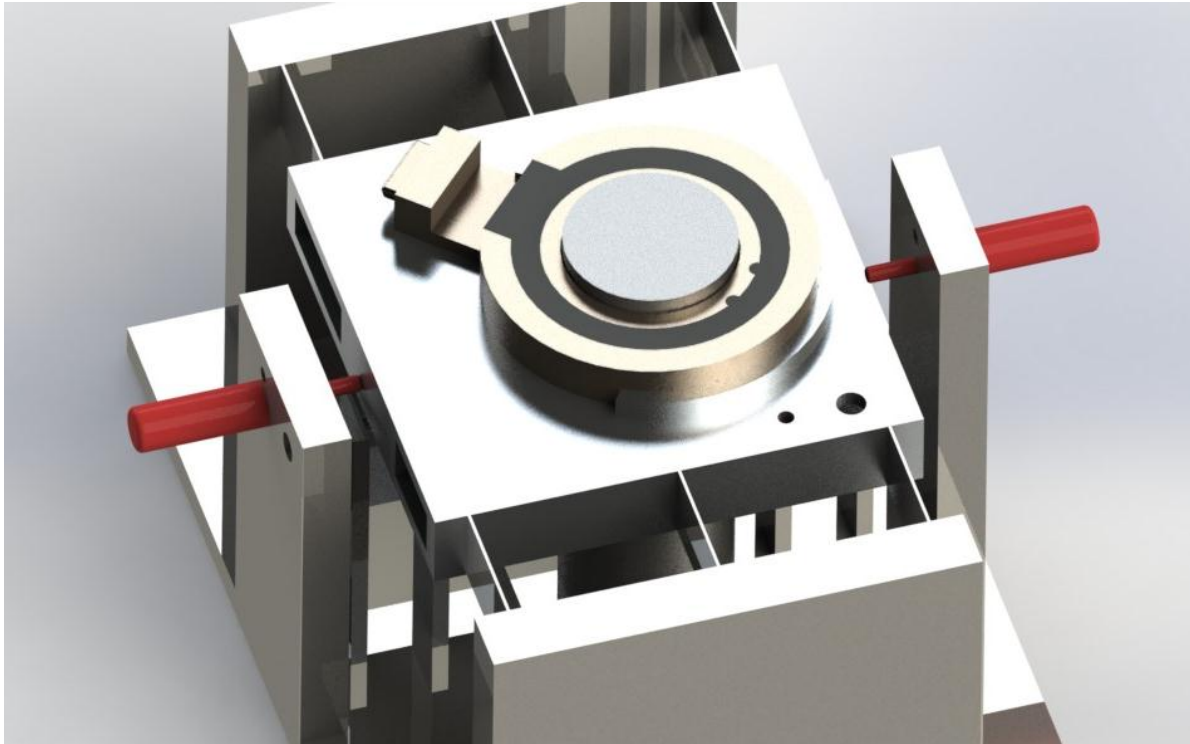

Figure 8: Air cylinder system (indicated in red)

The air cylinder chosen for our design is McMASTER-CARR part number 6498K132. This is an air cylinder with a 1/2 inch stroke and 5/8 inch bore size. At 100 psi, it produces 28 lbf. They are available with and without spring return and can be easily threaded to our mounting brackets.

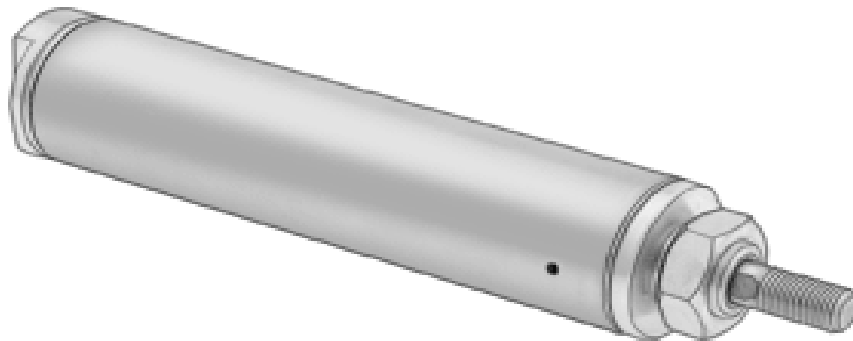

Figure 9: Air cylinder (McMASTER-CARR part # 6498K132)



## Z Axis Motion and Measurement System

Below the sensor ring carriage there is a spring-loaded bar, which is used in tandem with a micrometer head and LVDT to generate movement and sense displacement in the Z direction. The thickness of the test stage is greater than 400 microns, so a different way to measure the Z direction had to be developed. A rod protrudes from this platform and rises to the location of the sensor on the bottom of the ring. The rod moves as the micrometer head moves, but because the rod is close to the sensor we are able to get accurate measurements without any outside disturbances. The base platform is spring-loaded so that it can be raised and lowered by the micrometer head. The platform is polished so that as the testing system moves in the linear direction the rounded heads of both the LVDT and the micrometer glide across the platform. This is essential so that the heads do not break or get bent.

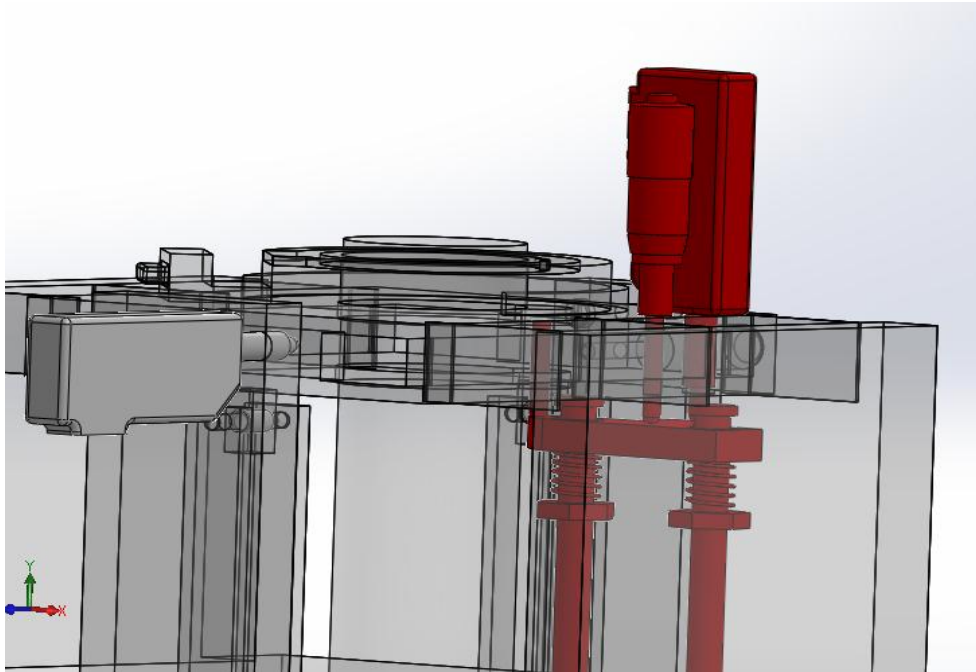

Figure 10: Z axis measurement system (indicated in red)

## X-Y Axis Combination Slide System

On the under-side of the testing stage, there are two linear translation guides. Two fixed blocks on the stage house linear bearings that control the movement of the test stage to only along the axis of the air piston. This is done to counteract the spring steels material characteristics that will tend to force the stage to translate outside of uniaxial movement, thus the need for linear guides. A clear image of the guides is shown in Figure 11.

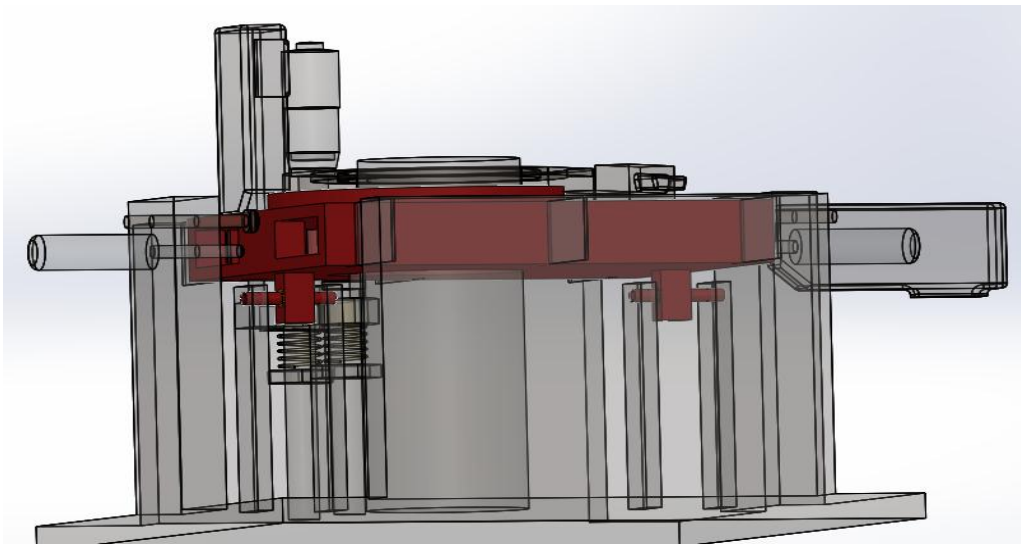

Figure 11: Sensor ring mount table slides used for X and Y direction (See ring rotation description, slide system indicated in red)

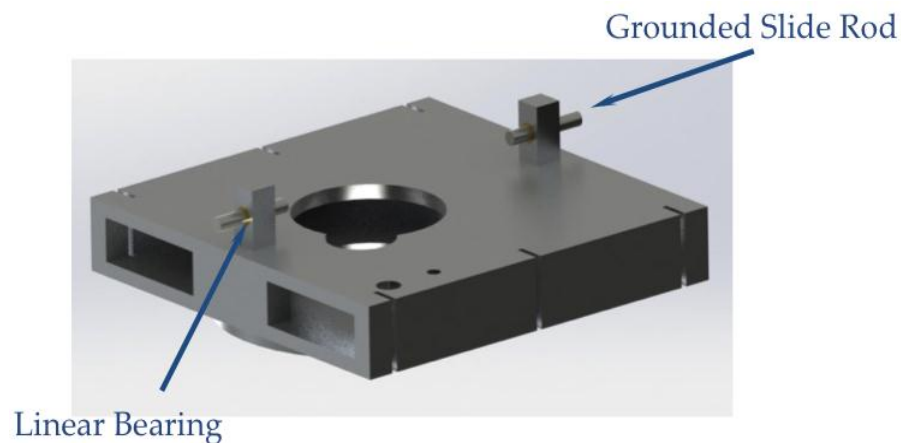

Figure 12: Sensor ring mount table underside with grounded slide rods and linear bearings

## Mechanical Stop System

In order to prevent the sensor ring mount from traveling past 200 microns, a stop is required. Many methods can be implemented such as micrometers or screws. Using screw-stops triumph other methods because we are able to easily and quickly adjust the distance if needed. The screws that will be used are known as precision thumbscrews. Shown in Figure 14 are the actual screws. It is made from 18-8 stainless steel, and it can withstand operating temperature up to 160°F. The heads sit on a shoulder making it easy to grab, and it is knurled, preventing it from slipping while being adjusted. The extremely fine thread gives exact control. Turning it will displace a small amount of distance, as required in our fixture. The screw will have a large round flat head, thus being able to handle the stress caused by the force of the table striking it. Maintenance is stress-free and also inexpensive. The screw can simply be taken out and replaced as often as needed. Shown in Figure 13 is where the screw will be positioned. Two stops will be used, one on each side of the table.



Figure 13: Mechanical screw stop system



Figure 14: precision thumb screw

## LVDT: Displacement Measurement System

The LVDT's shown in red in Figure 15 are used to account for any instances where backlash may occur. There is one mounted parallel to the motion caused by the air pistons, which observes the movements that tests the radial sensors. Similarly there is an LVDT mounted in-line with the axial sensor testing mechanism, to track the testing movements. The LVDT's were donated by Danfoss Turbocor, each of which has a resolution of 0.5 microns. This is more than enough to observe and quantify the physical displacement that takes place during the testing process.

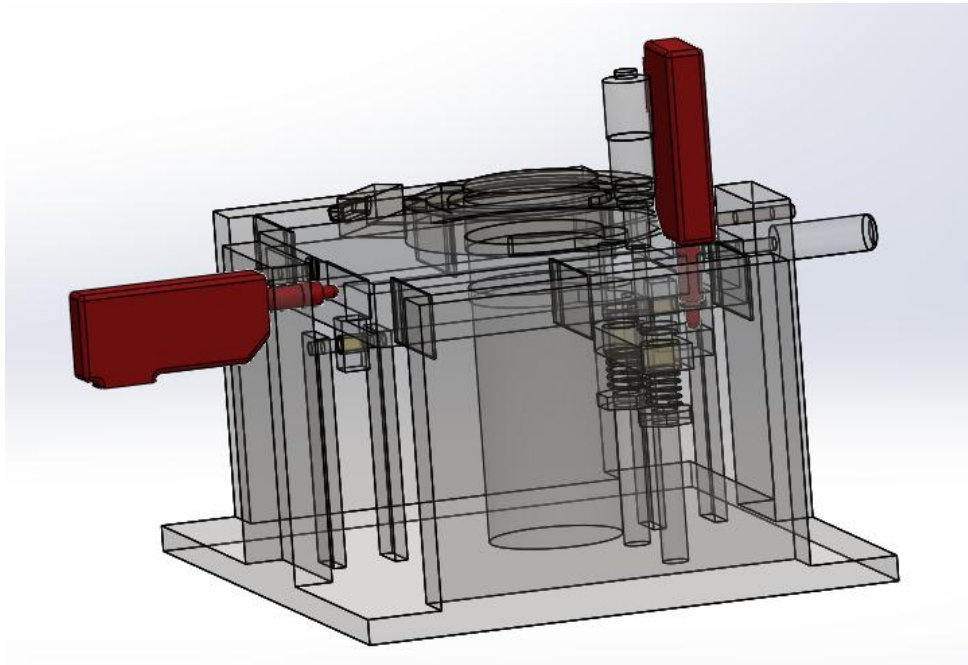

Figure 15: LVDT measurement system (indicated in red)

## Current Cost Analysis

The cost analysis table that follows lists all parts and raw materials required to build our sensor ring test fixture. However, it does not account for any machine hours or labor required for assembly of our device. More research needs to be done to accurately estimate the cost of labor. All machine hours and labor costs will be accounted for in further reports. It should be noted that although our parts and raw materials cost are well below our target budget of \$2000, the final cost could be significantly greater due to the large amount of machining that will most likely be required.

Quantity	Materials	Cost/Quantity	Cost
1	Multipurpose Aluminum 1/2" Thick X 8" Width X 1" Length	\$33.09	\$33.09
1	Multipurpose Aluminum 1" Thick X 6" Width X 1" Length	\$51.61	\$51.61
1	Spring Tempered 1074/1075 Spring Steel .094" Thick, 1/2" Wide, 5' Long	\$26.18	\$26.18
1	Multipurpose Stainless Steel (Type 304) 2" Square, 1' Length	\$130.39	\$130.39
1	Multipurpose Stainless Steel (Type 304/304L) 7/16" Diameter, 3' Length	\$14.04	\$14.04
1	Type 316 SS Compression Spring 2.656" Length, .625" OD, .054" Wire Diameter, packs of 6	\$10.75	\$10.75
1	Grade 8 Alloy Steel Hex Head Cap Screw Zinc Yellow-Plated, 7/16"-20 Thread, 4" Length	\$7.63	\$7.63
1	Type 316 Stainless Steel Hex Nut 7/16"-20 Thread Size, 11/16" Width, 3/8" Height	\$5.22	\$5.22
1	Multipurpose Stainless Steel (Type 304/304L) 3/16" Dia, 6' Length	\$9.36	\$9.36
4	Fixed-Alignment Linear Ball Bearing Closed, Stainless Steel, 3/16" Shaft Dia	\$9.18	\$36.72
1	Multipurpose Aluminum (Alloy 6061) 2-1/8" Diameter X 1' Length	\$24.62	\$24.62
1	Grade 8 Alloy Steel Hex Head Cap Screw Zinc Yellow Pltd, 1/4"-20 Thrd, 3/8" L, Packs of 100	\$12.30	\$12.30
2	18-8 SS Precision Adjustment Thumb Screw 3/16"-100 Thread, 3/4" Length	\$14.88	\$29.76
2	Stainless Steel Air Cylinder Nose-Mount, Spring Return, 5/8" Bore, 1/2" Stroke	\$12.75	\$25.50
2	Linear Variable Differential Transformer	\$600	Donated
		<b>TOTAL</b>	<b>\$417.17</b>
		<b>COST</b>	<b>+Labor</b>

Chart 3: Sensor test fixture cost analysis (excluding machine hours)

# **Future Work**

## **Assembly**

In the upcoming semester, there are several tasks that need attention in order to complete our design. First, we need to order all of our parts and raw materials. So far, all parts and materials can be obtained through McMaster-Carr.

Next, we must turn our part drawings and raw materials in for machining. Due to restrictions on the tolerances of our parts, Danfoss Turbocor has graciously offered to machine our parts for us. Special attention must be paid to the alignment of our parts in order to maintain precision. Once this is complete and all other parts have been received, we can assemble our sensor ring test fixture.

## **Calibration and Testing**

Calibration and testing will be no easy task. First, we must connect our LVDT's to Danfoss Turbocor's computers to be able to independently measure the displacement of the sensor ring. Next, we must calculate the actual ratio of air pressure to sensor ring displacement in our system as factors such as friction and miss-alignment will play a role. In addition to displacement measurement with the LVDT's used by our test fixture, we must also use a separate source of measurement. This will ensure that our system is measuring our ring's displacement correctly. Since the test fixture that is currently in use is deemed inaccurate, we cannot connect a known good sensor ring to our fixture for calibration.

## **Final Cost Analysis Revisions**

A revised cost analysis must be performed that includes all machine costs as well as other unforeseen costs that may have been acquired. This may include any wasted materials.

## **Safety and Environmental Concerns**

For safe operation of our sensor ring test fixture, several precautions should be taken. First, while pressure is being applied to the air cylinders, hands should be kept away from the test fixture. Although the fixture is only moving 400 microns, the sensor ring mount table is moving at high velocity and pinching could still occur. Second, Safety goggles should always be worn while performing sensor ring tests. When setting up the test fixture, the air pressure being applied to the air cylinders should be checked thoroughly. Too much air pressure on the air cylinders could result in broken parts becoming projectiles.

There are no batteries, corrosives, or poisonous materials being used in our design. Furthermore, our sensor test ring fixture is fabricated of mostly standard steels and aluminums. These are all recyclable materials. The sensor ring itself is disposed of by Danfoss Turbocor if it has failed the testing process.

## **Conclusion**

Our spring system simulations indicate that we will be able to displace our sensor ring without over-stressing the springs. These simulations also show that we can create the proper sensor ring displacement with the amount of air pressure available in a typical workshop. The linear guides will provide us with uniaxial movement with minimal frictional forces. At the same time, the mechanical screw stops will provide us with the desired range of motion. The design in place will provide a semi-automated system that will allow for quick testing in a manufacturing and assembly line environment. The only manually operated components are the Z measurement micrometer system and the switch from X and Y axis sensors. All other components are controlled by air cylinder trigger. Lastly, LVDT's allow us to get precise measurements of displacement without having to use any assumptions, like in Danfoss Turbocor's current test fixture.

# Gantt Chart

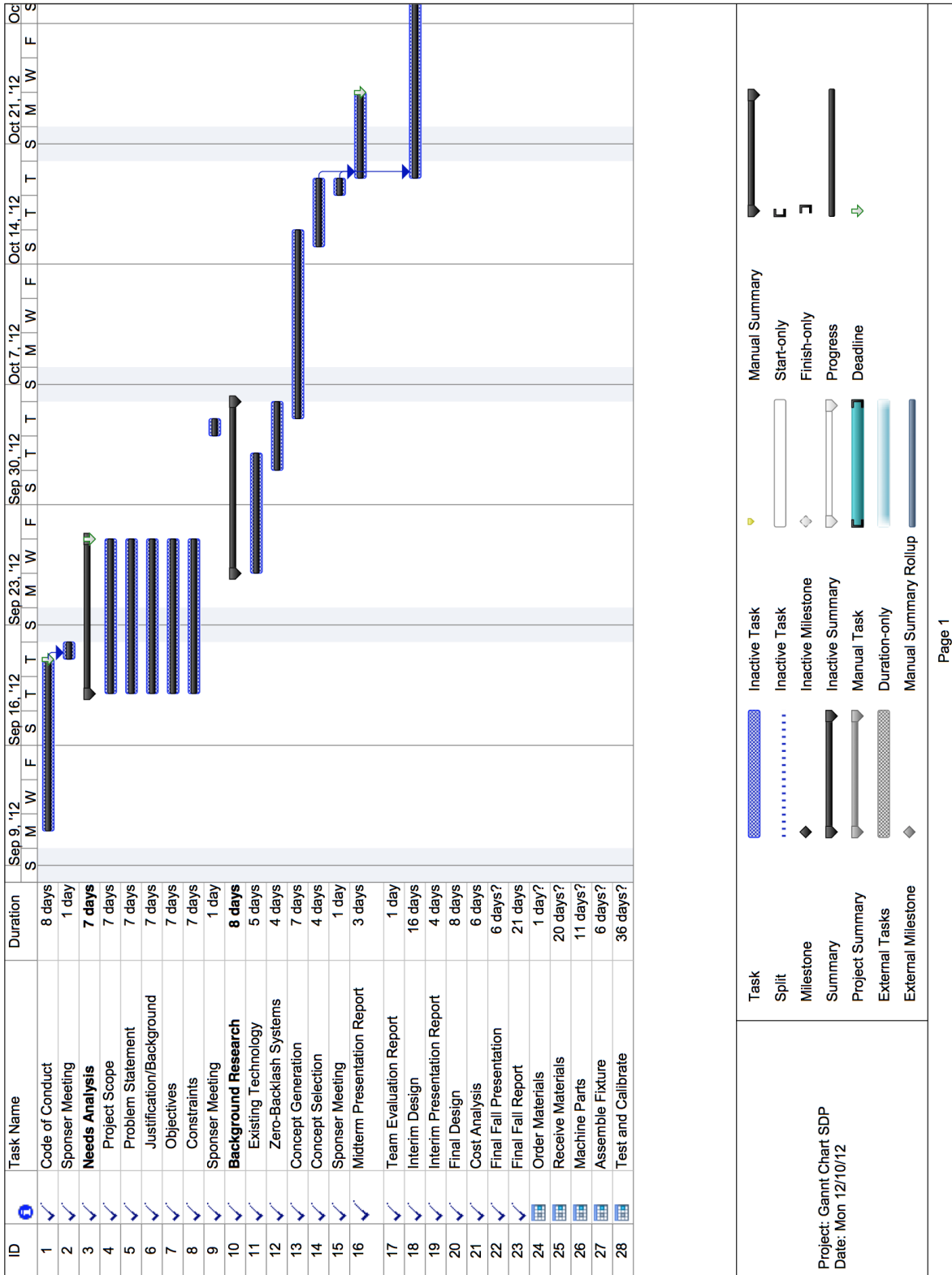



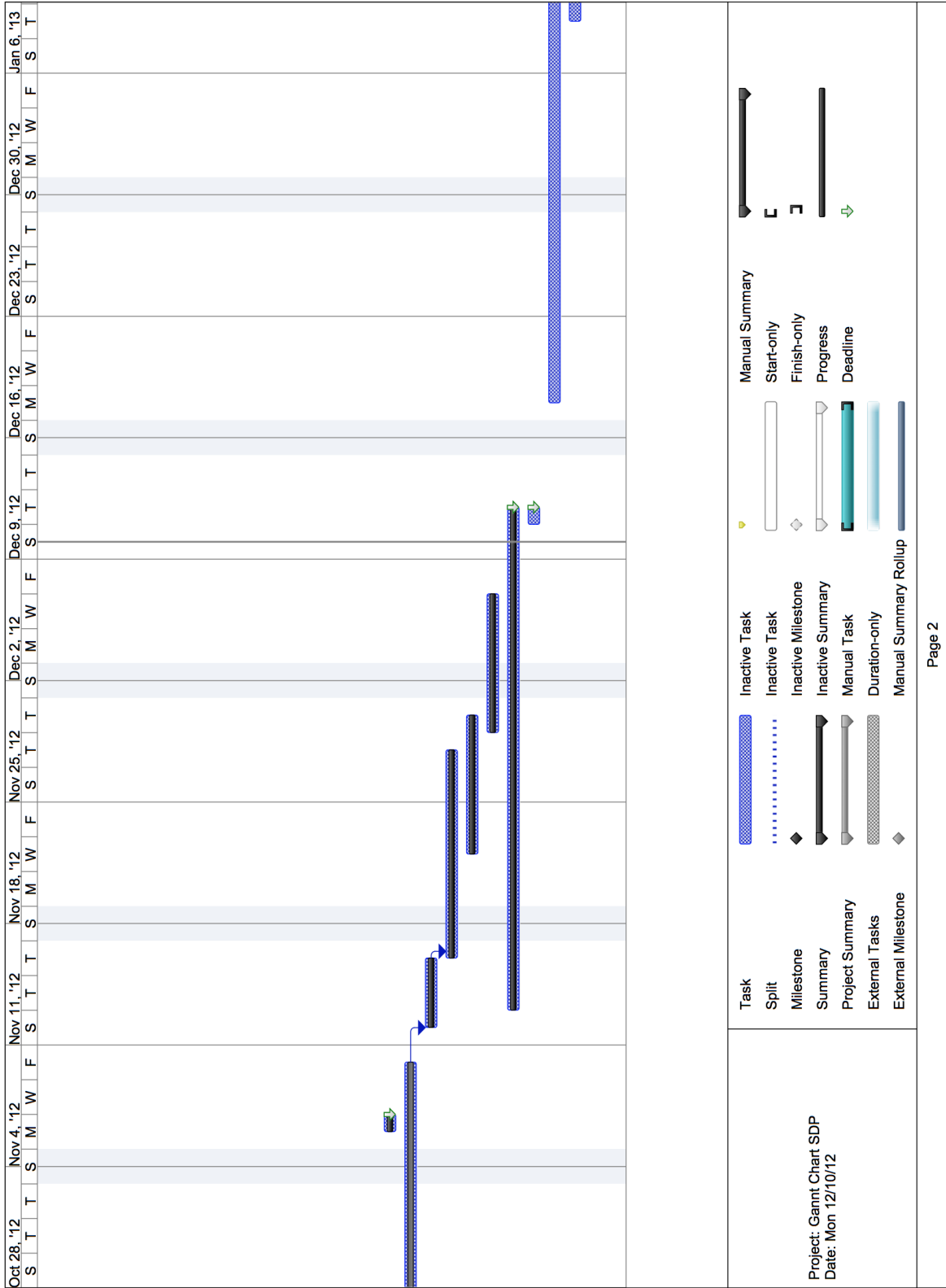

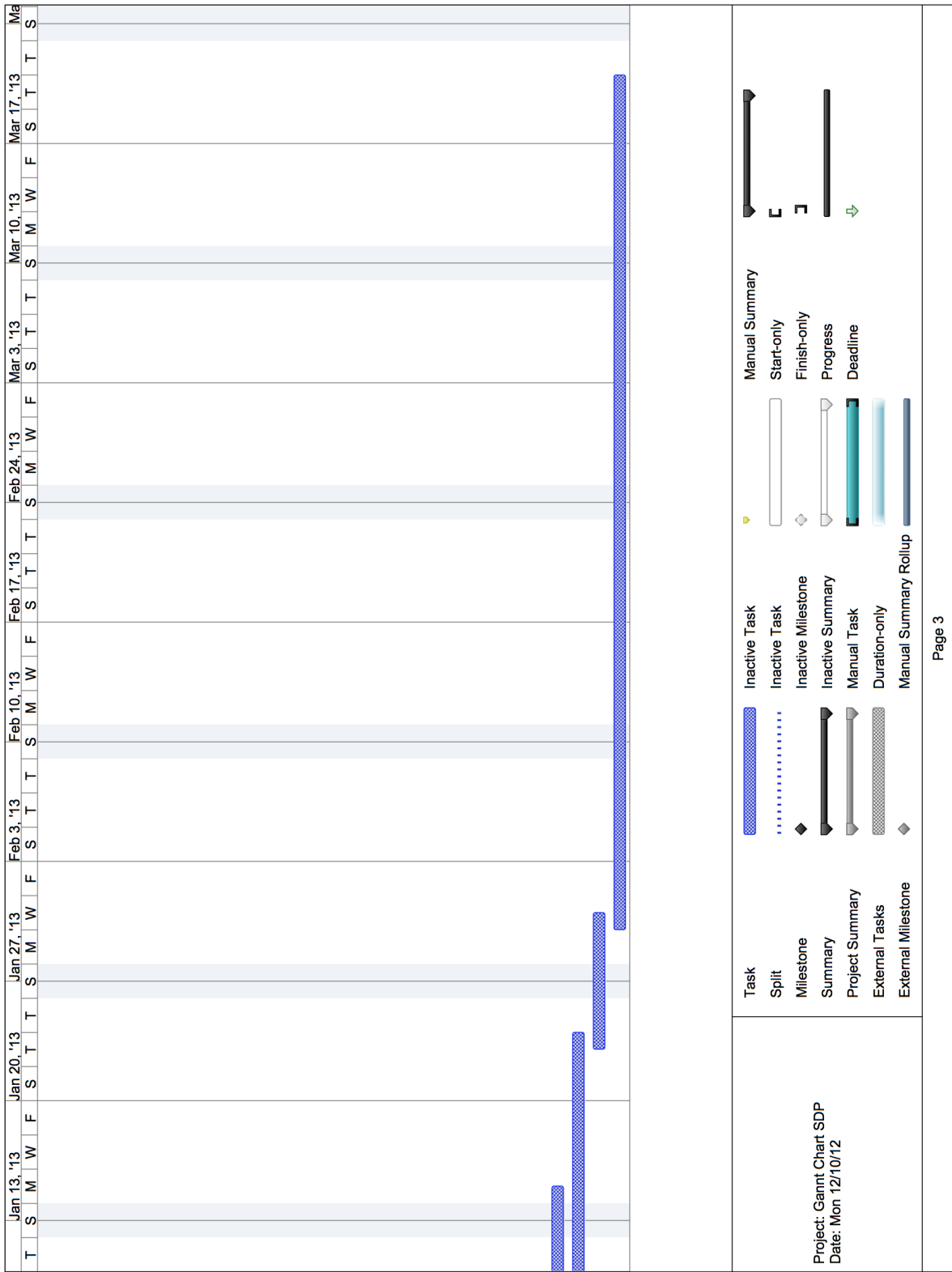

# Appendix

## Appendix I – Initial and Preliminary Design

### Initial Design Concept

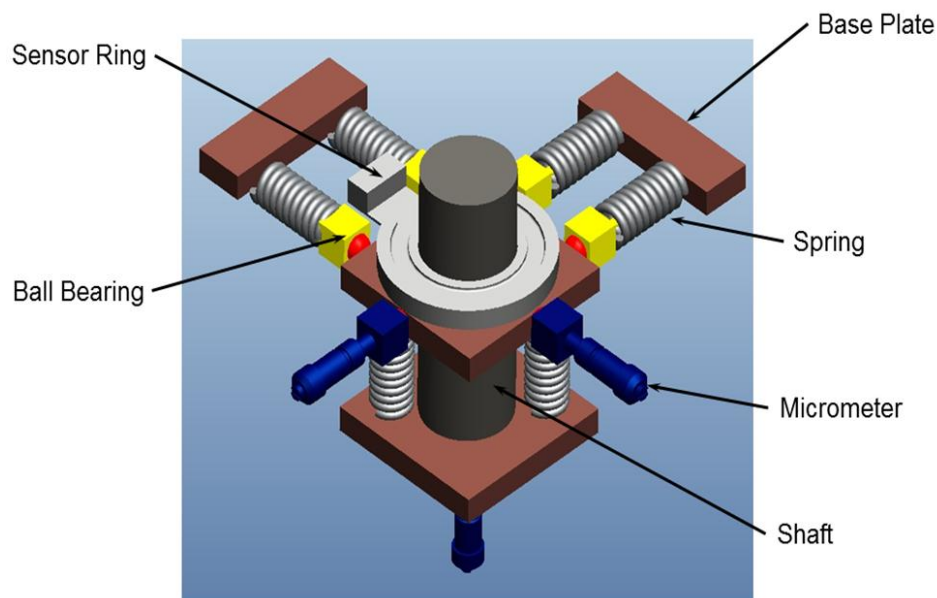

Figure A1 - CAD of initial design concept

At first glance, the testing stage looked promising. Uniaxial displacement was possible using the micrometer heads for locomotion and ball bearings to limit the displacement to the axis through the micrometer. The third direction would be tested using the assembly on the bottom-side of the stage. The total displacement would never exceed 400 microns (about 4 average human hairs). The displacement is not an issue however with the ball bearings on the sides and bottom of the test stage. When one direction of testing is engaged, the roller bearings let the stage roll effortlessly in the desired direction.

What appealed most about this design was the fact that it does create three measurable positions of displacement, added that all are directionally independent of each other. Also appealing, was the likelihood of a relatively low cost of manufacture. This however is true only because the entire test fixture would have to be machined by hand. Turbocor has imposed a minimum accuracy of 1-3 micrometers, which without expensive machinery, is extremely difficult to accomplish. That being said, the low cost of manufacturing proves to be a downfall of this design. There is no need to reinvent the wheel when there are commercially available linear stages that are more than capable of achieving this magnitude of accuracy. Also adding to the ineffectiveness of this design is that there no solution for backlash that may occur during testing, which is the main reason Turbocor has proposed this design project in the first place. Several changes were implemented to correct these issues.

## Corrected Design Concept

During the design phase of the initial design concept, it was clear that a solution was needed to resolve the issue of inaccuracy and backlash. The most apparent cause of the possible backlash and inaccuracy was the construction of the testing stage and its components. Machining these parts to be accurate to 1 micron would be too difficult and time consuming. Therefore the design took a turn towards commercially available linear stages. The stage of interest was the New Focus Gothic-Arch 65-mm Platform Translation Stage, part number 9063-XYZ.

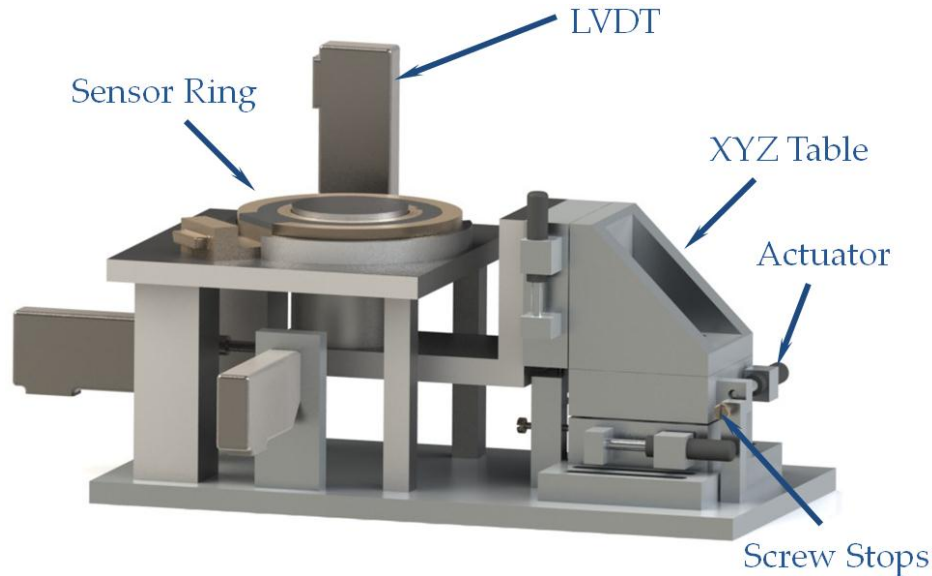

Figure A2 - Corrected linear test fixture CAD

This corrected design features the compounded product from New Focus, which consists of three uniaxial stages mounted on top of one another to create displacement in three directions. Micrometer heads handle the actuation once again, but mechanical stop are shown, and their role was to limit the movement of each platform to the maximum of 400 micrometers. Mounted to the vertical linear stage is the testing fixture that consists of the mock shaft and holding stage for placement of the sensor ring. The vertical stage is mounted using an attachment shown in the image, which shifts directly with the actuation of the micrometer heads. The testing fixture comes off the attached vertical stage and holds the mock shaft. The mock shaft is moved inside the sensor ring to create uniaxial displacement.

The three stage fixture is capable of testing each axis of sensors independently because of its ability to return to the starting position via the spring loaded platforms. Also seen in the image are LVDT's. This is the solution to the backlash that may occur during testing. When the testing stage is displaced, the LVDT's will very accurately track every step of movement that occurs. The resolution of the LVDT's donated by Turbocor is 0.5 microns. This is more than enough to meet Turbocor's needs of 1-3 microns. On the under-side, an additional piece does the testing for the axial movement sensor.

The accuracy issue is resolved with the commercial linear stage with this corrected design, which leads to the benefits of the design as a whole. Precision in testing the sensor ring is imperative, and this design has the capability of being extremely precise. Linear displacement is once

again uniaxial, and any backlash is immediately observed by the LVDT's and errors in measurement are accounted for. However, significant drawbacks still exist in this design. The commercial linear stage brings our estimated cost upwards of \$2000, not practical if multiple fixtures are to be built. Also hindering the development of this test fixture design is the fact that all of the testing is still completely manual. Although the commercial linear stage is extremely accurate, automating it is close to impossible without investing in \$900 Pico motors for each movement axis.

## **Final Design Proposal**

In the final stage of the design process the most important task was to seek alternate means of accurately and precisely displacing the testing stage a distance equal to the thickness of 4 human hairs lying next to each other. The solution we discovered was spring steel.

In an effort to drastically reduce the cost of manufacturing the testing fixture, the commercial linear stage needed to be left behind. A completely redesigned testing fixture and sensor ring stage were developed to accompany the new means of movement control. Also with the conversion from commercial linear stage to spring steel test stage, the need for three LVDT's no longer exists. Thus, reducing the cost even more.

The final test fixture, without commercial stage, is now capable of being fully automated. To do this, air cylinder pistons are to be the primary means of actuation. Again there will be mechanical stops to limit the displacement to the desired amount. The air pistons must be able to provide enough force to overcome the movement restricting force the spring steel has on the test stage. Several test simulations were conducted using Solid Works software to determine the necessary force requirement.

The air pistons provide actuation for testing the sensors in the radial X and Y directions. However, the axial sensor in the Z direction must remain manual. The fixture utilizes a separate mechanism to perform this test. The mechanism is displaced using a micrometer. No LVDT is needed due to the fact the displacement is directly through the micrometer head.

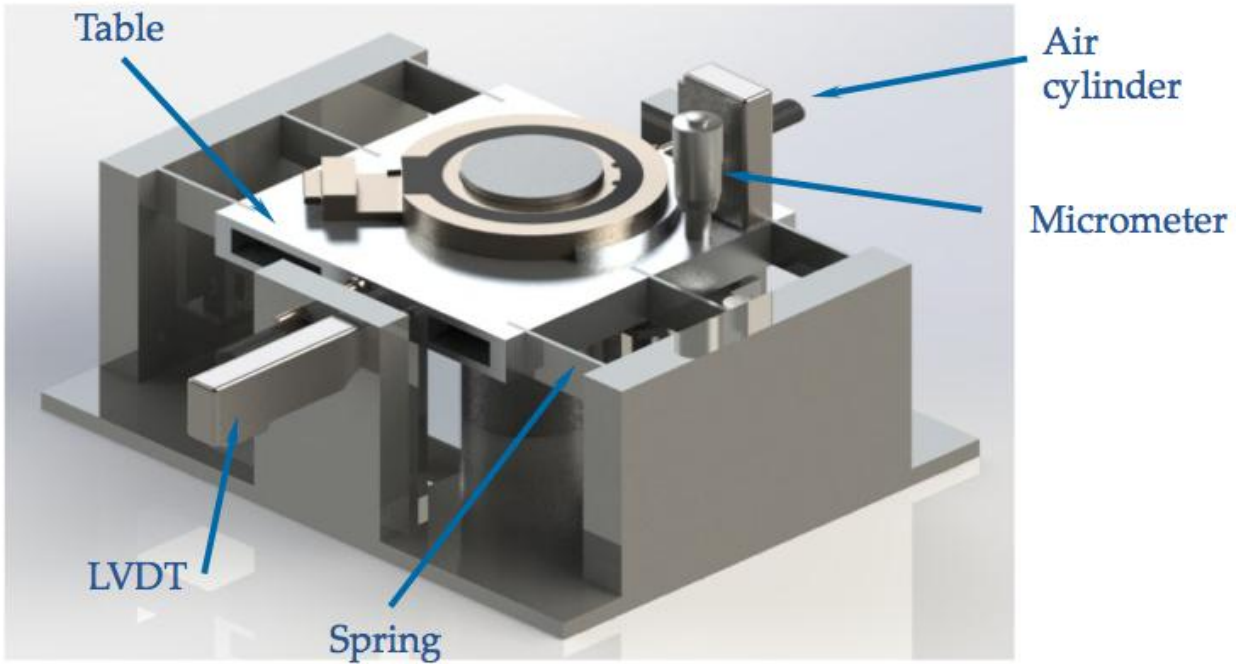
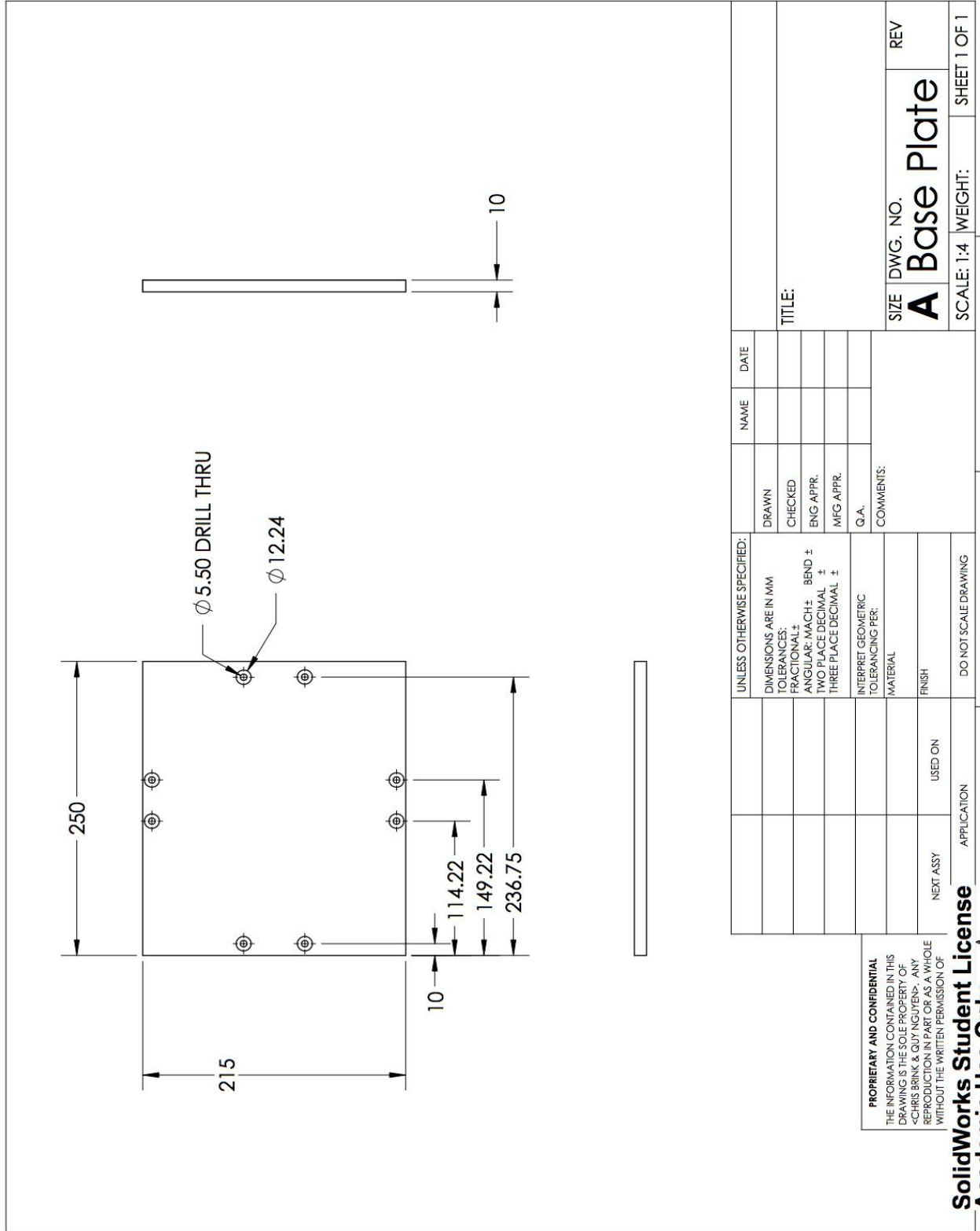

Figure A3 - Final Test Fixture Design

The finalized test fixture design boasts many improvements over the previous designs. The manufacturing cost is extensively reduced without the commercial linear stage. Also reducing the overall cost is the need for only two LVDT's. Turbocor has generously donated two already so there is no longer a need for a third \$600 LVDT. Independent linear displacement is also easily executed with this fixture design utilizing the spring steel for movement restriction. And finally, the testing time is greatly reduced by performing the test using the two air cylinder pistons.

# Appendix II – Part Drawing



**PROPRIETARY AND CONFIDENTIAL**  
 THE INFORMATION CONTAINED IN THIS DRAWING IS THE SOLE PROPERTY OF <CHRIS BRINK & GUY NGUYEN>. ANY REPRODUCTION IN PART OR AS A WHOLE WITHOUT THE WRITTEN PERMISSION OF

**SolidWorks Student License**  
**Academic Use Only**

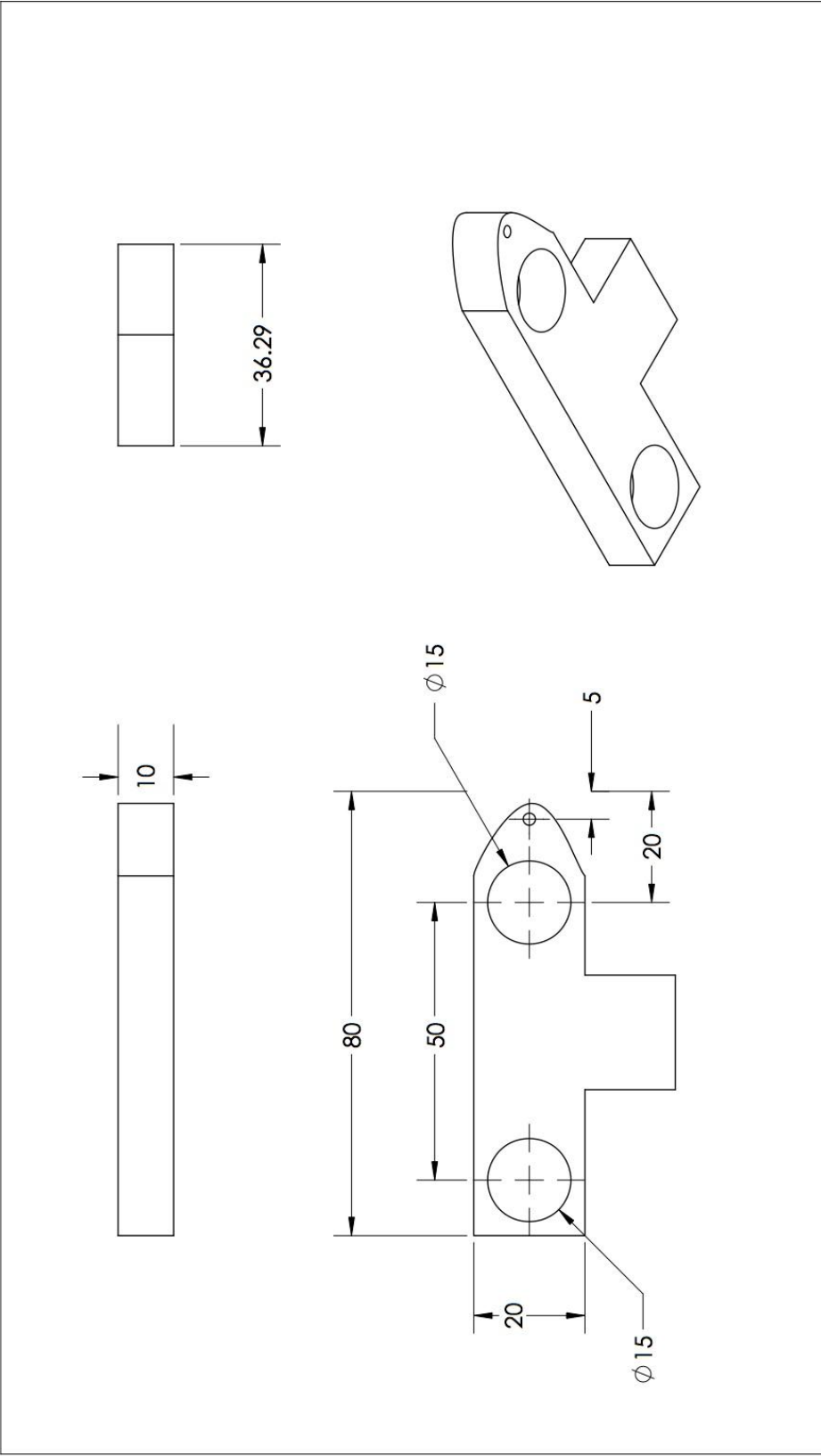

UNLESS OTHERWISE SPECIFIED:		NAME	DATE
DIMENSIONS ARE IN MM	DRAWN		
TOLERANCES:	CHECKED		
FRACTIONAL ±	ENG APPR.		
ANGULAR: MACH ±	MFG APPR.		
TWO PLACE DECIMAL ±	Q.A.		
THREE PLACE DECIMAL ±	COMMENTS:		
INTERPRET GEOMETRIC TOLERANCING PER:			
MATERIAL			
FINISH			
NEXT ASSY	USED ON		
APPLICATION	DO NOT SCALE DRAWING		

SIZE	DWG. NO.	REV
<b>A</b>	Z_rod_bracket	

  

SCALE: 1:1	WEIGHT:	SHEET 1 OF 1
		1

**PROPRIETARY AND CONFIDENTIAL**  
 THE INFORMATION CONTAINED IN THIS DRAWING IS THE SOLE PROPERTY OF <CHRIS BRINK & QUY NGUYEN>. ANY REPRODUCTION IN PART OR AS A WHOLE WITHOUT THE WRITTEN PERMISSION OF

**SolidWorks Student License Academic Use Only**



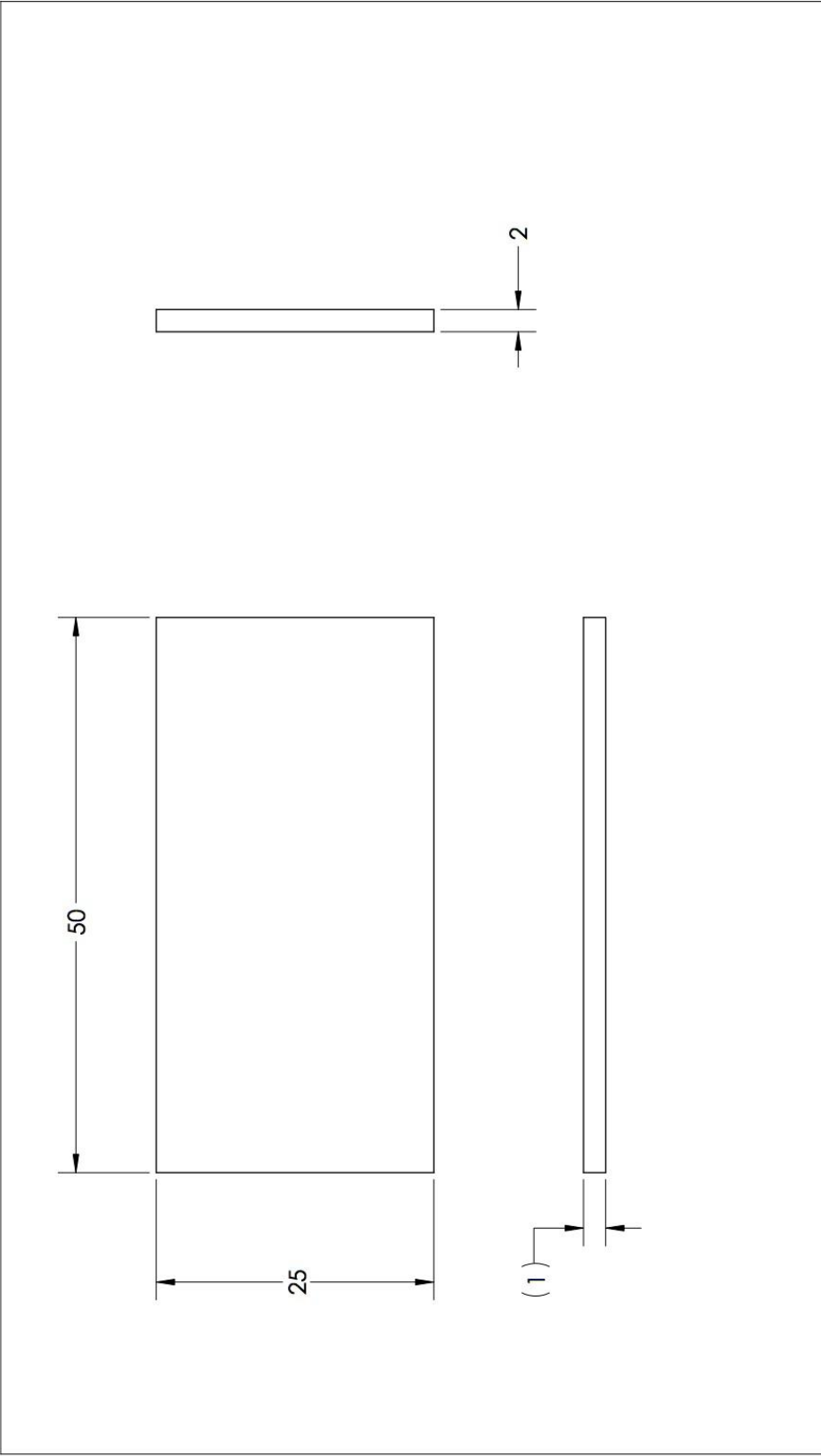

UNLESS OTHERWISE SPECIFIED:		NAME	DATE
DIMENSIONS ARE IN MM	DRAWN		
TOLERANCES:	CHECKED		
FRACTIONAL ±	ENG APPR.		
ANGULAR: MACH ±	MFG APPR.		
BEND ±	Q.A.		
TWO PLACE DECIMAL ±	COMMENTS:		
THREE PLACE DECIMAL ±			
INTERPRET GEOMETRIC TOLERANCING PER:			
MATERIAL			
FINISH			
USED ON			
NEXT ASSY			
APPLICATION			

**PROPRIETARY AND CONFIDENTIAL**  
 THE INFORMATION CONTAINED IN THIS DRAWING IS THE SOLE PROPERTY OF <CHRIS BRINK & QUY NGUYEN>. ANY REPRODUCTION IN PART OR AS A WHOLE WITHOUT THE WRITTEN PERMISSION OF

SIZE DWG. NO. **A** Steel\_Springs REV  
 SCALE: 2:1 WEIGHT: SHEET 1 OF 1

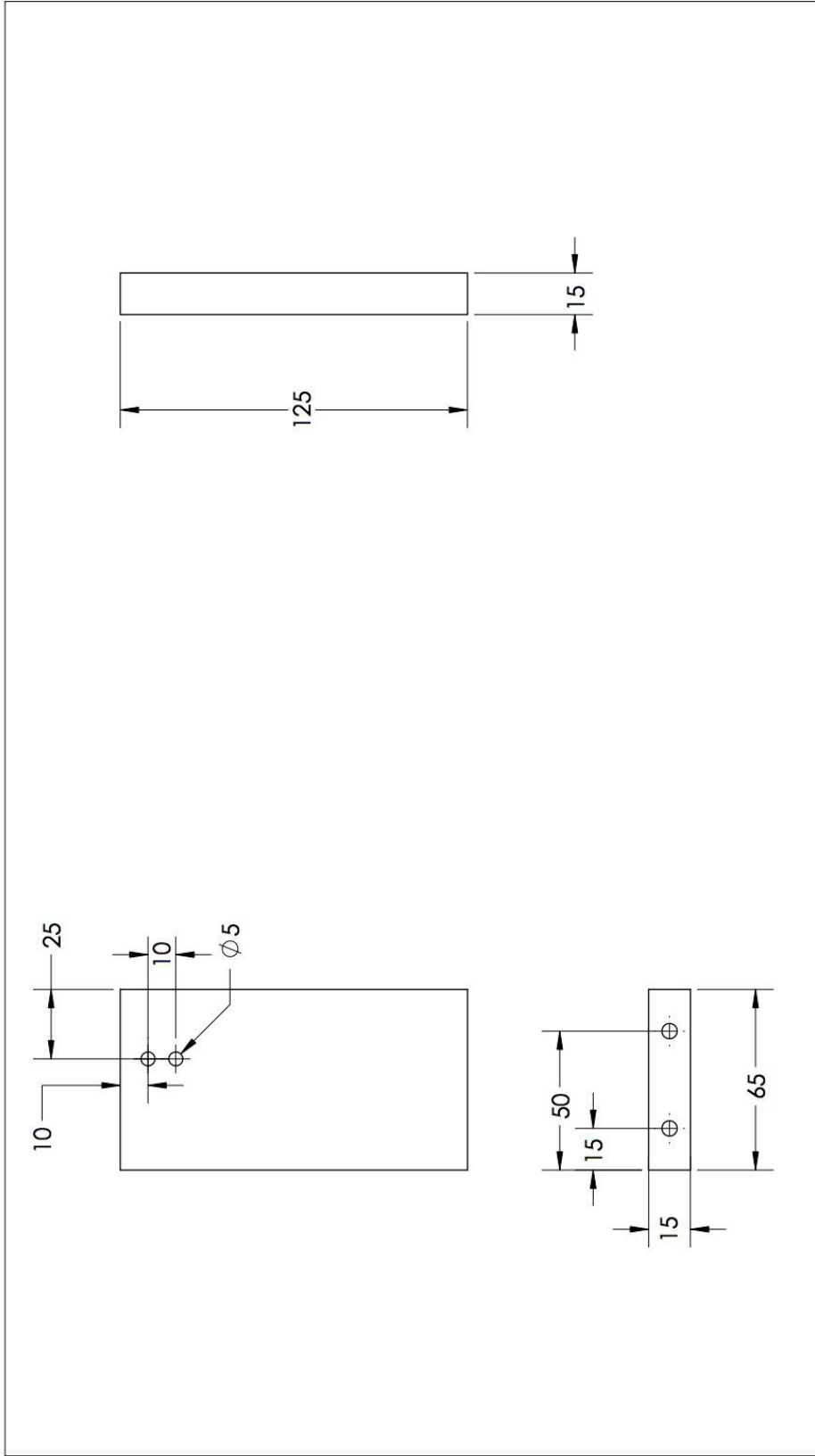

**PROPRIETARY AND CONFIDENTIAL**  
 THE INFORMATION CONTAINED IN THIS DRAWING IS THE SOLE PROPERTY OF <CHRIS BRINK & GUY NGUYEN>. ANY REPRODUCTION IN PART OR AS A WHOLE WITHOUT THE WRITTEN PERMISSION OF

UNLESS OTHERWISE SPECIFIED:		NAME	DATE
DIMENSIONS ARE IN MM		DRAWN	
TOLERANCES:		CHECKED	
FRACTIONAL $\pm$		ENG APPR.	
ANGULAR: MACH $\pm$ BEND $\pm$		MFG APPR.	
TWO PLACE DECIMAL $\pm$		Q.A.	
THREE PLACE DECIMAL $\pm$		COMMENTS:	
INTERPRET GEOMETRIC TOLERANCING PER:			
MATERIAL			
FINISH			
NEXT ASSY		USED ON	
APPLICATION		DO NOT SCALE DRAWING	
4		3	2
1		1	
SIZE		DWG. NO.	
A		Small Side Plate 2	
SCALE: 1:2		WEIGHT:	
SHEET 1 OF 1		REV	

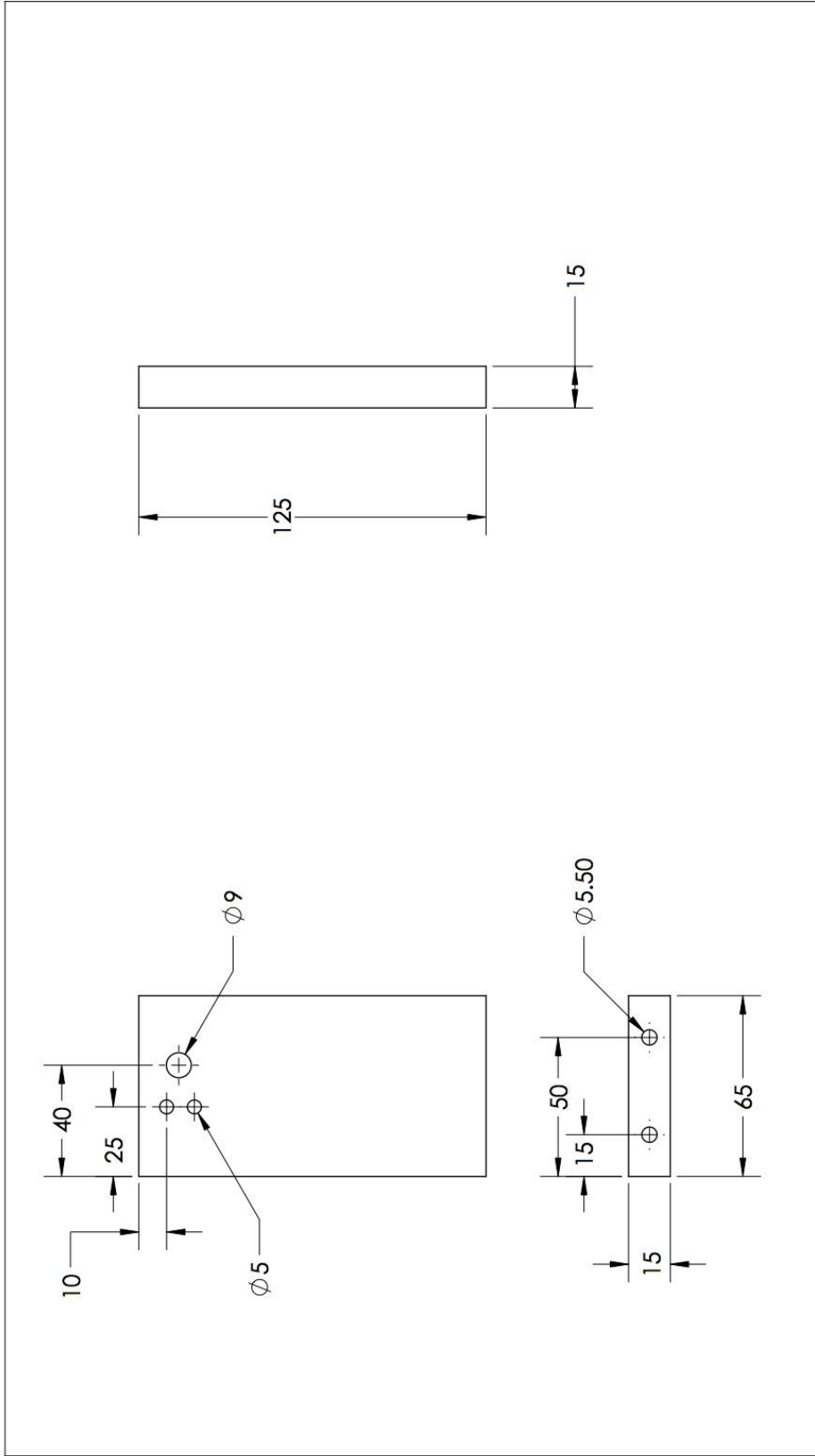

UNLESS OTHERWISE SPECIFIED:		NAME	DATE
DIMENSIONS ARE IN MM		DRAWN	
TOLERANCES:		CHECKED	
FRACTIONAL $\pm$		ENG APPR.	
ANGULAR: MACH $\pm$ BEND $\pm$		MFG APPR.	
TWO PLACE DECIMAL $\pm$		Q.A.	
THREE PLACE DECIMAL $\pm$		COMMENTS:	
INTERPRET GEOMETRIC TOLERANCING PER:			
MATERIAL			
FINISH			
NEXT ASSY	USED ON		
APPLICATION		DO NOT SCALE DRAWING	
4		3	
1		2	
1		1	

**PROPRIETARY AND CONFIDENTIAL**  
 THE INFORMATION CONTAINED IN THIS DRAWING IS THE SOLE PROPERTY OF <CHRIS BRINK & GUY NGUYEN>. ANY REPRODUCTION IN PART OR AS A WHOLE WITHOUT THE WRITTEN PERMISSION OF

SIZE DWG. NO. **A**  
**Small side plate 1**  
 REV

SCALE: 1:2 WEIGHT: SHEET 1 OF 1

**SolidWorks Student License**  
**Academic Use Only**

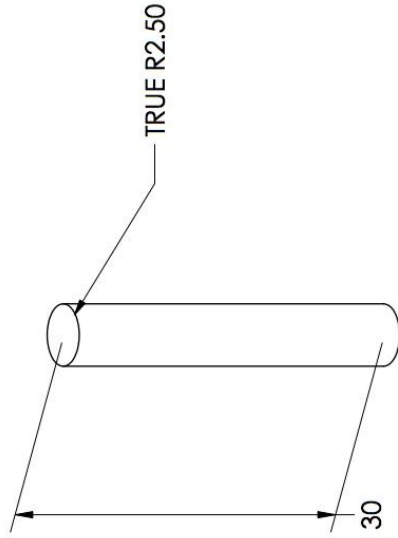

**PROPRIETARY AND CONFIDENTIAL**  
 THE INFORMATION CONTAINED IN THIS DRAWING IS THE SOLE PROPERTY OF <CHRIS BRINK & QUY NGUYEN>. ANY REPRODUCTION IN PART OR AS A WHOLE WITHOUT THE WRITTEN PERMISSION OF

UNLESS OTHERWISE SPECIFIED:		NAME	DATE
DIMENSIONS ARE IN MM	DRAWN		
TOLERANCES:	CHECKED		
FRACTIONAL ±	ENG APPR.		
ANGULAR: MACH ± BEND ±	MFG APPR.		
TWO PLACE DECIMAL ±	Q.A.		
THREE PLACE DECIMAL ±	COMMENTS:		
INTERPRET GEOMETRIC TOLERANCING PER:			
MATERIAL			
FINISH			
NEXT ASSY	USED ON		
APPLICATION	DO NOT SCALE DRAWING		

SIZE DWG. NO. REV  
**A** Slide\_rod  
 SCALE: 2:1 WEIGHT: SHEET 1 OF 1

**SolidWorks Student License**  
**Academic Use Only**

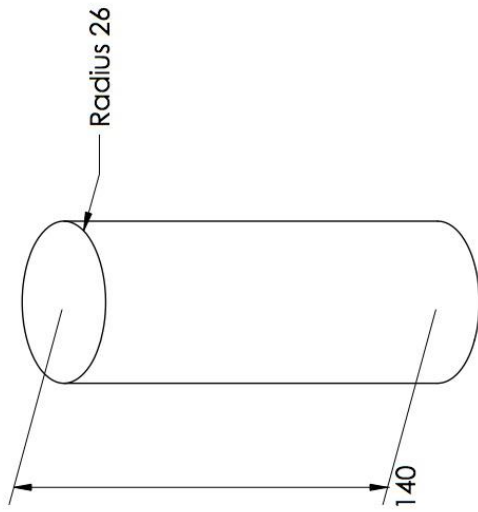

**PROPRIETARY AND CONFIDENTIAL**  
 THE INFORMATION CONTAINED IN THIS DRAWING IS THE SOLE PROPERTY OF <CHRIS BRINK & QUY NGUYEN>. ANY REPRODUCTION IN PART OR AS A WHOLE WITHOUT THE WRITTEN PERMISSION OF

UNLESS OTHERWISE SPECIFIED:		NAME	DATE
DIMENSIONS ARE IN MM	DRAWN		
TOLERANCES:	CHECKED		
FRACTIONAL ±	ENG APPR.		
ANGULAR: MACH ±	MFG APPR.		
TWO PLACE DECIMAL ±	Q.A.		
THREE PLACE DECIMAL ±	COMMENTS:		
INTERPRET GEOMETRIC TOLERANCING PER:			
MATERIAL			
FINISH			
NEXT ASSY	USED ON		
APPLICATION	DO NOT SCALE DRAWING		
4	3	2	1
SIZE DWG. NO. <b>A</b> Shaft		REV	
SCALE: 1:2		WEIGHT: SHEET 1 OF 1	

**SolidWorks Student License Academic Use Only**



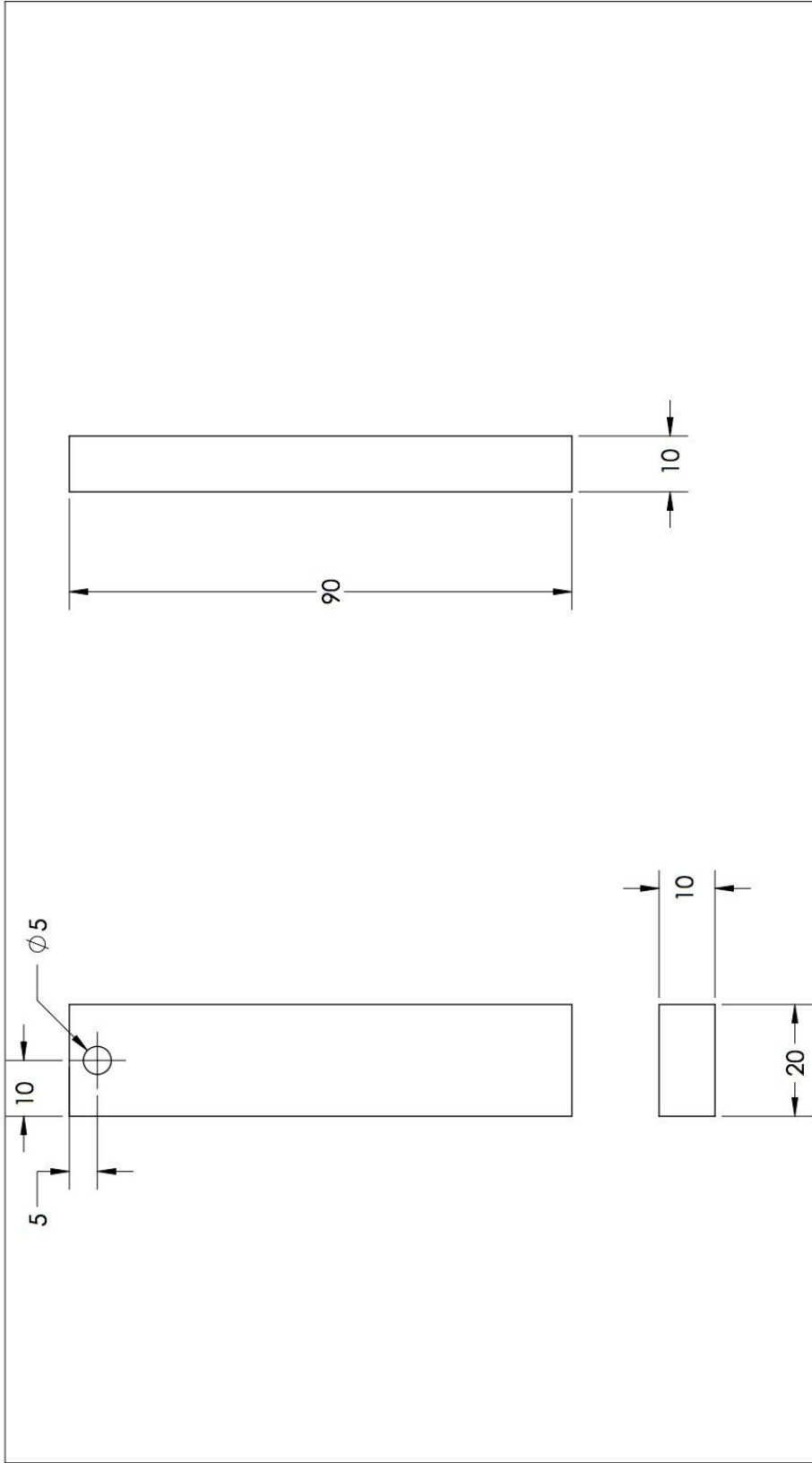

UNLESS OTHERWISE SPECIFIED:		NAME	DATE
DIMENSIONS ARE IN MM		DRAWN	
TOLERANCES:		CHECKED	
FRACTIONAL ±		ENG APPR.	
ANGULAR: MACH ±		MFG APPR.	
BEND ±		Q.A.	
TWO PLACE DECIMAL ±		COMMENTS:	
THREE PLACE DECIMAL ±			
INTERPRET GEOMETRIC TOLERANCING PER:			
MATERIAL			
FINISH			
NEXT ASSY		USED ON	
APPLICATION			
DO NOT SCALE DRAWING			

**PROPRIETARY AND CONFIDENTIAL**  
 THE INFORMATION CONTAINED IN THIS DRAWING IS THE SOLE PROPERTY OF <CHRIS BRINK & QUY NGUYEN>. ANY REPRODUCTION IN PART OR AS A WHOLE WITHOUT THE WRITTEN PERMISSION OF

SIZE DWG. NO. **A** Guide  
 TITLE: **Guide**  
 SCALE: 1:1 WEIGHT: SHEET 1 OF 1

**SolidWorks Student License Academic Use Only**

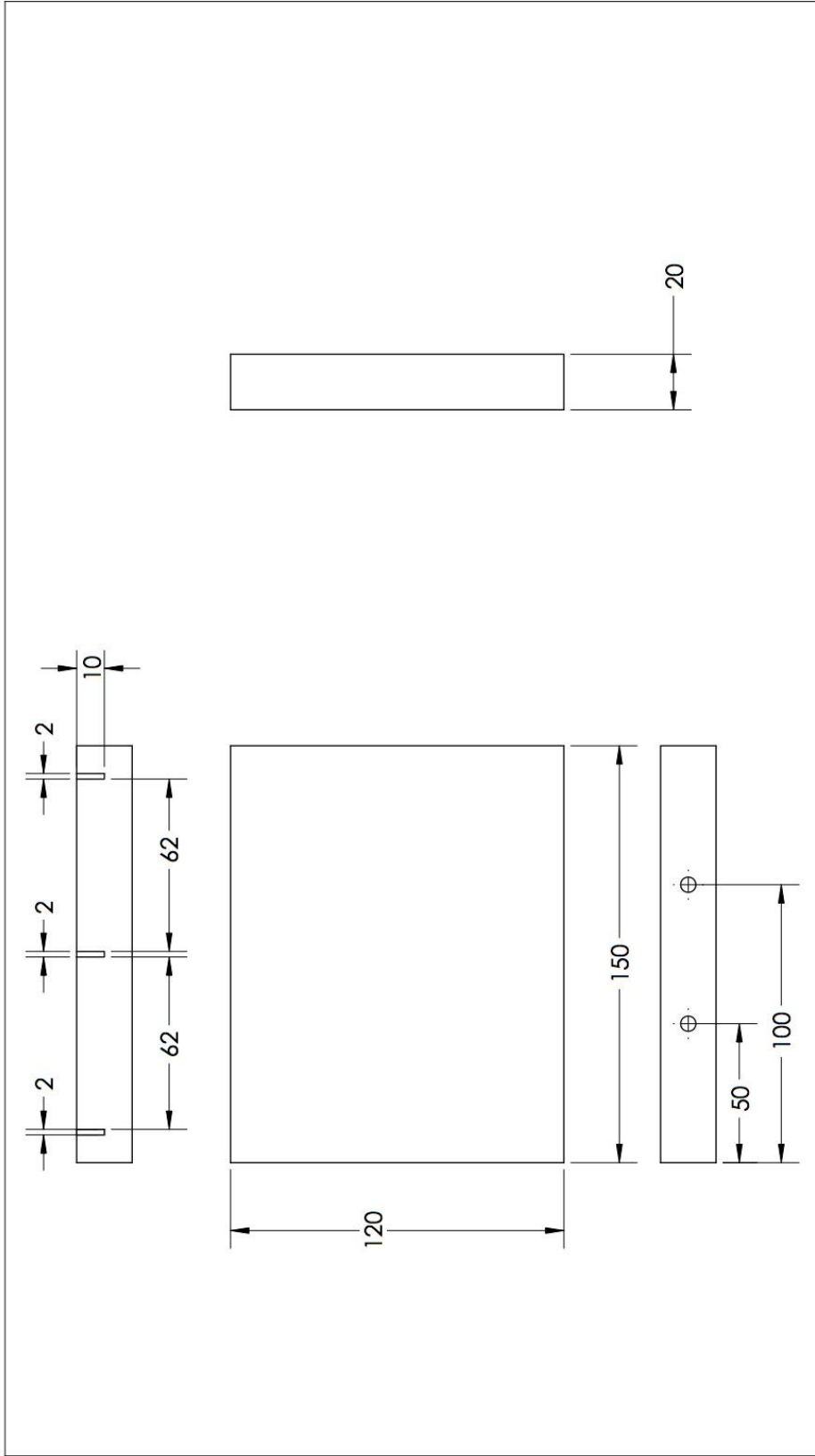

UNLESS OTHERWISE SPECIFIED:		NAME	DATE
DIMENSIONS ARE IN MM	DRAWN		
TOLERANCES:	CHECKED		
FRACTIONAL ±	ENG APPR.		
ANGULAR: MACH ±	MFG APPR.		
TWO PLACE DECIMAL ±	Q.A.		
THREE PLACE DECIMAL ±	COMMENTS:		
INTERPRET GEOMETRIC TOLERANCING PER:			
MATERIAL			
FINISH			
NEXT ASSY	USED ON		
APPLICATION	DO NOT SCALE DRAWING		

**PROPRIETARY AND CONFIDENTIAL**  
 THE INFORMATION CONTAINED IN THIS DRAWING IS THE SOLE PROPERTY OF <CHRIS BRINK & QUY NGUYEN>. ANY REPRODUCTION IN PART OR AS A WHOLE WITHOUT THE WRITTEN PERMISSION OF

SIZE DWG. NO. **A** Big Side Plate REV  
 SCALE: 1:2 WEIGHT: SHEET 1 OF 1