



Spring Midterm Presentation



FCAAP: AIAA Design Build Fly

Instructor

Dr. Kamal Amin

Project Advisors

Dr. Farrukh Alvi

Dr. Chiang Shih

Sponsor

FCAAP

TEAM 16: Lee Becker – Jordan Benezra – Terry Thomas – Will Watts

[2/12/13]





Presentation Outline



- Fall Review
 - Overview of Competition
 - Previous Design
- Midpoint Review
 - Current Prototype
 - Design Changes
 - Fuselage
 - Internal Store Attachment Method
 - Build Process
 - Wing
 - Internal / External Stores
- Future Work
- Schedule
- Budget



Competition Overview



- Held in Tucson, Arizona in April, 2013
- Score based upon Three flight missions, aircraft parameters, and written report.
- Mission 1: Max completed laps in given time
- Mission 2: Max internal stores for 3 laps
- Mission 3: Random missile configuration
3 laps, minimum time
- Written Report: 60-Page maximum, Due 2/25/13



Aircraft Specifications



- Wing Span: 78 inches
- Vertical Tail Span: 10.25 inches
- Horizontal Tail Span: 24 inches
- Overall Length:~ 60 inches (flight test dependent)
- Max Empty Weight: 3.5 pounds



Previous Aircraft Prototype

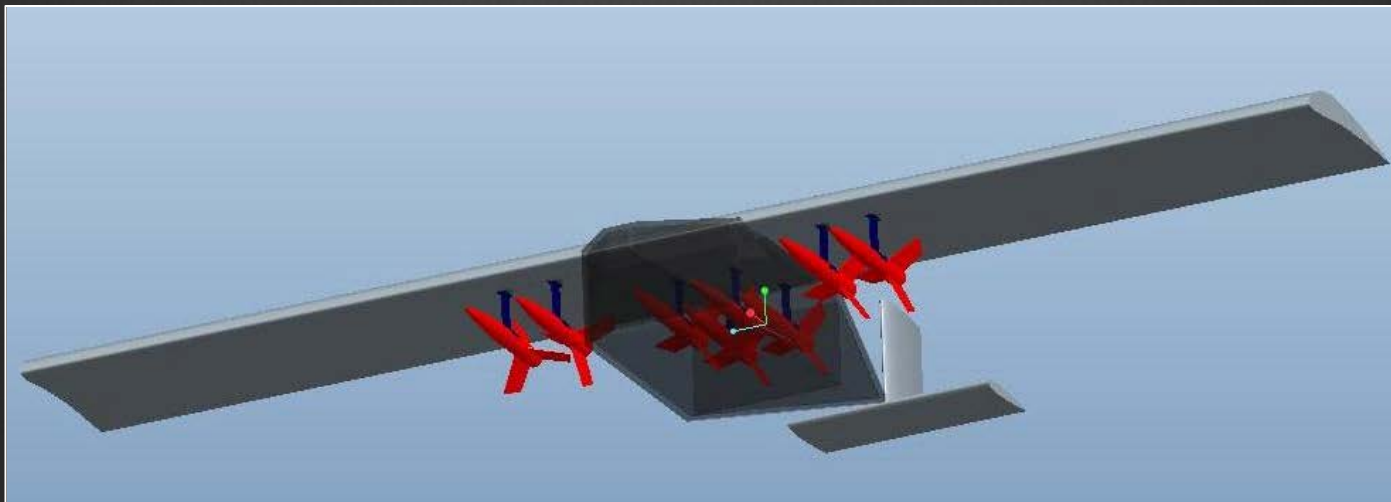
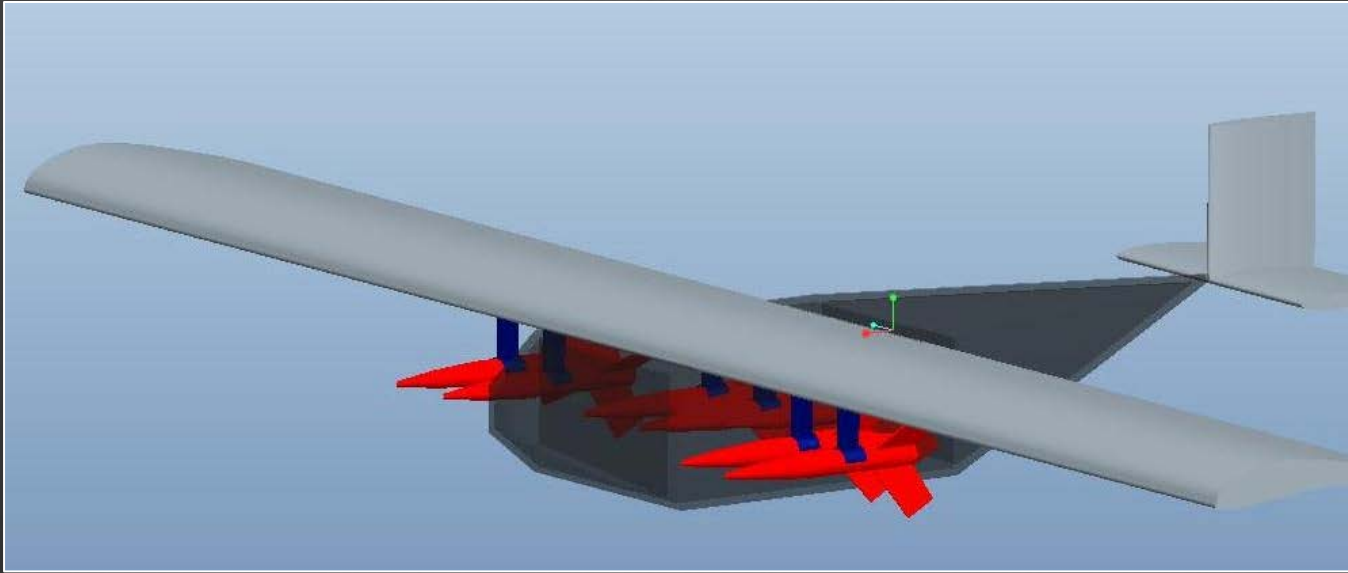



Current Aircraft Prototype

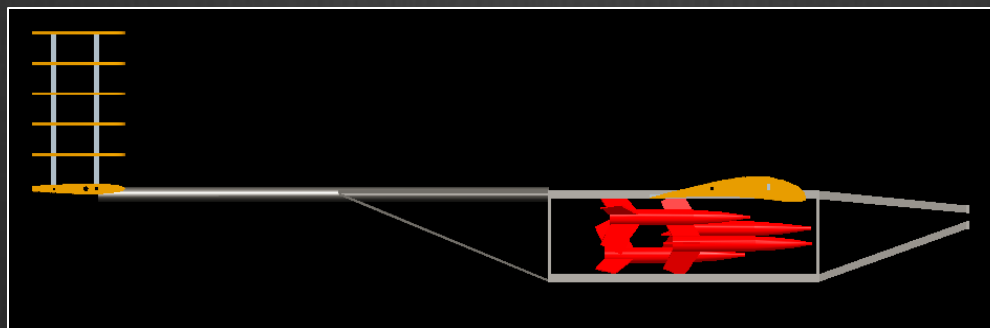
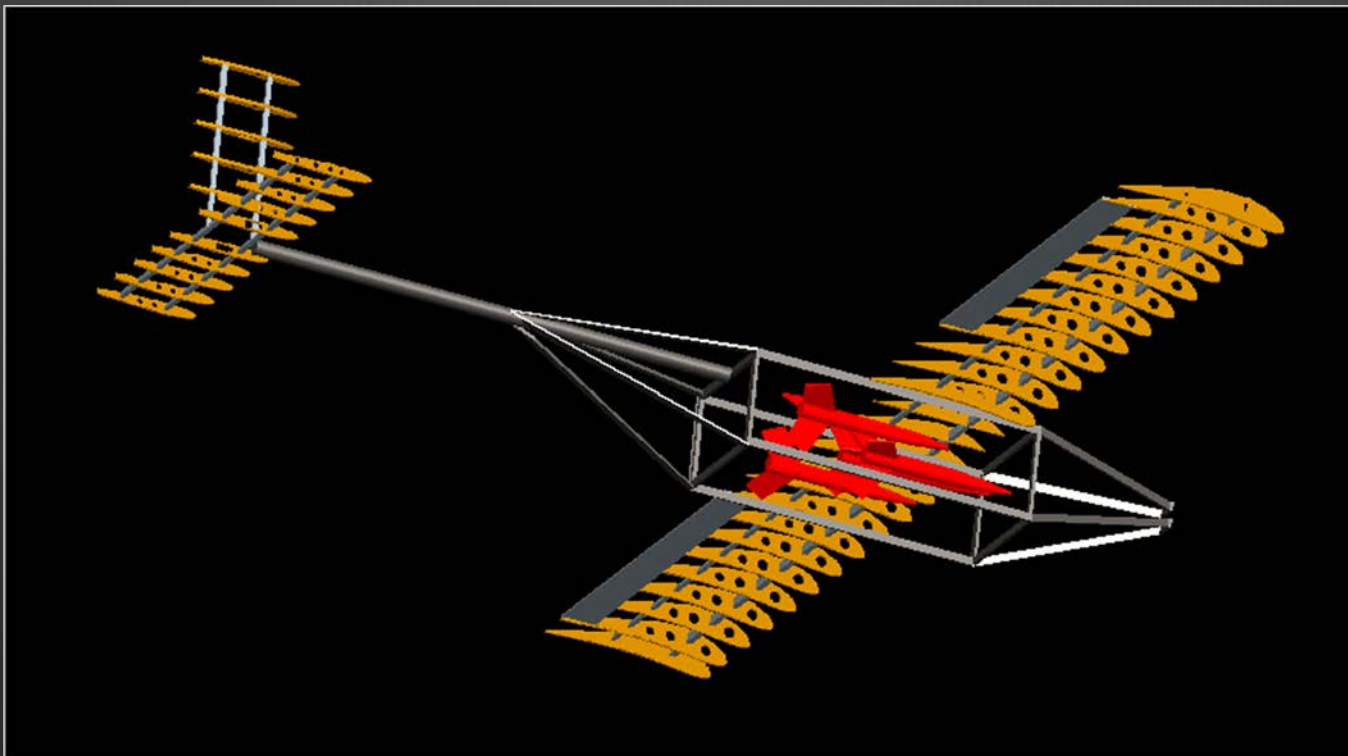



Fuselage Construction



Air-Frame

Carbon Fiber
0.5 x 0.125 inch

Bass Wood
8.0 x 18.0 inch

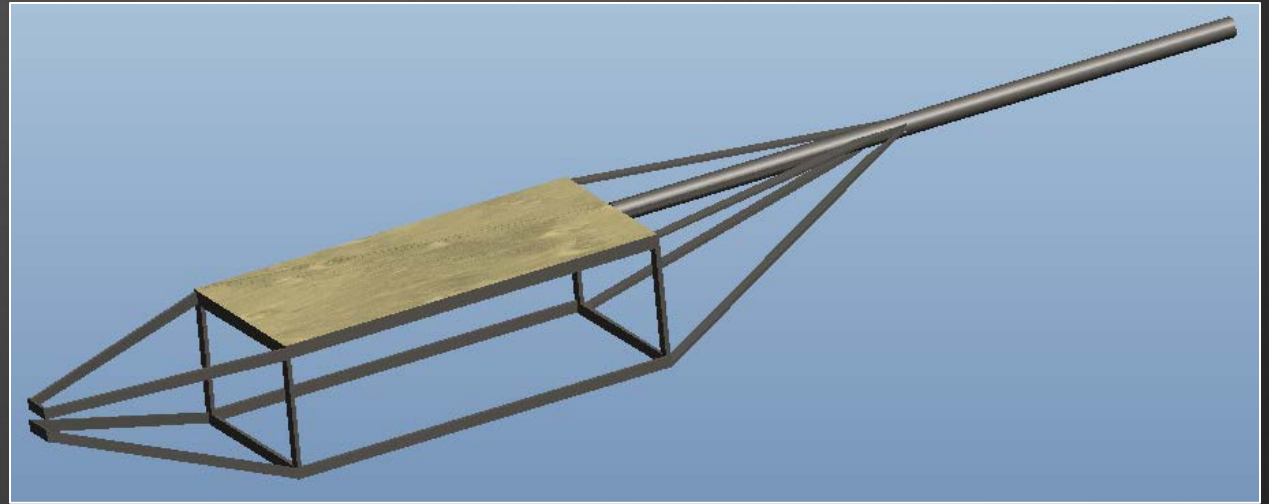

Tail Connection

Carbon Fiber Tube
0.75 inch I.D.

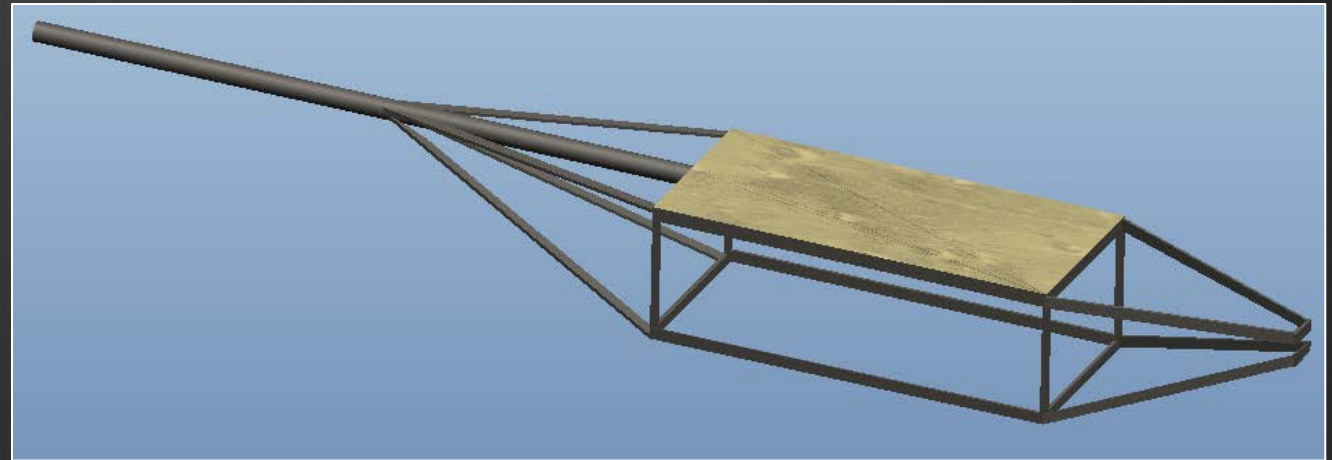

Internal Store Attachment

Light weight plastic tubing

- single piece design eliminates complicated attachment mechanisms
- provides secure grasp on entire outer surface of “Minimax” internal stores
- prevents unwanted axial motion during flight

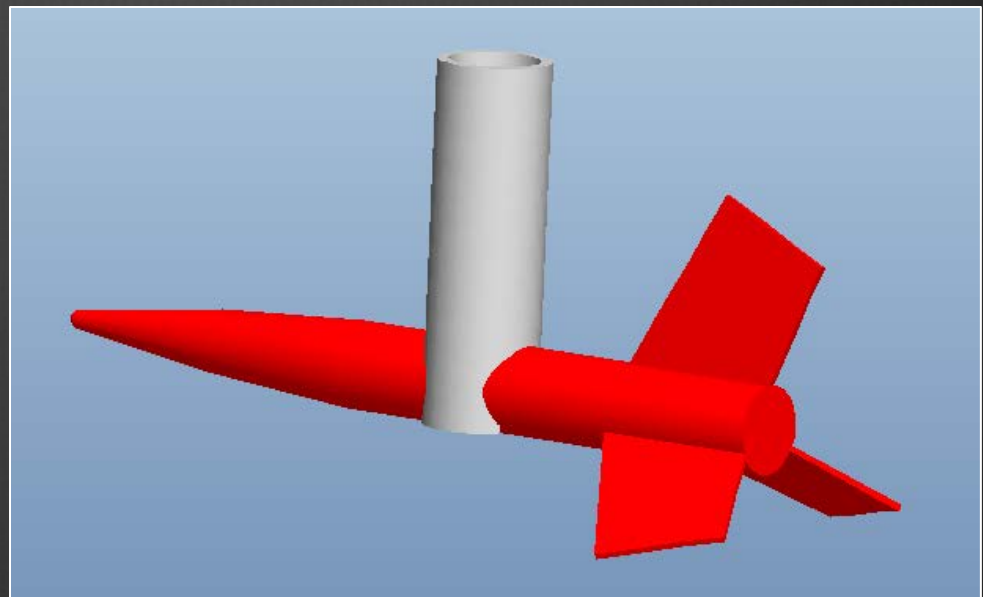
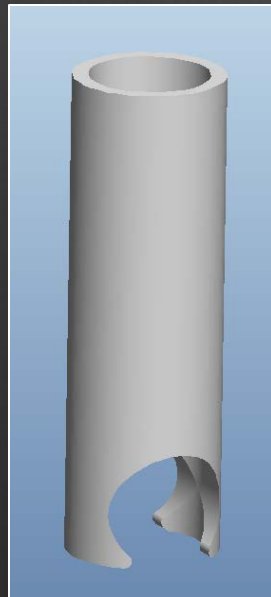



Construction Process





Future Work



Short Term

- Awaiting Carbon fiber shipment to begin fuselage construction
- Finish wing fabrication : servo installation, control surfaces and monokote
- Complete external store attachment design
- Finalize competition design report

Long Term

- Complete final prototype and fabricate spare wing/tail
- Flight test and optimization
- Compete successfully!



Schedule

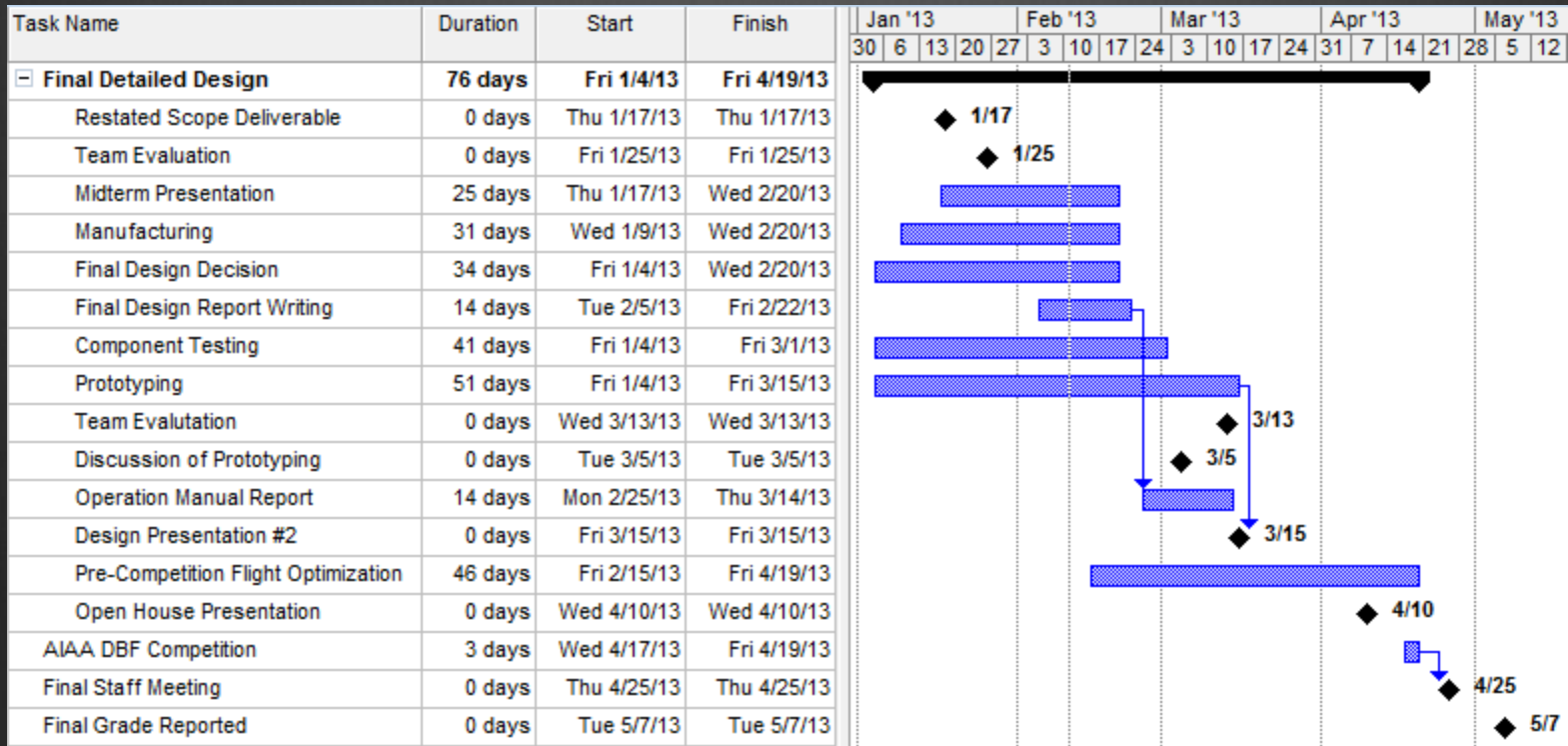



Current Expenditures

Product	Size (inches unless specified) or Product description	Quantity	Unit Price (\$)	Total (\$)
Wood	3X36X1/32	8	0.65	5.2
	3X36X1/16	10	1.21	12.1
	3X36X1/8	6	1.72	10.32
	3X48X1/8	20	1.94	38.8
Carbon Fiber	3mm X 750 mm	2	1.49	2.98
	0.25x0.25x80	2	5.35	10.7
	0.25x0.25x24	3	19.8	59.4
	ID 0.75 x 48	1	54	54
	0.125x0.5x48	8	13.5	108
Motors	860kv 22A	1	15.58	15.58
	1320kv	1	20.15	20.15
	1100kv	1	9.34	9.34
Propellers	Various Pitch and Diameter	15	3	45
Servos	Hs 325 Hb	6	12.99	77.94
Model Rockets	Der Red Max	4	12.99	51.96
	Mini Honest John	4	8.49	33.96
	Hi-Flier	2	6.99	13.98
	Mini Max	4	8.99	35.96
Hardware	Nuts/Bolts washers misc.			30
	Batteries/ Charger/ Wires			40
	Tools needed for fabrication			60
	Monokote	3	13	39
Shipping	Various Items			300
Total Spent to Date				1074.37



Questions

