

Final Design Report (Fall Semester)

EML4551-C Senior Design, Fall 2012, Deliverable

AIAA Design Build Fly Competition

Group # 16 (G16)

Team Publisher – Lee F. Becker

Team Leader – Jordan Benezra

Meeting Coordinator – Terry Thomas

Team Treasurer – Will S. Watts

Sponsor:



Advisors:

Dr. Alvi

Dr. Shih

Instructor: Dr. Amin

Submission Date: 12/11/12



Table of Contents

Executive Summary	4
Management Summary:	5
Objective/Project Scope	6
Needs Assessment	6
Product Specifications	10
Scoring Analysis	10
Conceptual Design	14
Figures of Merit	14
Wing Configuration	15
Fuselage Configuration	16
Tail Configuration	17
Engine Configuration	18
Landing Gear Configuration	19
Payload Configuration	20
Option 1	21
Option 2	22
Option 3	23
Wing Design	24
Airfoil Selection	24
Wing Geometry	28
Tail Design	29
Airfoil Selection	29
Tail Geometry	30
Control Surface Design	32
Propulsion System	33
Motor Selection	35
Propeller Selection	35
Electronics and Controls	36
Transmitter and Receiver	36
Servos	37

Batteries.....	37
Controls Battery Pack	37
Motor Controller	37
Structures/Materials	38
Materials Selection.....	38
Materials Optimization.....	39
References.....	40
Appendix.....	42

Executive Summary

As seniors at the FAMU-FSU College of Engineering we are granted the opportunity to work on a year-long design project that will put our previously attained knowledge on display to the engineering public. Our team has been selected to compete in a national design competition in which we will design and fabricate a remote-operated aircraft for submission into the AIAA Design/Build/Fly competition. This competition has been ongoing since 1996, and involves a myriad of different technical aptitudes in order to successfully compete. It is sponsored by the American Institute of Aeronautics and Astronautics which is the world's largest technical society dedicated to the global aerospace profession. This year's competition gives students the challenge of designing an aircraft capable of carrying both internal and external payloads, in the form of large model rockets, and the competition will take place on the 19th-21st April, 2013.

In order to properly determine the aircraft's design, the team must consider the individual mission requirements as well as actual scoring equations to produce product specifications for each portion of the plane. The aircraft must be electrically powered, propeller driven and of fixed wing orientation, with a motor circuit power limitation of 20 amps. A takeoff zone of 90 square feet has been chosen by AIAA as the prescribed takeoff distance and there is a predetermined flight path for each of the three missions. Each mission entails a different degree of optimization, ranging from speed of flight to load carrying capacity, and combined with our overall design report will heavily determine the success of our efforts.

After choosing our electric motor, we will begin material analysis based on the desired empty weight of our aircraft. Given the predetermined length of the takeoff area, we can calculate a range of weight tolerance defined by the lift/thrust capabilities present. This material analysis will narrow down the possible combinations of building material based on strength to weight ratios per material, as well as define the structural weak points of our aircraft design.

Management Summary:

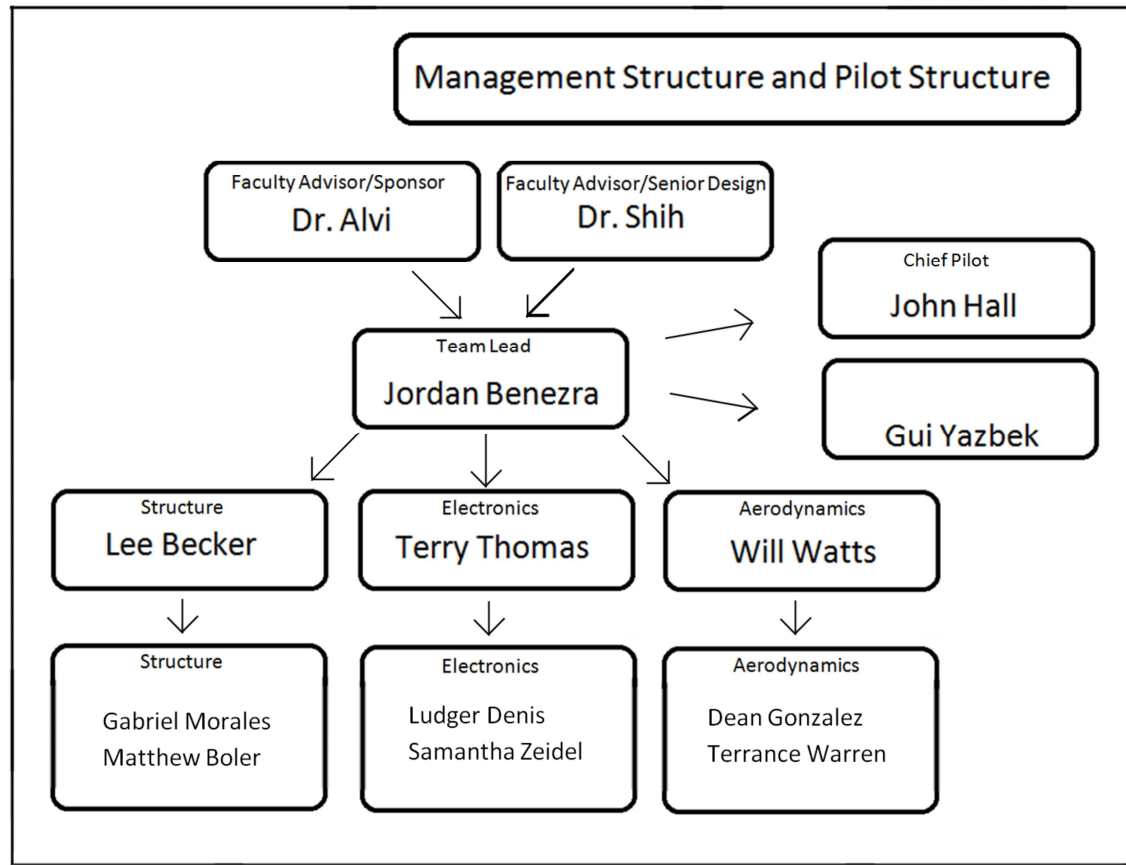

Figure 1- Breakdown for Management of Project

The design team for this UAV is based upon the hub model. The team leader acts as a hub for communication. The faculty advisors serve to help to provide useful feedback on design decisions, and assist in securing funding for the project. They act as mentors and separate themselves from any direct design decision that does not involve safety. The Team leader is also in constant contact with the pilots. In the design phase, the pilots serve as a reference to a depth of practical experience in constructing and operating radio-controlled UAVs. During the time of competition, both will be eligible to operate as they are both AMA certified. The core design team members have a dual responsibility. Each core member of the team has a set of subsystems in which they must make detailed design decisions. The section for aircraft structure is responsible for the layout and weight distributions of the aircraft (including internal and external stores), as well as the material selection, and the manufacturing methods. The electronics section is responsible for design decisions involving communication between user and device, power and controls capabilities, and electronic safety of the unit. The aerodynamics section is responsible for determining necessary lift and balancing moments from all control surfaces on the aircraft. Each core team member for these sections leads a group of underclassmen in these specialized tasks.

Objective/Project Scope

The purpose of our senior design project is to design and fabricate a fixed-wing aircraft suitable to the missions outlined in the AIAA Design Build Fly Competition. The project will be taken on initially with research into the benefits and drawbacks of certain aeronautical component combinations. The focus will then turn to selecting the ideal structural and aerodynamic forms. Once our preferred form is selected, materials will be chosen to minimize weight. While those materials are being delivered, 3d-modeling will take place in order to accurately fabricate the unit. While the modeling is happening, the electrical components will be selected and purchased based upon weight and geometric restrictions of previous selections. Finally, fabrication will take place. The design process must be documented through a technical report covering each aircraft decision and fabrication choice, and the report will be graded along with each of the three flight missions to determine the overall winner of the competition. The three flight missions each entail different desired flight characteristics, mission one is focused on the speed of the aircraft, mission two is concerning internal payload capacity to weight ratio, while the final mission adds external payloads to the flight in a random configuration to be chosen at the competition.

Needs Assessment

General Mission Requirements:

The general requirements for this year's competition have several design constraints and specifications as listed below:

- Can be of any configuration other than rotary wing or lighter than air.
- Must be propeller driven and electric powered by NiCad or NiMH batteries.
- Maximum propulsion battery weight of 1.5 lb.
- Maximum current draw of 20amps.
- Aircraft must take off from a static position for all missions.
- Payloads must be secured; internal payloads must be completely inside the body of the aircraft, and the external payloads must be separated by at least three inches.

The absolute total score will determine the winner of the competition; the equation for the total score is given in equation 1:

$$SCORE = (Written\ Report\ Score) * \left(\frac{Total\ Flight\ Score}{RAC} \right) \quad (1)$$

The total flight score is given in equation 2:

$$Flight\ Score = M1 + M2 + M2 \quad (2)$$

Where M1 is the flight score from mission one, M2 is the flight score from mission 2, and M3 is the flight score from mission 3.

The written score report is determined from the final design report that is due at the latest February 25, 2013, the variable RAC stands for Rated Aircraft Cost and is given by equation 3 :

$$RAC = \frac{\sqrt{EW * SF}}{10} \quad (3)$$

Where EW is the post flight weight with the payloads removed, and SF is the size factor of the aircraft and is determined by equation 4:

$$SF = X_{max} + 2 * Y_{max} \quad (4)$$

Where X_{max} is the longest possible dimension of the aircraft in the direction of flight and Y_{max} is the longest possible dimension perpendicular to the direction of flight.

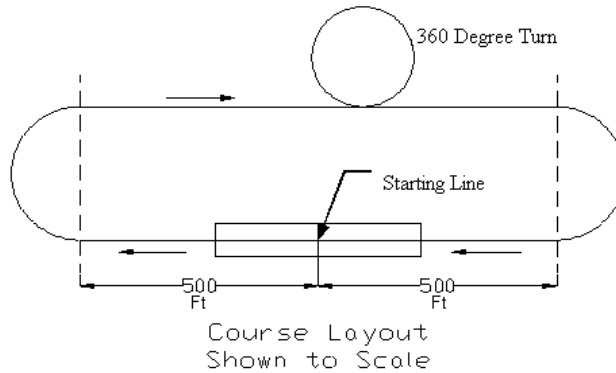

Figure 2 - Flight course for all three missions.

Mission 1 - Short Take-off

In mission one the aircraft which has no payload, must start from a static position and from the time that the throttle is advanced forward the plane has to take off from within a thirty foot square on the runway and complete as many laps as possible; the laps must be completed as set by the flight course described in figure 1. The score for mission one is determined by equation5:

$$M1 = 2 * \left(\frac{N_{Laps\ Flown}}{Max\ N_{Lapsflown}} \right) \quad (5)$$

Where $N_{Laps\ Flown}$ is the number of laps flown by our team and $Max\ N_{Lapsflown}$ is the maximum number of labs flown by any team. From the criteria of mission 1 the aircraft must be light weight and highly maneuverable.

Mission 2 - Stealth Mission

In the second mission, the aircraft must complete a takeoff from the takeoff platform described in mission 1 as well as carry a maximized amount of internal stores. The score for mission two is given in equation 6:

$$M2 = 4 * \left(\frac{N_{Stores\ Flown}}{Max\ N_{Storesflown}} \right) \quad (6)$$

Where $N_{Stores\ Flown}$ is the number of stores flown by our team and $Max\ N_{Storesflown}$ is the maximum number of stores flown by any team. The stores that will be flown for mission 2 are the Estes Model Rocket kit Mini-Max which has dimensions of 9.75 inches in length and 0.98 inches in diameter. From the criteria of mission 2 the aircraft must have room to place stores securely inside the body of the aircraft.

Mission 3 - Strike Mission

In the third mission, the aircraft must takeoff with the same requirements listed in mission one, except a random payload configuration is determined by a roll of dice which is shown in figure 3.

Stores Configurations:

Payload Configuration (roll dice)		1	2	3	4	5	6
Internal	Mini-Max	4	-	2	-	-	-
Left Wing	Mini Honest john	-	-	-	2	-	-
	High Flyer	-	1	-	-	1	1
	Der Red Max	1	1	1	-	1	1
Right Wing	Mini Honest john	-	-	2	2	2	1
	High Flyer	-	1	-	-	-	1
	Der Red Max	1	1	-	-	-	-

Figure 3 – Store Configurations for Mission 3.

Mission three is timed for three laps, the time starts when the throttle is advanced and stops when the aircraft passes over the finish line in the air for the third time. The flight score for mission three is shown in equation 7:

$$M3 = 6 * \left(\frac{Fastest_{Time\ flown}}{Team\ Time\ flown} \right) \quad (7)$$

Where Fastest time flown is the fastest time flown out of all competitors for three laps, and Team Time flown is the time that it took for our team to complete three laps.

Initial Parameters

In order to begin the design of the aircraft and sizing each component, guidelines must be determined from the product specifications and the conceptual design. The unmanned aircraft required for the competition will have several components to meet the requirements and to accomplish the designed missions. The aircraft will need a lifting device (wing), control surfaces, landing gear, propulsion, and mechanisms for the attachments of the internal and external stores (simulated missiles). The weight of the aircraft is the most critical part of the design, as it affects every part of the aircraft design, and is limited by competition rules to just 55lbs of weight with the inclusion of payloads. The aircraft will be launched on a fixed runway, so there are no human limitations to consider for this competition.

Product Specifications

Scoring Analysis

In order to translate the needs of the competition to product specifications, analysis was needed of the individual mission scoring process as well as and the total competition scoring.

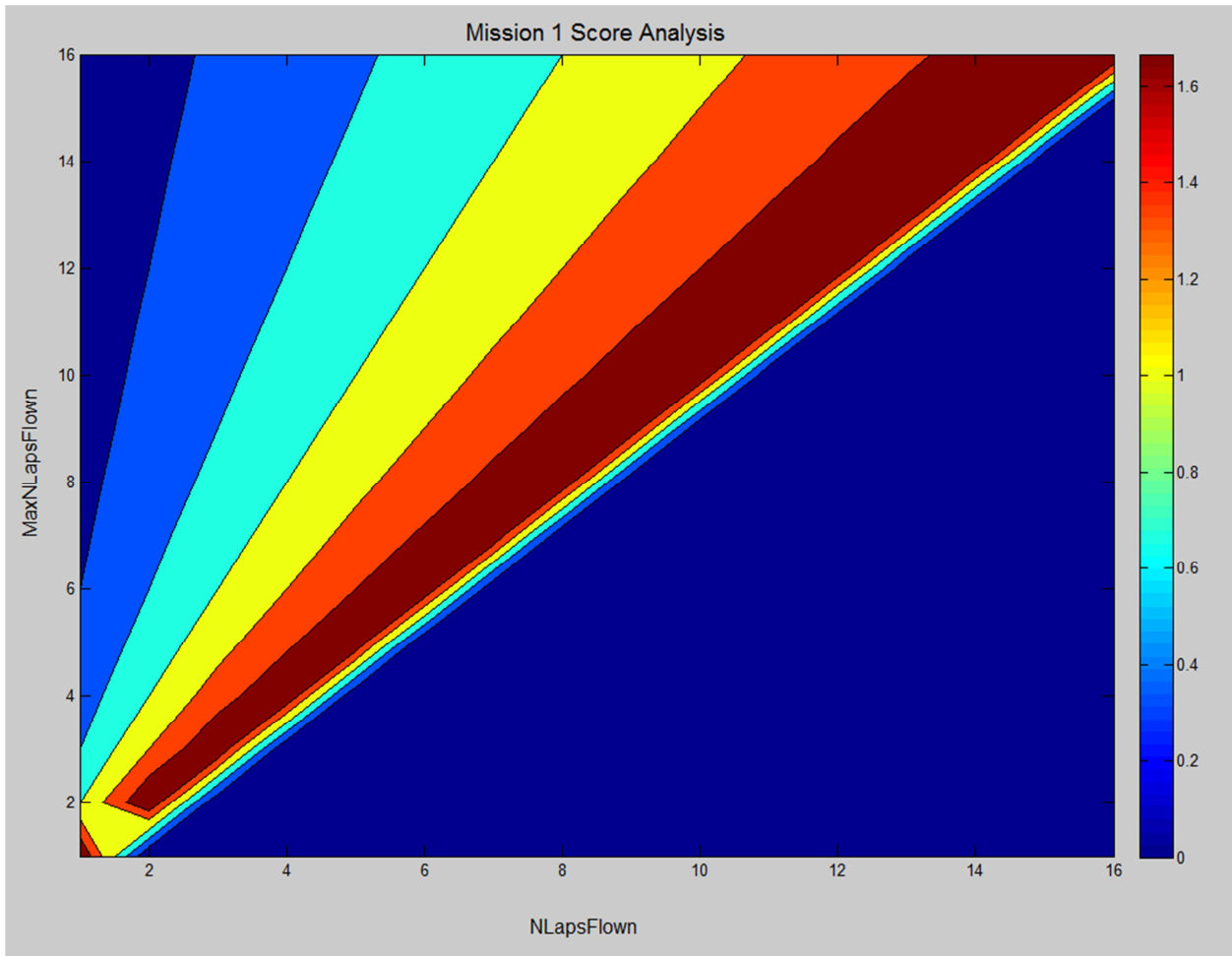

Figure 4 - Mission 1 Scoring Analysis

Figures four through six gives the scoring breakdown of missions one through three respectfully. For the first mission a high score is achieved by flying a high number of laps in the allotted time as compared to the rest of the field, if the team flies the highest number of laps out of all the teams then the score for that team will be maxed out at two points.

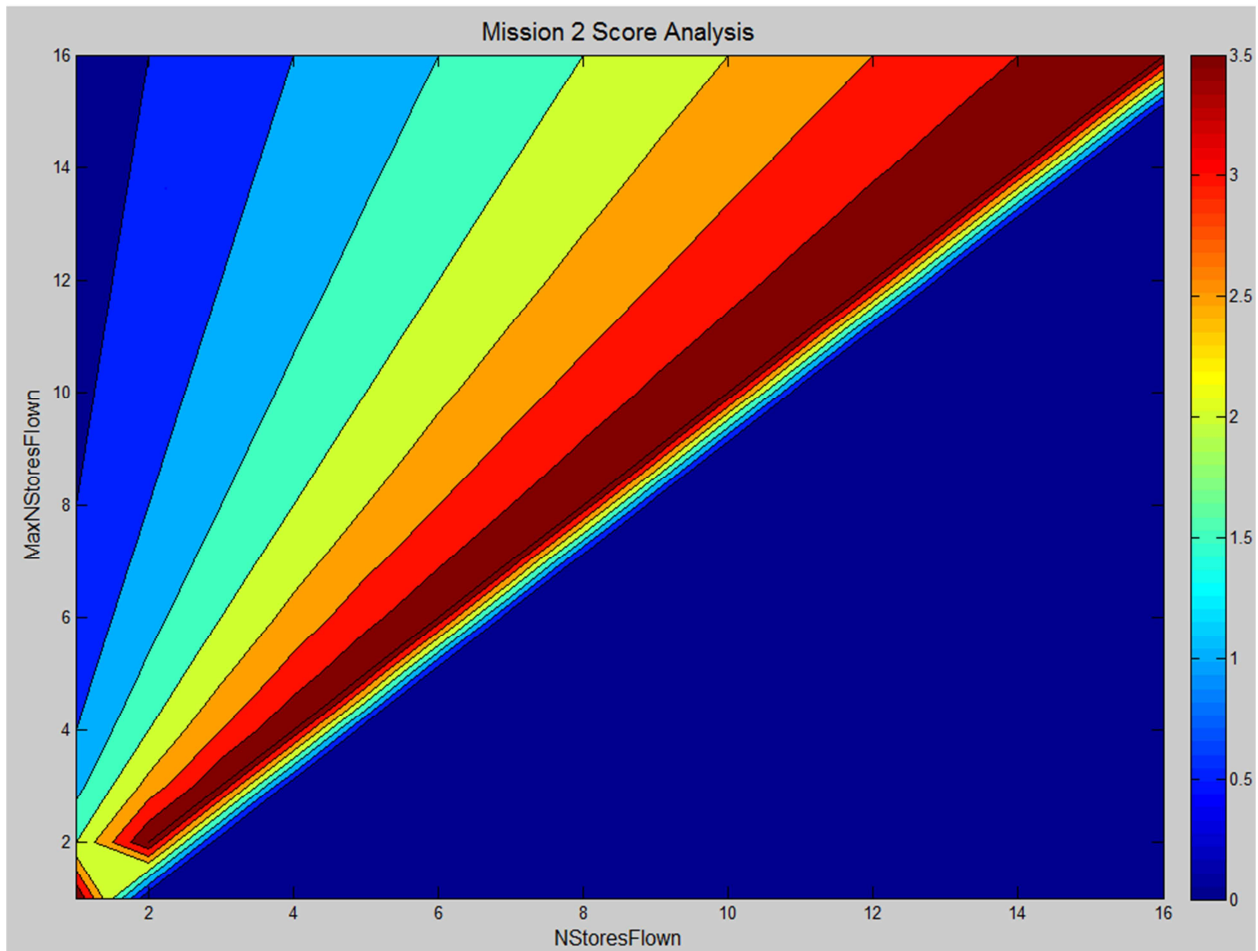

Figure 5 - Mission 2 Scoring Analysis

Mission two scoring analysis is similar to mission one except the number of internal stores is trying to be optimized in this mission. As the team carries a higher number of stores the score will increase and as that number approaches the number of the maximum number of stores flown by any team the score for that team will approach the maximum score of four points.

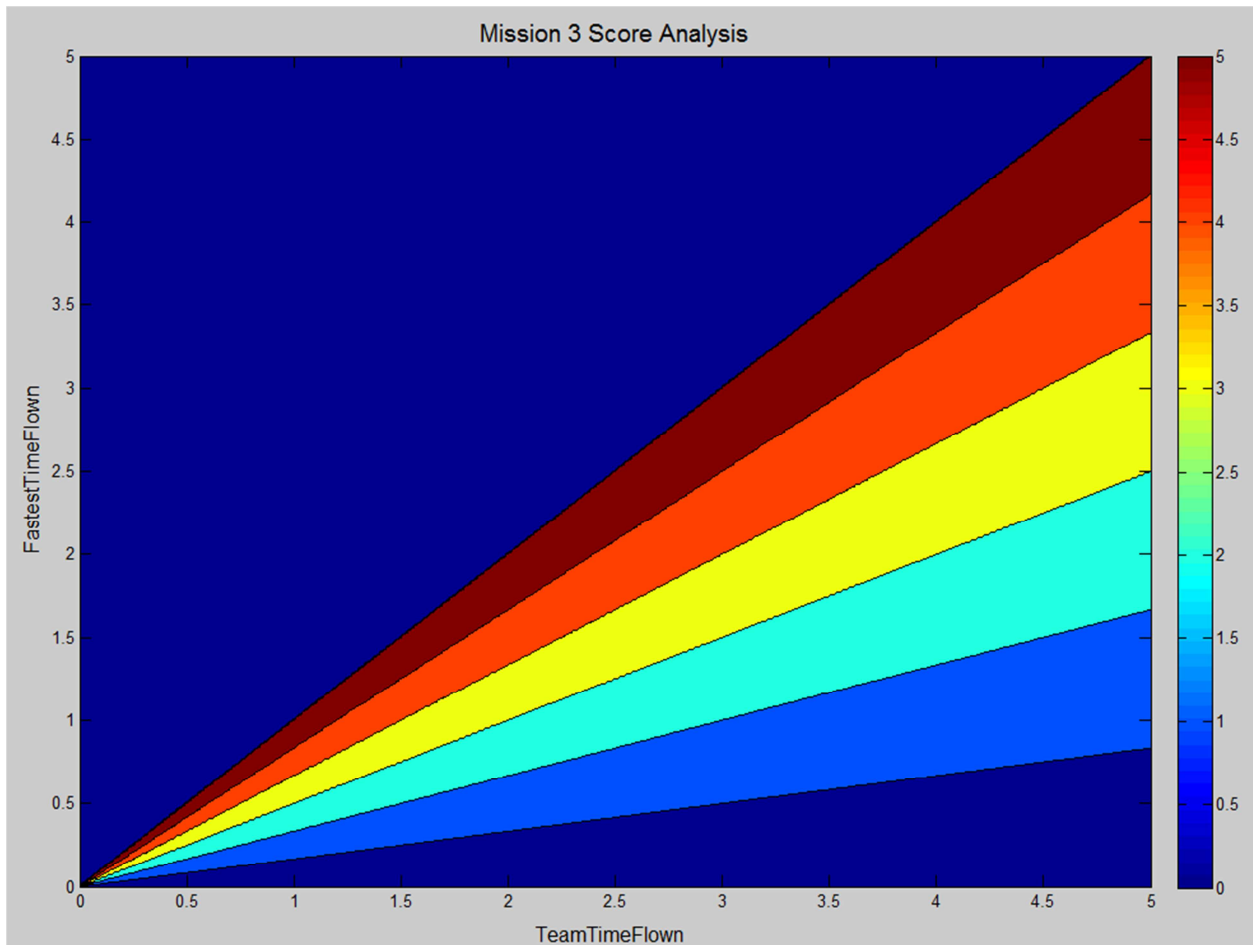

Figure 6 - Mission 3 Scoring Analysis

Mission three score depends upon the time it takes the team’s aircraft to fly three laps with the randomized payloads of internal and external stores. The objective is to get the lowest time flown out of all the teams. As the time of the team’s aircrafts time decreases and thus approaches the lowest time of all teams the team’s mission three flight score will approach the maximum of six points.

Figure 7 below gives the total score analysis for the competition which depends upon the total flight score times the written report score and the rated aircraft cost (RAC) which is dependent upon the empty weight and the size of the aircraft. It can be seen that the RAC has the highest impact on the total score; thus, it is important to have a low RAC, but the aircraft must be able to complete all missions successfully and it is because of this that the aircraft will be designed to meet all requirements but also have a low RAC.

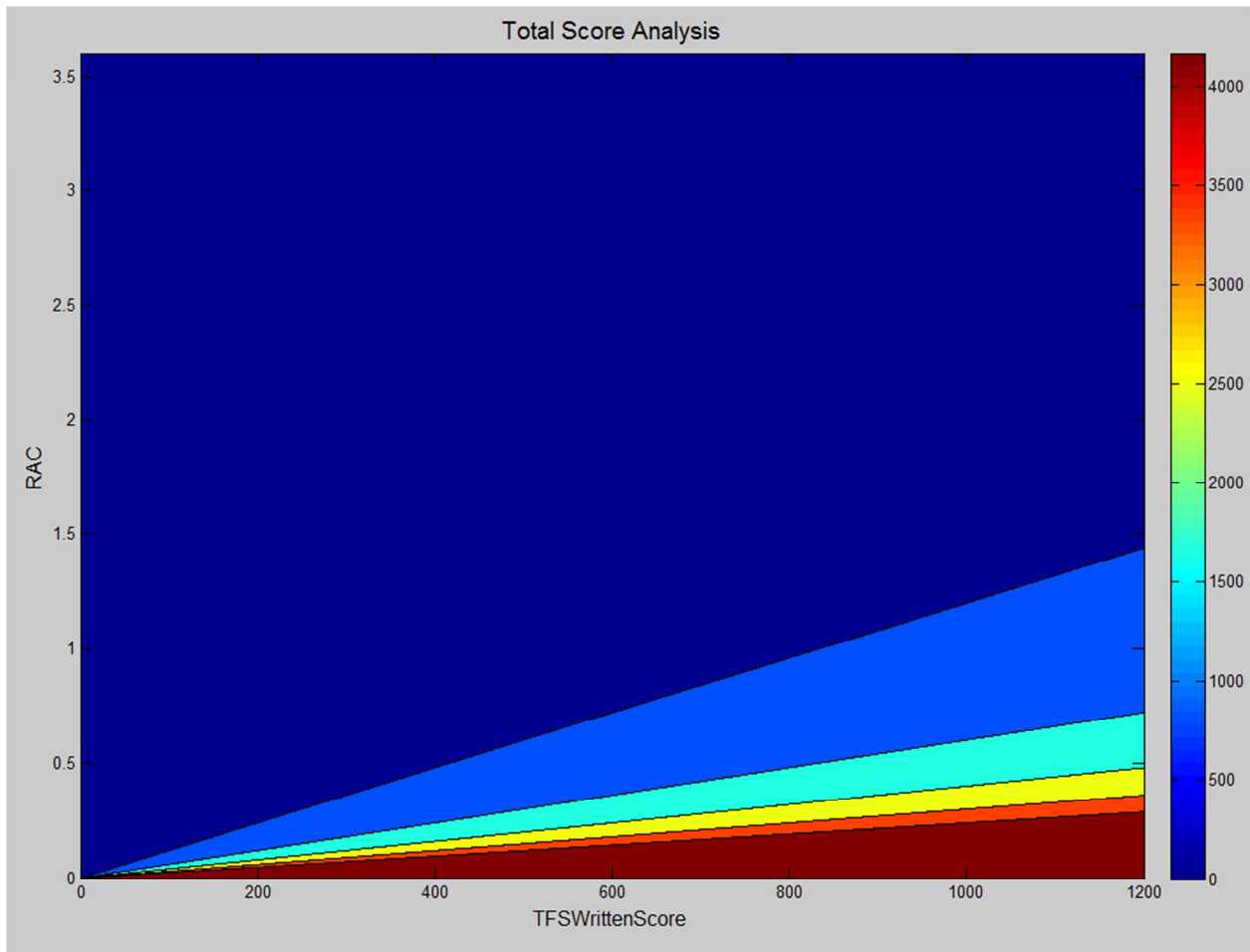

Figure 7 - Total Score Analysis

Table one below gives the product specifications for the aircraft that will be built to compete in this year’s competition. With a maximum payload weight of 3.25 pounds in mission three and an internal compartment capable of storing the internal stores for mission two, a maximum value for the empty weight was set at 3.75 pounds in order to still be able to take off in the prescribed distance and be able to compete with the other teams.

Table 1 -Product Specifications

Specification	Value
Empty Weight	< 3.75 lbs
Propulsion Battery Weight	< 1.5 lbs
Maximum Current Draw	20 amps
Number of Internal Stores	>= 4

Conceptual Design

Our concept generation was based upon figures of merit determined from mission objectives outlined in the competition rules and through extensive research on aerodynamics and the physical dynamics of radio-controlled model aircraft. The explanation of each is explained below.

Figures of Merit

- **Weight** - The weight of each component is very important and must be minimized.
- **Drag** - Drag opposes the thrust force generated by the motor which determines the amount of energy that must be drawn from the batteries. This is another very important figure that must be minimized.
- **Lift** - There must be sufficient lift to sustain flight with the maximum desired payload.
- **Stability** - The aircraft must carry out each required task reliably with very little performance fluctuation.
- **Maneuverability** - There must be effective control of the aircraft such that each mission can be performed with very little energy consumption or trouble.
- **Durability** - The aircraft must sustain light to moderate handling and the occasional rough landing.
- **Storage Capacity** - The payloads must securely store within the fuselage of the aircraft. It is required that the aircraft hold a maximum payload volume for a given design.
- **Complexity** - All required assembly must be completed with the available expertise.
- **Manufacturability** - All manufacturing must be completed with the available facilities
- **Cost** - All components must be made such that they may be replaced during prototype crashes.

Wing Configuration

The main wing must be able to accommodate external payloads, as well as the loads of the aircraft itself. Therefore, the main wing must be strong. It must also allow the aircraft to be aerodynamically efficient. The aspect ratio (wingspan to area of the wing platform) and airfoil are the key components when selecting a main wing.

The lifting device that we will implement will be required to develop sufficient lift of the aircraft in order to takeoff in the specified 30 foot square. The lifting device will also have to be limited on the induced drag that it produces such that it will be able perform the above stated task. The lifting device structure will also have to sustain loads on the scale of 2.5 g's in order to pass the preflight test, this will consist of a spar running the length of the lifting device's structure to guarantee that the lifting device can pass the above stated test performed by the competition judges. The material of the lifting device will have to be light enough to reduce weight but strong enough to provide a safe range in order to prevent sufficient damage if an accident does arise.

- **Delta Wing** - Triangular shaped single wing that broadens from tip to tail. Rigid structure and large carrying capacity are two major advantages. Most delta wing aircraft are used in supersonic applications.
- **Monoplane**-A highly conventional single wing which runs normal to the direction of flow across the fuselage.
- **Flying Wing**-Integrated body and wing type aircraft. If constructed ideally, it has very high aerodynamic efficiency. However, it is a difficult type of aircraft to stabilize and store internally, so it is simply wrong for this competition.
- **Canard**-Two smaller wings positioned forward on the aircraft which are intended to provide more lift and more control characteristics.
- **Biplane**-Two full-sized wings placed above one another for greatly increased lift. Greatly increased weight is a concern.

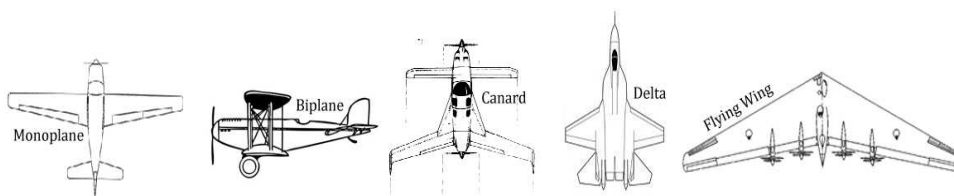

Figure 8: Wing Layout

Table 2: Wing Type Decision Matrix

FOM	Weight Value	Wing Types				
		Mono	Flying Wing	Delta Wing	Biplane	Carnard
Weight	0.2	4	1	4	1	3
Drag	0.2	4	3	1	2	2
Lift	0.3	3	4	3	5	4
Stability	0.15	4	5	3	5	3
Complexity	0.15	5	1	3	4	2
Total	1	3.85	2.9	2.8	3.45	2.95

Table 2 illustrates the most effective wing type for our aircraft design is the mono-wing type because of the simplicity in the design and the overall high score that it received in our decision matrix.

Fuselage Configuration

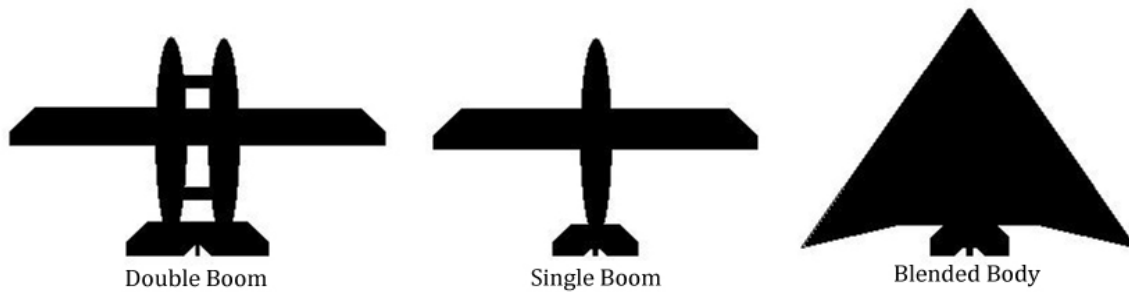

Figure 9: Fuselage Configurations

The fuselage contains its own subsystem set. They include a payload area, an electronics/control systems bay, and other possible servo areas. The payload area will be strictly dependent upon the minimum amount of payloads (4) that we must fit inside of the aircraft, while maintaining a low structural weight. The electronics bay is where the propulsion battery pack, motor (all battery packs must have a combined weight of no more than 1.5 pounds) and fuse should be located outside of the body of the aircraft.

Table 4: Fuselage Type Decision Matrix

FOM	Weight Value	Fuselage Types		
		Single Boom	Double Boom	Blended Body
Weight	0.4	3	1	4
Drag	0.2	4	2	5
Durability	0.1	4	3	5
Storage Capacity	0.3	4	5	1
Total	1	3.6	2.6	3.4

Table 4 demonstrates that the most effective fuselage type for this year’s competition is the single boom configuration because the design has relatively high storage capacity and durability while maintaining low drag as shown by the decision matrix.

Tail Configuration

The tail is largely responsible for climb rate and pitch control. Its selection is a function of balancing the lift and other moments generated by the rest of the aircraft. In a word, stability is the job of the tail. The tail needs to be rigid as to prevent any tail-induced instability of the aircraft in flight. Weight is not as important here because in comparison to the entire aircraft, the tail section is relatively light.

- **Conventional** – Rudder normal to wing, vertical stabilizer parallel to wing.
- **T-Tail** – Rudder normal to wing, vertical stabilizer above rudder
- **Twin Tail** – Dual Rudder, vertical stabilizer at bottom between rudders
- **V-Tail** – Rudder and vertical stabilizer blended into two V-configured rudders.

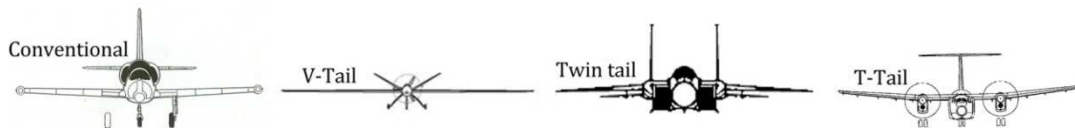

Figure 10: Tail Layouts

Table 5: Tail Type Decision Matrix

FOM	Weight Value	Tail Types			
		T-Tail	V-Tail	Twin Tail	Conventional
Weight	0.15	3	4	3	3
Drag	0.2	3	5	3	4
Stability	0.35	3	2	3	5
Control	0.2	4	2	4	5
Complexity	0.1	3	2	3	4
Total	1	3.2	2.9	3.2	4.4

Table 5 gives the decision matrix for selecting the best tail configuration given the constraints and requirements for this year’s competition, the conventional tail type exhibited high stability and control which are very important in the above described missions.

Engine Configuration

For the aircraft propeller layout, four propeller/motor configurations were examined.

- **Single Tractor** – A single propeller is placed in front of the fuselage. The motor is mounted behind the propeller and faces forward giving an appearance that the aircraft is "pulled" through the air.
- **Single pusher** – A single propeller is situated at the rear of the fuselage. Motor is mounted forward of the propeller facing the rear giving an appearance that the aircraft is "pushed" through the air.
- **Pusher-Puller** – This configuration uses two propellers. One pulling and the other pushing the aircraft through the air.
- **Ducted fan** – Propulsion configuration where a fan is mounted within a cylindrical duct.

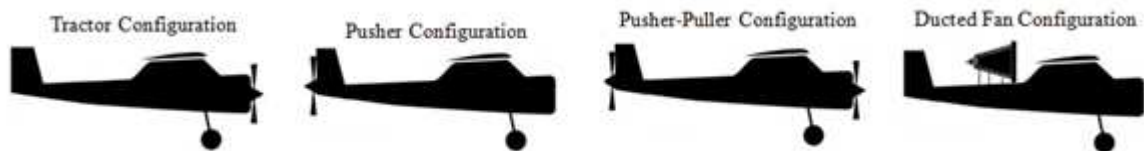

Figure 12: Propeller Layout

The most important FOMs to consider are weight/balance, efficiency, and complexity. Each of these is evaluated among several configurations in the following decision matrix:

Table 6: Engine Configuration Decision Matrix

FOM	Weight Value	Engine Configuration			
		Tractor	Pusher	Tractor-Pusher	Ducted Top-Mounted Tractor
Weight/Balance	0.4	5	4	5	2
Efficiency	0.4	4	4	3	3
Complexity	0.2	5	4	2	3
Total	1	4.6	4	3.6	2.6

Table 6 illustrates the decision matrix for selecting the most efficient engine configuration for the competition; the tractor was selected because of the well maintained weight and balance of the aircraft and the simplicity in the design as well as providing the propeller with clean air for high efficiency.

Landing Gear Configuration

For the landing platform, four designs were considered:

- **Single Wheel** – One wheel located at the center of gravity for the aircraft. This design is simple and lightweight; however, it may not be strong enough support the entire weight of the aircraft. It would also be very unstable when landing.
- **Bicycle** – Two wheels are centered along the longitudinal axis of the body. Distributes load through two shafts. The landing would be unstable.
- **Tricycle** – A single wheel is located toward the nose of the aircraft and two wheels are located toward the rear of the aircraft on the same rotational axis. This is a very stable design but it is relatively heavy and will induce more drag.
- **Tail Dragger** – Two wheels located toward the nose of the aircraft and a single wheel located toward the rear. The front wheels are on longer shafts which cause the nose to point upward and the tail to “drag”. This is a stable design but the majority of the load would be supported by the smaller tail wheel. This may cause durability issues.

The following matrix describes the design criteria for selecting the landing platform and the respective scores of each design.

Table 7: Landing Gear Decision Matrix

Figure of Merit	Weighting Factor	Single Wheel	Tricycle	Tail Dragger	Bicycle
Weight	0.30	4	3	3	2
Drag	0.10	4	4	3	3
Durability	0.15	2	5	4	4
Stability	0.10	1	5	3	3
Manufacturability	0.15	4	3	3	2
Efficiency	0.20	4	3	2	1
Total	1.00	3.40	3.60	2.95	2.30

As can be seen from the above decision matrix, the tricycle configuration was determined to be the optimal landing platform design. It has the best stability characteristics and is also very resilient to high impact landings.

Payload Configuration

External Payload – This will be a function of our wing manufacturing methods.

Internal Payload Configurations

The crux of this design is to optimize the plane around its missions. The performance on these missions is contingent upon how efficiently the internal and external stores are configured and arranged. The internal stores portion of the design is the first step in sizing the rest of the aircraft. Minimizing the space and weight required to fully house the stores is what will allow the aircraft to be optimized for size and weight, thus the fuselage is given a base volume to cover, the wings and propulsion system have a known weight to lift, the landing gear has a base weight to support upon landing.

Option 1

The competition lists stringent requirements for the internal storage method of our aircraft's mandatory stores. These constraints have been an evolving set of guidelines since the project began, and have eliminated a few of our best ideas. (The rules have been addressed already?) The design shown in the figure to the right shows one of our original applications, the model rockets

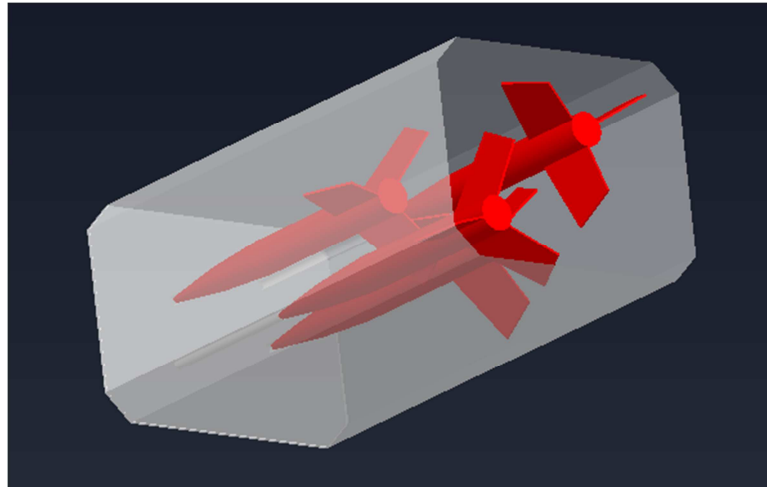

attach from the tip of the rocket's nose to the front of the payload housing and are in a configuration such that they could be dropped one at a time. However, this attachment method has been ruled out by the committee, as the updated rules state: no alterations can be made to the rocket aside from internal weight ballasting. To comply with this constraint we can simply move the mounting pins of the payload compartment up an amount equal to the radius of the rocket, and simply attach them around their cylindrical body with appropriate strapping.

The attachment method itself is fairly limited in design, making the actual orientation of the rockets a much more important consideration. The scoring of mission two is dependent on total amount of internal stores carried; however a failed flight mission will eliminate a team from competition completely. With this in mind, we have considered designing our plane around the minimum required internal stores possible (4). This configuration would, of course, put us at a disadvantage in mission two, although when taking the overall size/weight of the aircraft into consideration, it becomes increasingly important to manage the size of the fuselage appropriately.

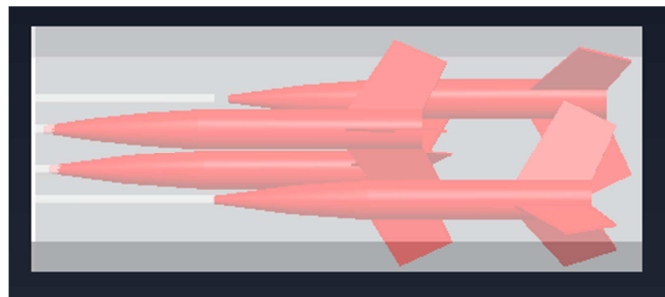

Option 2

For this method an individual bracket or mounting device would be used to hold each rocket. This mount would be attached to the upper surface of the fuselage and the store or payload would be strapped to the mount with the use of an elastic band in order to tension the rocket to the mount and restrict movement. From the diagrams depicting this design below, the rockets are on the same plane which allows for a shallower fuselage and lowered drag on the plane as a whole. The purpose of the mounting device is to restrict the rockets from contacting each other and placing the weight of the rocket at a favorable location relative to the weight of the aircraft in order as not to modify the location of the center of gravity too much. The dimensions of the box are 9.5 x 15.5 x 5.5 inches.

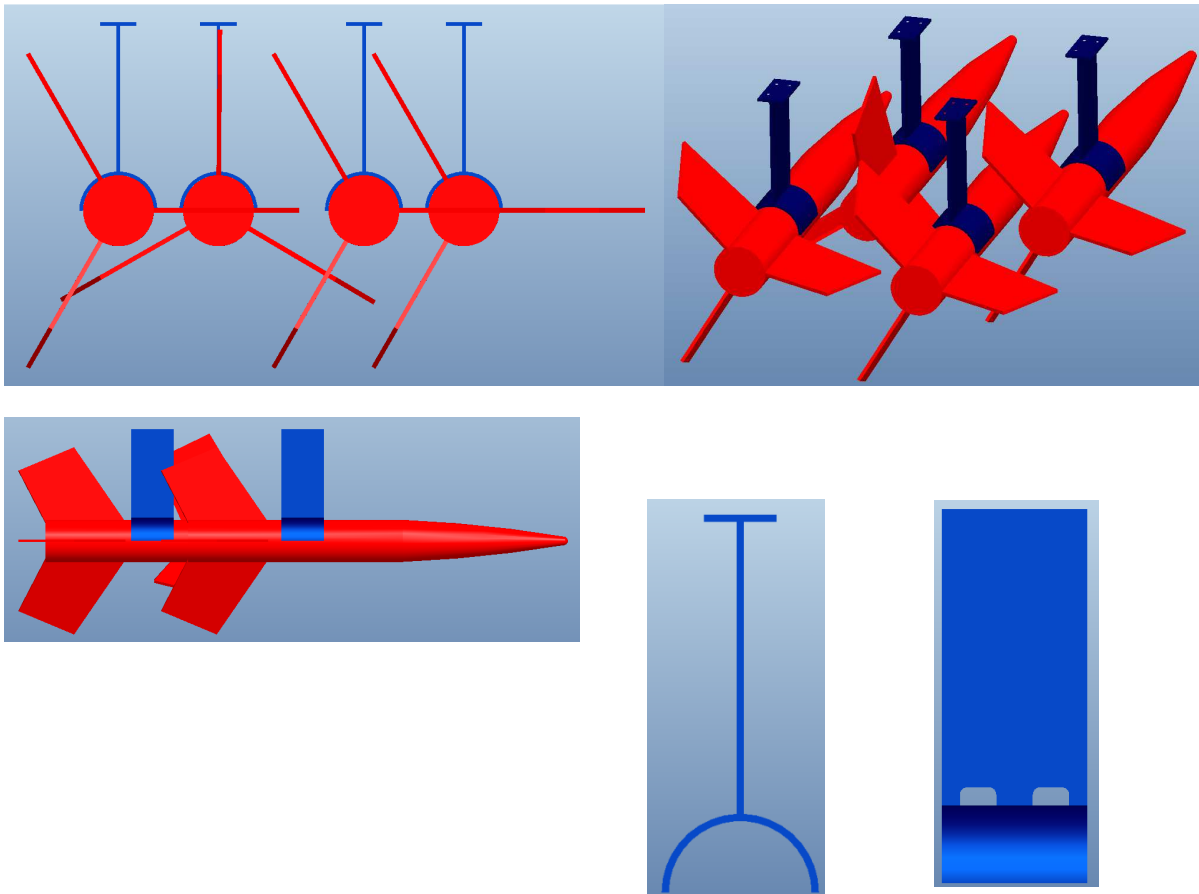

Option 3

This method of internal stores attachment is based on one principle. The idea is to minimize the box of space that is required inside the bay of the aircraft. Minimizing the volume will minimize the amount of material required to surround it, and in turn will minimize the weight and volume of the aircraft, increasing its performance and efficiency given a limited power supply.

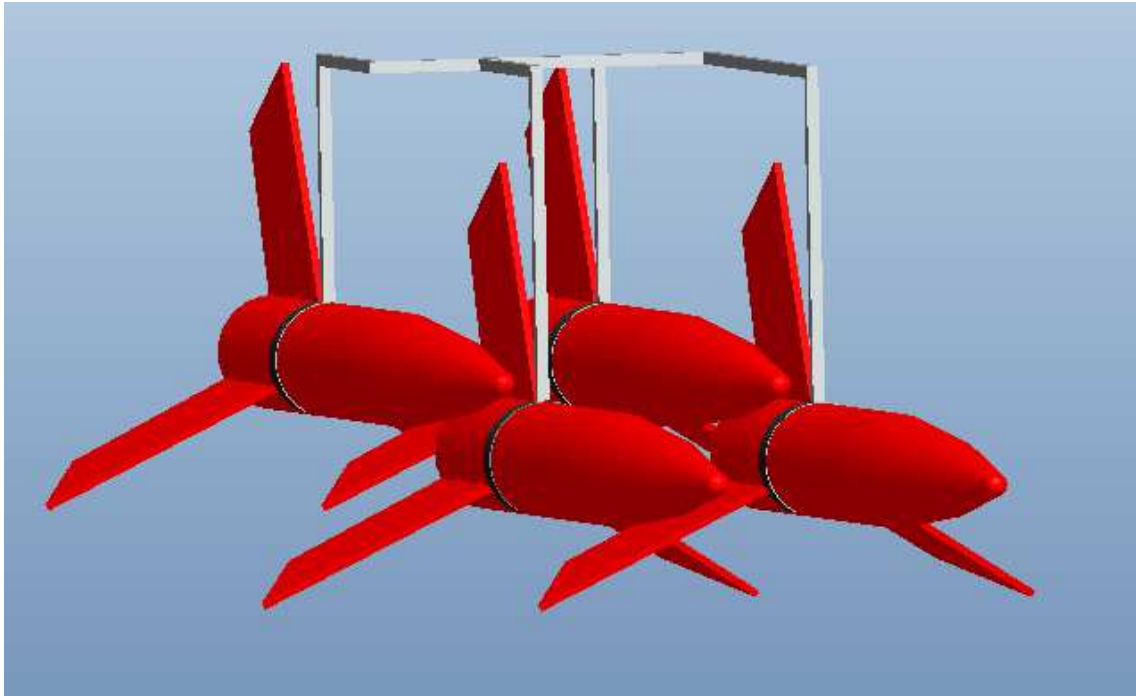

What was achieved here was to determine a configuration of stores that allows reasonable proximity between the rockets, while still allowing enough distance so that they cannot touch in flight. The volume required by this system is 4.57 inches high by 7.24 inches wide by 15.57 inches long. This means that the fuselage may be minimized along these parameters, and the box is only 515.16 in³ volume.

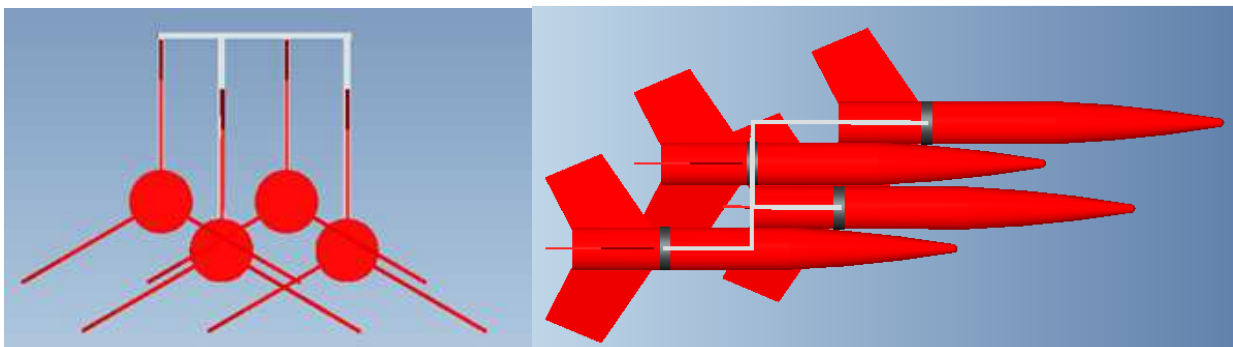

The metallic figure holding the rockets in place is essentially a cradle that suspends each store from the top, and will be thickened to reduce deflection due to in-flight forces. This will attach the stores to the aircraft, while preventing them from coming in contact with one another.

Wing Design

Airfoil Selection

The process for wing design began with analyzing airfoil sections and exploring the characteristics that would best fit this year's competition requirements. From advice from advising and time constraints, it was decided to implement a pre-existing airfoil design on this year's plane; thus, no radical new airfoil designs would be developed. Research provided a basis for choosing the fundamental airfoils to analyze. The airfoils were analyzed in a 2D panel method solver, XFOIL, where the drag polars (C_l vs. C_d), lift curves (C_l vs. α), and moment coefficients were compared for each respective airfoil.

As required in this year's competition rules; the short take off and high payload weights, the main wing should have high lift at low Reynolds numbers, low drag at cruising state and should also be relatively easy to manufacture. From estimates of the weight of the aircraft with payloads, an estimated speed range of the aircraft and the geometry of the aircraft a Reynolds number of 200,000 was chosen as the value at to compare airfoil characteristics at. Low drag while at a cruising state or at a low alpha is imperative to increasing the speed of the aircraft as well as reducing the overall drag, as there will be a massive amount of drag in the third mission carrying the external stores. This is also important as the maximum aerodynamic efficiency of an airfoil occurs when it is at its design lift coefficient and expected cruise velocities. An airfoil that is relatively easy to manufacture is important in simplifying the design and reducing the empty weight of the aircraft. In the following plots, six airfoils are compared and subsequently one is chosen for the main wing of the aircraft.

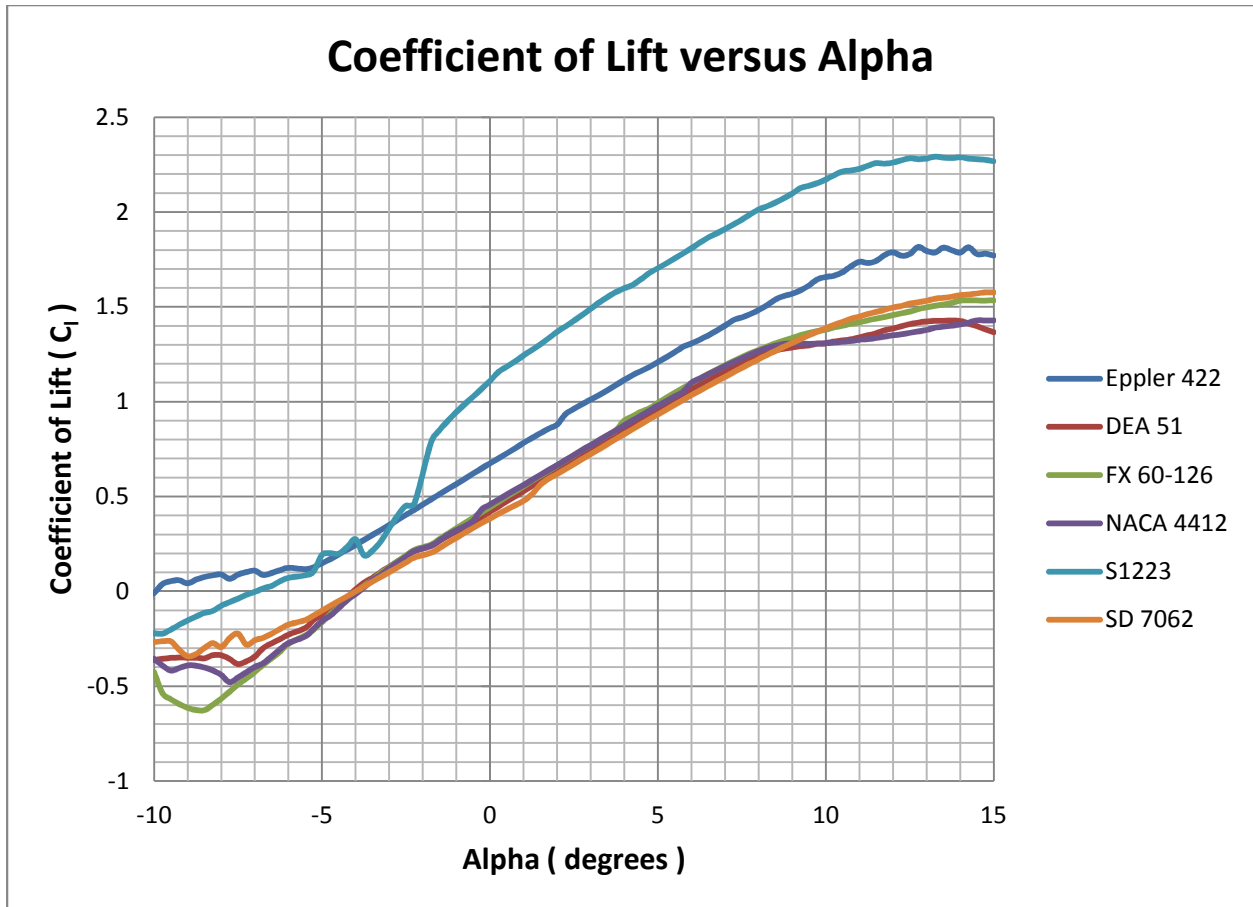

Figure 13 – Coefficient of Lift versus Alpha for airfoils under consideration for main wing.

All of the airfoils that were considered are high lift, and as shown in figure 13 all expect of two of the airfoils are grouped tightly together resembling the same characteristics in the coefficient of lift versus angle of attack. Above it can be seen that S1223 has a very high coefficient of lift compared to the others and Eppler 422 is above average while below S1223. From figure 13 alone Eppler 422 and S1223 are viable candidates for the main wing of the aircraft.

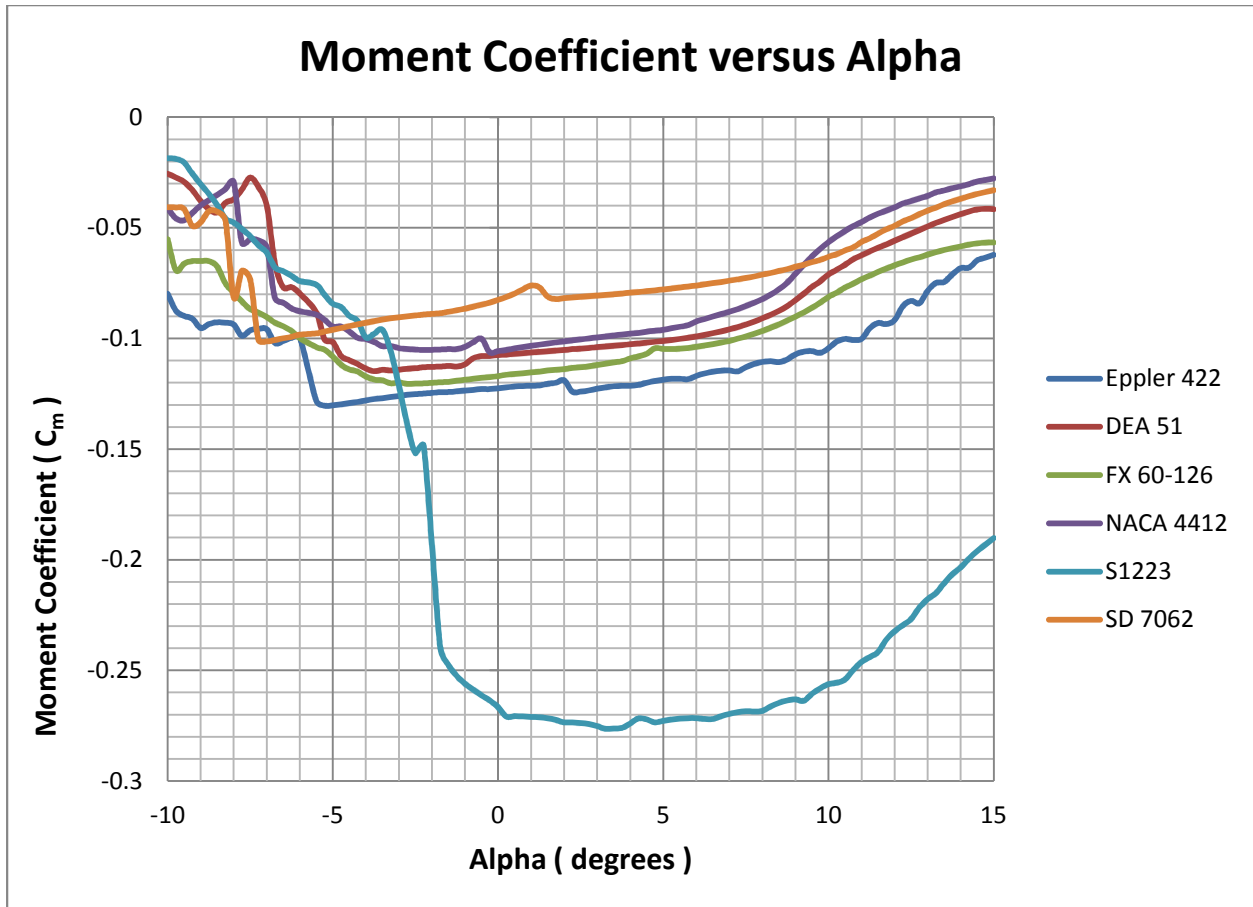

Figure 14 – Moment Coefficient versus Alpha for airfoils under consideration for main wing.

Shown in figure 14 are the moment coefficients of the airfoils under consideration versus angle of attack for each airfoil. A negative moment coefficient acts to pitch the aircraft in a nose down direction, a desirable moment coefficient is as close to zero as possible. The two airfoils that were the best performing in the coefficient of lift versus alpha are the two worst in this category; with S1223 being far worse than the Eppler 422 while the Eppler is grouped together with the other airfoils. This suggests that Eppler 422 is the optimal choice for the main wing of the aircraft.

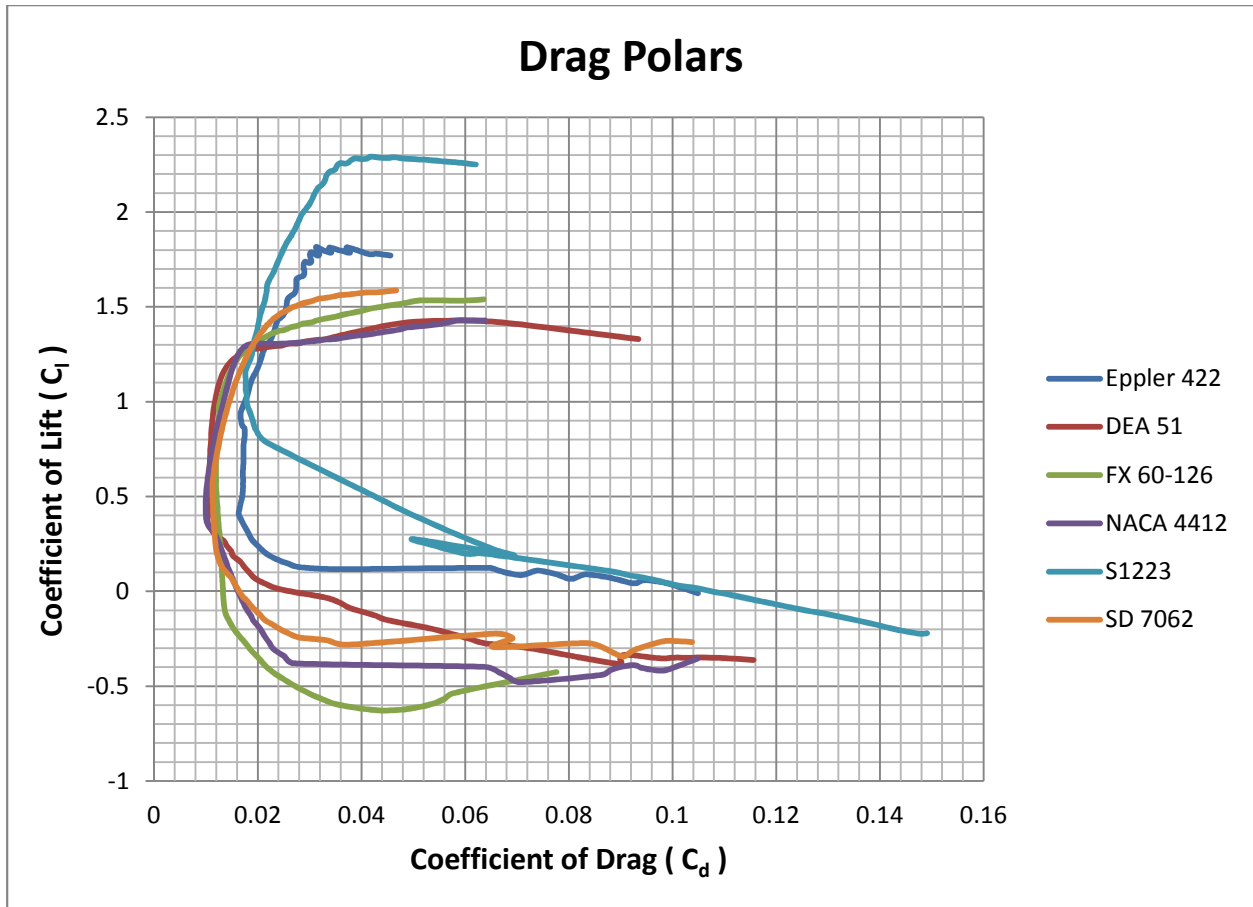

Figure 15 – Drag Polars for airfoils under consideration for main wing.

Figure 15 displays the drag polars for the airfoils tested and analyzed for use in the main wing of the aircraft that the team is designing. Drag polars show the relationship between the coefficient of lift and the coefficient of drag and is important in choosing an airfoil that will exhibit a low drag condition while the aircraft is in low angle situations such as cruise. The plot shows that the S1223 is less than satisfactory in this category as well while the Eppler 422 exhibits quantities that are suitable for the main wing when paired with the results of the other plots.

The chosen airfoil to be implemented on the main wing of the aircraft is the Eppler 422. The airfoil has a high maximum lift while producing a moment coefficient that can be balanced by the tail of the aircraft and a drag polar that will reduce the drag on the aircraft while in a cruising state. The aerodynamic characteristics of the Eppler 422 airfoil are displayed in Table 8 and the profile of the Eppler 422 airfoil is shown in figure 16.

Table 8 Eppler 442 air foil Characteristics

Max C_l	1.8159
Stall Angle (deg)	15
Max C_l/C_d	60.0429
C_l at Max C_l/C_d	1.2609
Angle at Max C_l/C_d (deg)	5.5

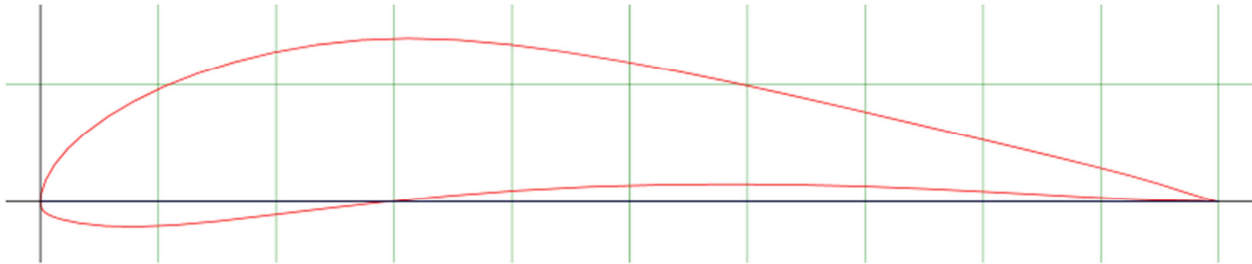

Figure 16 – Eppler 422 Profile

Wing Geometry

In order to perform an initial sizing of the main wing of the aircraft the total weight as estimated in the product specifications section and a wing loading value to fit the desired flight characteristics of the aircraft. From this initial value of the wing area, span and chord an iterative process was used to determine if the sizing was adequate for the estimated minimum stall speed of the aircraft, this process was repeated until suitable dimensions were reached. Basic fundamental aerodynamic equations were used throughout the sizing process. With an assumed loaded weight of seven pounds from the heaviest loading condition in mission three which would consist of five rockets in total and a wing loading value of 20 ounces per foot squared. Equation 8 shown below used these values to determine the required wing area for the estimated weight.

$$S = \frac{\text{Weight}_{\text{Aircraft}}}{\text{WingLoading}} \quad (8)$$

After the wing area was determined the aspect ratio was chosen in the range of 6 to 8 as is standard in almost all aircrafts that have the desired characteristics that we seek. The span of the wing or the length of the wing was determined from equation 9 shown below.

$$b = \sqrt{\text{AR} * S} \quad (9)$$

The chord length was then calculated using equation 10 shown below using the wing area and the wing span determined above.

$$c = \frac{S}{b} \quad (10)$$

The required velocity of the aircraft was then calculated using equation 11 shown below using a required lift force of 31.138 Newtons, the wing area determined above, the max coefficient of lift of the selected airfoil above, and the density of air at standard pressure.

$$V = \sqrt{\frac{2L}{\rho S C_l}} \quad (11)$$

From the above equations the wing sizing and characteristics are shown in table 9 below.

Table 9 - Wing Sizing and Characteristics

Wing Area (S)	806.4 in ²
Span (b)	77.77 in
Chord (c)	10.37 in
Aspect Ratio (AR)	7.5
Minimum Takeoff Speed	21.387 mph

Tail Design

Airfoil Selection

The main purpose of the tail section is to provide the aircraft a means of control with respect to the yaw and roll of the aircraft. It is also necessary to design the tail to provide stability and trim to the aircraft in all flying conditions. Similar to the procedure in the main wing design the tail section design will consist of an airfoil selection and the geometry of the tail section with respect to the size, weight and geometry of the aircraft as a whole. Through research it was found that a symmetric airfoil for the vertical section and the horizontal section will provide adequate stability for the cruise conditions of the aircraft. The horizontal section is usually oriented at a small incidence angle to offset the pitching moment caused by the main wing. Many symmetric airfoils have similar characteristics so a select number of airfoils were analyzed for the tail section; the airfoils that were analyzed are commonly used on aircraft and RC planes. The selection criteria was that the airfoil produce minimal drag while being able to still control the aircraft and have an adequate size for ease of fabrication. For this analysis the drag polars were examined to find the ideal candidate.

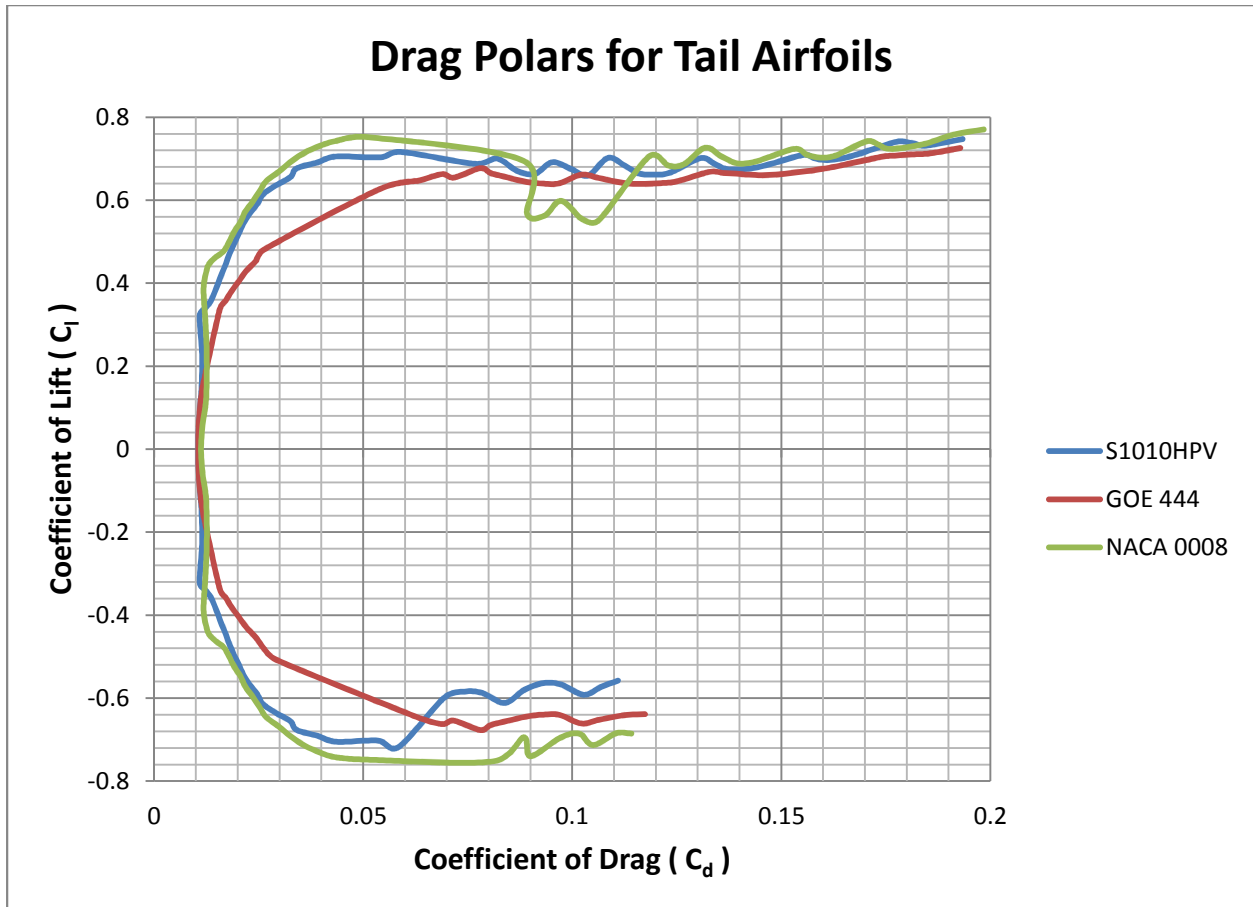

Figure 17 - Drag Polars for airfoils under consideration for the tail section

As shown in figure 17 the drag polars for the analyzed airfoils are very similar in nature, but NACA 0008 was chosen because of the slight reduction in drag at higher coefficients of lift and the slightly higher percentage of thickness relative to the chord will result in an easier manufacturing of that airfoil. Figure 18 below gives an outline of the NACA 0008 airfoil.

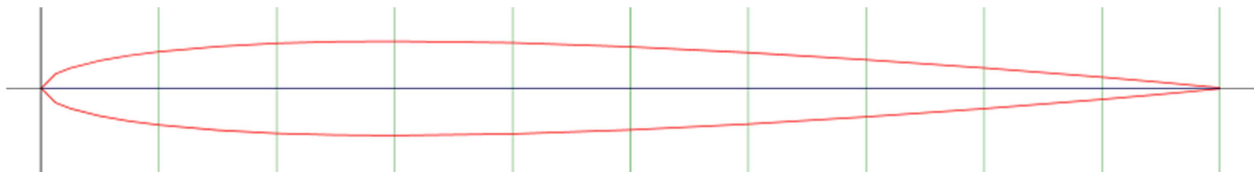

Figure 18 - NACA 0008 airfoil profile

Tail Geometry

The sizing of the tail section was used from calculation form Raymer. The tail areas for the vertical and horizontal tail were calculated with equations 13 and 14 respectfully.

$$S_{VT} = \frac{c_{VT} \cdot b_w \cdot S_w}{L_{VT}} \quad (12)$$

$$S_{HT} = \frac{c_{HT} \cdot \bar{C}_W \cdot S_W}{L_{HT}} \quad (13)$$

Where c_{xT} is the tail volume coefficient, b_W is the wingspan, C_W is the wing mean chord, S_W is the wing area, and L_{XT} is the effective moment arm. The tail volume coefficients were estimated through research from existing data on tails of aircrafts similar to the proportions of ours and were found to be 0.04 and 0.7 for the vertical and horizontal stabilizers respectively. The geometry of the tail section is given in table 10 below. According to Raymer, the tail aspect ratio shows little variation through a wide range of aircrafts and may therefore be determined based on historical data. For aircrafts with similar proportions to this one, the desired tail aspect ratios are between 3 and 5 for the horizontal stabilizer, and between 1.3 and 2 for the vertical stabilizer.

Table 10 - Tail Section Dimensions

Vertical Span	10.239 inches
Vertical Chord	7.9 inches
Horizontal Span	23.76 inches
Horizontal Chord	7.9 inches
Moment Arm	31.107 inches

Control Surface Design

The control surfaces which consist of the rudder on the vertical stabilizer, the elevator on the horizontal stabilizer and the ailerons on the main wing are used in the control, stability and the maneuverability of the aircraft while in flight. According to Raymer the ailerons, rudder, and elevator should be at least approximately 20 percent of the chord of the airfoil that the control surface is a part of. Similarly the span of the control surface should be at least 40 percent of the span of the airfoil that the respective control surface is on. Table 11 below gives the minimum dimensions of the control surface for our aircraft.

Table 11 - Control Surface Minimum Dimensions

Elevator Span	>9.5 inches
Elevator Chord	>1.575 inches
Rudder Span	>4.1 inches
Rudder Chord	>1.575 inches
Aileron Span	>31.108 inches
Aileron Chord	>2.075 inches

Propulsion System

The propulsion system for this aircraft must be capable of lifting seven pounds into the air within the allotted runway space. It must be considered that the short take-off will be done in Tuscon, Az, where the altitude is approximately 2500 ft. The combinations considered were optimized first for static thrust, and then again for effect on RAC. The analysis was done by considering an array of possible motors, propellers, and batteries. The procedure was to analyze numerous combinations of each of these, until trends were found, and parameters could be optimized. Due to constraints in programming, these combinations were analyzed one by one. The following graph shows the general relationship between our two most restrictive parameters. The propulsion system must pull no more than 20 amperes, and must generate at least 40 ounces of force in order to successfully take off in the runway area, given a specific size estimate for the aircraft and given the lifting capabilities of the wing which has been optimized for lift in this short-take-off competition.

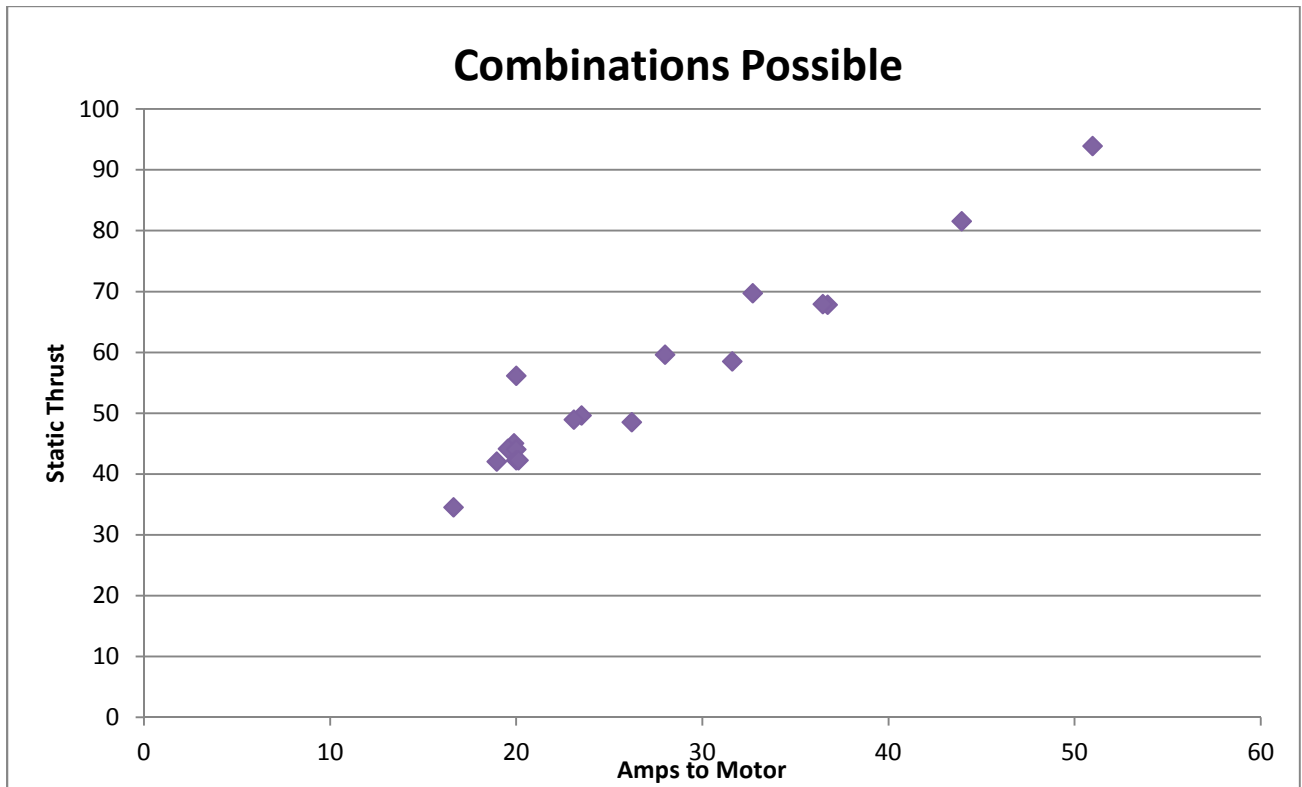

The figure above shows a representation of the tested array of combinations. Some of which are capable of successfully completing a take-off within the confines of the competition rules.

Once a consistent relationship was found between amperage input and thrust output, the graph was truncated to show all combinations that were suited to generate the thrust necessary to successfully lift the aircraft within the given space. The points on the graph below represent the combinations of propellers, motors, and batteries which are capable of providing at least 40 ounces of thrust, while drawing no more than 20 amps of current.

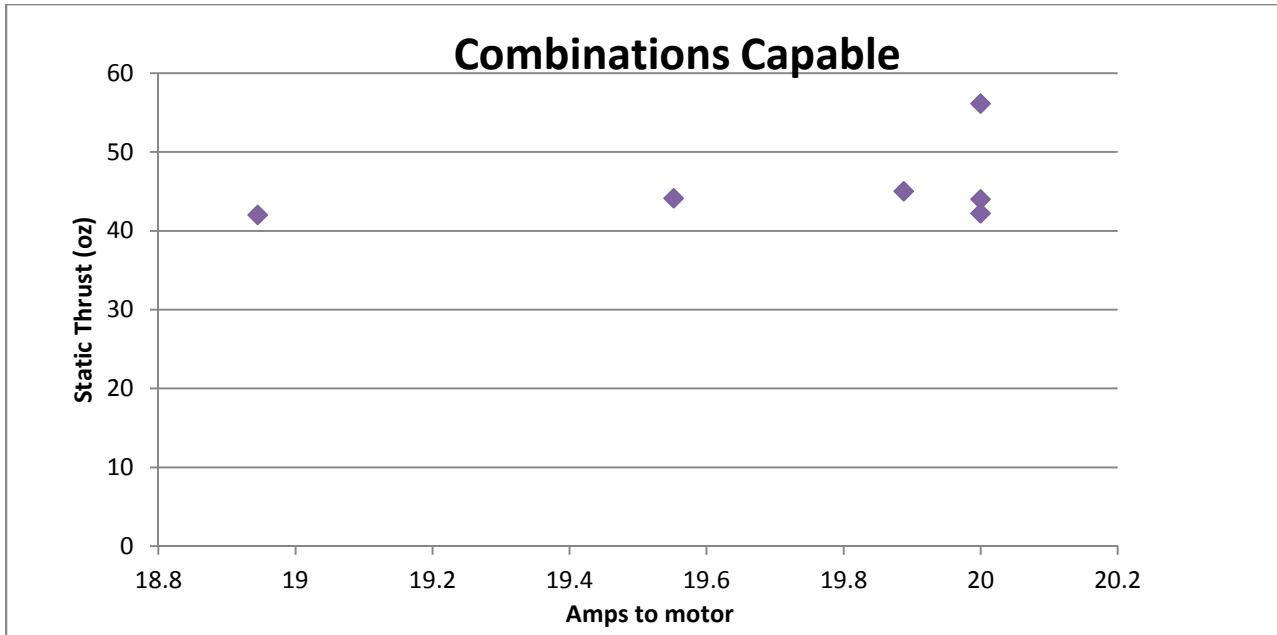

The figure above is a truncated version of the previous chart. This shows only the combinations that would successfully lift the plane within the rules of the competition.

Motor Selection



Neu 1905-1.5Y/1350



Scorpion S 3020-14

These two motor selections are capable of providing the required thrust to the aircraft, but both need a specific motor controller in order to not draw more than 20 amperes. The current progress on this front is the selection and ordering process.

Propeller Selection

Because different propellers may be used for each of the three missions, it is important to find the optimal propeller for each mission. The propellers to order were selected based upon the thrust that they could efficiently provide on particular motor options. The propellers have been considered for their advance ratio, pitch, diameter, weight, and rigidity. Propellers of varying dimensions have been selected, and will each be tested experimentally in order to determine which combinations provide the best combinations of thrust and energy efficiency. The propellers considered are all APC electric models between 6 and 8 inches in diameter.

Electronics and Controls

Accurate communication between the pilot, the aircraft, and its respective components, is paramount to a team's success in the AIAA Design/Build/Fly competition. The aircraft's electronics system is composed of two subsystems: controls and propulsions. The control system includes the servo battery pack, receiver, and four control surface servos. The propulsions system includes the propulsions battery pack, electronic speed controller (ESC), and motor. Both the controls and propulsions systems must employ a separate battery pack, to power each on a separate circuit as per the competition rules. Total circuit amperage also cannot exceed 20 amps, which will be governed by the simple addition of a 20 A blade fuse in-line with the propulsion circuit.



Transmitter and Receiver

For the pilot-to-aircraft communications, our team has selected a Hitec Aurora 9 transmitter because of its low latency response time, as well as the associated Hitec receiver, the Optima 7. This combination provides simple flight programming without the need of a separate microcontroller, enabling our team to set the competition required all channel "failsafe mode" without the complicated coding usually associated with servo movement. An estimated wiring layout is provided in the figure below to illustrate how these components will respectively connect.

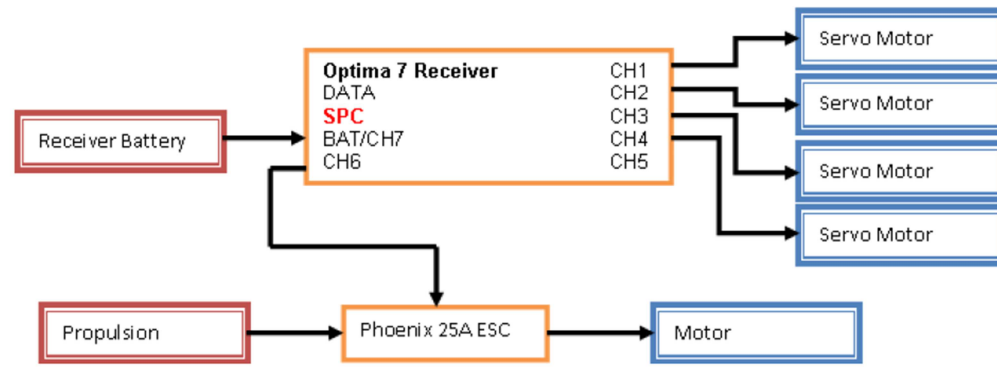

Servos

The control surfaces (ailerons/rudder) of the aircraft are each manipulated by their own servo, which will be electrically connected through the Optima 7 receiver as per the previous diagram. We have chosen the HiTec HS325 micro servo based on its straightforward compatibility as well as its weight to torque ratio. The servo weighs 0.09 lbs and is powered at 6 volts which renders a torque value of 0.25 ft lbs.



Batteries

The competition rules dictate specific battery guidelines that each team must follow in order to compete. Given a choice between Nickel Cadmium (NiCd) or Nickel Metal Hydride (NiMH) type cells, we have selected NiMH batteries in order to avoid the memory effect associated with NiCd battery packs. This memory effect requires the NiCd pack to be fully discharged before recharging, which may not be possible given the nature of the competition. The NiMH cells have a higher energy density in comparison to NiCd as well, which is significant due to the maximum weight limit (1.5 lb) imposed on the propulsion system's power pack.

Controls Battery Pack

To power the receiver/servos that enable aircraft's flight maneuverability we have chosen the ProTek R/C 5-Cell, 6.0V, 1600mAh NiMH Intellect Flat stick style Receiver Pack. The pack is small and lightweight (0.27 lb) and provides the maximum power into the Optima 7 receiver's range of 4.8-6 volts.



Motor Controller

This is responsible for ensuring that the motor does not draw more amperage than is permitted by the rules. It is also responsible for regulating the amount of power used by the motor, as decided by the operator. The primary focus in choosing an ESC is that the rated amperage is greater than the highest amperage pull ever used by the motor. In this case, a 25 amp ESC will suffice.

Structures/Materials

Materials Selection

The primary goal in materials selection is to minimize cost and meet all product specification goals that are outlined. For optimal performance, it has been decided to select materials that have a high Young's modulus (E), while maintaining relatively low weight properties (m). In order to properly select such a material, these two properties (mass and Young's modulus) must be compared and proper equations need to be derived. Once the equation is derived, the material properties must be isolated and inverted to determine the modulus (E). This may now be applied in the Young's modulus-Density diagram shown in Figure 19. From this, we are able to properly determine which materials are best suited for the aircraft structure.

$$\text{Root} \quad m = \rho V; \quad V = LA_0; \quad \sigma_f = \frac{P}{A}; \quad A_0 = \frac{P}{\sigma_f}$$

$$\text{Solving:} \quad m = \rho V; \quad m = \frac{\rho LP}{\sigma_f} = \left(\frac{\rho}{\sigma_f}\right) LP$$

$$\therefore \boxed{E = \frac{\sigma_f}{\rho}}$$

Where ' ρ ' is the density of the material. Also in this case, ' σ_f ' is the fracture stress of the material. Now we may analyze Figure 19 further.

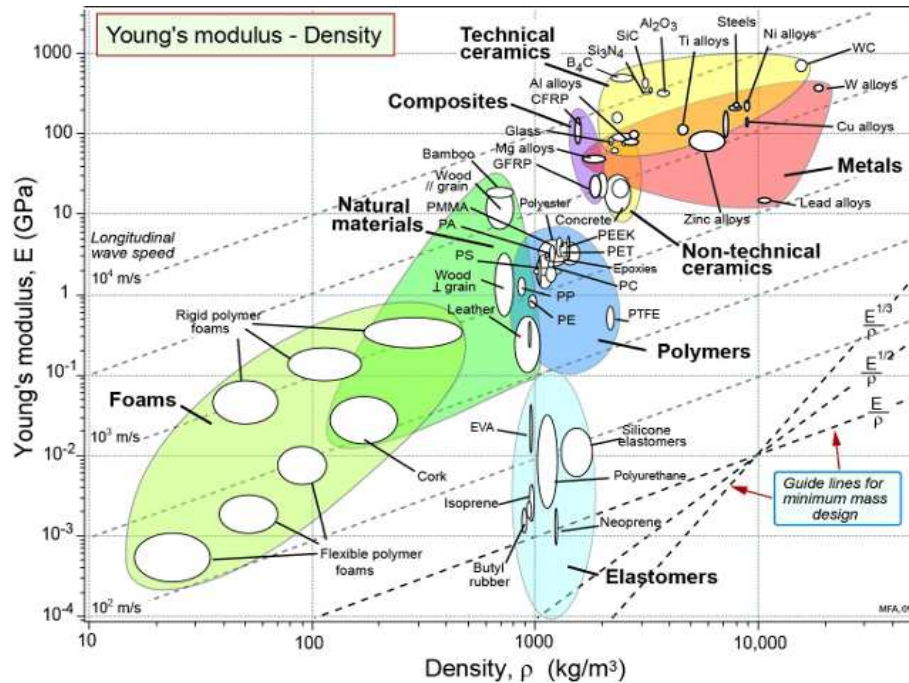

Figure 19 – Young’s modulus – Density diagram

The Young’s modulus defines the slope of the lines of interest, illustrated by the dotted lines in the diagram. These results show that the technical ceramics and composite materials are the optimal choice to complete the job. A great composite material that is readily available in the High Performance Materials Institute (HPMI) is carbon fiber, and this asset will indeed be utilized. Contrarily, we know that ceramic materials are susceptible to brittle failure. As a result, ceramics must be ruled out of any possibility in the design. The next best results shown are for wood and other natural materials. Balsa wood is a primary choice for its strength and low weight. Metals are not considered due to weight constraints. With these primary materials selected, the next job is to choose the proper methods of implementing them within the structure and perform a stress analysis on the potential materials for the wing under “worst case” conditions.

Materials Optimization

The efficient implementation of each material will result in a much lighter, must stronger structure than would otherwise be achievable. For example, the yield strength of carbon fiber is much greater in tension than compression. As a result, carbon fiber should be placed under tension whenever possible. Wood is far stronger when loaded in the longitudinal direction than transverse. Therefore, wood will only be loaded in the longitudinal direction.

References

Raymer, Daniel P. *Aircraft Design: A Conceptual Approach*. Virginia: American Institute of Aeronautics and Astronautics, 2006. Print.

Airfoil Comparison. *XFOIL*. Web. 07 Nov. 2012 <<http://airfoiltools.com/compare/index>>

Anderson, John. *Fundamentals of Aerodynamics*. Fifth. New York, NY: McGraw-Hill, 2011. Print.

Personal Aircraft Drag Reduction. Bruce Carmichael, page 195, Propeller behind tail - pros and cons.

Aircraft Design: A Conceptual Approach. Daniel P. Raymer. AIAA Education Series.

<http://www.aeroflight.co.uk/aircraft/types/dornier-do-335.htm>

<http://pitbullrotorcraft.com/links/gyrolink.html>

<http://loke.as.arizona.edu/~ckulesa/propulsion.html>

“ATMOSPHERIC FLIGHT: AERODYNAMIC LIFT”. *NASAQuest*, NASA, 9 February 2012. (accessed September 29, 2012).

<<http://quest.nasa.gov/aero/planetary/atmospheric/aerodynamiclift.html>>.

C., Niculiță, A. Bencze, and I. Câdea. "AIRCRAFT WINGS: PRESENT AND FUTURE". *Bulletin Of The Transilvania University Of Brasov, Series I: Engineering Sciences* 1, no. 50: 41-46. 2008. *Academic Search Complete*, EBSCOhost (accessed September 27, 2012).

Ewans, J.R. “AERODYNAMICS OF THE DELTA”. Accessed from the Flight Global Archive, 11 August 1951. pg. 172-174 (accessed September 28, 2012).

<<http://www.flightglobal.com/pdfarchive/view/1951/1951%20-%201545.html>>

Kermode, A.C. FLIGHT WITHOUT FORMULAE. 5th ed. updated by Bill Gunston. *Longman Group UK Limited*, 1989. Print.

Arunkumar, K.N, N. Lohith, and B.B Ganesh. "Effect of Ribs and Stringer Spacings on the Weight of Aircraft Structure for Aluminum Material." *Effect of Ribs and Stringer Spacings on the*

Weight of Aircraft Structure for Aluminum Material.N.p., n.d. Web. 30 Sept. 2012.
<<http://scialert.net/fulltext/?doi=jas.2012.1006.1012>>.

http://www.centennialofflight.gov/essay/Dictionary/Propeller_Design/DI62.htm

<http://www.grc.nasa.gov/WWW/K-12/airplane/propeller.html>

<http://www.allstar.fiu.edu/aero/flight63.htm>

http://jmcintyre.wikispaces.com/TDJ3M_Material_Selection

Appendix

All Dimensions are in inches

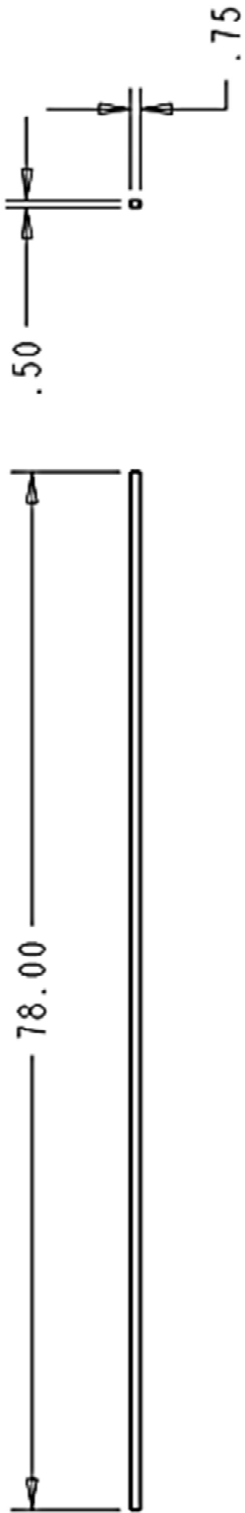

PROJECT	PART NAME		
Design Build Fly	Main Spar		
NAME	DATE	REV	
Team 16	Dec. 11, 2012	0	
DRAWING NUMBER	SIZE	SCALE	SHEET
	A	0.08	

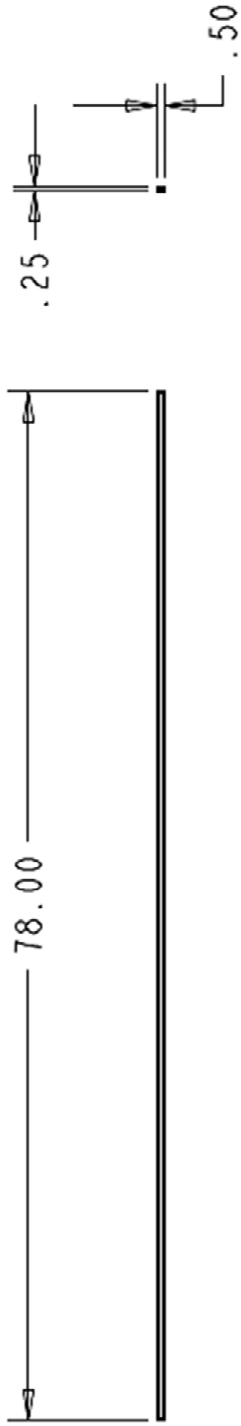

PROJECT		PART NAME	
Design Build Fly		Secondary Spar	
NAME	DATE	REV	
Team 16	Dec. 11, 2012	0	
DRAWING NUMBER		SIZE	SCALE
		A	0.08
			SHEET

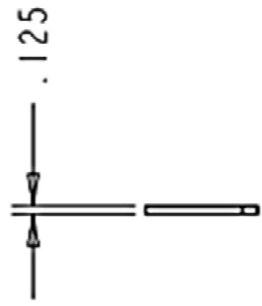
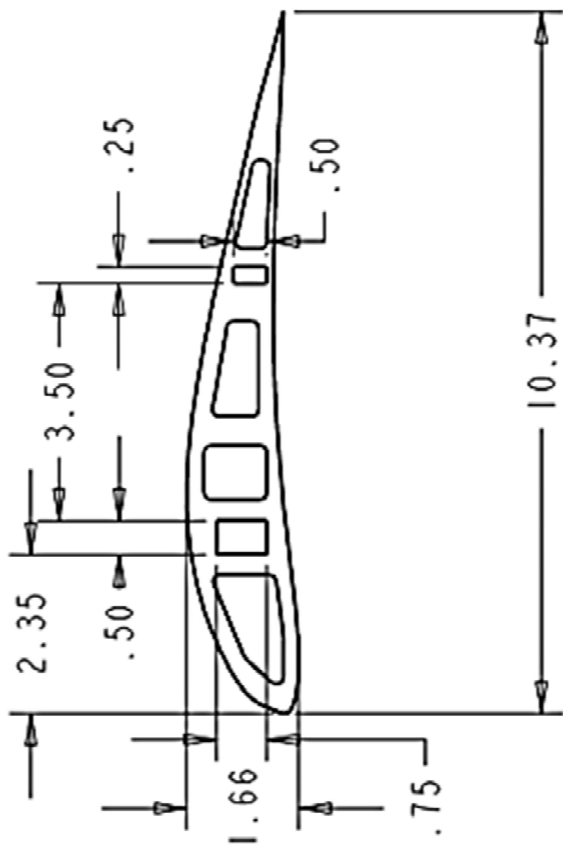

27 Required

PROJECT	PART NAME		
Design Build Fly	Main Rib		
NAME	DATE	REV	
Team 16	Dec. 11, 2012	0	
DRAWING NUMBER	SIZE	SCALE	SHEET
	A	0.04	

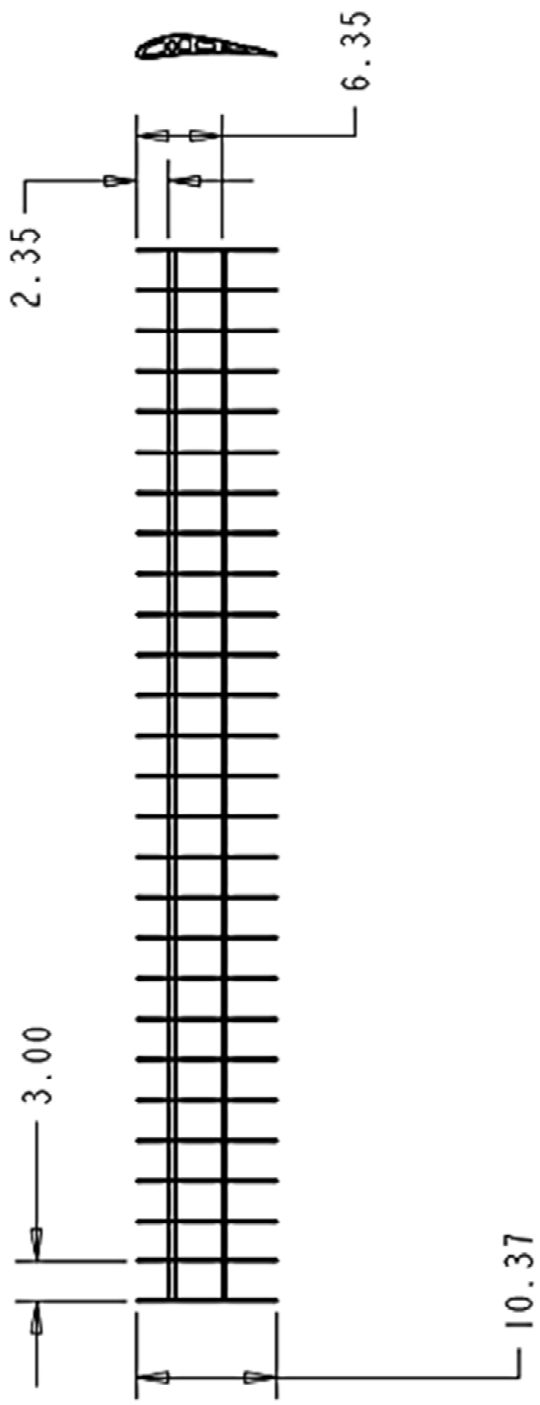

PROJECT		PART NAME	
Design Build Fly		Main Wing	
NAME	DATE	REV	
Team 16	Dec. 11, 2012	0	
DRAWING NUMBER		SIZE	SCALE
		A	0.08
			SHEET

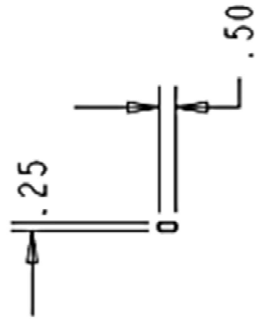
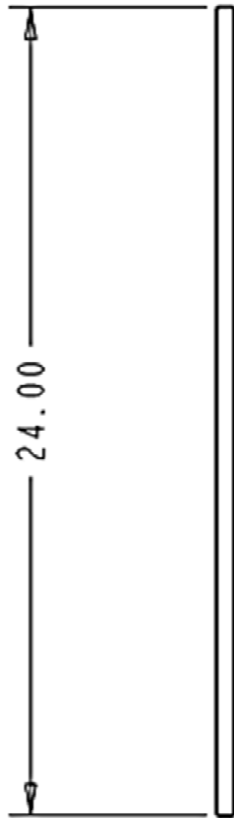

PROJECT	PARTY NAME		
Design Build Fly	Horizontal Tail Spar		
NAME	DATE	REV	
Team 16	Dec. 11, 2012	0	
DRAWING NUMBER	SIZE	SCALE	SHEET
	A	0.2	

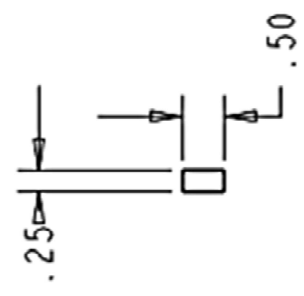
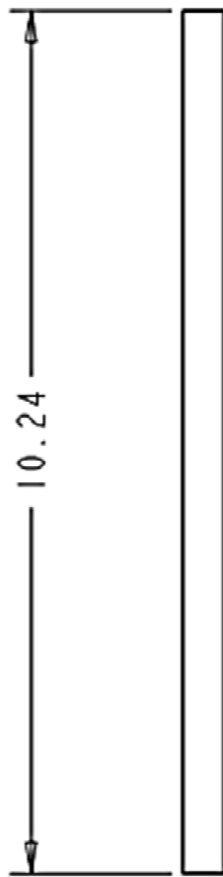

PROJECT		PART NAME	
Design Build Fly		Vertical Tail Spar	
NAME	DATE	REV	
Team 16	Dec. 11, 2012	0	
DRAWING NUMBER		SIZE	SCALE
		A	0.5
		SHEET	

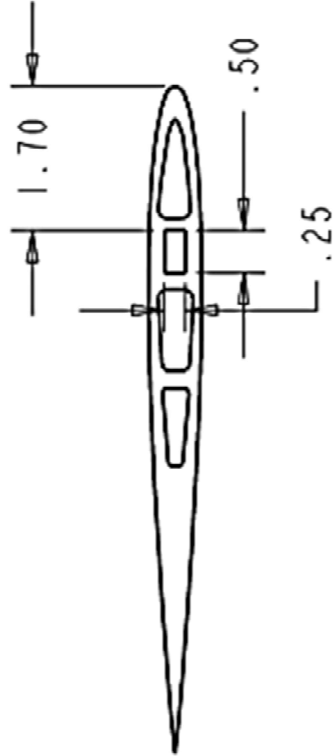
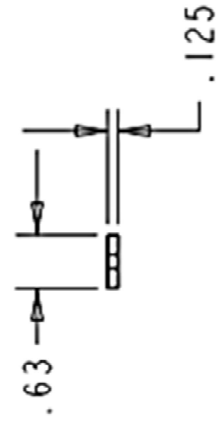
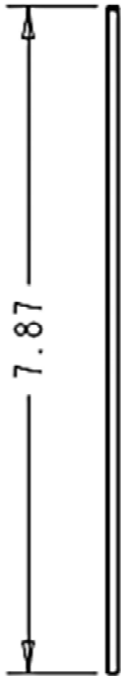

PROJECT	PART NAME		
Design Build Fly	Tail Rib		
NAME	DATE	REV	
Team 16	Dec. 11, 2012	0	
DRAWING NUMBER	SIZE	SCALE	SHEET
	A	0.5	

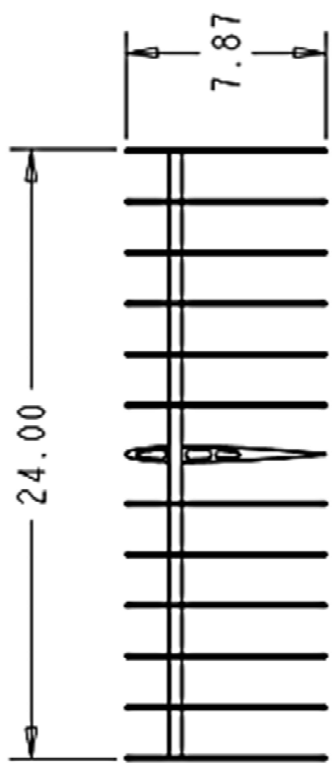
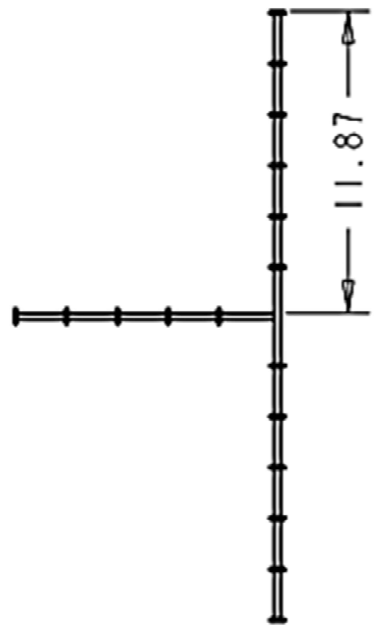
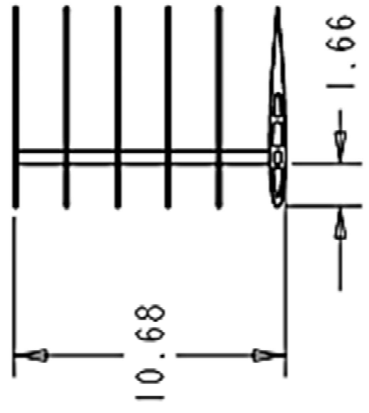

PROJECT	PART NAME	
Design Build Fly	Tail Assembled	
NAME	DATE	REV
Team 16	Dec. 11, 2012	0
DRAWING NUMBER	SIZE	SCALE SHEET
	A	0.15

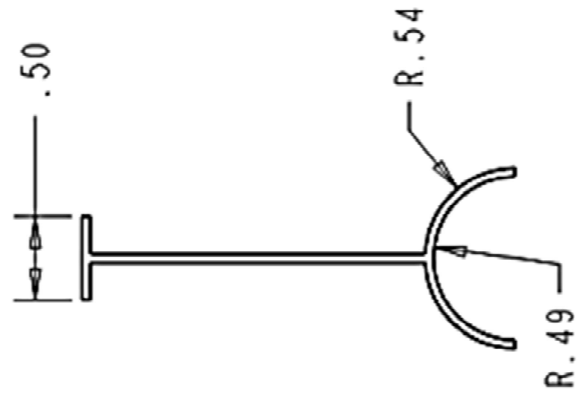
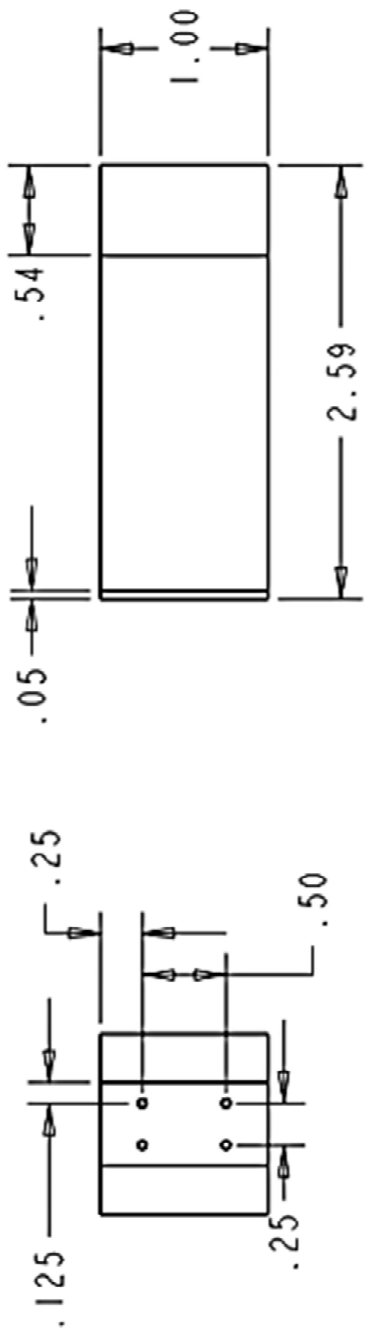

PROJECT	PART NAME		
Design Build Fly	Option 2 Bracket		
NAME	DATE	REV	
Team 16	Dec. 11, 2012	0	
DRAWING NUMBER	SIZE	SCALE	SHEET
	A	1.0	

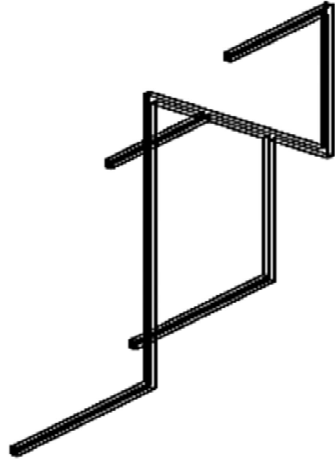
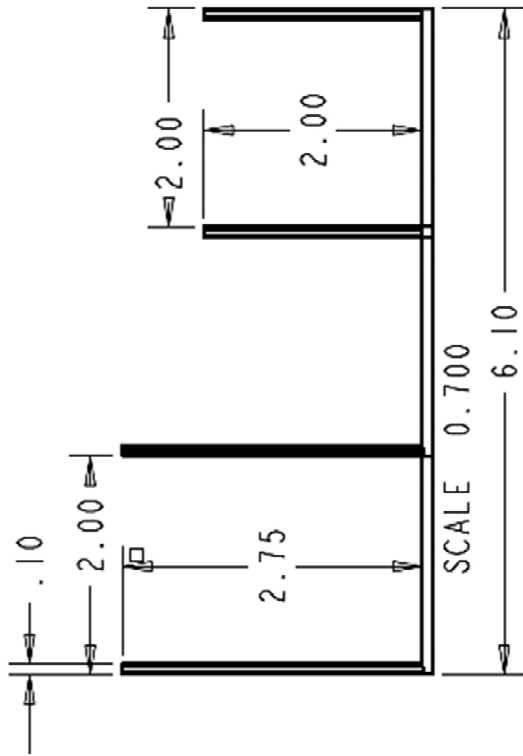

SCALE 0.500

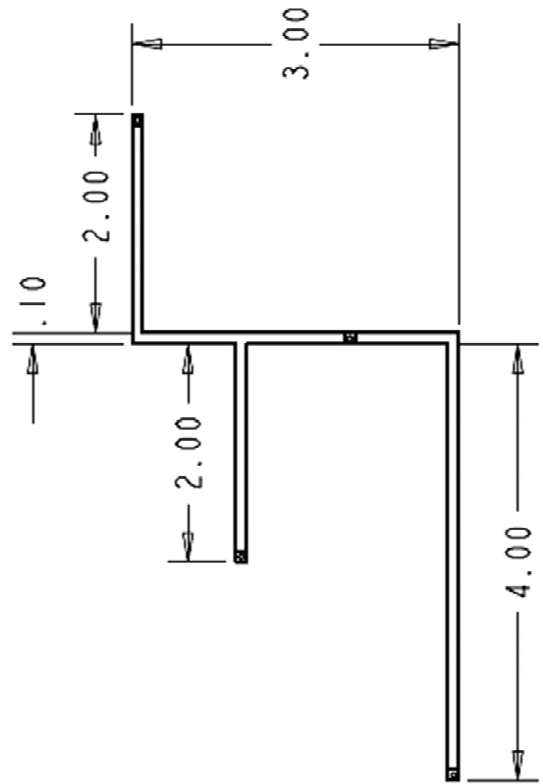

PROJECT	PART NAME		REV
Design Build Fly	Option 3		0
NAME	DATE	REV	
Team 16	Dec. 11, 2012	0	
DRAWING NUMBER	SIZE	SCALE	SHEET
	A		

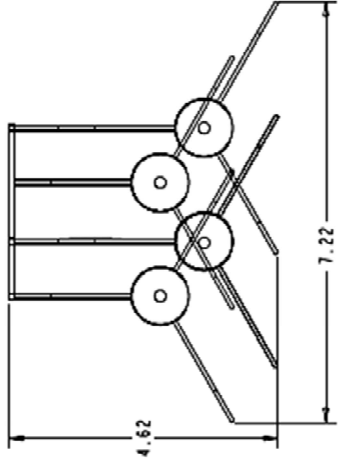
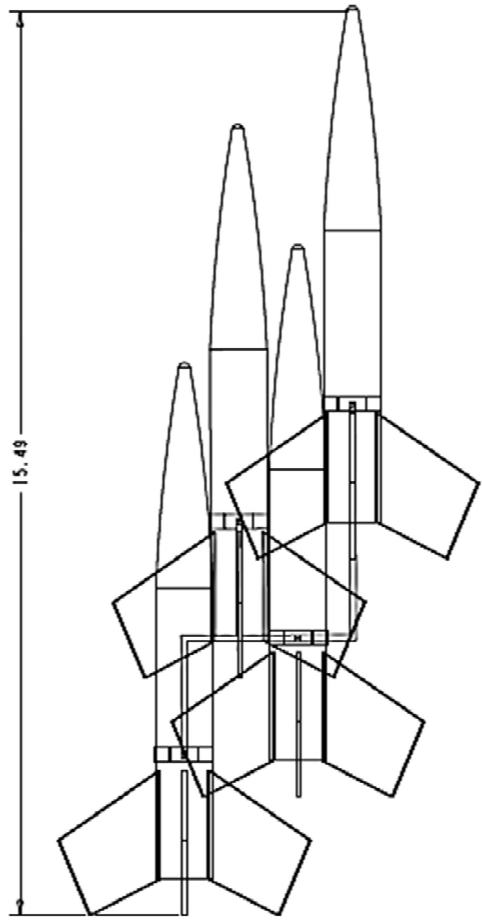
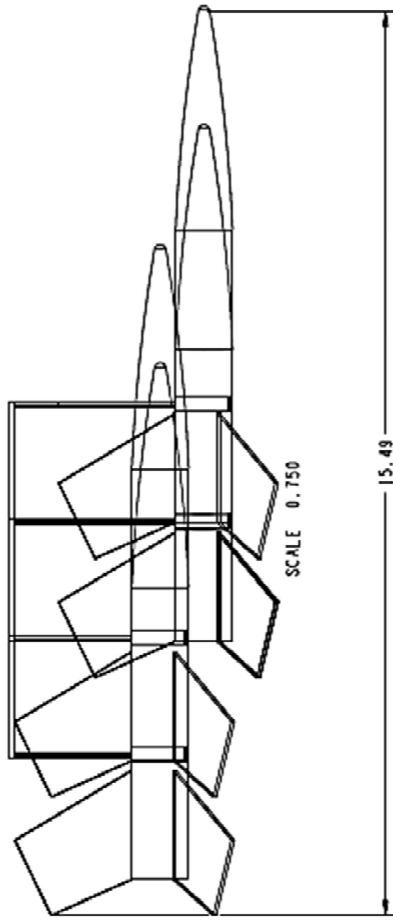

PROJECT	PART NAME		
Design Build Fly	Option 3 Assembly		
NAME	DATE	REV	
Team 16	Dec. 11, 2012	0	
DRAWING NUMBER	SIZE	SCALE	SHEET
	A		

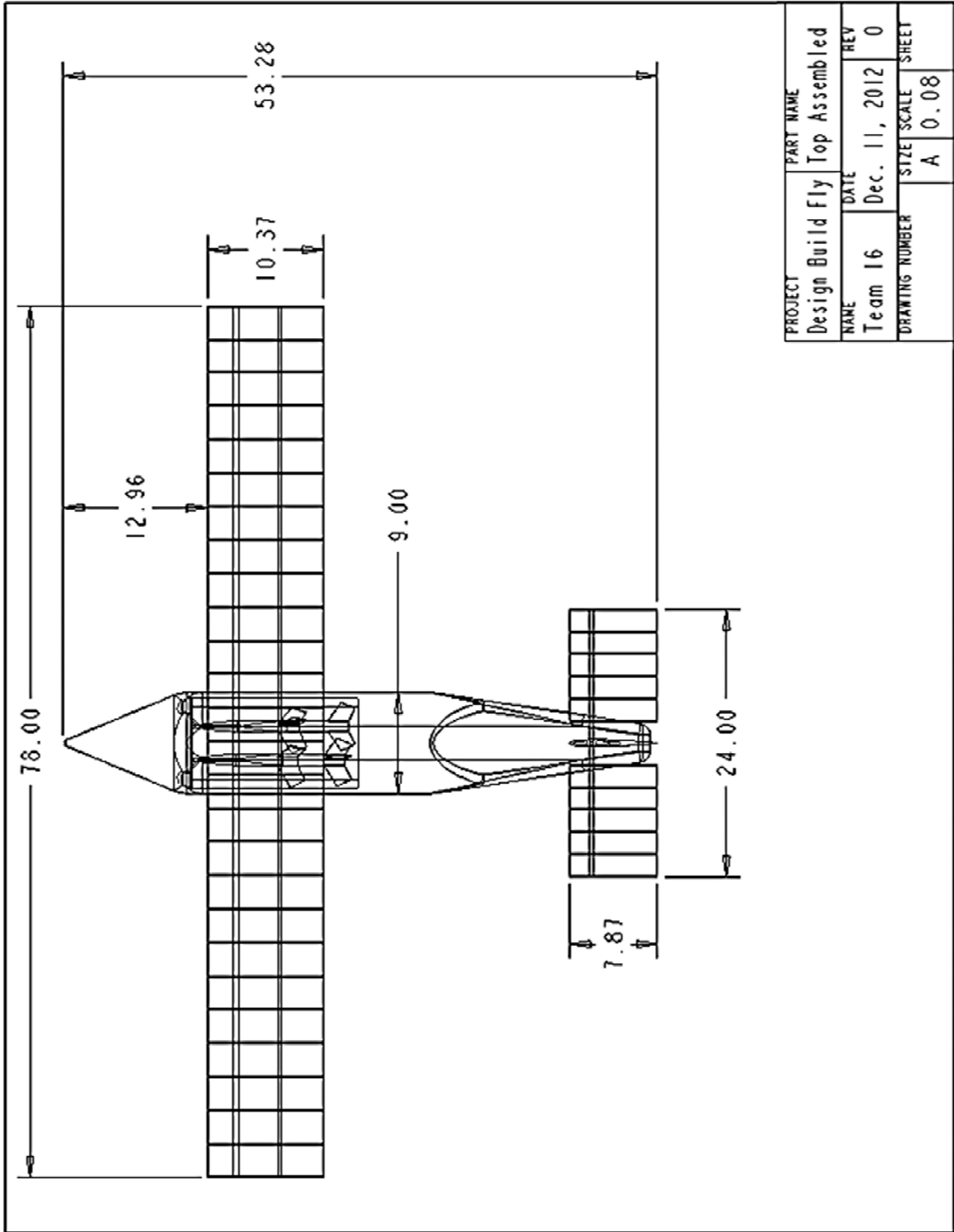

PROJECT	PART NAME		
Design Build Fly	Top Assembled		
NAME	DATE	REV	
Team 16	Dec. 11, 2012	0	
DRAWING NUMBER	SIZE	SCALE	SHEET
	A	0.08	