

2013 RASC-AL Robo-Ops Competition

Design for Manufacturing, Reliability, & Economics



**NATIONAL
INSTITUTE OF
AEROSPACE**



*Florida Agricultural & Mechanical University / Florida State
University College of Engineering*

Team Members:

Electrical and Computer Engineering

Ricardo Asencio

Matthew Wilson

Mechanical Engineering

Myles Bean

Daniel Bucken

Parker Harwood

Jason Rhodan

Project Advisors:

Dr. Jonathan Clark, PhD

Department of Mechanical Engineering

Dr. Michael Frank, PhD

Department of Electrical and Computer Engineering

Table of Contents

Abstract	3
Introduction	3
Prototype Design	3
Changes Made from Prototyping Challenges	4
Design for Reliability	5
Design for Economics	6
Components to be Manufactured	7
In-House Manufactured Components	7

Abstract

This report discusses prototyping design and manufacturing, and overviews reliability and economical concerns regarding the Team 11 senior design project SPACE-HEX for the 2013 RASC-AL Robo-Ops Competition. XRL and Hexcavator were used to prototype the systems SPACE-HEX needs to accomplish its mission at the Johnson Space Center Rock Yard in Houston, Texas at the competition in June of 2013. The reliability of SPACE-HEX's mechanical systems were maximized through the use of moderate tolerances, and high-strength oriented component design. Simple geometry parts were developed to be manufactured in-house at the FAMU-FSU College of Engineering machine shop. High-precision parts manufacturing was outsourced. Electronics with higher reliability were acquired to eliminate problems encountered with Hexcavator, but this has caused the necessary project budget to exceed the team's current available funding.

Introduction

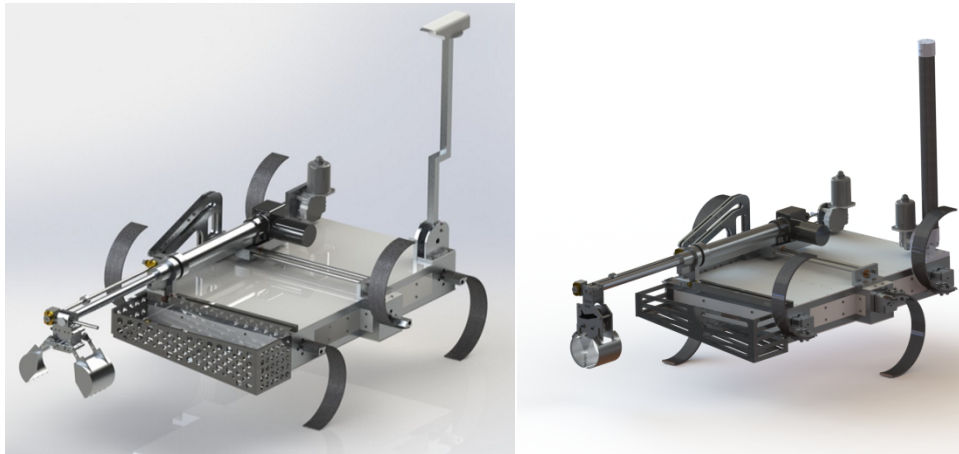

Figure 1: Renders of SPACE-HEX from December, 2012 (left) and from March, 2013 (right). Major visible changes were made to the Rock Gripper, Camera Mast, and Leg Mounts.

Team 11 has been developing its rover, SPACE-HEX, to meet the mission requirements of the 2013 RASC-AL Robo-Ops competition since January 2013. The competition-spec rover has been designed and developed to endure the expected environment at Johnson Space Center (JSC) Rock Yard with funds and resources from NASA, the FAMU-FSU College of Engineering, and various corporate and institutional sponsors. SPACE-HEX's subsystems have been built and tested independently using prototype hardware while the new rover's components were being designed and manufactured. The problems encountered during prototyping have led to an unexpected late influx in expenses, but have also allowed the team to develop a more robust final product.

Prototype Design

Prototyping for SPACE-HEX was done using existing hardware from the Scansorial and Terrestrial Robotics and Integrated Design Lab (STRIDe Lab) and the previous year's senior design project. 2012 Lunabotics entrant, Hexcavator; and the STRIDe Lab's XRL robot were specifically used in prototyping and development. Hexcavator was used to develop the computing architecture and algorithms for use in SPACE-HEX'S mobility systems. Its motor drivers from the Open-Source Motor Control project (OSMC) were used with SPACE-HEX's Xula2 Field Programmable Gate Array (FPGA) and Raspberry Pi

minicomputer for locomotion development. Also its payload was scavenged for hardware, mainly a linear actuator, to prototype the Sample Extraction Module (SEM) on a wooden mock-up of SPACE-HEX.

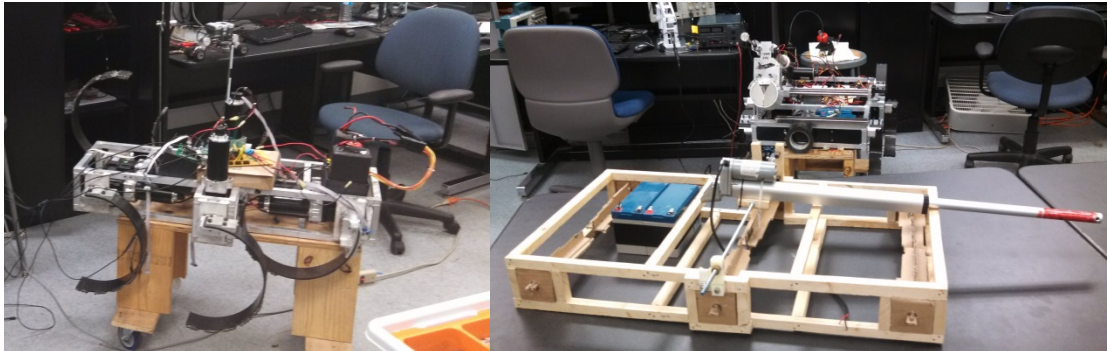

Figure 2: Hexcavator locomotion testing platform (left) and the wooden SPACE-HEX mock-up (right).

XRL was used as a scaling tool to properly size SPACE-HEX. Due to the competition's 45kg weight restriction, it was critical to properly downsize the 65kg Hexcavator. XRL's chassis and leg dimensions were reduced to a scaling factor for sizing SPACE-HEX. This scaling factor was used to properly specify the chassis dimensions, and the length and width of SPACE-HEX's legs to clear the 10cm obstacles expected according to the competition design guidelines.

Changes Made from Prototyping Challenges

The initial plan was to use the lightest materials, like Aluminum and carbon-fiber, for most of SPACE-HEX's mechanical components. Steel guide rails are used on the SEM X- and Z-Axes for reinforcement and smoother operation. The rover was sized at 1.75x that of XRL to accommodate the selected Maxon motors that were longer and lighter than those on Hexcavator. The Rock Gripper was redesigned with a 4:1 chain drive to increase torque due to expected digging, and with a less complex casing design to reduce manufacturing complexity. The camera mast material was switched from Aluminum to carbon-fiber to reduce weight and vibration encountered from testing, and the mast is raised unpowered contrary to the initial design.

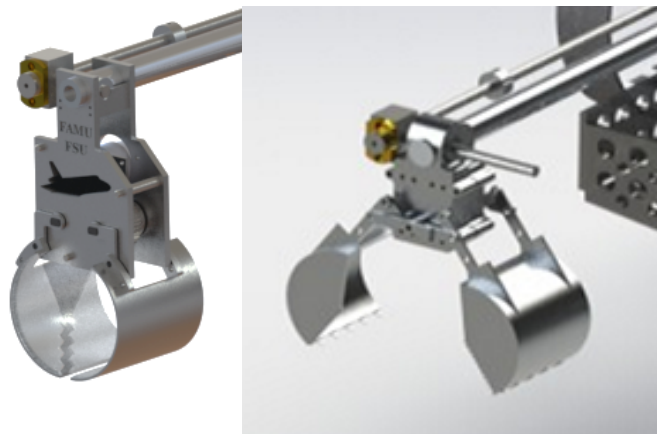

Figure 3: New rock gripper with 4:1 chain drive and gear mesh (left) vs. old servo driven design (right).

Only three Sabretooth leg motor drivers replace the original six OSMC motor drivers. This reduces complexity, and allows for the leg motors' Raspberry Pi and FPGA to be powered

from one of the motor drivers' 5V regulated output terminals. A second Raspberry Pi was added to separate control of the SEM and locomotion due to issues with multiplexing to only one minicomputer. This configuration change led to necessary programming changes, as the new motor drivers require serial communication instead of the Pulse-width Modulation (PWM) signaling from the OSMC set-up. Finally, the rover's power system has the locomotion and SEM motor drivers powering their respective Raspberry Pi computers, with networking and vision systems being powered through a separate 12V regulator.

Design for Reliability

SPACE-HEX was broken up into several major subsystems for design: the chassis, power system, electronics, networking, SEM, vision system, mission control, and mobility system. Since the rover is expected to operate for one hour, predominantly unassisted at JSC, the reliability of the rover's subsystems is of critical importance. Thus each subsystem was developed to handle the most extreme possible failure mode, but with the lightest feasible materials.

The chassis design is a space-frame made out of thin-wall 6000-series Aluminum square tubing. Interior volume is almost entirely occupied by the electronics, power system, and locomotion motors. ABS plastic plating is used to protect the interior of the chassis from debris and moisture from the surrounding environment. Since the chassis is to hold over 100lbs of subsystem hardware, it is properly structured to eliminate deflecting under load. This affected the specification of the locomotion system, and thus the legs are made of 23 layers of carbon-fiber to provide more stiffness than was needed. The leg motors, from Maxxon Motors, were selected to provide more than enough torque to stand and propel the rover. All mounts for external subsystems are made of $\frac{1}{4}$ or $\frac{1}{8}$ in thick 6000 series Aluminum to save additional weight yet maintain strength.

The electronics contained within SPACE-HEX's chassis were selected to handle the processing and power demands of the rover's subsystems. A Raspberry Pi minicomputer coupled with a Xula 2 FPGA provides PD-controlled locomotion signals to three Sabretooth 2-channel, high power motor drivers. The SEM has its own Raspberry Pi minicomputer that controls two low power, two-channel motor drivers for the SEM's linear actuator, X-Axis motor, and rock gripper motor. Power trickles down from batteries through the motor controllers to "extremities" at motors, and computers. The motor drivers eliminate the need for multiple power regulators that may reduce energy efficiency, and provide stable power flow to the Raspberry Pi mini computers, leg motors, and SEM actuators.

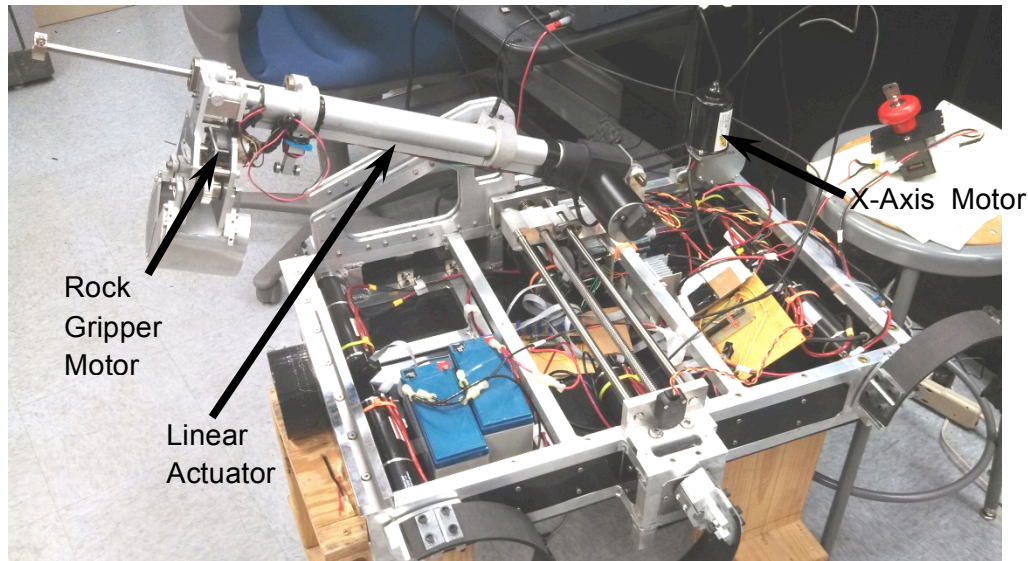

Figure 4: Diagram explaining SEM motors.

The networking systems aboard SPACE-HEX are required for the rover to communicate with Mission Control in Tallahassee from JSC over a commercial broadband network. Also, an on-board video feed must be broadcast from the rover to NASA and Mission Control over the same network. Since Verizon Wireless is reported to have cellular towers at JSC according to the competition guidelines, a Verizon 3G/4G USB modem and data plan were purchased to access the most stable connection available on-site. IP cameras are used to eliminate the need for on-board video processing, thus freeing computing memory at the expense of network bandwidth. Finally, a 3G/4G compatible TP-Link router is used to network all communicating hardware with the rover's internet connection.

Design for Economics

In general, planetary rovers are not economical products. NASA's Mars Science Laboratory ("Curiosity"), and the Mars Exploration Rovers ("Spirit" and "Opportunity"), had enormous budgets for their development, launch, and operation. The team didn't expect expenses to be anywhere near those amounts, but relatively great expenses were anticipated. The team sought sponsorships from as many different sources as possible to provide funding and resources for the development of SPACE-HEX, on top of the \$5,000 received from NASA from being selected to compete. About \$10,500 has been raised to develop the rover, since then about \$9,000 has been spent to complete it, with about \$5,000 in additional projected expenses (awaiting word from NASA on second \$5,000 grant installment to cover this). Much of the team's recent expenses were covered through sponsorship from Dr. Shih and the STRIDe Lab.

Project costs have exceeded initial estimates mostly due to the unexpected replacement of damaged or defective hardware. Low-reliability Open Source Motor Control project (OSMC) motor drivers inherited from Hexcavator consumed funds with re-work on development of small circuit boards during locomotion troubleshooting. Eventually, these motor drivers were replaced with new Sabertooth 2-channel motor drivers. Replacing damaged Raspberry Pi computers consumed more funds, and a new FPGA was purchased since the one on-hand had developed bad connection pins. A new power system was deemed necessary from

prototyping, and plans are to purchase new batteries with the last funding installment from NASA.

Components to be Manufactured

The design intent of most mechanical hardware was to minimize in-house manufacturing and make the most of the team's Misumi USA sponsorship. Most precision-parts were manufactured by and purchased from sponsor Misumi USA; these included gears and sprockets for the Rock Gripper, SEM guide rails, specialty fasteners and bearings, and material stock. All proprietary computing and networking hardware was purchased from outside vendors, but the circuitry that connects them was assembled in-house using lab equipment.

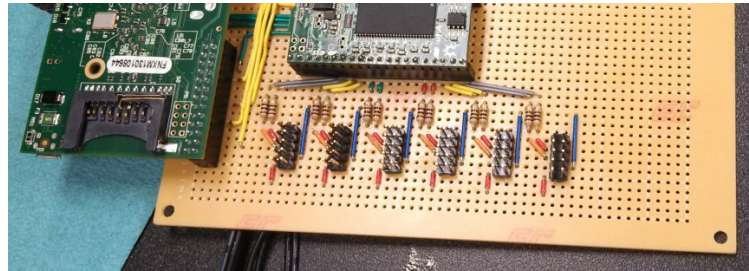

Figure 5: Just one iteration of SPACE-HEX's custom circuitry integrated with a Raspberry Pi minicomputer. This was originally developed to interface the Raspberry Pi (left of brown board), FPGA (center of brown board), and motor drivers.

In-House Manufactured Components

All components manufactured at the FAMU-FSU College of Engineering (COE) have simple geometry to minimize the complexity of the machinery required to make them. As a result, all such components were machined using a 3-axis mill, water-jet, and lathe at the COE advanced machine shop. The carbon-fiber legs required the most complex manufacturing process, and were made at the COE STRIDe Lab. The leg-mounts are the most geometrically complex parts, and were manufactured from billet Aluminum using a 3-Axis CNC vertical mill. A Bill of Material and Part Drawings of SPACE-HEX's manufactured parts are provided in the Appendices of this report.

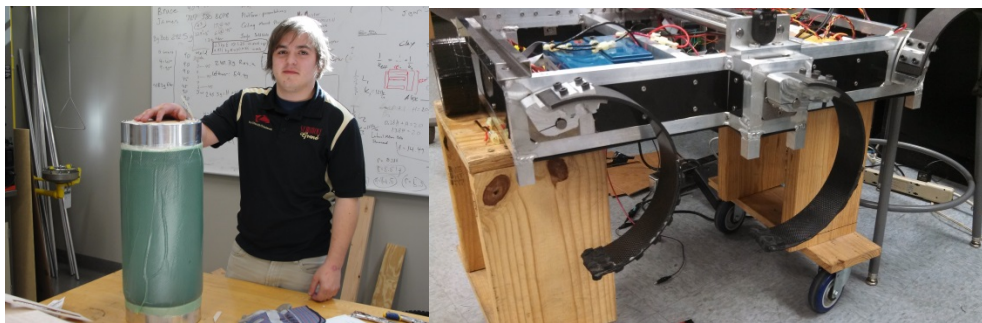

Figure 6: Carbon-fiber legs in mold after baking (left), and finish legs mounted to rover (right).