

Power Generation through Recycled Materials

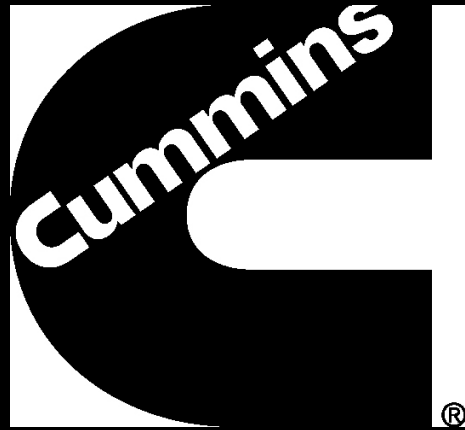

Team # 7:
Carlos Novelli
Jonathon Miller
Sean Stege

Sponsor: Cummins

Index

- **Background Overview**
 - Problem Statement
 - Objectives/Constraints
- **Motivation**
- **Design Layout**
- **Geographical Locations**
 - Wind
 - Water
- **Concept Designs**
 - Vertical Axis Wind Turbine
 - Horizontal Axis Wind Turbine
 - Water-Power Wheel
- **Additional Concept**
 - Tesla Turbine
- **Energy Conversion**
- **Power Storage**
- **RoHS**
- **Cost Analysis**
- **Decision Matrix**
- **Conclusion/Future Plans**
- **References & Questions**

Background Overview

- **Problem Statement:**

- Design and construct a power generation device that implements the use of a renewable energy source and is composed entirely of recycled materials

- **Objectives:**

- Must generate 100 W·h/day
- Must store 300 W·h

- **Constraints:**

- Must choose three different geographic locations
 - 100 km away from the ocean, 500 km away from each other
- Final product must cost under \$50

Motivation

- **Motivation:**
 - In many countries around the world there are people with scarce means of acquiring power
 - Lack of financial resources
 - Personal power generator can provide a valuable commodity
 - Earth's current energy crisis there is a huge surge towards using renewable resources to supply power
 - Wind power, water power, solar power
 - High value remaining in first world "trashed" materials

Design Layout

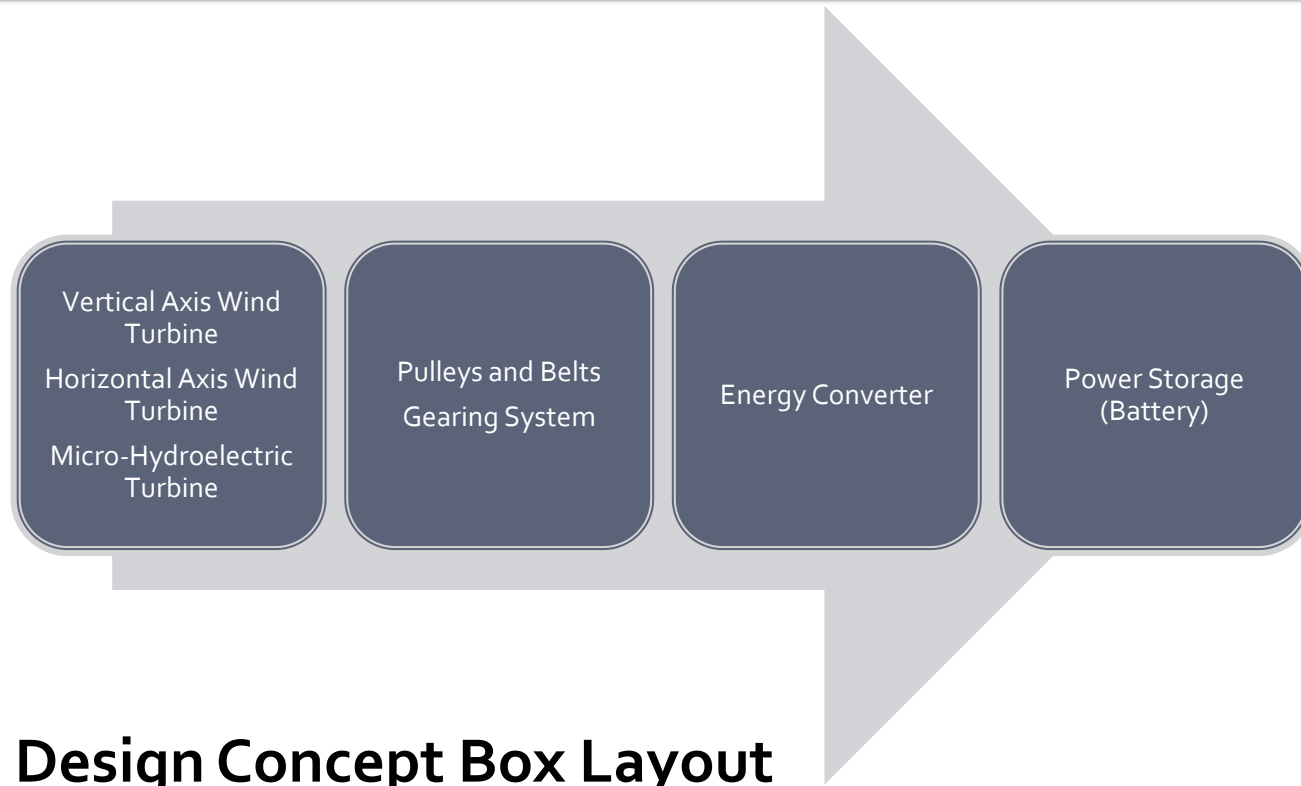

- **Design Concept Box Layout**

- Energy Capture → Speed Change → Energy Conversion → Battery Storage
- Simplicity with 4 component layout

Geographical Locations

Wind Energy Locations

- Faya-Largeau, Chad
 - Average wind speed = 4.6 m/s
~ 10 m height
- Santa Cruz, Bolivia
 - Average Wind = 3.9 m/s ~ 10 m height
- Sen Monorom, Cambodia
 - Average Wind = 5.1 m/s ~ 10 m height

Water Energy Locations

- Atrato River, Colombia
 - Average Flow = $2.0 \cdot 10^6$ L/s
- Indus River, Pakistan
 - Average Flow = $6.5 \cdot 10^6$ L/s
- Benue River, Cameroon
 - Average Flow = $1.75 \cdot 10^5$ L/s



Boundary Layer Effects

- Average wind speed at 10m

Lat 17.917 Lon 19.117	Jan	Feb	Mar	Apr	May	Jun	Jul	Aug	Sep	Oct	Nov	Dec	AnnualAverage
10-year Average (m/s)	5.56	5.44	5.15	4.68	4.12	4.04	4.16	3.99	3.88	4.87	5	5.14	4.66

- Average wind speed at 50m

Lat 17.917 Lon 19.117	Jan	Feb	Mar	Apr	May	Jun	Jul	Aug	Sep	Oct	Nov	Dec	AnnualAverage
10-year Average (m/s)	7.04	6.88	6.52	5.93	5.21	5.11	5.26	5.05	4.91	6.17	6.3	6.51	5.9

- Annual approximate wind speed at 5 m = 4.0 m/s

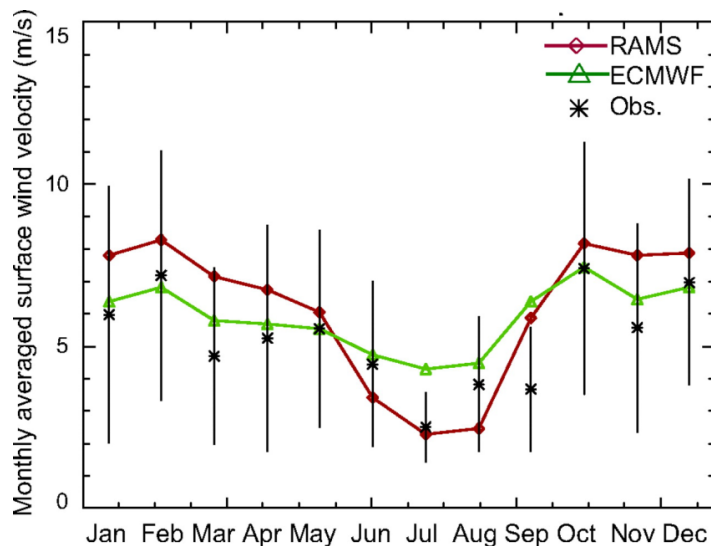

"Dust as a Tipping Element: The Bodélé Depression, Chad." *Proceedings of the National Academy of Sciences*. Web. 17 Nov. 2011.
 <<http://www.pnas.org/content/106/49/20564.full>>.

Design Concept #1: Vertical Axis Wind Turbine (VAWT)

■ Design Specifications

- Savonius design
- Drag based system

■ Available Wind Energy

- Average annual wind speed is ~4m/s (Faya-Largeau, Chad)

■ Calculation Analysis

- Power coefficient of turbine
- Minimum area of turbine
- Power generation
- Gearing/pulley ratio

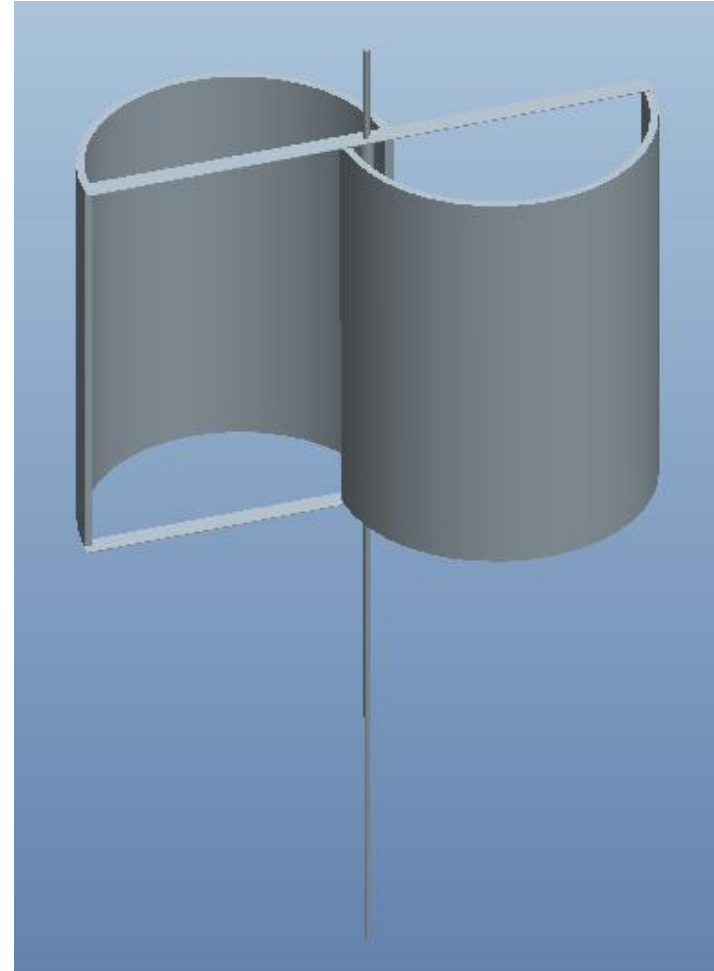

Design Concept #1: Vertical Axis Wind Turbine (VAWT)

- Example Velocity Flow Field – Ideal Savonius Design
 - $(e-e')/d=0.242$ and $ReD=1.56 \times 10^5$, i.e. $U=5\text{m/s}$
(unit : m/s)

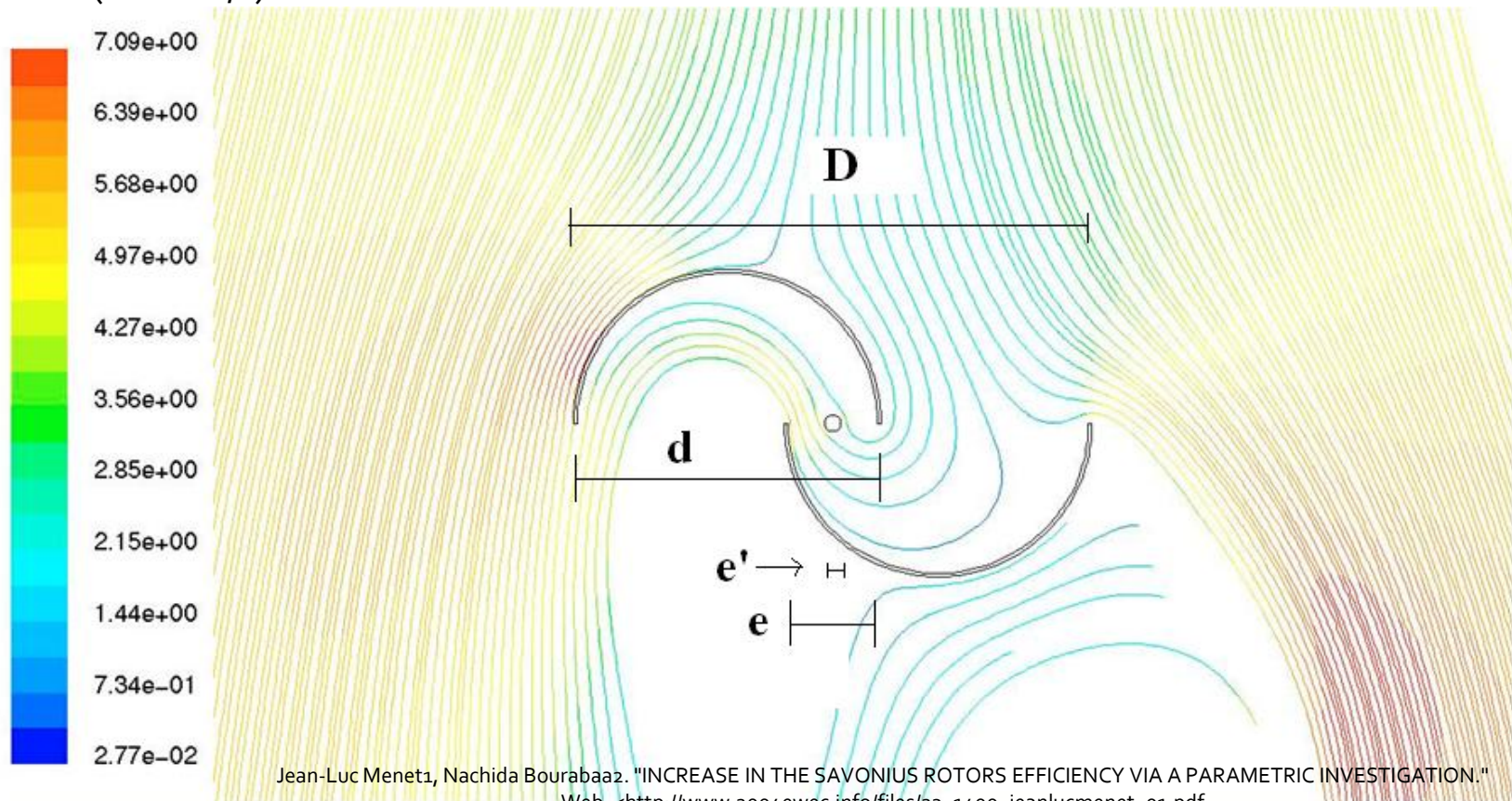

Design Concept #1: Vertical Axis Wind Turbine (VAWT)

■ Savonius Optimization

- Two blades & offset of e
- Wind vane apparatus to block and channel wind
- Optimized alternator/gearing
- Second turbine set at 90°
 - Provides self-starting
- $e_{opt} = d/6$

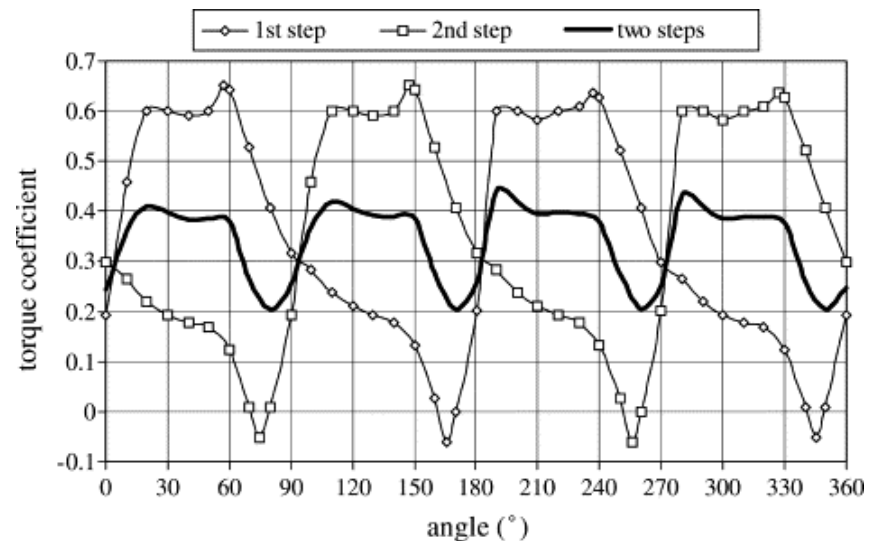

Jean-Luc Menet¹, Nachida Bourabaa². "INCREASE IN THE SAVONIUS ROTORS EFFICIENCY VIA A PARAMETRIC INVESTIGATION." Web. <http://www.2004ewec.info/files/23_1400_jeanlucmenet_01.pdf>.

Design Concept #1: Vertical Axis Wind Turbine (VAWT)

- With wind channeled, ratio of turbine tip speed to undisturbed wind speed, (λ) is approximately 1
 - Blocks wind incoming to convex portion
 - Channels wind into concave portion
 - Omni-directional

- $C_{p_{opt}} = 0.3$

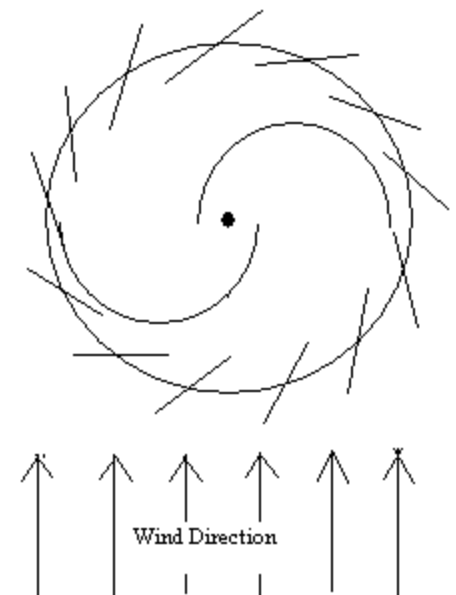
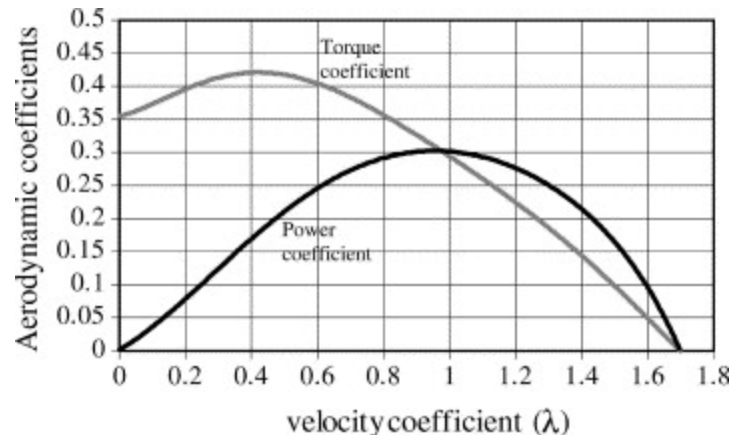

Design Concept #1: Vertical Axis Wind Turbine (VAWT)

IDEAL SAVONIUS SYSTEM

- Power coefficient of Turbine
 - 0.3
- Area Specifications
 - $e_{opt} = d/6$
 - $\alpha_{opt} = H/D = 4$
 - $e'_{opt} = e_{opt} - 0.242d$
- Power Generated
 - Gearing/pulley efficiency ~ 96%
 - Alternator efficiency ~90%

$$P_{actual} = \left(\frac{\rho H D V^3}{2}\right) (turbine\ efficiency) (belt\ efficiency) (alternator\ efficiency)$$

VAWT DESIGN CONCEPT #1

- Power Coefficient of Turbine (80% of ideal design):
 - 0.24
- Minimum Rotor Area (4.2 W)
 - Area = $0.579\text{ m}^2 = 2[d - (d/6)]H$
- Design Specifications
 - 2- rotor design
 - 90° offset
 - Area = 1.563 m^2
- Power Generated
 - Gearing/pulley efficiency ~ 85%
 - Refurbished alternator/motor efficiency ~ 80%
 - ~ 10 W

Design Concept #1: Vertical Axis Wind Turbine (VAWT)

FINAL DESIGN SPECIFICATIONS

- **Area of Turbine**
 - $A > 1.563\text{m}^2$
 - $d_{\text{cylinder}} > 0.375\text{m}$
 - $H_{\text{turbine}} > 2.5\text{m}$
- **Material Selection**
 - PVC piping
 - Thinnest walls possible
- **Bicycle Dynamo/PM DC Motor**
 - Gearing system implemented with sprockets and chain located on bicycle
 - Turbine Shaft directly connected to bicycle wheel center
 - Creates favorable 54:1 ratio = 3828 rpm on dynamo ~ 12 V DC

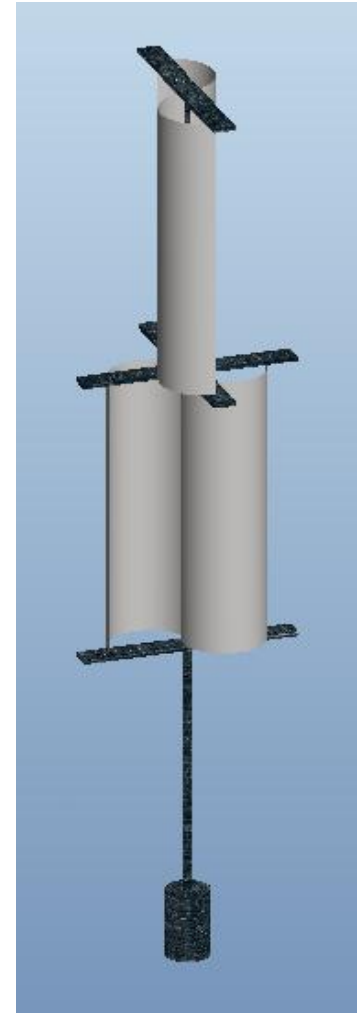

Design Concept #2: Horizontal Axis Wind Turbine (HAWT)

- **Design Specifications**
 - Three-blade turbine design
 - Airfoil shape in blades will be approximated
- **Available Wind Energy**
 - Average annual wind speed is ~4m/s (Faya-Largeau, Chad)
- **Calculation Analysis**
 - Power coefficient of turbine
 - Minimum area of rotor required
 - Power generation
 - Gearing/pulley ratio

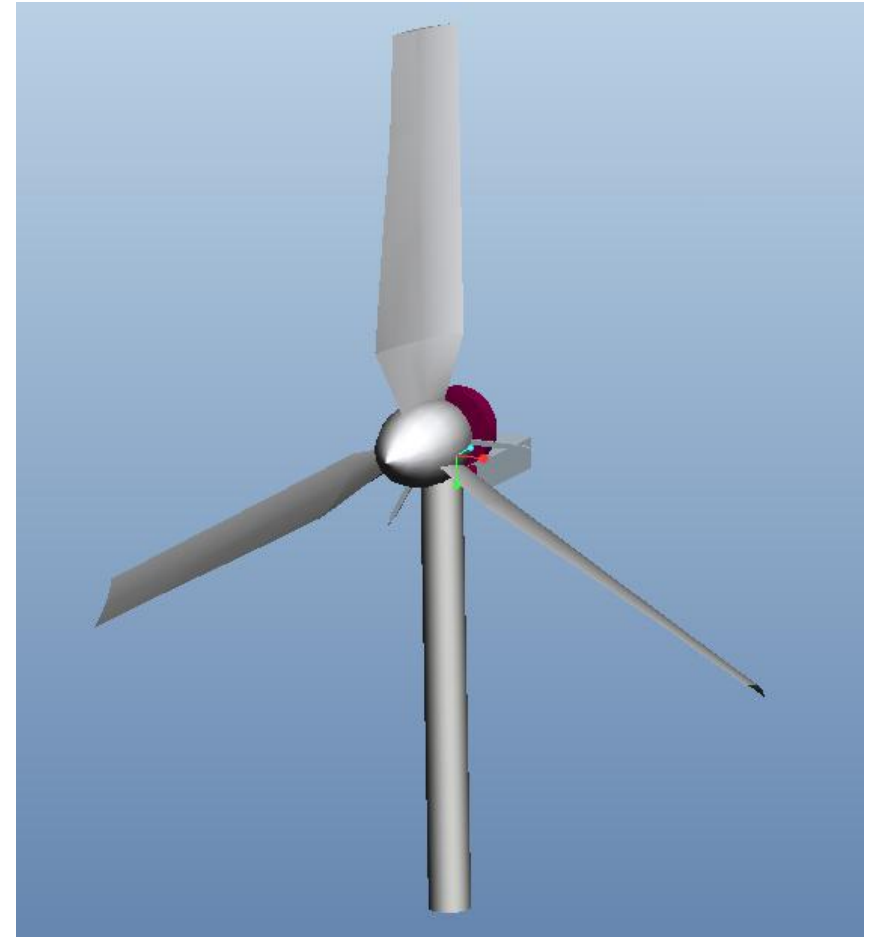

Design Concept #2: Horizontal Axis Wind Turbine (HAWT)

ARE442 WIND TURBINE (NREL)

- **Power coefficient of Turbine**
 - 0.190
- **Minimum Rotor Area (4.2 W)**
 - Area = 0.625 m²
 - Diameter = 0.912 m
- **Design Specifications**
 - 3-blade Design
 - 7.2 m rotor diameter
- **Power Generated**
 - Gearing/pulley efficiency ~ 96%
 - New alternator efficiency ~90%
 - ~ 525 W

$$P_{gen} = \frac{1}{2} \rho U_1^3 A C_p (\eta_{Belt} \eta_{Alternator})$$

HAWT DESIGN CONCEPT #2

- **Power Coefficient of Turbine (60% of ARE 442):**
 - 0.114
- **Minimum Rotor Area (4.2 W)**
 - Area = 1.39 m²
 - Diameter = 1.33 m
- **Design Specifications**
 - 3-blade design
 - 2.05 m rotor diameter
 - Area = 3.29 m²
- **Power Generated**
 - Gearing/pulley efficiency ~ 85%
 - Refurbished alternator/motor efficiency ~ 80%
 - ~ 10 W

Design Concept #2: Horizontal Axis Wind Turbine (HAWT)

ARE₄₄₂ WIND TURBINE (NREL) – POWER COEFFICIENT VS. WIND SPEED

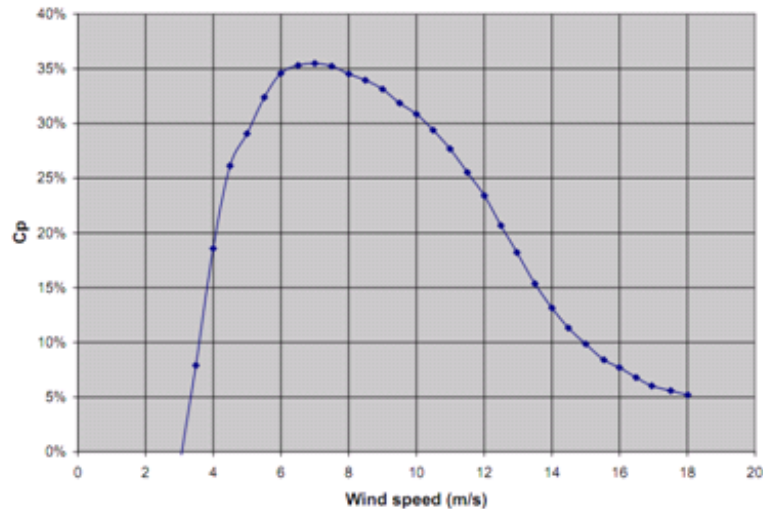

ARE₄₄₂ WIND TURBINE (NREL) – POWER GENERATED VS. WIND SPEED

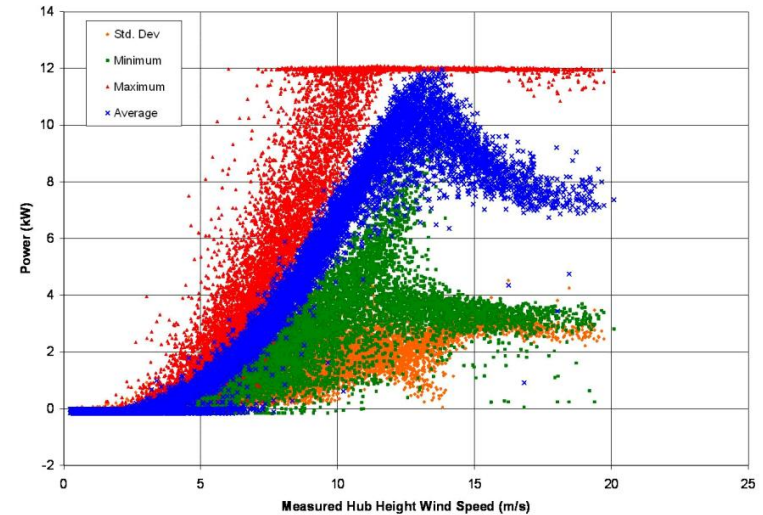

Design Concept #2: Horizontal Axis Wind Turbine (HAWT)

- **Blade Optimization**
 - Airfoil approximation from PVC
 - Initially cut into quarters
 - Draw straight lines along center lengths
 - Draw diagonal straight lines ~ 9°



Design Concept #2: Horizontal Axis Wind Turbine (HAWT)

■ Gearing/Pulley System

- Angular rotor velocity (ARE442)
 - 48 rpm
- Alternator angular velocity
 - ~700 rpm
- 15:1 - Gear ratio

■ Bicycle Dynamo

- 67.5:1 ratio created from bicycle wheel to dynamo
- 3240 rpm produced ~ 12 V DC

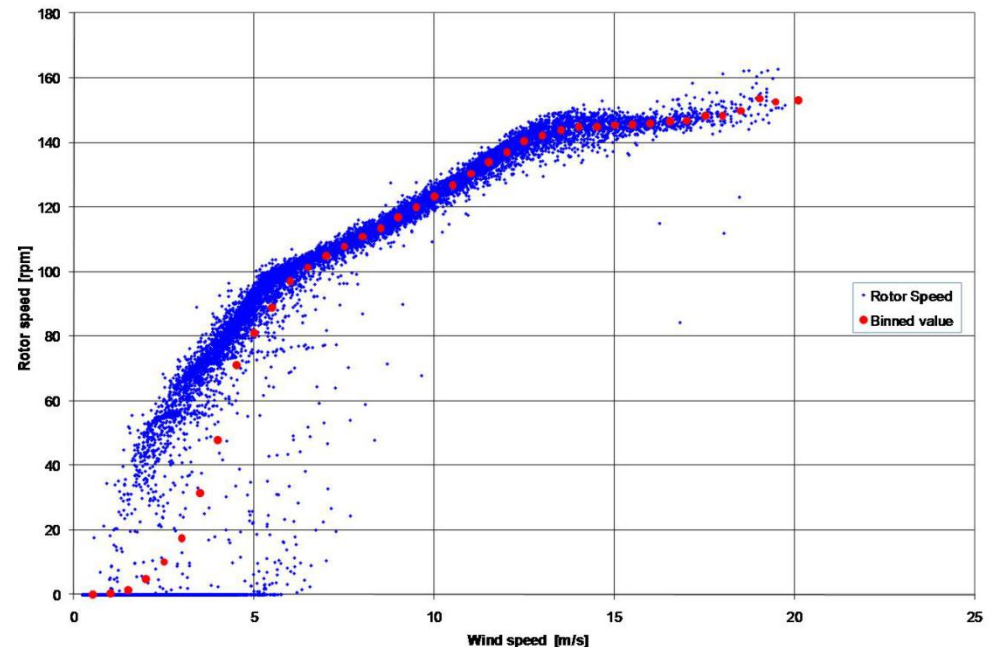

Wind speed	[m/s]	0.5	1.0	1.5	2.0	2.5	3.0	3.5	4.0	4.5	5.0	5.5	6.0	6.5	7.0	7.5	8.0	8.5	9.0	9.5	10.0
Rotor speed	[rpm]	0	0	1	5	10	17	31	48	71	81	89	97	101	105	108	111	114	117	120	123

Wind speed	[m/s]	10.5	11.0	11.5	12.0	12.5	13.0	13.5	14.0	14.5	15.0	15.5	16.0	16.5	17.0	17.5	18.0	18.5	19.0	19.5	20.1
Rotor speed	[rpm]	127	130	134	137	140	142	144	145	145	145	145	146	147	147	148	148	150	154	152	153

Van Dam, Jeroen. "Wind Turbine Generator System Power Performance Test Report for the ARE442 Wind Turbine." National Renewable Energy Laboratory, Feb. 2010. Web. 17 Nov. 2011.
 <http://www.nrel.gov/wind/smallwind/pdfs/are_power_performance_test_report.pdf>.

Design Concept #3: Micro-Hydroelectric Generator

- **Design Specifications:**
 - Paddle- Wheel (8 Bamboo fins)
 - Floats while charging battery
- **Available Water Energy:**
 - Atrato River, Columbia
 - Indus River, Pakistan
 - Benue River, Cameroon
- **Calculation Analysis**
 - Velocity of flow is primary influence on power production
 - Power generation
 - Gearing

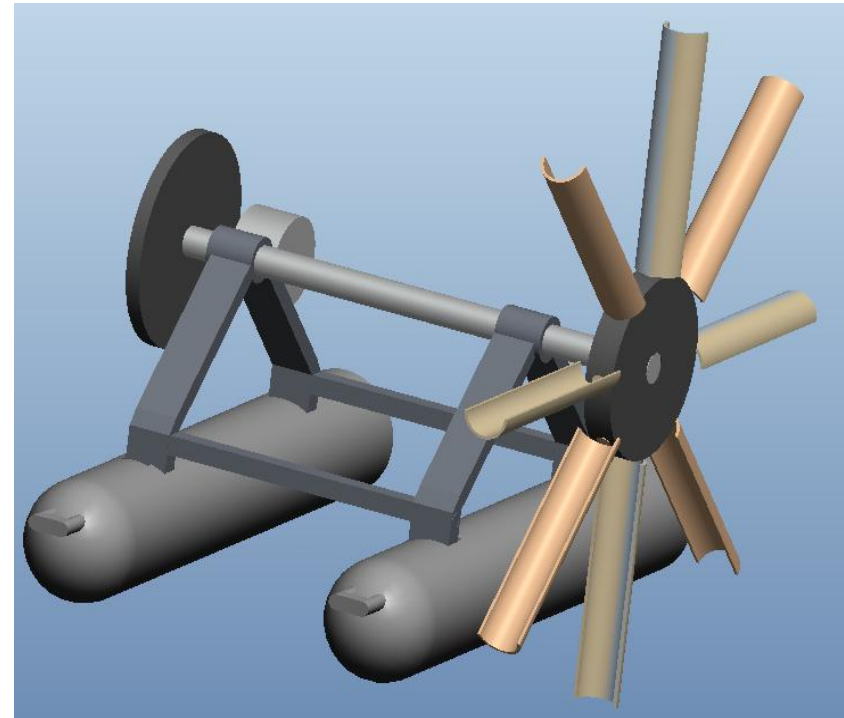

Design Concept #3: Micro-Hydroelectric Generator

■ Power Generation

- No actual head accelerating flow since generator is floating
- Gross Head- vertical distance water would fall in order to reach flow velocity

		Power Output (Watts)				
		Velocity (ft/s)				
Gross Head (ft)	3	6	10	15	20	
0.139	2.99	5.98	9.97	14.9	19.9	
0.559	11.9	23.9	39.9	59.8	79.8	
1.55	33.2	66.5	110	166	221.7	
3.49	74.8	149.6	249	374	498	
6.21	133.0	266	443.	665	886	

$$GrossHead = \frac{velocity^2}{2 * g}$$

$$Power = GrossHead * \frac{ft^3}{s} * Eff * 8.5$$

Design Concept #3: Micro-Hydroelectric Generator

- **Paddle-Wheel Optimization**
 - Use indigenous bamboo to reduce our cost and utilize locally abundant resources
 - Bamboo is lightweight and holds up well in water
 - 8 fins so at least two are in contact with the water at all times

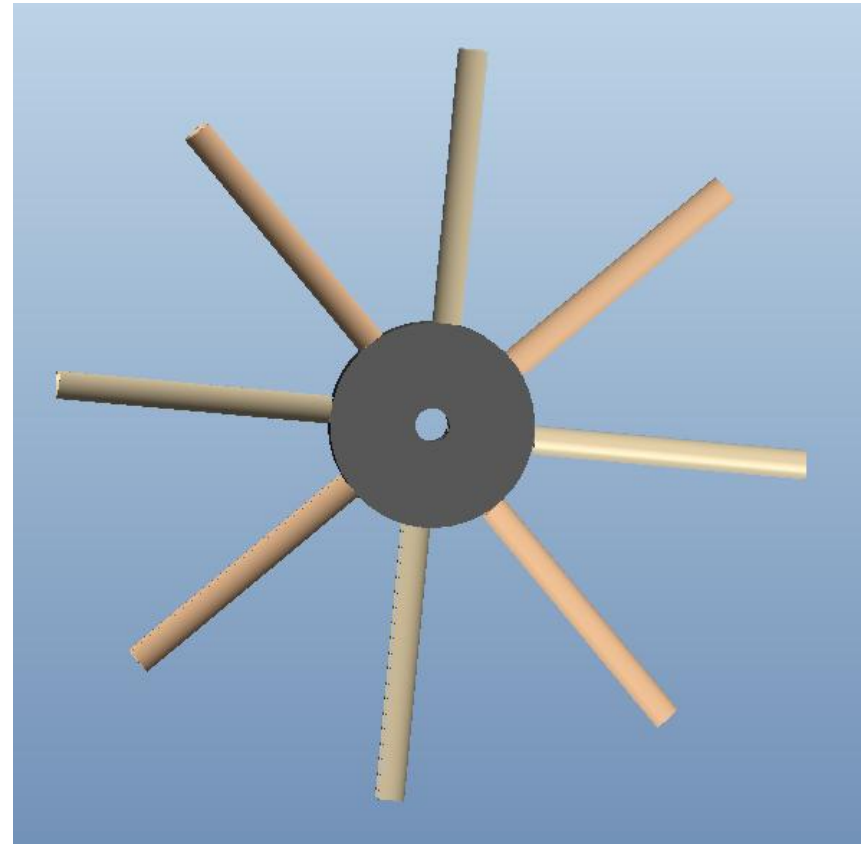

Additional Concept: Tesla Turbine

- **Complexity**
 - Necessary scale will make design impractical
 - Requires precise installation
 - High maintenance required
 - Water flow can consistently damage discs
- **Large Size**
- **Water Filtration System**

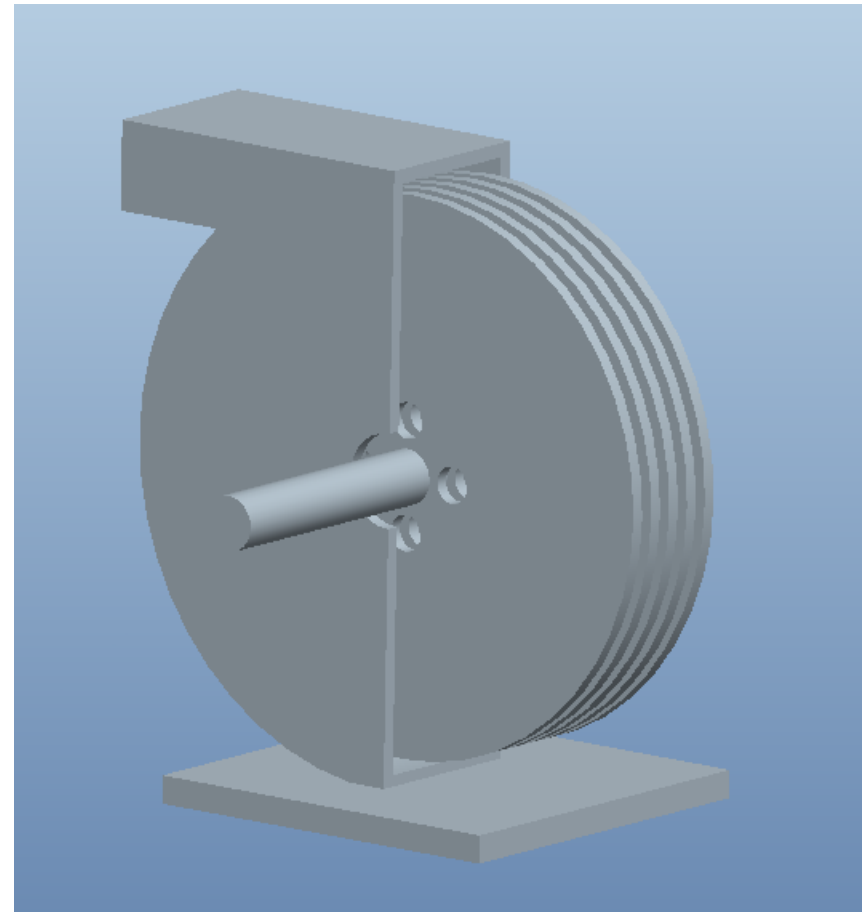

Energy Conversion

ALTERNATOR

- Efficiency ranges from 90-95%
 - Used alternator approximated as 80% efficient
- Wide variety and easily obtainable/replaceable
- Design rpm much lower, gearing required
 - Minimum rpm = 700
 - Maximum rpm = 6,000

DYNAMO OR DC MOTOR

- Efficiency ranges from 85-95%
 - Used approximated as 80% for uniformity
- Less costly than alternator
- Widely available
- Produces current at all speeds
 - Requires voltage regulator
 - Dynamo requires bicycle
- Ideal rpm ~3000

Power Storage

REQUIREMENTS

- 12V
- Store 300W·h

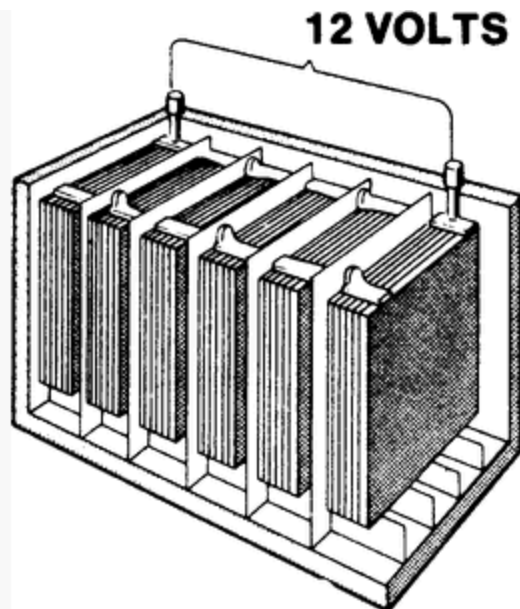

CAR BATTERY

- New Battery ~ 3500W·h
- Used Battery/Refurbished
 - Assume 70% original capacity ~ 2450W·h
 - Charging time ranges 10-13 hours, assuming constant voltage and at least 2 amps
- Germanium/Silicon Diode
 - Rectify voltage
 - Prevent power from leaking out to the Dynamo
- Battery should be disconnected during periods of non-use in order to prevent overcharging

Restriction of Hazardous Substances (RoHS)

- Restriction of the Use of Certain Hazardous Substances in Electrical and Electronic Equipment
 - Mercury, Lead, Cadmium etc.
- Compliance is not required since we are not shipping to an EU member
 - By making sure the battery is clearly marked and accessible for end of life disposal we will be in compliance



Cost Analysis

Cost Analysis	Concept Design #1: VAWT	Concept Design #2: HAWT	Concept Design #3: MHEW
Rotational Component	\$2.00	\$3.00	\$2.00
Supporting Structure	\$2.00	\$2.00	\$10.20
Energy Converter	\$10.00	\$10.00	\$10.00
Gearing Assembly	\$2.00	\$2.00	\$2.00
Bearings	\$1.00	\$1.00	\$1.00
Energy Storage	\$19.79	\$19.79	\$19.79
Battery Cables	\$3.59	\$3.59	\$3.59
Total	\$40.38	\$41.38	\$48.58

Decision Matrix

		Concepts							
		VAWT		HAWT		Hydro-electric		Tesla	
Specifications	Importance Weight	Rating	Weighted Scores	Rating	Weighted Scores	Rating	Weighted Scores	Rating	Weighted Scores
Durability	15%	5	0.75	3	0.45	3	0.45	1	0.15
Ease of Assembly	20%	3	0.60	5	1.00	3	0.60	1	0.20
Cost	40%	5	2.00	5	2.0	1	0.40	3	1.20
Maintenance	20%	3	0.60	3	0.60	3	0.60	1	0.20
Innovative	5%	3	0.15	3	0.15	3	0.15	5	0.25
	Score	19	4.1	19	4.2	15	2.20	11	2.0

Durability	10%	5	0.50	3	0.30	3	0.30	1	0.10
Ease of Assembly	15%	3	0.45	5	0.45	3	0.45	1	0.15
Cost	30%	3	0.90	3	0.90	5	1.50	3	0.90
Maintenance	15%	3	0.45	3	0.45	3	0.45	1	0.15
Efficiency	30%	1	0.30	1	0.30	5	1.50	1	0.30
	Score	15	2.6	15	2.4	19	4.20	7	1.60

Future Plans

- Teleconference with Cummins
 - Bi-weekly teleconferences with the Cummins rep. Terry Shaw
- Three designs will be pursued and constructed
 - Vertical Axis Wind Turbine
 - Horizontal Axis Wind Turbine
 - Micro-Hydroelectric Wheel
- Purchase required materials
 - Return to junkyards and recycle facilities
 - Purchase a wide variety of parts in order to optimize designs
- Construct, test, and refine prototype

References

- In Scopus. "ScienceDirect - Renewable Energy : A Double-step Savonius Rotor for Local Production of Electricity: a Design Study." *ScienceDirect - Home*. Web. 16 Nov. 2011. <<http://www.sciencedirect.com/science/article/pii/S0960148104000916>>
- Jean-Luc Menet¹, Nachida Bourabaa². "INCREASE IN THE SAVONIUS ROTORS EFFICIENCY VIA A PARAMETRIC INVESTIGATION." Web. <http://www.2004ewec.info/files/23_1400_jeanlucmenet_01.pdf>.
- "Dust as a Tipping Element: The Bodélé Depression, Chad." *Proceedings of the National Academy of Sciences*. Web. 17 Nov. 2011. <<http://www.pnas.org/content/106/49/20564.full>>.
- "Meteorology (Wind) - Pivot Data - Faya-Largeau, Republic of Chad." *Метеоданные для Чада*. Web. 17 Nov. 2011. <<http://chad-meteo.ru/en/faya-larzho/pivot/wind>>.
- Van Dam, Jeroen. "Wind Turbine Generator System Power Performance Test Report for the ARE442 Wind Turbine." National Renewable Energy Laboratory, Feb. 2010. Web. 17 Nov. 2011. <http://www.nrel.gov/wind/smallwind/pdfs/are_power_performance_test_report.pdf>.
- Ross, Tom. "NCDC: Global Measured Extremes of Temperature and Precipitation." *NCDC: * National Climatic Data Center (NCDC) **. Web. 15 Nov. 2011. <<http://www.ncdc.noaa.gov/oa/climate/globalextremes.html>>.
- "Design of an Overshot Waterwheel." *French River Land Company's Home Page!* Web. 15 Nov. 2011. http://www.frenchriverland.com/design_of_an_overshot_waterwheel.htm.

Questions?
