

TWO-STEP HUB DEPLOYMENT MECHANISM



Team 5:
Noah Nichols
Chris Rudolf
Audrey Wright

PROBLEM STATEMENT

- ✘ Design a hub mechanism to deploy a segmented solid reflector
- ✘ Create a CAD model to show the dynamic simulation and a scaled prototype

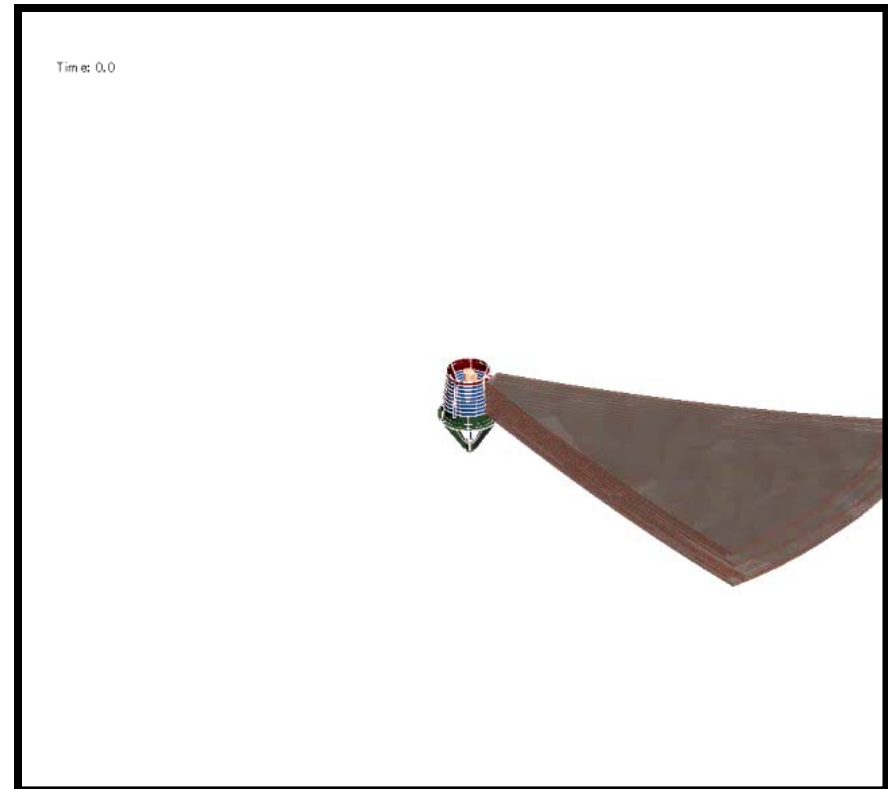

CONCEPT REQUIREMENTS

- ✘ Must rotate panels into position and retract them into the same surface plane while maintaining desired spacing between panels during deployment
- ✘ Two ways to retract panels into position
 - + Two separate motions
 - + Step down motion

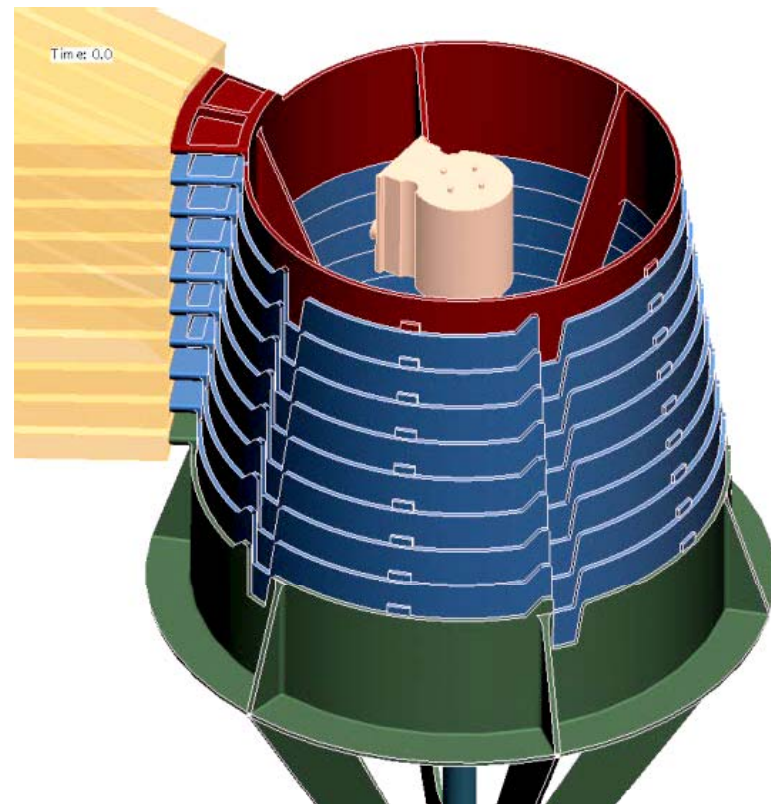

DECISION MATRIX

- ✘ Analysis will allow further refining of ratings and weights

Decision Matrix		Concepts					
		Synchronized Two Step Deployment		Spring Implementation		Guide Slots	
Specification	Weight	<i>Rating</i>	<i>Weighted Score</i>	<i>Rating</i>	<i>Weighted Score</i>	<i>Rating</i>	<i>Weighted Score</i>
Reliability	0.4	4	1.6	3	1.2	4	1.6
Durability	0.05	4	0.2	2	0.1	4	0.2
Weight	0.1	3	0.3	3.5	0.35	4	0.4
Efficiency	0.2	5	1	4	0.8	3	0.6
Ease of Construction	0.15	2	0.3	3	0.45	2.5	0.375
Cost	0.1	3	0.3	3.5	0.35	4	0.4
Total	1	3.7		3.25		3.575	

SYNCHRONIZED TWO STEP DEPLOYMENT

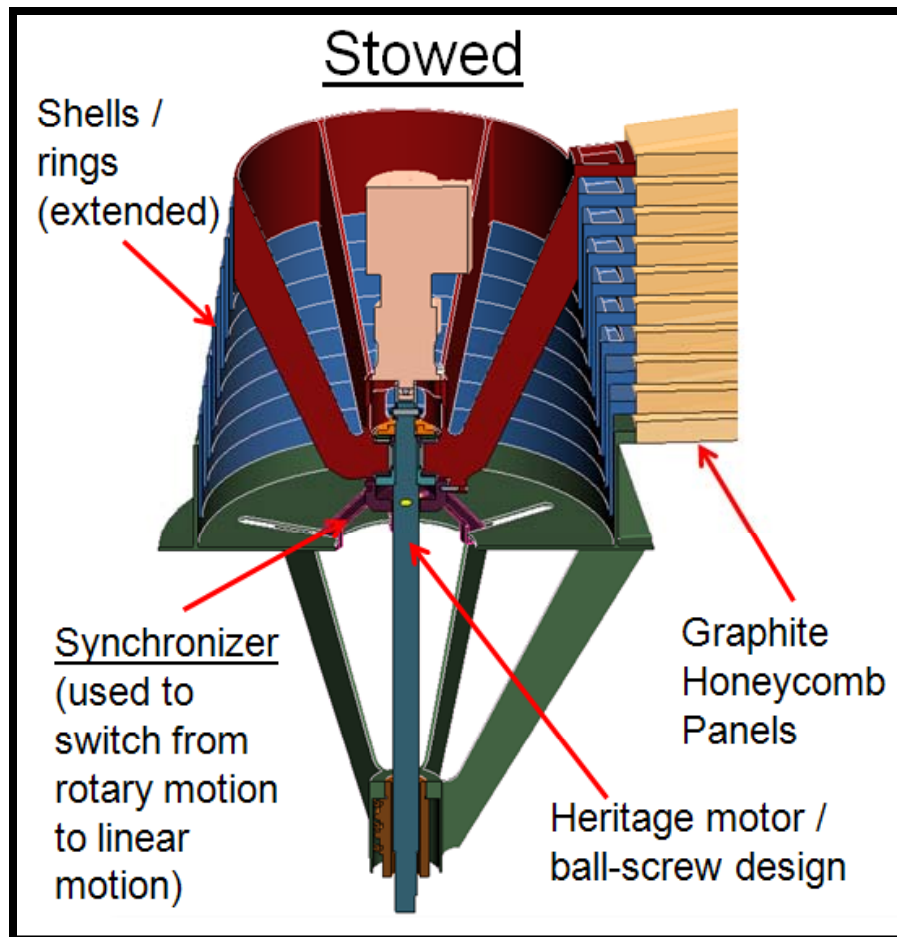

- ✘ Kinematic Analysis to determine forces
 - + Panel weight
 - + Ball screw torque
 - + Motor selection
- ✘ Finite element analysis to determine stresses
- ✘ Material Selection

KINEMATIC ANALYSIS

- ✘ What to expect from analysis
 - + Simulation of ideal/desired motion
 - + Determine if ring to panel sizing ratio is correct
- ✘ Rotational torque analysis for ball screw
- ✘ Motor sizing
- ✘ Ring sizing
- ✘ Panel weight

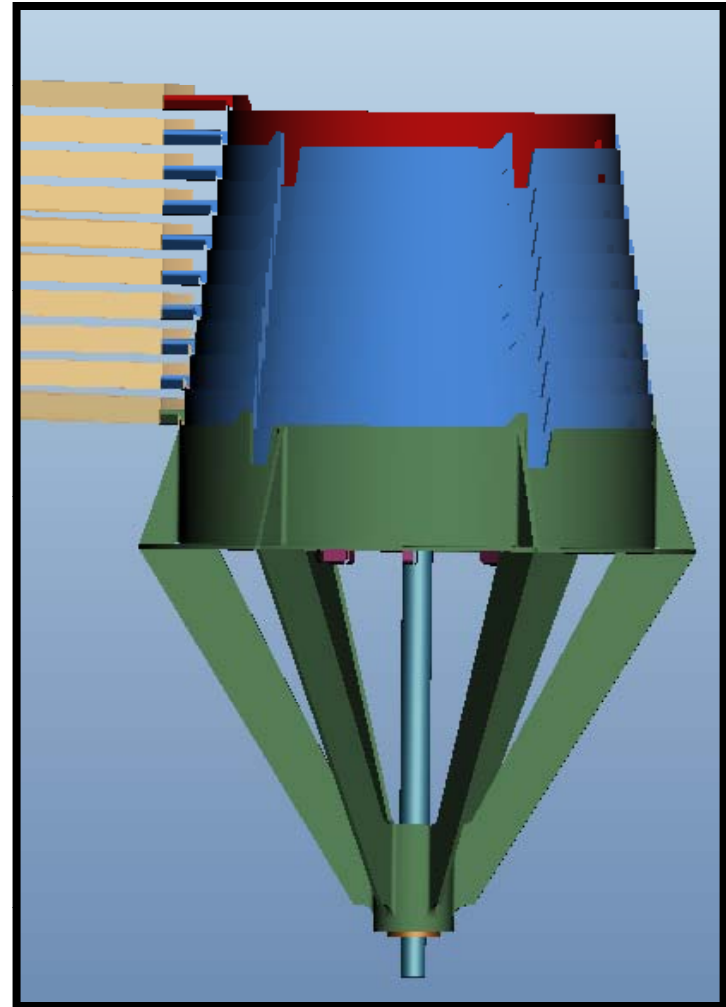

BALL SCREW ANALYSIS

- ✘ Calculations will be conducted to find the torque and loads in order to select the correct ball screw
 - + Permissible Axial Load and Rotational Speed
 - + Torque due to load
 - + Rotational Torque due to acceleration and deceleration

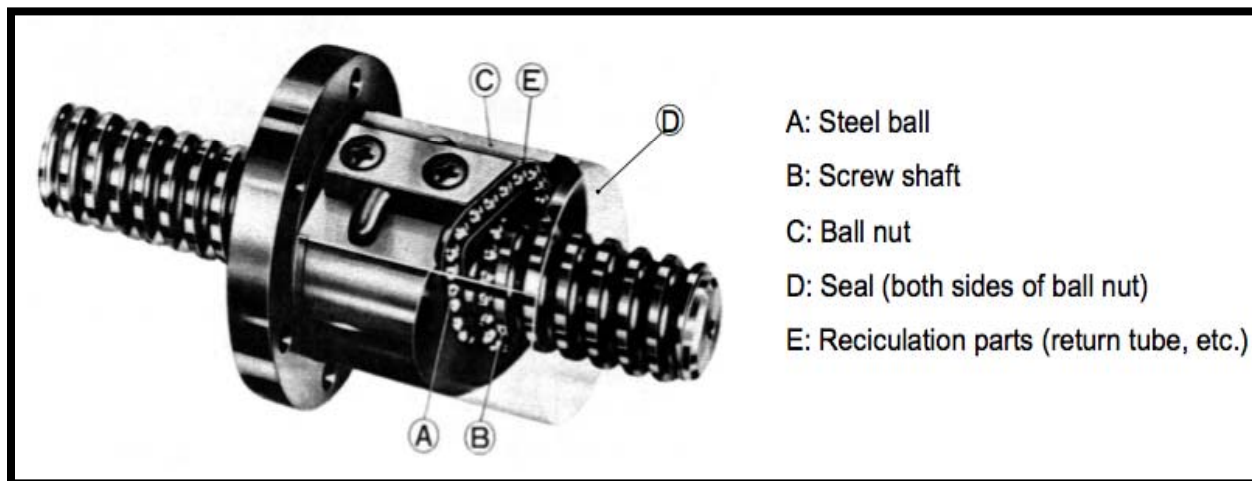

BALL SCREW CALCULATIONS

× Permissible Axial Load: $P_1 := \frac{\eta_1 \cdot \pi^2 \cdot E \cdot I}{l_a^2} \cdot 0.5$ $P_2 := \sigma \cdot \frac{\pi}{4} \cdot d_1^2$

× Permissible Rotational Speed: $N_1 := \frac{60 \cdot \lambda_1^2}{2\pi \cdot l_b^2} \cdot \sqrt{\frac{E \cdot 10^3 \cdot I}{\gamma \cdot A}} \cdot 0.8$

× Rotational Torque:

+ Uniform Motion: $T_t := T_1 + T_2 + T_4$

+ During Acceleration: $T_K := T_t + T_3$

+ During Deceleration: $T_g := T_t - T_3$

RAMP SLOT CONCEPT

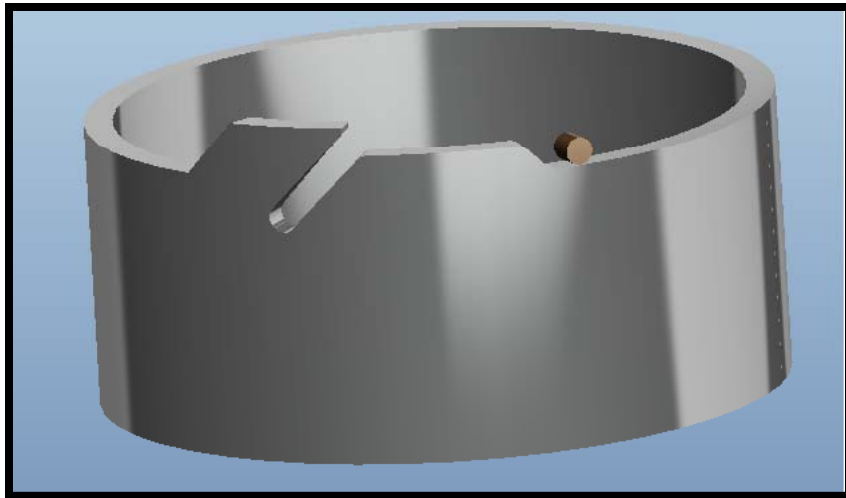

Example of single ring with barrel slider

- × Kinematic analysis to determine forces
 - + Panel weight
 - + Motor selection
- × Finite element analysis to determine stresses
- × Cam/follower analysis
- × Material selection

RAMP SLOT OPERATION

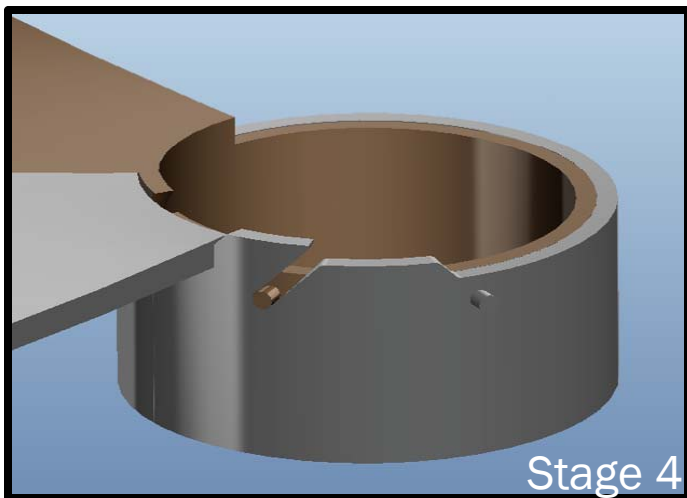
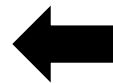
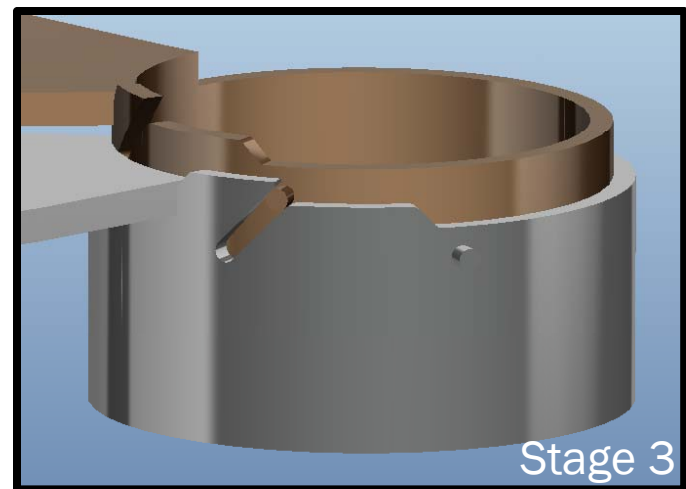
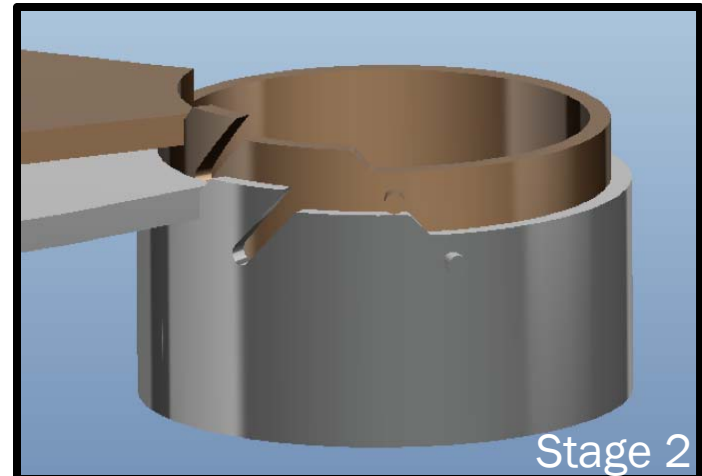
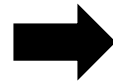
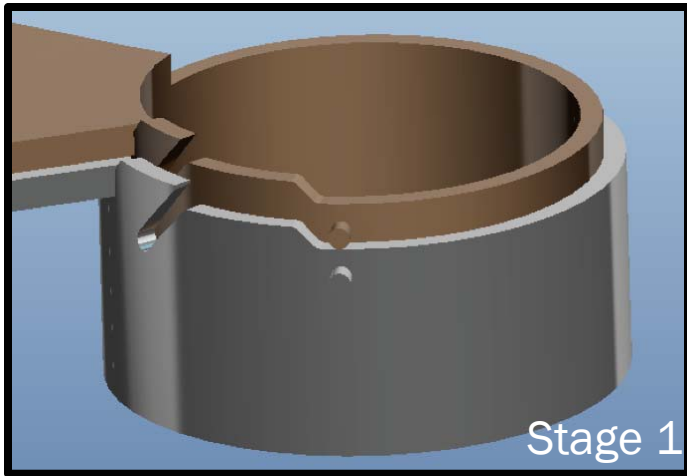

KINEMATIC ANALYSIS

- × What to expect from analysis
 - + Simulation of ideal/desired motion
 - + Determine if ring to panel sizing ratio is correct

- × Motor sizing

- × Ring sizing

- × Panel weight

CAM/FOLLOWER ANALYSIS

- ✘ Determine the best cam profile to ensure precise panel alignment.
- ✘ Determine appropriate follower/slider

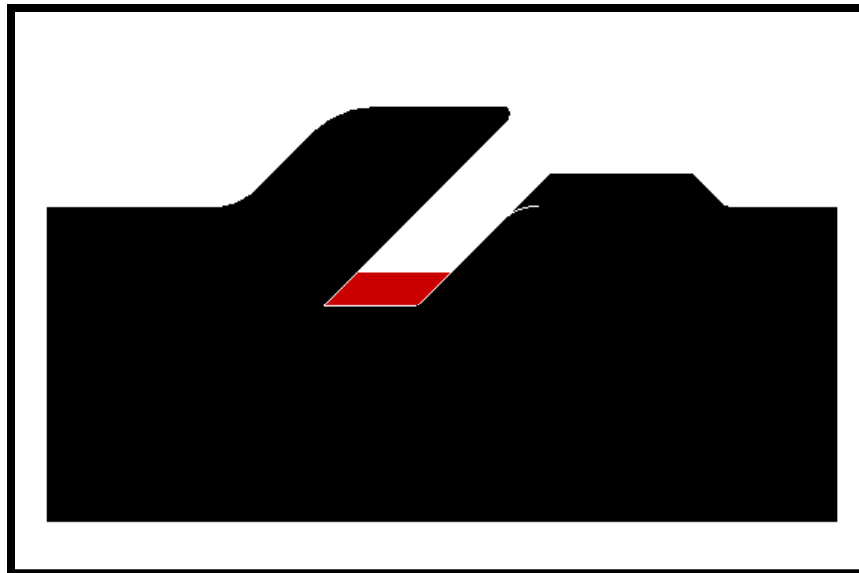

FINITE ELEMENT ANALYSIS

× Stress/Strain analysis

- + Determine if panels will introduce unwanted stresses in ring
- + Initial results suggest that material strength is not a concern

× Assumptions

- + Material is 4130 Steel
- + Left & Right boundaries are fixed
- + Uniform Distributed Load Applied to triangular tab
- + Simulates a binding or maximum loading situation

FINITE ELEMENT ANALYSIS

Surface: von Mises stress (N/m²) Surface Deformation: Displacement field (Material)

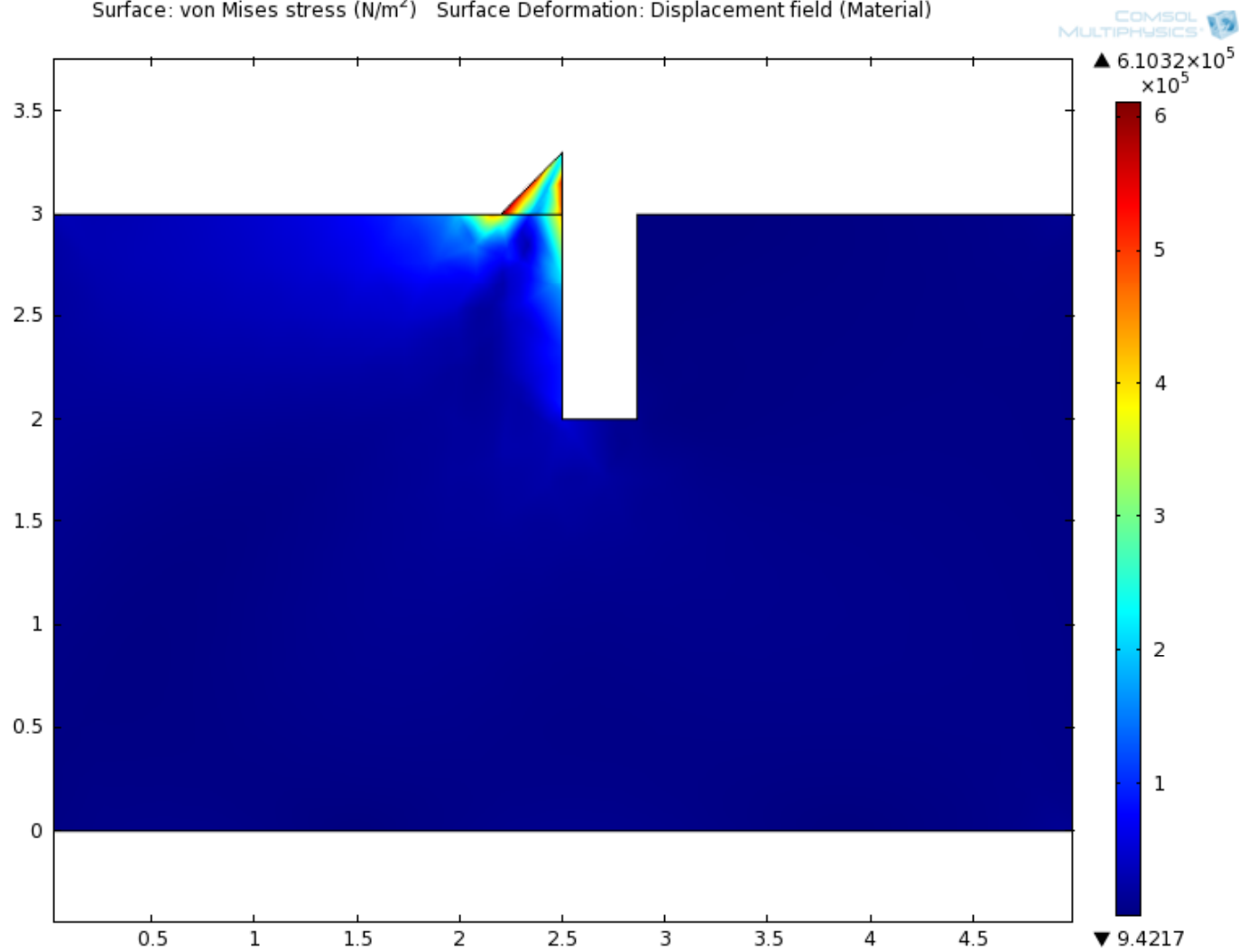

MATERIAL SELECTION

- ✘ Take all analysis into consideration when selecting a material
- ✘ Possible materials
 - + Aluminum (2024 or 6061)
 - + Stainless steel (302 or 304)
 - + Steel (4130)
- ✘ We will conduct further analysis of the system to select a final material

Questions or Comments?