

Design and Control of an Outdoor Robotic Walker

Senior Design Final Report – April 2012

By:

John Jaguszyn, Jonathan Lenoff, Michael Bunne

Department of Mechanical Engineering

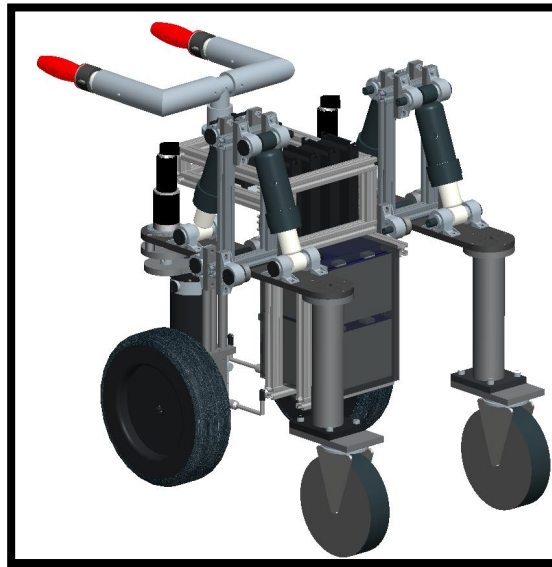

Project Sponsor

Dr. Emmanuel G. Collins, Ph.D – *Department of Mechanical Engineering*

CISCOR



Department of Mechanical Engineering
FAMU-FSU College of Engineering
2525 Pottsdamer St, Tallahassee, FL 32310

Abstract

The current generation of mobility assistive devices is limited in their versatility and ability to traverse a wide range of terrains. These limitations disallow many disabled and elderly individuals from freely traversing common everyday environments, such as grass, gravel, and lightly wooded areas, as these individuals rely on these devices for support and assistance. Therefore, there exists a need to provide a mobility assistive device capable of operating in a wide range of environments – both indoors and outdoors – and actively assisting the user in traversing typical everyday obstacles. This paper describes the process of designing and manufacturing the initial research platform that will lead to such a device.

The presented design will utilize an active control system based on intuitive user controls to drive the device and actively assist the user in safely traversing in real environments. The presented prototype acts as a foundation to this design by including the completed frame, handles, suspension, and driving mechanisms of a fully operational passive outdoor walker and incorporating all of the electronic components for the power and control systems necessary to implement the actively assistive design.

The presented design was developed to maximize the device's versatility, robustness, user-friendliness, and indoor/outdoor operation while minimizing cost and weight. The device was designed to support up to 300 pounds of loading, be able to overcome 4 inch obstacles, traverse freely over gradients of up to 10° on varied and uneven terrain at up to 3 mph, and operate in a semi-omni-directional manner capable of traversing 45° directly from the center axis. Additionally, the device was manufactured to resemble the current generation of walkers in both aesthetics and standards.

This paper describes the design and manufacturing process resulting in a prototype that meets or exceeds many of the aforementioned characteristics. The device measures 25 inches wide, 37 inches tall, and 27.5 inches long and is capable of supporting 100 pounds. It utilizes adjustable shocks in the suspension to compensate for any substantial changes of mass in the future and a plot mapping the appropriate adjustments to these shocks has been generated experimentally. Though the device does not provide semi-omni-directional motion, it incorporates a modular design allowing future work to easily expand the drive system to achieve this. The device is capable of

reaching speeds of 5 mph and was successfully tested on tile, carpet, cement, grass, and gravel. It provides basic protection to the fragile system components from standard environmental hazards through the use of polycarbonate plastic sheets. The device represents a substantial step towards empowering an entire population of currently disadvantaged people and was achieved successfully within the given budget of \$5000.

Table of Contents

Introduction.....	1
Concept Generation	11
Final Concept: Four-Wheeled Dual-Driven.....	36
Engineering Economics	42
Results and Discussion	43
Environment, Health and Safety	50
Conclusion	50
Acknowledgements.....	53
Appendix.....	54
Engineering Drawings	98
References.....	135
Member Biography	136

List of Figures

Figure #

PAGE #

1) Assistive Technology Devices.....	3
➤ Analyzes the various devices intended for physical empowerment	
2) Gantt Chart for entire Senior Design Project.....	10
➤ Summarizes project plan, detailing significant project dates	
3) Initial Design # 1.....	13
➤ 6 Wheel, Ackermann steering design	
4) Initial Design # 2.....	15
➤ Four Wheel, In-Line suspension design	
5) Initial Design # 3.....	17
➤ Reinforced 6 Wheel, Ackermann steering design	
6) Initial Design # 4.....	19
➤ Streamlined redesign of Initial Design # 2	
7) Initial Design # 5.....	21
➤ Rigid Skid Steering & Seat design	
8) Ackermann Steering.....	26
➤ CAD representation of Ackermann steering used in Initial Designs	
9) Front Axial Operation for Ackermann Steering.....	27
➤ Depicts the inherent function of Ackermann Steering	
10) Straight Ackermann Positioning.....	27
➤ Depicts symmetrical Ackermann steering	
11) In-Line Driving Shaft Arrangement.....	27
➤ Depicts Shaft Suspension for in-line steering	
12) Interim Design # 1.....	29
➤ 6 Wheel, In-Line suspension with squared frame	
13) Interim Design # 2.....	30
➤ 6 Wheel, In-Line suspension with Sway-Arm Caster redesign	
14) Interim Design # 3.....	31
➤ 4 Wheel, uniform suspension design	

15) Interim Design # 3.....	31
➤ <i>Interim Design # 3 with viewable (5'6) human scale</i>	
16) Picture of Driving Wheels.....	32
➤ <i>Picture of the two 12" air-filled tires, purchased off eBay</i>	
17) Offset Swivel Caster.....	33
➤ <i>Picture of McMaster Ezy-Roll Caster used in Final Design</i>	
18) Picture of Driving Motors.	33
➤ <i>Picture of the two 4600 RPM Motion Tech motors, purchased of eBay</i>	
19) Picture of Motor & 12" Tire Arrangement.....	34
➤ <i>Depicts motor/wheel assembly</i>	
20) Sway Arm Caster Design.....	34
➤ <i>Picture of caster shaft redesign used to absorb horizontal system loads</i>	
21) Air Shocks.....	35
➤ <i>Monroe MA-785 Max Air Shock used in Final Design</i>	
22) Driving Motor Shaft Arrangement.....	35
➤ <i>Singular Driving Stalk with driving motor offset</i>	
23) Completed Final Assembly.....	36
➤ <i>Picture of complete Final Assembly with all components</i>	
24) Finalized Singular Suspension Model.....	38
➤ <i>Picture of walker suspension – one side</i>	
25) 80/20 T-slotted Aluminum Framing.....	39
➤ <i>Picture of Aluminum framing used in Final Design</i>	
26) Compression Fit 80/20 Slot.....	40
➤ <i>Flange Nut forced frictional compression fit for 80/20 Alum</i>	
27) Dimensioned Handle Assembly.....	40
➤ <i>Shows the adjustable handle heights</i>	
28) Dimensioned Caster Wheel.....	41
➤ <i>Shows dimensions of Caster Wheel & Shaft</i>	
29) Singular Driving Wheel.....	41
➤ <i>Shows the Driving Wheel Assembly</i>	

30) Thrust Bearing.....	42
➤ <i>Indicates Location of Thrust Bearing on Connector Plate</i>	
31) Driving Motor & Encoder Testing.....	43
➤ <i>Shows the experimental setup for testing driving motors & encoders</i>	
32) Monroe Air Shock Testing.....	44
➤ <i>Shows the experimental setup for test Monroe MA785 Air Shocks</i>	
33) Air Shock Compression vs. psi loading plot.....	45
➤ <i>Plot comparing load vs. shock compression with varying psi</i>	
34) Potentiometer Testing.....	45
➤ <i>Shows the experimental setup for the Linear Potentiometers</i>	
35) Potentiometer Resistance vs. Displacement plot.....	46
36) Driving Shaft Alighting.....	47
➤ <i>Shows a reasonable alignment of Steering Motors & Driving Wheels</i>	
37) Picture Progression of self powering walker.....	48
➤ <i>Indicates walker can operate with no needed force input</i>	
38) Various Terrain Testing.....	49
➤ <i>Indicates the walker successfully operating on varying terrains</i>	
• (a) Gravel	
• (b) Cement	
• (c) Grass	
• (d) Tile	
39) Complete Final Assembly.....	55
➤ <i>Real Time Image of Completed Final Assembly</i>	

List of Tables

Table #

PAGE #

<i>1) QFD with House of Quality for entire Senior Design Project.....</i>	<i>7</i>
➤ <i>Compares quantifiable project requirements vs. consumer demands</i>	
<i>2) Design Criteria Comparison.....</i>	<i>23</i>
➤ <i>Comparison of Design Criteria</i>	
<i>3) Calibrated Criteria Weight.....</i>	<i>23</i>
➤ <i>Predicts Respective Design Criteria Weightings</i>	
<i>4) Initial Design Decision Matrix.....</i>	<i>24</i>
➤ <i>Weighted Decision Matrix used to rank Initial Design</i>	

(1.0) Introduction

(1.1) Introduction to the project

The current generation of available assistive walking devices is limited in their functionality and traversable terrain. Many of these devices are manufactured solely for indoor operation and offer little assistance to the user beyond passive structural support. Those individuals who require assistance in walking and wish to travel outdoors can be deterred by the smallest of hazards such as grass, gravel, or uneven terrain. For many individuals, scooters or electric wheelchairs are unnecessary or too expensive for their needs and unfortunately offer limited safety and control. To further empower the disabled and elderly community, a new class of automated assistive devices needs to be developed. This project aims to create the initial research platform for an eventual semi-omni-directional outdoor robotic walker to meet this need.

As this project is in its first year, the primary focus of this paper is the design and construction of the first prototype. This prototype was designed and manufactured to meet certain specifications from our sponsor and is a unique design – not relying on any previous research platform as a template. The ultimate goal of this project is to empower the disabled and elderly population with increased outdoor mobility by creating a robotic walker that provides basic stability and is capable of semi-omni-directional motion to assist in a non-restrictive manner.

(1.2) Needs Assessment

The purpose of this project was to design and fabricate a highly stable, semi-omni-directional robotic walker. The walker was required operate on varying grades and multi-terrain surfaces, while being able to withstand typical environmental hazards. The prototype was designed to maintain current walker dimensions and standards, operate within the standards of the Americans with Disabilities Act (ADA), and increase the safety and mobility of the user. The walker will eventually utilize an integrated control scheme to actively assist user mobility through user force inputs.

Needs Statement

The primary objectives of this project are the design and fabrication of a highly stable semi-omni-directional robotic walker to be used in both indoor and outdoor environments, with the ultimate goal of empowering the disabled and elderly population by increasing mobility beyond the standards currently achievable with present day walking assistive devices.

(1.3) Problem Description

With an ever-increasing life expectancy, there remains a growing reliance on assistive devices for the elderly and disabled population. Out of an estimated 13.1 million users of assistive technology devices (Kraus, Gilmartin 1996), users needing mobility assistance accounted for 61.8% of this population. Mobility assistance has traditionally been accomplished through the use of canes, walking sticks, passive walkers and active/passive wheelchairs. Of these devices, walkers rank as the second most used mobility assistive device only behind walking sticks and canes. An estimated 21% of the mobility disabled users of assistive devices use a walker.

A powered wheelchair offers the most assistance as it requires limited to no dexterity or muscle strength above the waist. However, these devices are both large and expensive, thus making them difficult to obtain and use freely. An unpowered wheelchair offers less assistance as it requires both dexterity and arm strength to operate. A passive walker offers comparably less help as it requires both the strength and balance for an individual to stand upright combined with the strength to operate the walker and potentially brace oneself for a fall. A cane is arguably the hardest to use, as there is typically only one contact point with the ground and strength and dexterity is needed in the body as a whole. However, a cane represents arguably the easiest assistive technology to use because it is light weight and has a small footprint

As depicted in the Figure 1, the use of assistive technology devices increase with age, rising from about one million for 24 years old and under to around four million for people 75 and over. Studying the trend line for walkers in the figure reveals that the number of users doubles between 65 and 75 years of age. Because of the large and growing number of people already using standard walkers, the presented device must be aesthetically and functionally similar to the basic walkers so that users will not feel

intimidated or overwhelmed when transitioning to a more high-tech device.

Currently, there exists no commercially available walker capable of effectively traversing in both indoor and outdoor environments to assist an individual seeking increased mobility but does not necessarily have the strength and dexterity to operate a device passively. This problem creates a demographic for which the presented design platform will be administered; subsequently improving their quality of life through engineering innovation.

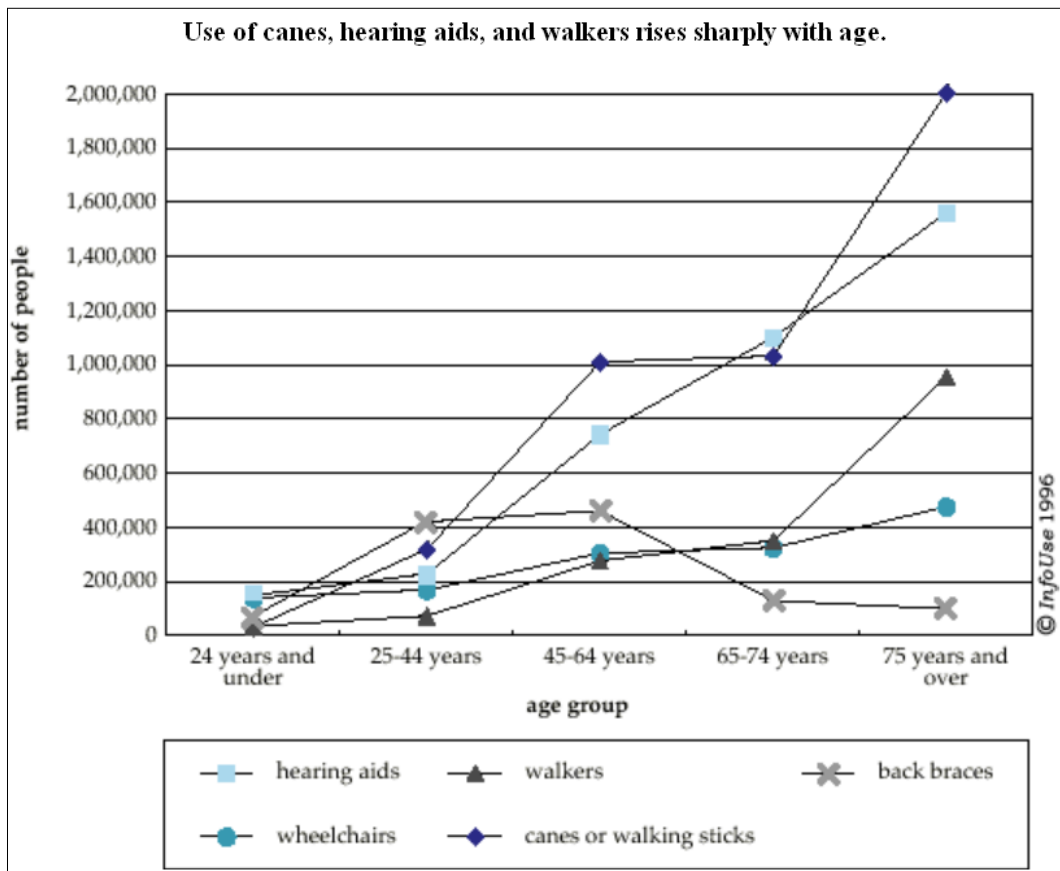

Figure 1: Assistive technology devices (Survey from 1990)

With this in mind, the presented device was designed to not only offer increased stability, but also to function in an outdoor environment where the user will be uninterrupted by certain ambient conditions. The walker was designed to assist the user through standard mobility maneuvers and executions. For example, the user may need to translate in a 45 degree direction in a slanted/off-center fashion for the purpose of intent, or perhaps travel on sloped ground or varying terrain. For such tasks, the user will be able to interact with the control system and command the walker to act intuitively and sufficiently to support and assist the user in executing these maneuvers. The controls were designed to be housed within the walker itself, allowing the device to operate free of tether.

(1.3)1. Goal Statement

The goal of this project is to assist the disabled and elderly community in their efforts for increased outdoor mobility through the application of fundamental engineering knowledge and practical life experiences to ultimately create a functional outdoor semi-omni-directional robotic walker.

(1.3)2. List of Objectives

1. Function within ADA standard environments
2. Support up to 300 lbs of loading
3. Maintain typical walker dimensions
 - a. Handle height between 32 and 39 in
 - b. Handle width between 14 and 23 in
 - c. Handle depth between 8 and 14 in
4. Traverse over 4" obstacle
5. Move up/down a slope of up to 10 degrees
6. Traverse 45 degrees from center axis
7. Max operating speed of 5 MPH
8. Operate continuously for up to ½ hour
9. Traverse varied terrain
 - a. Tile, carpet, cement, grass, dirt, gravel, sand
10. Modular design

(1.3)3. Testing Environment for the Objectives

1. Design walker components to meet listed ADA requirements
2. Laboratory tests involving incrementally loading the walker up to 300 lbs and observe signs of fatigue and/or failure.
3. Design walker components to match typical walker dimensions.
4. Field test walker with various real-world obstacles (roadside curb, roots etc...).
5. Laboratory test using pitch meter to verify the ability of the walker to traverse varying grades
6. Laboratory tests using motion capture to measure the angle of motion capable by the walker
7. Laboratory tests involving motion capture to calculate walker speed
8. Determine current draw of system and extrapolate to estimate life based on power system capabilities
9. Field tests of walker on various terrains
10. Design components of walker to account for potential future modifications

(1.3)4. List of Constraints

1. \$5000
2. Less than 200 pounds
3. Force-based user input
4. Meet ADA requirements for indoor operation (width less than 32 inch)

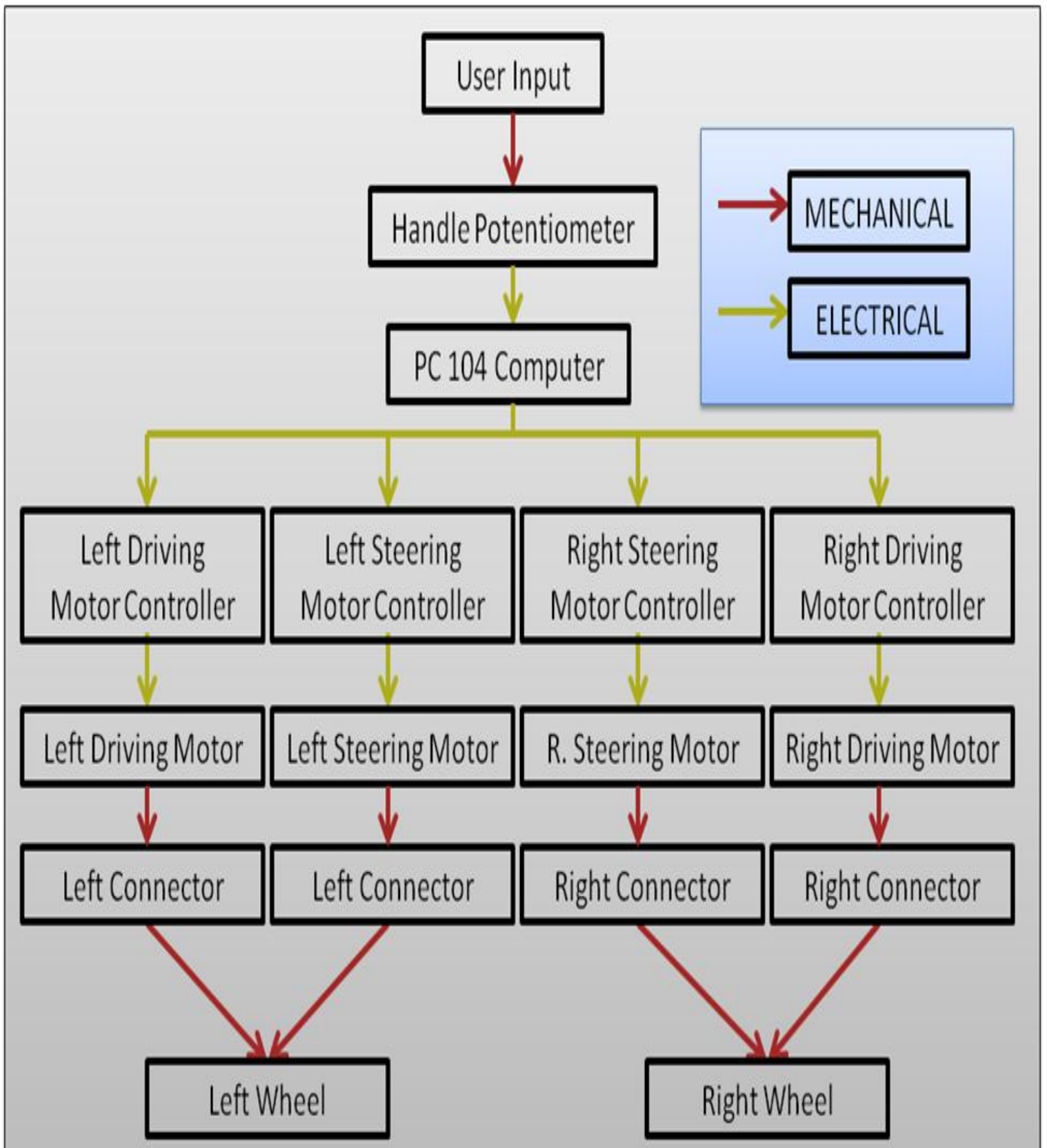
(1.4) Functional Diagram

(1.5) Quality Function Deployment

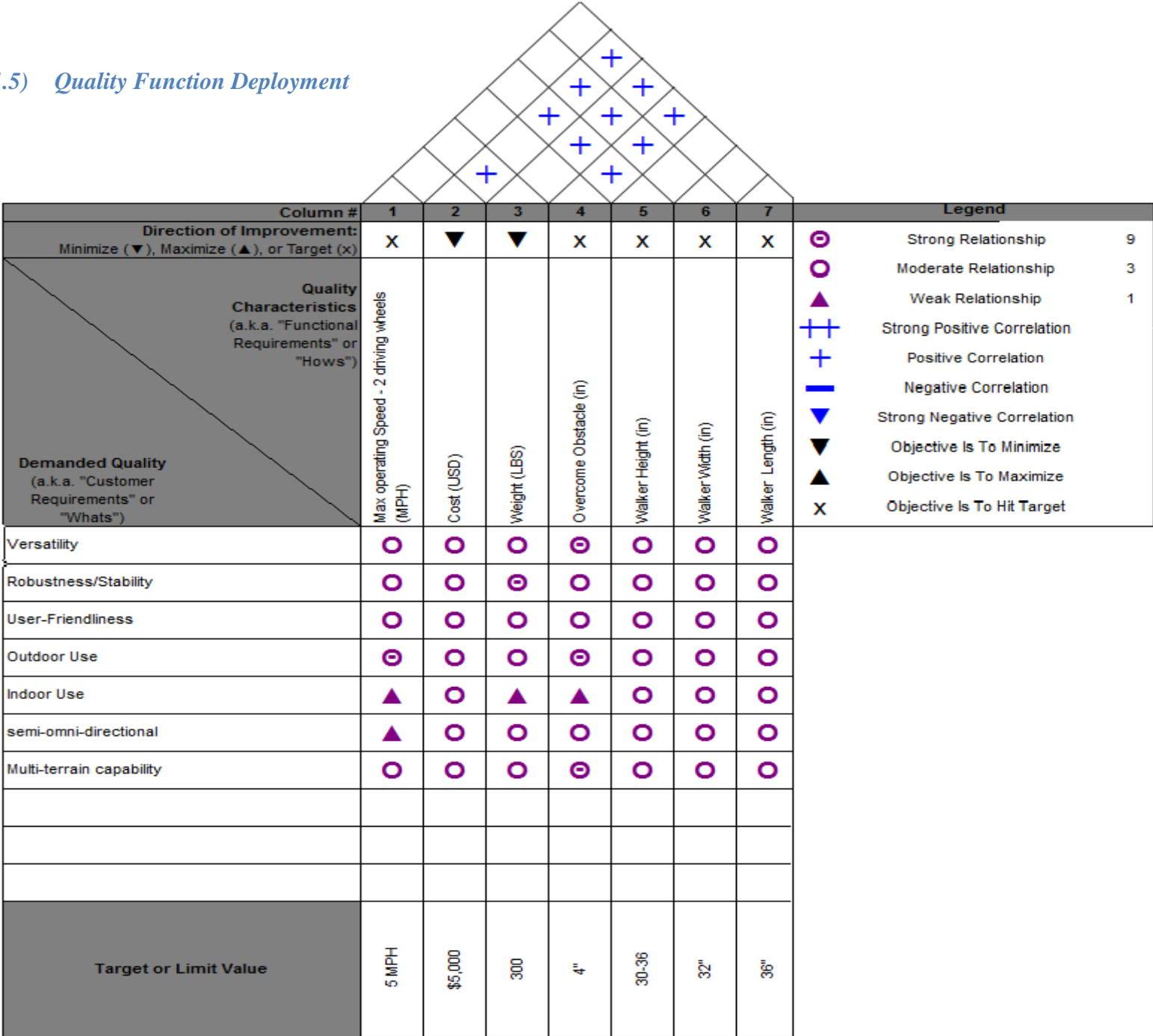

Table 1: QFD with House of Quality

(1.6) Project Plan

This project followed a four-stage process to successfully meet the demands of the sponsor: design, manufacture, controls, and amendment.

Design

The design stage entailed meeting with the sponsor to determine the design requirements, performing extensive research on the current field of comparable products to determine basic standards and benchmarks, and compiling this information into a single cohesive design that is congruent with the needs of the sponsor. Majority of the design process took place in the Fall semester, however continued system adjustments and debugging required suitable redesigns to our prototype in Spring, for the purpose of manufacturing a suitable research platform.

Manufacturing

Manufacturing required ordering and machining the necessary components and assembling the components to create the prototype. Manufacturing began at the end of Fall and continued throughout the Spring. Machine shop delays and late part ordering contributed to the relatively limited testing phase of the project, and this led to a somewhat simultaneous Testing phase. The Amend/Rebuild part of the design is still being completed because of these delays.

Testing

During the manufacturing phase, individual components of the device were tested as they were constructed to verify their performance and make modifications as needed. However, the majority of the testing took place once manufacturing and assembly of the entire system was completed. Most objectives were measureable benchmarks that could be evaluated in a laboratory setting. Some objectives, however, could only be measured in the field, as the walker was intended for real world application. Both kinds of tests were documented with pictures and / or video to provide documentation for future reference. Tests were repeated as throughout the amendment and redesign phases as new components were designed and constructed.

Amend/Rebuild

The final stage required redesigning of any catastrophic failures and rebuilding or modifying any lesser failures or inefficiencies discovered through testing the prototype. As mentioned above, these build steps are dependent on one another and due to the delays incurred in manufacturing, the amend/rebuild stage is currently still being completed. Beyond the expected amendments, the walker may still require modifications based on unforeseen dilemmas encountered later in the process.

(1.6)1. Gantt Chart

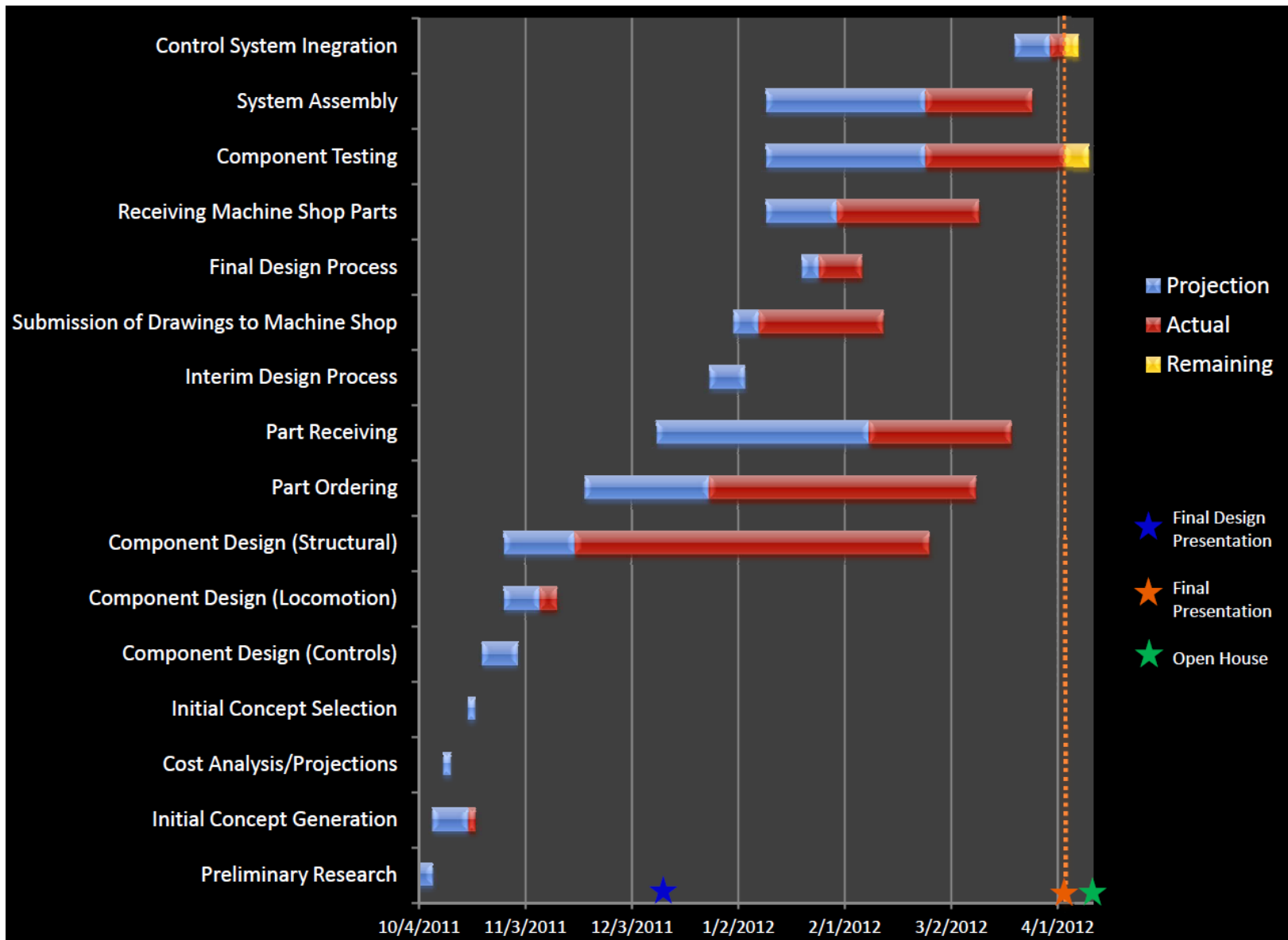

Figure 2: Gantt chart for Entire Project

(2.0) Concept Generation

(2.1) *Initial Conceptual Designs*

Before an initial generation of design, certain quantifiable specifications were made for the frame, propulsion system, and control logic alike. The frame was required to be able to support up to 300 pounds while maintaining currently generation walker aesthetic. The walker was limited in width because it was to be able to move through a 32 inch wide door (ADA standard) with ease. To satisfy the objective of traversing four inch obstacles, the driving wheels were specified to have a minimum diameter of 12 inches to allow the walker to traverse over various terrains, slopes of up to +/- 10°, and over 4 inch obstacles. The caster wheels were not limited in size, though larger wheels were preferred. As previously mentioned, the walker was designed to be able to translate up to 45 degrees from a central axis at a max operating speed of 3 mph. Quantifying any control logic is a parameter that was not critical for this project, but does give a standard for the prototype to meet once submitted for further research. Proposed control system for the walker were sit-down/stand-up assistance, object detection/avoidance, fall prevention, and walking gait localization & navigation.

(2.1)1. Concept 1

Concept one combined some of the best aspects from several of the initial designs; however, since it is not tailored to any one objective, it certainly lacks specialty skills. Concept one was sturdy and balanced with six wheels and allowed for small payload capacity; however the six casters made true omni-directional movement quite difficult. This design did, however, allow ample space for electronics and included such features as fall detection, stand-up assistance, and object avoidance. The six wheel design could maintain a more level relation with the ground while traversing difficult terrain. The single steering motor made the control algorithms simpler as it limited some superfluous degrees of freedom; however, Ackerman steering yielded limited steering motion. Both wheels were required to turn on common pivots preset during construction thus disallowing the dynamic adaption of suspension to any terrain irregularities. The single motor steering also necessitated a very strong motor to turn both wheels.

Concept one was designed to be controlled by the user interacting with a force plate. The force plate resolved the forces and associated torques in all axes. The advantage of this was that there were very few moving parts required in the control input system (handles) and that the control algorithm could adjust steering properties on the fly. The disadvantage of the force plate was the cost and limited force capability. The force plate would not have been able to take the full force of a human falling and there would have had to have been additional hardware to limit the force input to the force sensor. All control devices would have had the ability to be passively adjusted by the user. This required less hardware and complex controls however did necessitate that the user have the strength and dexterity to operate the adjustments. The six wheel design allowed for one or possibly even two casters to fail and still have an operable device. The air-filled tires allowed for additional shock absorption while also allowing for varying traction performances based on the average psi of the tires. Air-filled tires were also widely available and simple to implement; however, they were more likely to fail. Punctures or broken valves could render the tires useless, potentially disabling the system if this were to occur on a driving wheel.

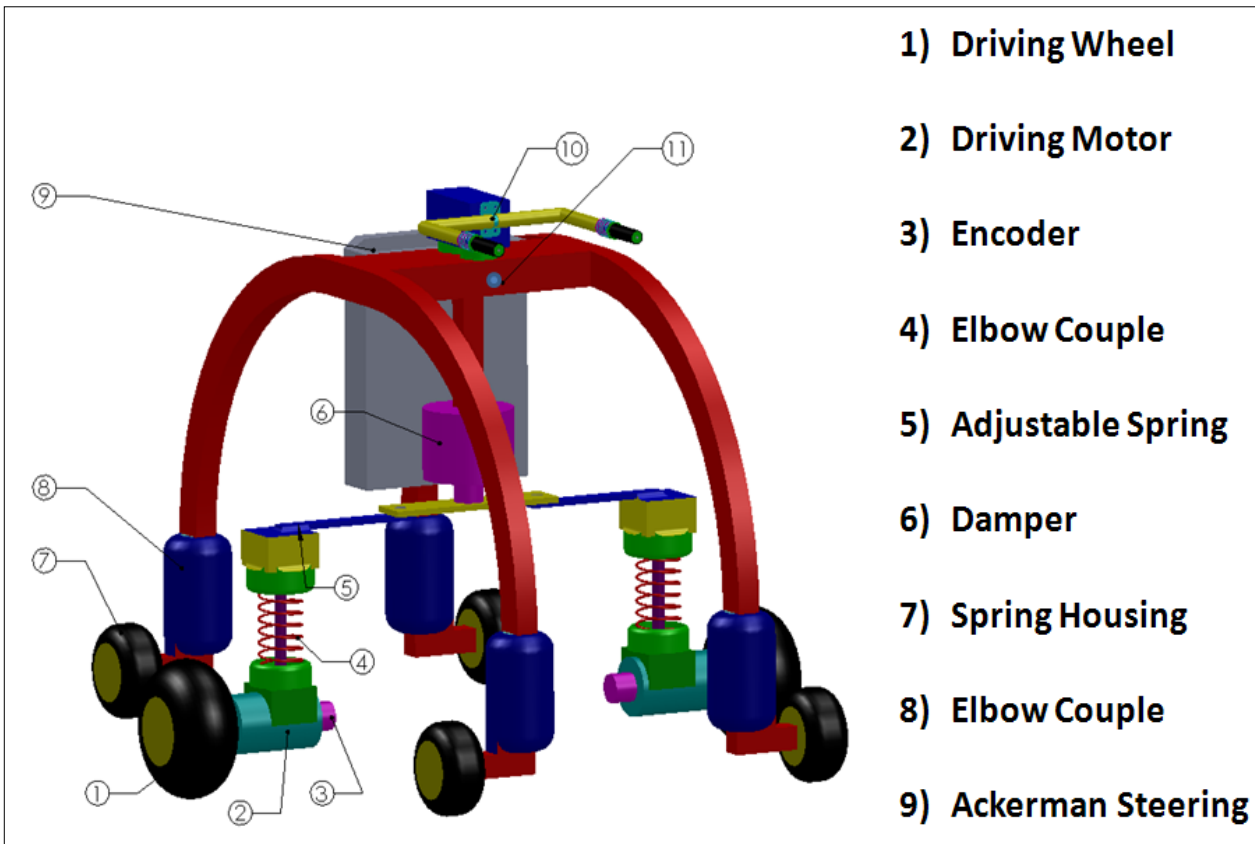

Figure 3: Concept One Design

Pros:

- 1) Sturdy, well balanced and robust
- 2) Ample space for electronics
- 3) Common Implementation of steering and driving motors
- 4) Dynamically adjustable control input with force plate
- 5) Good Outdoor Operation and Traversability

Cons:

- 1) Limited steering capabilities
- 2) Fragile Tires
- 3) Large/Heavy Structure
- 4) Unusual Foreign Walker
- 5) High Cost

(2.1)2. Concept 2

Concept two most resembled a typical walker. This concept offered the best versatility coupled with the one of the highest degrees of user friendliness. One of the distinct advantages of this design was the truly omni-directional steering. Each steering motor, paired with a driving motor, was fully capable of spinning the driving wheel 360°. This could provide true holographic movement to the walker. Another design feature was the puncture-less tires. The tires implemented on this concept were to be honey-combed to provide additional suspension and resistance to puncture. The control for this design was to utilize a spring driven system with two linear potentiometers. The displacement of the springs on the handle caused by the natural walking motion of the user would have correlated to a displacement in the potentiometer and thus an input to the system. These controls provided a cheap and stable platform for the user to interact with the system. The passive suspension and dimension adjustment also helped to lower costs while providing additional robustness.

The necessity for an additional steering motor and thus additional motor controller would certainly have increased cost and also made the controls more complicated. Due to the full rotation of the driving wheel, more expensive encoders, absolute encoders, were required to provide an absolute position as opposed to a position relative to the initial orientation. This concept provided for fall detection, stand-up assistance and object avoidance which made this design very user-friendly.

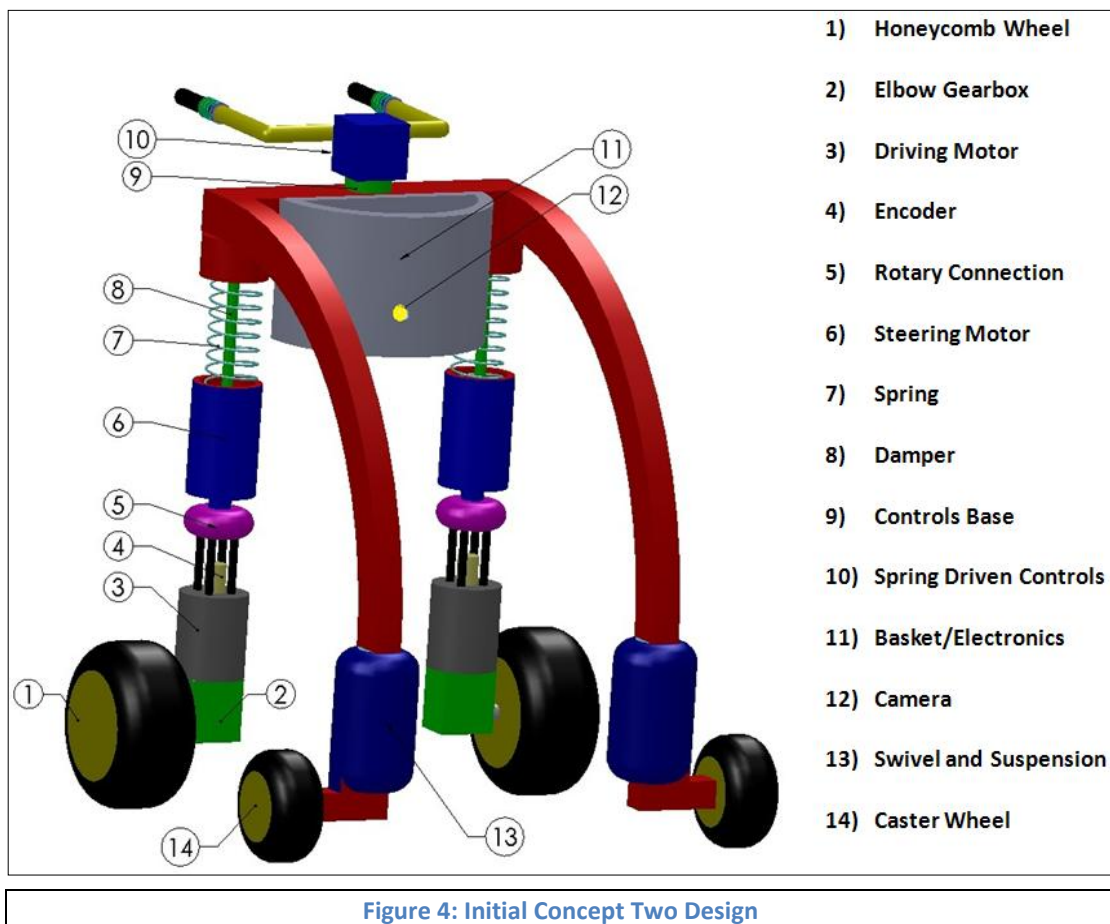
Pros:

- 1) Familiar walker design
- 2) True omni-directional movement
- 3) Cheap, sturdy controls
- 4) Puncture-less tires
- 5) Excellent versatility
- 6) Extremely user-friendly

Cons:

- 1) Single tire failure could render walker useless
- 2) Less stable if one was to fall backwards
- 3) Limited space for electronics
- 4) Limited payload capacity
- 5) Additional motor and electronics required
- 6) Expensive and hard to implement

(2.1)3. Concept 3

Concept three was designed primarily to support and assist the user in carrying a heavy payload, and implemented a reinforced frame that exhibited a variety of advanced technical features. In order to better distribute large loads and effectively reinforce the frame, steel crossbeams were added in a crossing manner. For complete support, this design utilized six caster wheels (two driving and four passive). Durability was increased with the number of casters, considering the possibility of one or more casters breaking or malfunctioning. However, this design was still built to be semi-omni-directional. The walker would have contained three motors (with encoders): one for steering, and one for each driving wheel. This design would have also featured a set of seven lasers mounted in multiple critical positions on the walker to guide the user safely and efficiently around certain terrains. A sensor would have been mounted at each crossbeam intersection, as well as on each back and front leg of the walker, with one in the middle of the walker, facing the user. Two sets of sensors, three in the middle and two in back, were intended to detect and implement the stand-up and fall/slip prevention systems, and two sensors in the front allowed a 180° peripheral viewing range to make the concept capable of object avoidance. A computer system would have interpreted the laser data and provided the logic to flag decision markers as a basis for action.

An active suspension system would have been used to counteract the effects of the walkers bulky size and weight- namely to keep the sensors as level and properly calibrated as possible. Active suspension also improved the quality in handling the walker. All of the necessary electrical components and computer systems were to be housed and mounted in safe and accessible location on the walker. A storage space (bin) for personal items or belongings would also have been mounted onto the frame. Ackerman steering was to be utilized in this concept, where the radius of curvature of the front wheels would fall in a line that is perpendicular to the rear wheels. This steering system corrected the problem of slippage during the execution of a turn; however, this design offered limited indoor use due to its bulky dimensions and caster placement. The cost was also predicted to be relatively high due to the additional material proposed, and due to these costs, as well as the cost of advanced technical features and systems implemented within this design, the practicality of this design was lowered.

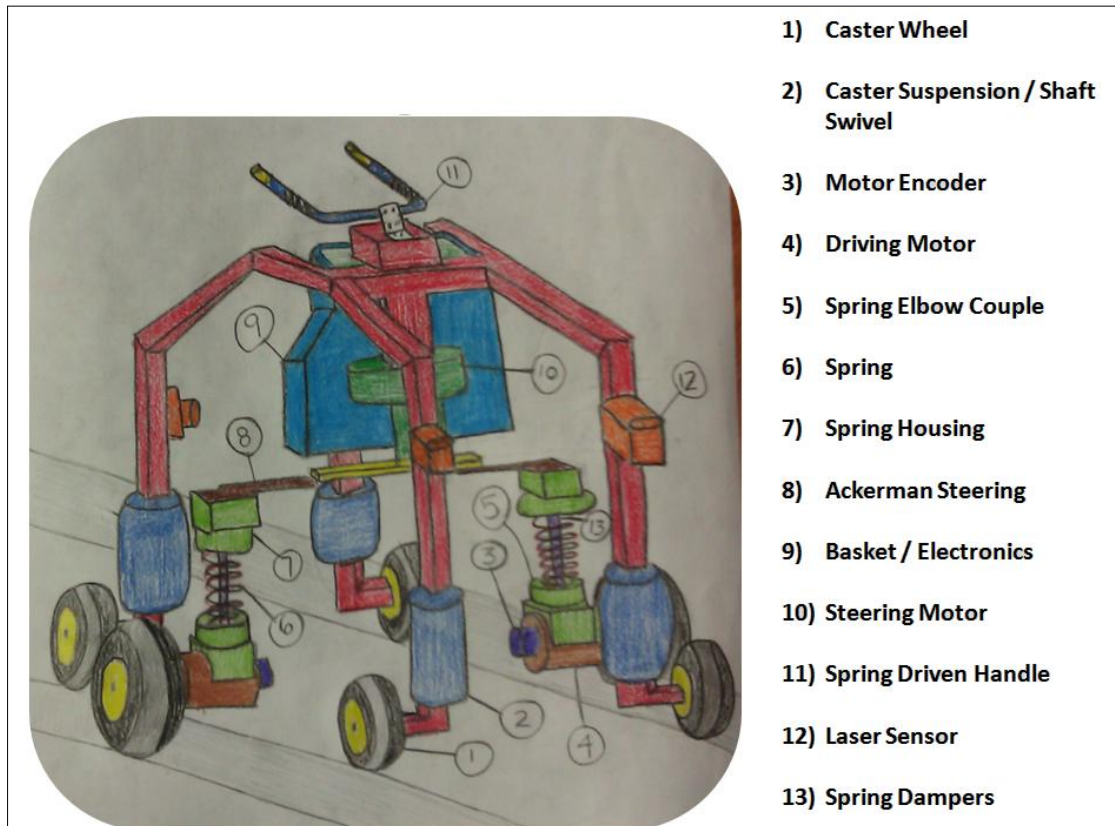

Figure 5: Concept Three Design

Pros:

- 1) Designed for heavy payloads
- 2) Durable, solid frame with added supports
- 3) Good Outdoor use (increased access & mobility with object avoidance system)
- 4) Active Suspension
- 5) Intelligence Systems
 - Laser guided fall/slip assistance & stand-up assistance
 - Basic laser guided object avoidance

Cons:

- 1) Bulky Frame (limited indoor use)
- 2) Fragile Tires
- 3) Heavy structure
- 4) High cost
- 5) User transitional ease

(2.1)4. Concept 4

Concept four was one of the more advanced walker designs. It was designed for increased speeds with better access/mobility characteristics. This walker had many profound features, namely the laser sensor technology. Fall detection, stand-up assistance and object avoidance technology were all made available through the implementation of laser sensors. However, the walker's passive suspension system could have lead to detrimental system damage.

This walker had four omni-directional wheels, which allowed the walker a true omni-directional range of motion. With an initial goal of speed and versatility in mind, two driving motors (with encoders) would have powered all four wheels, while one motor powered the steering. The walker would have been composed of a light yet durable material able to withstand any system shock. Disregarding the cost of extraction and purification, a Titanium frame would have made the walker very lightweight while not sacrificing any structural integrity. Titanium is a low density, highly-ductile material with a relatively high melting point and fairly low thermal conductivity. All these characteristics made titanium an excellent candidate for this speedy lightweight walker model.

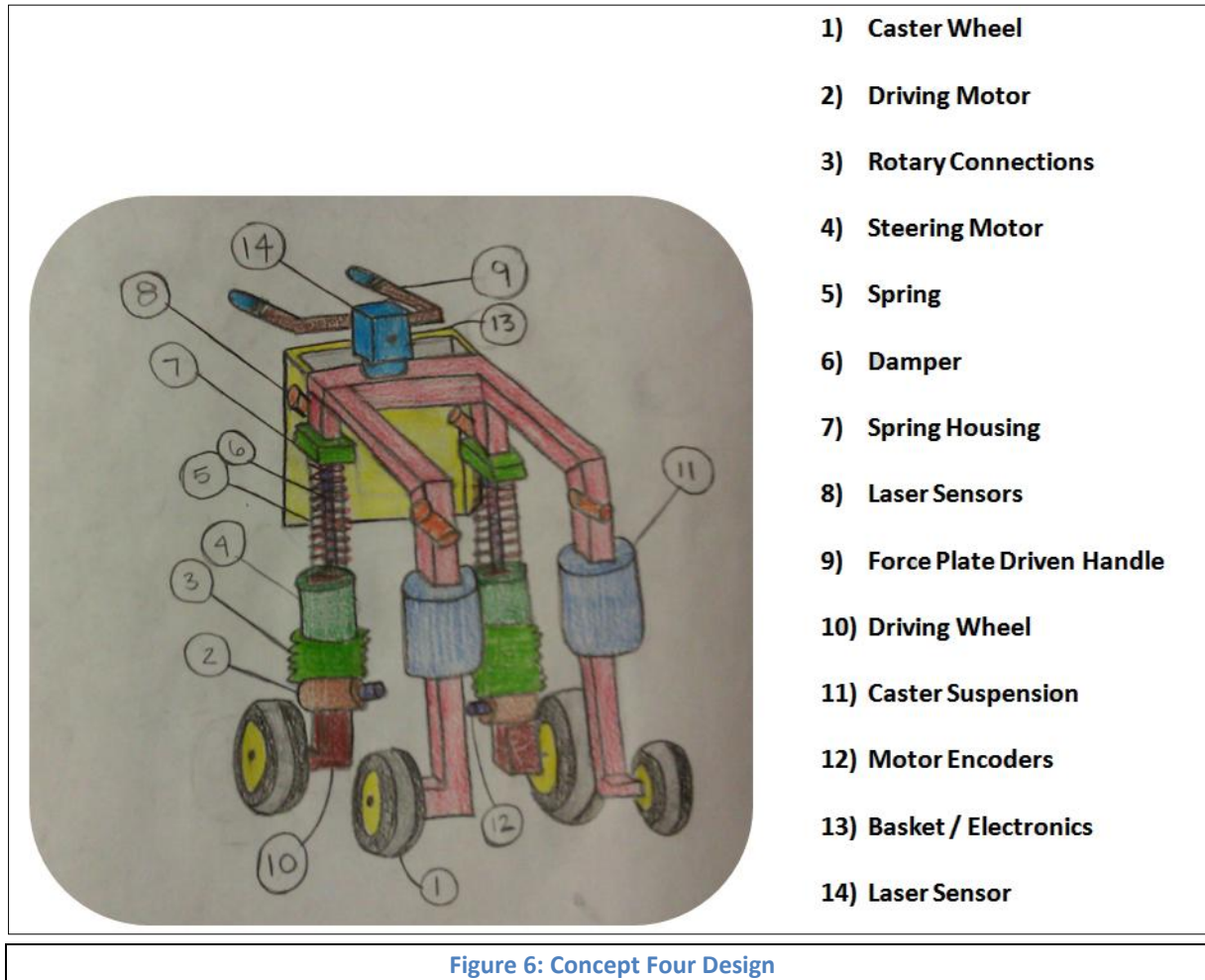

Figure 6: Concept Four Design

Pros:

- 1) Fast, lightweight walker design
- 2) Semi omni-directional navigation
- 3) Force Plate Recognition System
- 4) High Indoor Use
- 5) Object Avoidance, Fall detection, Stand-up assistance

Cons:

- 1) Limited Payload Capacity
- 2) Fragile components (Force Plate)
- 3) Limited Outdoor use
- 4) Limited payload capacity
- 5) Low Demand for speedy walker, expensive start-up
- 6) Slightly less durable and resilient compared to other designs

(2.1)5. Concept 5

This concept focused on the device's ability to traverse the widest range of terrain possible. The most substantial difference between this design and other concepts involved the driving mechanism. As seen in Figure 7, wheels were replaced by treads to allow the device to traverse through sand, mud, and snow. These treads were driven by a single large driving motor and utilized a skid steering system. This resulted in semi-omni-directional capabilities. In addition to the fall prevention and stand-up/sit-down assisting features discussed in previous designs, this concept featured a front-mounted laser for object detection and avoidance and included a fold-down chair for riding if the terrain became too difficult for walking. To compensate for the potential of added weight from a rider and for the largely unstable terrains this device was designed to traverse, an active suspension system was to be implemented. The dimension adjustments were limited and passive due to sizeable hardware, but a large basket was to provide substantial payload capacity.

By implementing a hybrid walking-riding operation scheme, this device allowed the user to traverse easily across both standard and treacherous outdoor terrain. However, because of the bulky nature of the treads and large supportive structure, the device would not have been very applicable for indoor operation. In addition, the treads and active suspension system would have increased costs and the extra hardware would have substantially increased the weight. Because of the additional support, however, the device was expected to be fairly robust.

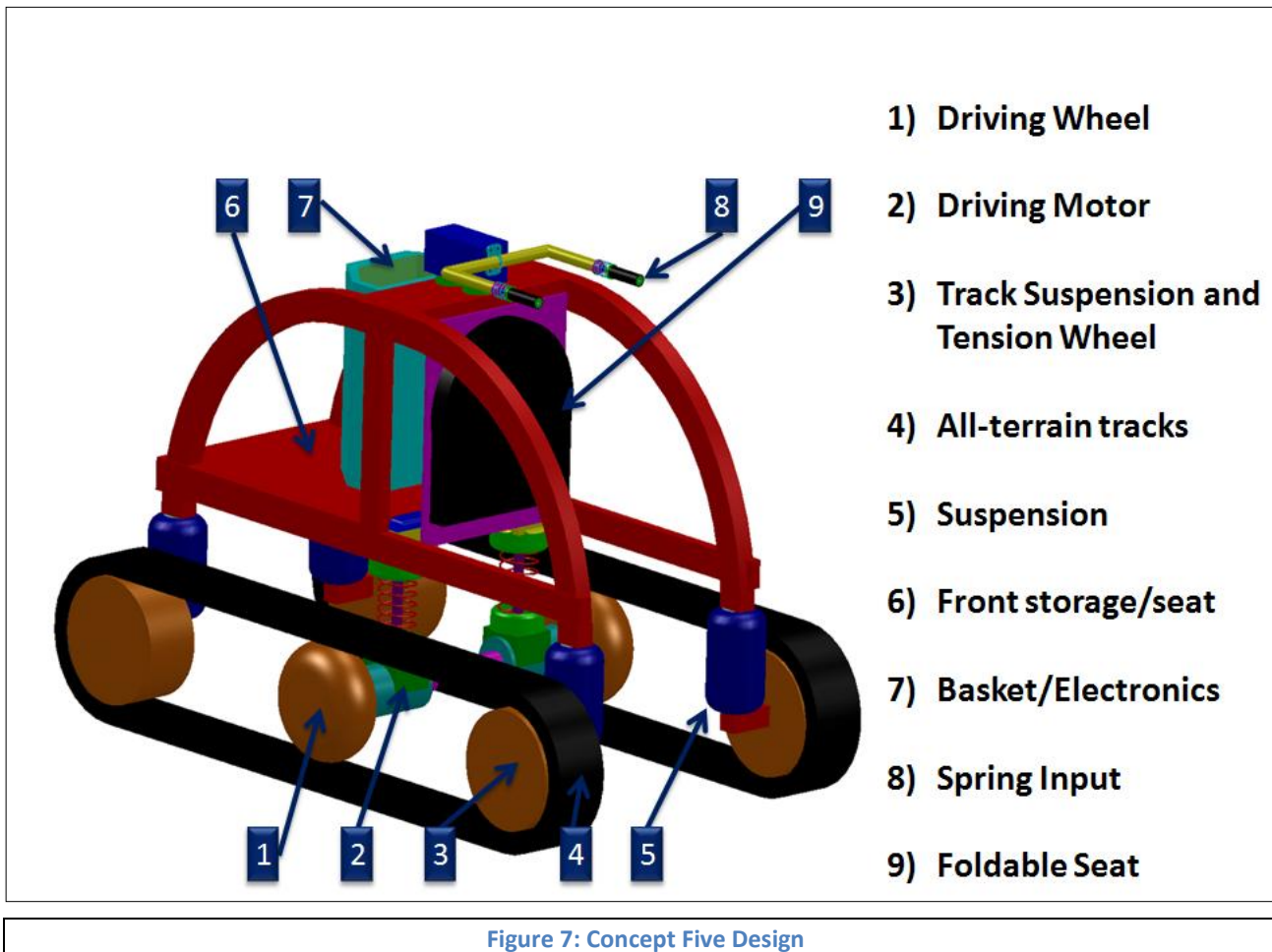

Pros:

- 1) Great Outdoor Operation
- 2) Active Suspension
- 3) Riding Capability
- 4) Large Payload

Cons:

- 1) Minimal Indoor Operation
- 2) Passive Dimension Adjustments
- 3) Expensive
- 4) Heavy

(2.2) Selection Criterion

With 5 different initial conceptual designs and a set of objectives to satisfy, a set of selection design criteria were generated to adequately deduce the quality of each design. Below is a ranked list of 7 selection criterion that was derived from customer needs and sponsors request.

- Versatility: The device's ability to perform numerous functions in multiple environments and account for many user body types. This takes into account the control and function capabilities, the estimated traversibility, and the dimensional adjustment capabilities. (Overall weighting 15%)
- Robustness: The device's overall ability to not break. Examines number of complex mechanism and their resistance to failure. (Overall weighting 17.5%)
- User-Friendliness: The ease to which an individual can become acclimated to the different device functions as well as the cosmetic appeal. (Overall weighting 22.5%)
- Indoor Operation: The device's ability to operate indoors in a safe and efficient fashion. Turning radius and overall size are important considerations. (Overall weighting 14.5%)
- Outdoor Operation: The device's ability to operate outdoors in a safe and efficient fashion. Suspension, traction, driving power and steering mechanism are considered. (Overall weighting 23%)
- Cost: Both the initial investment necessary as well any foreseeable maintenance issues are compared. Low scoring options are very costly. (Overall weighting 4%)
- Weight: The overall size and weight of the device is taken into consideration and the requirements to move/support that structure. High weights scored low values. (Overall weighting 3.5%)

The charts, shown in Tables 2 and 3, summarize the process taken in accurately determining specific criterion weights. Because a heavy emphasis was placed on designing a device capable of both indoor *and* outdoor operation, outdoor operation ranked as the most important criterion at 23%, whereas the weight and cost of our system are much less significant.

5	Greatly more important		Versatility	Robustness	User-friendliness	Cost	Indoor	Outdoor	Weight
4	Substantially more important	Versatility	1.00	3.00	0.50	4.00	0.33	0.25	5.00
3	Somewhat more important	Robustness	0.33	1.00	0.50	4.00	3.00	1.00	5.00
2	Slightly more important	User-friendliness	2.00	2.00	1.00	5.00	2.00	1.00	5.00
1	Same importance	Cost	0.25	0.25	0.20	1.00	0.25	0.20	2.00
1/2	Slightly less important	Indoor	3.00	0.33	0.50	4.00	1.00	0.50	4.00
1/3	Somewhat less important	Outdoor	4.00	1.00	1.00	5.00	2.00	1.00	5.00
1/4	Substantially less important	Weight	0.20	0.20	0.20	0.50	0.25	0.20	1.00
1/5	Greatly less important	Sum:	10.78	7.78	3.90	23.50	8.83	4.15	27.00

Table 2: Criteria Comparison

	Versatility	Robustness	User-friendliness	Cost	Indoor	Outdoor	Weight	Average
Versatility	0.09	0.39	0.13	0.17	0.04	0.06	0.19	0.15
Robustness	0.03	0.13	0.13	0.17	0.34	0.24	0.19	0.17
User-friendliness	0.19	0.26	0.26	0.21	0.23	0.24	0.19	0.22
Cost	0.02	0.03	0.05	0.04	0.03	0.05	0.07	0.04
Indoor	0.28	0.04	0.13	0.17	0.11	0.12	0.15	0.14
Outdoor	0.37	0.13	0.26	0.21	0.23	0.24	0.19	0.23
Weight	0.02	0.03	0.05	0.02	0.03	0.05	0.04	0.03

Table 3: Calibrated Criteria Weight & Predicted Averages

Table 4 summarizes the ranking and selection process performed for the various walker concepts. As seen below, each design was assigned a score based on the previously mentioned criteria and put into the decision matrix. This table shows the criteria, their respective weights, and each concept's score based on an absolute scale (1 being lowest, 5 being highest) and a weighted scale. The summations of these values represent the weighted average score for each design with the highest ranking three highlighted in the table. As shown in Table 1, Concept 2 scored the highest with Concepts 1 and 5 following. Concepts 1 and 2 represented moderate to good scoring designs in relation to all presented criteria, whereas Concept 5 represented an optimization of the highest weighted criterion. These concepts warranted further detailed evaluations to determine the final design

	Concept 1		Concept 2		Concept 3		Concept 4		Concept 5		
	Weight	Score	Weighted	Score	Weighted	Score	Weighted	Score	Weighted	Score	Weighted
Versatility	0.15	3	0.454	5	0.757	3	0.454	3	0.454	3	0.454
Robustness	0.175	4	0.699	3	0.524	5	0.874	3	0.524	4	0.699
User-friendliness	0.22	3	0.670	4	0.894	2	0.447	5	1.117	3	0.670
Cost	0.04	2	0.086	2	0.086	1	0.043	1	0.043	1	0.043
Indoor	0.145	3	0.429	3	0.429	2	0.286	3	0.429	1	0.143
Outdoor	0.235	4	0.926	3	0.695	3	0.695	2	0.463	5	1.158
Weight	0.035	2	0.066	3	0.099	1	0.033	4	0.132	1	0.033
Sum:			3.331		3.483		2.832		3.163		3.200

Table 4: Weighted Decision Matrix

Evaluation of Initial Concepts

All previous data and designs were collectively analyzed to determine the components necessary for an effective design of the walker. Three broad design aspects were developed to properly evaluate the walker's components: locomotion, steering and controls. By researching each of these parameters and incorporating the most effective method of each into a collective design, a concept that was more cohesive was able to be developed. This is important as each section is dependent on one other. In the following section each design criterion is discussed in detail and its importance is determined for consideration in the first interim design.

Locomotion

The wheels of a robot are the foundation on which the implementation of the system will be driven. The presented walker is designed to exhibit smooth, semi-omni-directional movement 45° relative to the central axis. The wheels and frame were to employ a passive suspension system to reduce system shock and increase durability. To successfully empower the disabled and elderly community in their efforts for increased outdoor mobility, the device must maintain user safety and health. With that in mind, the device must be designed to employ a locomotion method for ultimate stability and rigidity when operating outdoors. In addition, this outdoor operation required accounting for a wide range of terrains and weather conditions. Therefore, a dependable, rigid, and versatile wheel type was to be properly selected.

In initial concept # 1, the six wheel arrangement was effective but can increase system weight and cause subsequent hazards from potential material failure. Initial concept # 2 had a smaller, four wheel frame. Along with reducing system weight, the user was less restricted by the inherent geometry of the structure. However, using four wheels presented a potential problem with system stability in the event of a fall. Initial concept # 5 offered outstanding stability, but using treads to propel the walker through skid steering was not only expensive, but would have definitely caused the system to exceed the weight limit and would not have allowed the system to successfully operate indoors. Considering all three design benefits and flaws, a six wheel design was chosen as ideal to meet the design requirements.

One of the most critical components of the walker is the type of suspension intended for use. The walker was required to traverse natural outdoor obstacles while maintaining safe and consistent operation. Proper suspension selection was crucial in the design of the walker, thus making it critical to perform a detailed analysis for an ideal shock/damper arrangement.

Steering

Figure 8 shows a CAD drawing demonstrating an Ackerman steering assembly. Commonly used in automobiles, Ackerman steering solves the problem of the systems wheels turning at different radii. Invented by German Carriage Builder George Lankensperger and later

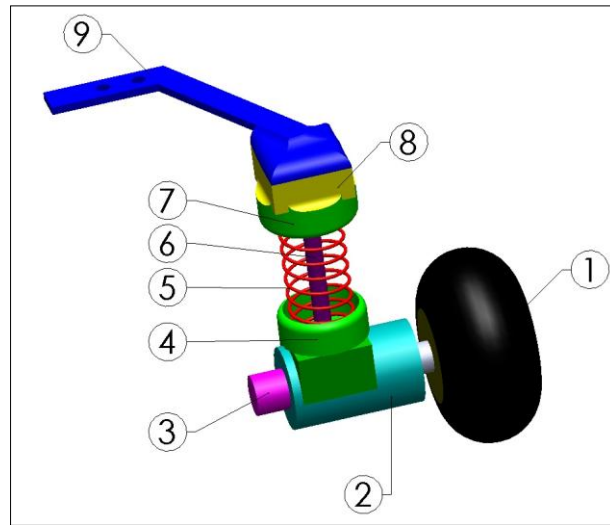

Figure 8: Ackermann Steering used in Initial Designs

patented by his agent, Rudolph Ackermann, this steering technique was originally implemented for drawn carriages. To avoid the effects of sliding or skidding, Lankensperger determined that would be best accomplished by having each separate axle arranged around the radii of a circle, sharing a common point. Figures 9 and 10 depict the function of Ackermann steering, where the tire arrangement is symmetrical, allowing the “vehicle” to make smoother, skid/slip-free turns. However, it is important to note that rather than having all of the tires turn about a common point, Ackerman steering distributes the most effective pivoting technique evenly about the contact point. In other words, each wheel obtains its own pivot, slightly offset from the hub. Unfortunately, the implementation of Ackermann steering onto the presented device would have occupied a considerable amount of usable storage space for essential electronic components. Also, Ackermann steering restricted the objective to translate in a semi-omni-directional motion, deeming this steering technique inadequate for the project.

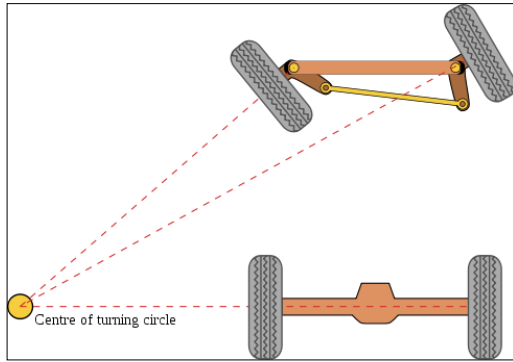

Figure 9: Front Axel Operation (A.S.)

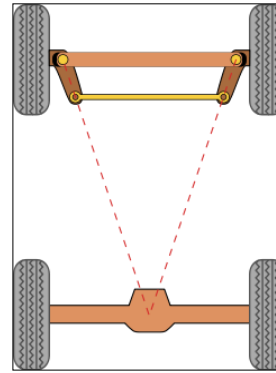

Figure 10: Straight Ackerman Positioning

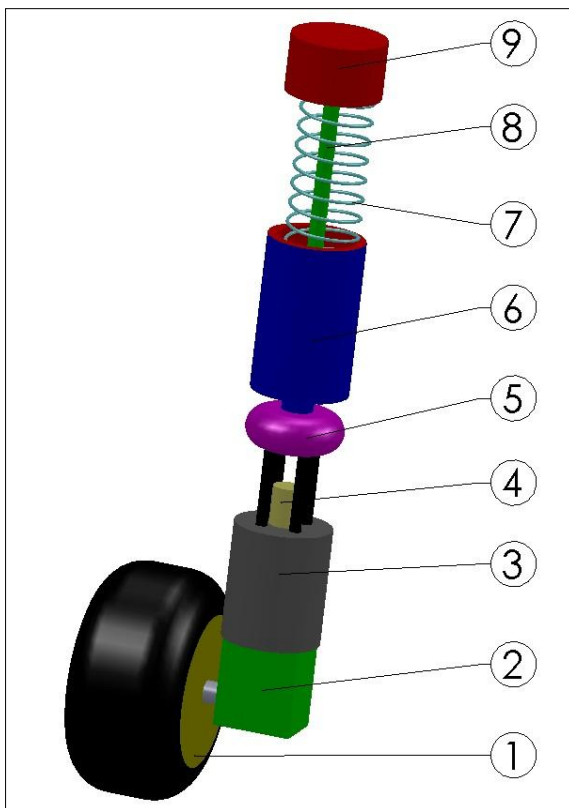

Figure 11: Driving Motor/In-line Steering

Figure 11 shows a CAD drawing of an in-line driving shaft, extracted from initial concept # 2. As can be seen in the figure, the steering and driving motor are placed in line with each other, with the wheel being offset from this axis. After further research, it was discovered that it is more effective to have the wheel line up with the driving motor, forcing the steering motor to fall off that axis, existing externally; thus requiring a redesign of this driving leg. This was done to allow the wheel to turn and propel the wheelchair about any 45° angle and also to reduce the contact patch with the ground, thus reducing friction. This was an effective steering technique in application as it offered a compact way to

drive the walker while offering a passive suspension system. However, in the application of this steering method, additional designing was required to account for any lateral, horizontal or line of motion load incident on the leg.

The final steering scheme to be analyzed was skid steering. As seen in initial design # 5, skid steering implemented tread to propel the walker in a desired direction.

Although very effective, this steering technique was very expensive and presented a potential safety hazard to the operator as its cumbersome geometry and crude locomotion can endanger the user.

From this analysis, it was determined that in-line steering would be the most effective and safe way to direct the walker.

Controls

The control scheme implemented in the walker will determine how different hardware will interact both with the environment and the user. The control structure will be based on a real time, computer based system used to accurately calculate the position, velocity and acceleration of the wheels as well as apply the necessary torque outputs.

Two different force-input systems were considered for the walker. The first was a KISTLER force plate. This plate was used to measure reaction forces generated by a body interacting with the plate to quantify balance, walking gait, and other parameters of biomechanics. Although this plate interprets force based on six axes, the maximum allowable force input is not suitable for the system requirements. Additionally, the force plate was significantly complex, exceeded the allowable budget, and the solid state electronics may have been damaged from overuse. For these reasons, the KISTLER force plate was deemed unsuitable for the design. The other control scheme considered for the design was a spring-driven control handle. This handle utilized linear potentiometers to interpret user force input based off of the displacement within the potentiometer. Along with being much more cost effective, these handles presented a simplified solution to interpret and calibrate necessary motor responses. However, these handles only predicted motion based on two axes, compared to the KISTLER's six. For these reasons, it was determined that the spring driven control scheme would be used in the design.

(2.3) *Interim Design*

(2.3)1. *Interim Design # 1*

Depicted in Figure 12 is the interim design #1. This design was an amalgamation of initial concepts 1, 2, and 5. As seen in the figure, this design used six wheels: two middle driving with four passive caster wheels for structural support. Using in-line suspension and implementing a steering motor offset will the walker was expected to perform favorably in a variety of environments. However, there were a few problems with this design. Its bulky aesthetic and crude directives would have restricted the user's walking gait as the back casters impeded their movement. This was especially true considering the caster swiveled around the leg and could have potentially hit the user. Also, any lateral and longitudinal forces incident on walker were unaccounted for, as there was no suspension to counter-act such horizontal loads. These design imperfections were corrected in the next design, interim design #2.

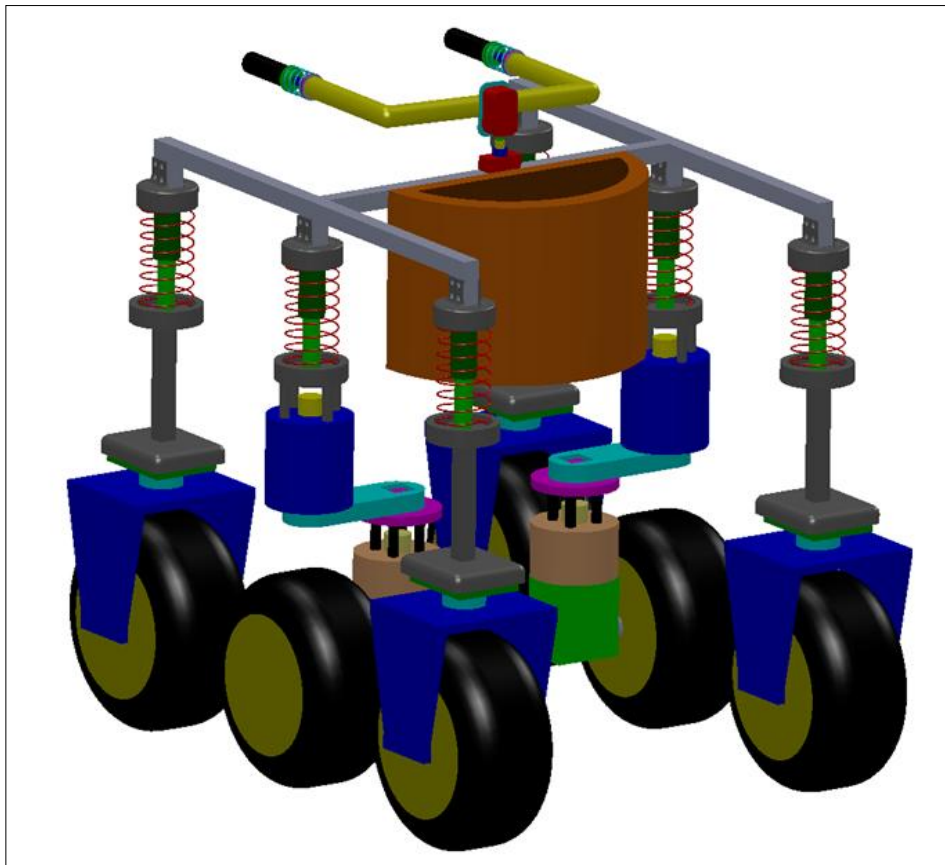

Figure 12: Interim Design # 1

(2.3)2. Interim Design # 2

In interim design #1, six wheels were used to provide supreme system stability. In-line suspension was also used to reduce system shock and improve the quality of operation for the user. However, as previously mentioned, a few design imperfections existed in the interim design #1. For the second interim design, various solutions to account for the faults in the first design were investigated.

Interim design #2 can be seen in Figure 13, and the necessary modifications can be clearly seen. To account for any longitudinal load incident on the walker, all caster shafts were modified to implement a sway-arm swivel caster, forcing the walker's inherent geometry to absorb such loads. In doing so, additional space was created to increase operable room for the user. It can be seen from the figure that there were still some flaws within this system. Interim design # 2 experienced a similar shock problem with the middle driving shafts, and correcting the problem in the casters was determined to not be sufficient for the entire system. Also, lateral loads imposed on the walker would cause the driving shafts to cripple inward and the caster shafts to fracture at the sway juncture, as there was no support for such forces.

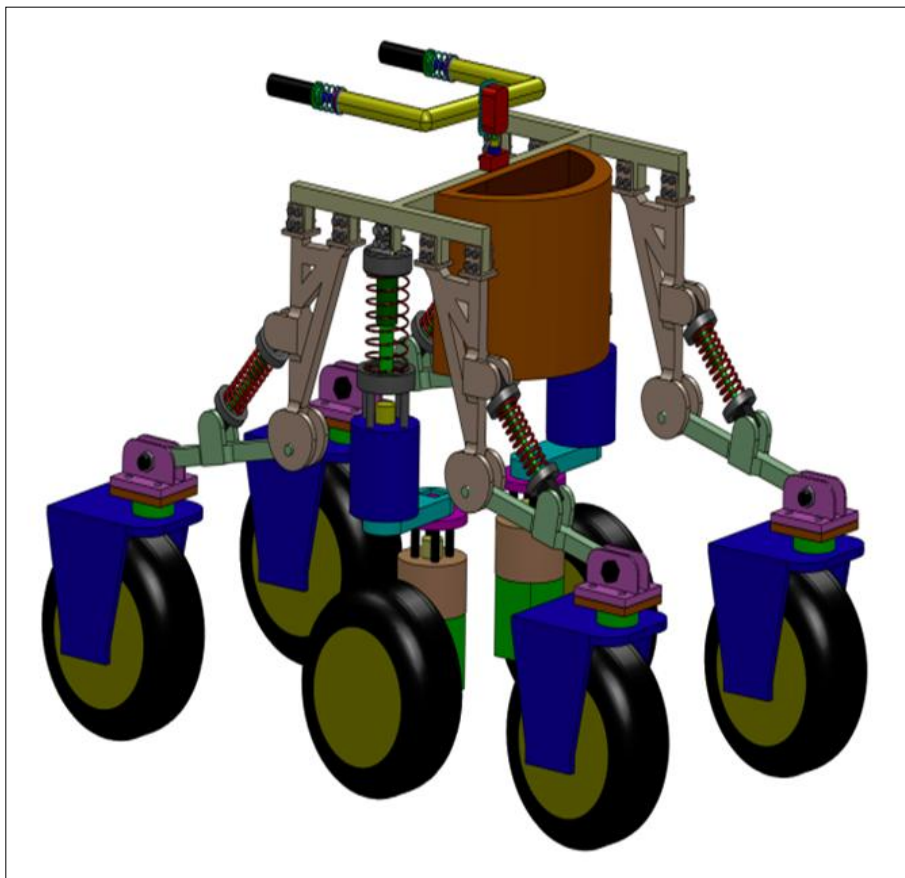

Figure 13: Interim Design # 2

(2.3)3. Interim Design #3

The final interim design was derived from the previous concepts and takes steps towards simplifying and streamlining the design. Shown in Figure 14, the final design for interim design #3 incorporated a similar suspension layout and utilized the same control scheme, but shifted the device from a six-wheeled design back to a four-wheeled design. The frame was also adjusted to compensate for lateral loading and overall walker stability, implementing uniform suspension with additional framing support. This design exhibited a more symmetric and sound geometry, compared to our previous designs

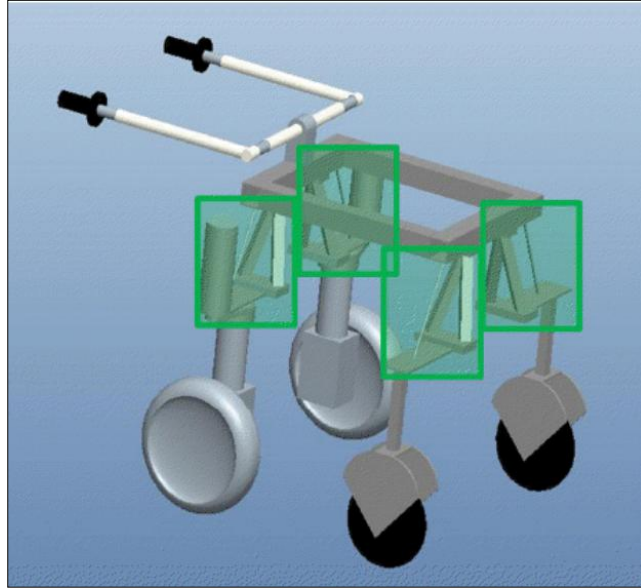

Figure 14: Interim Design #3 (uniform suspension)

which presented multiple sources of error and increased the overall instability.



Figure 15: Interim Design # 3

Additional modifications were made to the driving wheel assembly and supporting frame to account for available material, safety concerns, and the inclusion of the power and control systems. Interim design #3 also considered the space requirement for the necessary electronics and batteries, which would exist in the middle of the walker, ideally localizing the walker's center of mass.

Despite these improvements, there were still obvious design flaws to be addressed. Figure 14 shows the new suspension and how it has been offset by 90°. With

this, any load felt by the walker in the line of motion will attenuate this design. Also, using 2x2 inch core aluminum framing was unwise as alternative material was provided and offered substantial construction and budgetary advantages.

All of the aforementioned analysis was collectively considered for the final design. In order to choose the best synthesis of the above components, extended research and customer / sponsor considerations were applied to create the ultimate design. Consistent contact was maintained to the customer and advisors to improve the quality of the final design.

(2.4) Component Selection & Selection Process for Design Criterion

In this section, each design criterion will be discussed, elaborating more specifically on the thought process of our design criterion selection and subsequent walker improvements. Detailed market research and design analysis will be performed to allow progression in the design process. At the conclusion of this section, we will have standardized the criterion of our walker and established specific component selection.

Locomotion

Fitting the walker with appropriate tires was important, as all varied terrains will directly affect system performance. It was determined that honeycomb tires were not suitable for the walker due to the excessive cost and limited hazards the device is expected to encounter. Treads were also deemed too impractical and expensive for the design. The 12 inch air-filled tires were chosen as they met the requirements of the design along with being the most cost efficient and readily available. For wheel and walker strength purposes, our group confirmed the selection of 12 inch



Figure 16: Two 12" Metal Rim Tires (purchased off eBay)



Figure 17:McMaster Ezy-Roll Caster

diameter tires with metal rims to structural support. Pictured above are the two air-filled tires, purchased from eBay.

For the caster wheels a suitable 8 inch swivel caster from McMaster was selected. Composed of corrosion-resistant zinc-plated steel, these rubber *Ezy-Roll* caster & wheel can support up to 550 pounds using double ball

swivel bearings. The non-marking curved tread of the caster reduce the coefficient of friction and allow the wheels to roll

and swivel with ease.

Conveniently, two 4600 RPM, 320 Watt, 3.5 A_{max} Motion Tech motors were sold in combination with the 12 inch tires purchased off eBay, providing us with ample power for our walker. In order to use these motors, motor encoders had to be mounted. This required the removal of the pre-installed brake. The arrangement of the motors and wheels can be seen below.



Figure 18: 4600 RPM Motion Tech Motors



Figure 19: Motion Tech motors and tires

As previously mentioned, proper selection of the walker suspension was critical, as it serves as the primary source of system response and calibration. Determination of a general spring constant came from various shock analysis iterations in simulation. Using Working Model allowed the performance of an ideal shock to be simulated, and it was discovered that certain constraints arise in application. The shock must sufficiently support the walker and exhibit an ideal

displacement in operation.

Abiding to the project budget, the Monroe MA-785 Max-Air Shocks were selected for our walker's shock/damper system because they were both adjustable and readily available. Commonly used in automobiles, the Max-Air shocks more than satisfy the suspension requirement. Considering the pneumatic property of these air shocks, the application of such shocks must be executed by either preloading them or using an on-board compressor to gauge and calibrate an ideal psi. For the project and for the purpose of simplicity, the shocks will be preloaded to a predetermined psi.

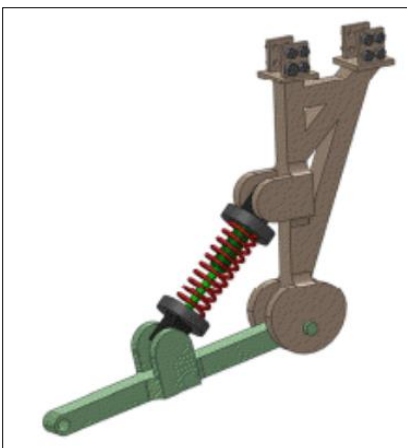

Figure 20: Sway-Arm Caster Design

After determining a suitable suspension for the walker, redesigns can be made to the frame to account for exterior forces felt by the walker. To account for longitudinal incidence, a caster shaft sway-arm redesign was made. In this, any loads felt from the front or back of the walker will affect the sway-arm and cause the load to absorb within the mid-mounted shock. This is an effective way to reduce axial loads within the walker, but

however, does not account for lateral forces employed on the system.



Figure 21: Monroe MA-785 Max-Air Shocks

Steering

3 different steering techniques were previously discussed, namely Ackermann steering, individual steering and skid steering. Skid steering can be considered the least suitable steering technique for the design, as it would not only be costly, but would disallow the group in meeting many project requirements (i.e. holographic movement, modular design, weight, cost etc...) and present a potential danger to the user. As instructed by our Faculty Mentor, the walker design should exhibit a modular transitional capability. With this, the walker design should essentially be able to be modulated from a six wheel (four caster, two driving) walker into a four wheel (four driving), lightweight walker. Considering this modularity requirement, implementing Ackermann steering will prevent any form of system transformations.

However, applying the individual steering technique not only allows the walker to modulate between shaft arrangements, but also grants more versatility in the core arrangement of parts and features.

Vertical individual steering will be implemented in the walker, with the wheel and steering motor aligned on the same axis, forcing the driving motor to exist outside of this arrangement.

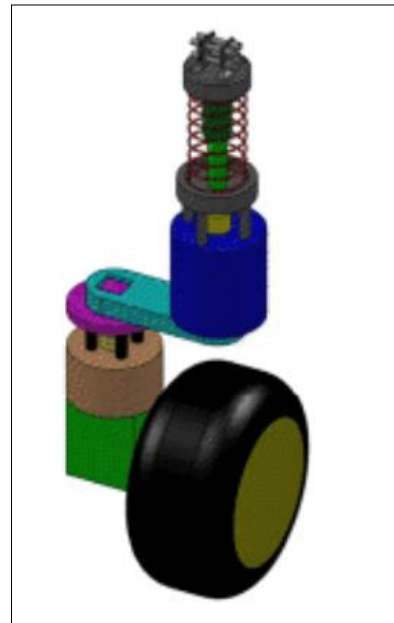

Figure 22: Singular Driving Stalk with driving motor offset

Controls

To avoid confusion within the walker, a bridge between physical human inputs and proportional walker responses must exist. The KISTLER force plate allows a maximum input force of roughly 5 pound, while the spring-driven handle offers a maximum input force of about 500 pounds. The force plate can interpret up to six different input axes, compared to the two axis capability of the spring-driven handle. Although the spring handle does have moving parts, its overall complexity and cost make it a suitable candidate for our walker design. In terms of breakable parts, the handle proposes a greater threat. However, replacing parts for a self-fabricated handle will be significantly cheaper than fixing a complex and expensive force plate. Both of the proposed force recognition modes offer an input monitoring feature, but a closer look at each individual system will bring forth the undeniable favoring of the spring-driven handle.

(3.0) Final Concept: Four-Wheeled Dual-Driven

The final design makes substantial adjustments to the previous concept to simplify the control scheme, improve the suspension performance, and finalize material specifications and the structural supports. Shown in Figure 26, the final design makes room to include the PC104 computer stack and motor drivers. This design also incorporates a suspension layout similar to our

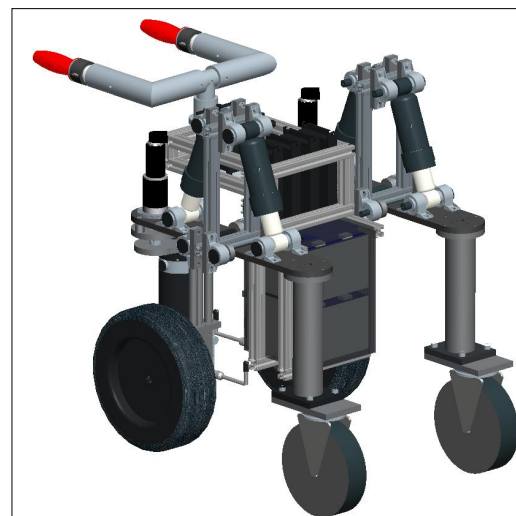

Figure 23: Completed Final Assembly

second interim concepts, where the spring acts at an angle with the direction of travel. The

material used and the geometry of the frame were modified to reduce weight and include a housing for the power and control systems. The handles were redesigned to be more robust and easier to adjust and the connection mechanisms for both the driving and castor wheels were finalized. The following sections describe in detail the various system components utilized in the final design.

Control System

The final design relies on the use of the computer stack to take analog inputs from the potentiometers and convert them using built in analog to digital converters so the computer can read the position of the potentiometer. After this input is placed through control algorithms designed for safe operation, a desired motor speed is fed to the motor drivers through the use of timers to create PWM (pulse width modulation) signals for the motor drivers. These PWM signals allow digital computers to emulate the analog signals necessary to control the motors. These motor controllers drive four independent brushed motors – two salvaged from a used electric wheelchair to propel the system (driving motors), and two high torque RE-max Maxon motors for rear-wheeled steering (steering motors). Linear potentiometers will act with springs mounted in the handles to translate the forces naturally given by the user through walking into proportional voltage controls for the driving and steering motors. That is, if the motor can accept a maximum of 24 volts, a potentiometer that is displaced half of its total value would result in the motor only allowed 12 volts. The control scheme will allow for both forward and backward movement to be registered independently from both hands, thus allowing the device to move freely at the user's discretion. The system is powered by two 12V lead acid batteries chosen for their relative inexpensiveness, availability, and safety. Though these batteries are heavier than possible alternatives, however, by placing them low on the device, the center of gravity is also lowered to increase stability. With these batteries, the system should be able to perform constantly under heavy (stall torque) loading for over a half-hour.

Because the aim of this project was to develop and construct the hardware for an initial research platform, the control system in our prototype is minimal. The device is currently only capable of moving forward and backward with force-based controls and power steering to be achieved in subsequent research. However, the device is fully wired, capable of housing all the necessary electronic components, and allows easy access to these components so that the control scheme, already being developed, can easily be implemented onto the device. This process will likely take place over the coming months by members of the CISCOR Lab.

Suspension

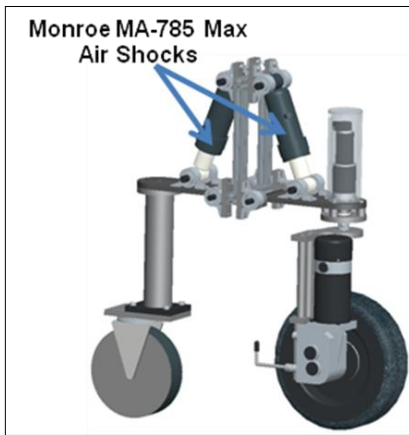

Figure 24: Final Design Suspension

The final design corrects the previous assumption that suspension acting perpendicular to the direction of travel would dissipate energy faster. Instead, the design reverts to the earlier concepts of suspension acting in line with the direction of travel. Figure 24 shows the finalized suspension and its connection to the redesigned frame. This figure shows minor modifications to individual parts in from the previous design to reflect the actual shocks, mounting plates, and connection pieces implemented in construction; however the concept is kept fairly consistent, albeit rotated 90° away from the direction of travel.

The suspension design is identical for driving and caster legs. This modular design includes mounting holes for steering motors on the caster wheel side to accommodate future work which intends to incorporate a four-wheel-drive system. The two additional driving wheel assemblies would be mounted to the same suspension mounts as the current caster wheel. The suspension utilizes four Monroe Max-Air adjustable air shocks for both absorption and dissipation of energy. These shocks can be loaded between 0 and 150 psi each and together, can account for over 4000 total pounds of loading.

The adjustable nature of these shocks allowed for some flexibility in design when estimating the device's weight and load capacity, and allows for future elaborations to be made without much concern for weight restrictions on the suspension. The design utilizes the stock mounting holes on the shocks and cut rods to mount the shocks to mounted bearing blocks attached to the frame. The connector plate also has these mounted bearing blocks affixed and is connected to the frame in a similar manner. This allows the entire suspension to move freely and allows the shocks to dissipate energy without subjecting the frame or user to significant strain.

The shocks are mounted in a way such that the position of the wheel and motor are always within a specified arc. Since there is only one degree of freedom for the movement of these components, the control system does not have to account for potential changes to its kinematic or dynamic model. This also aids in traversing environmental hazards normally considered too large for a given wheel size to overcome. Additionally, because the shocks are linked together, as one shock compresses or extends, the other shock automatically compensates in the opposite manner to provide a smoother ride. In the current design the two caster wheels' suspensions are linked together and are independent of the linked suspension of the driving motors. Each shock can utilize over 3 inches of compression to stabilize the system and dissipate energy.

Frame

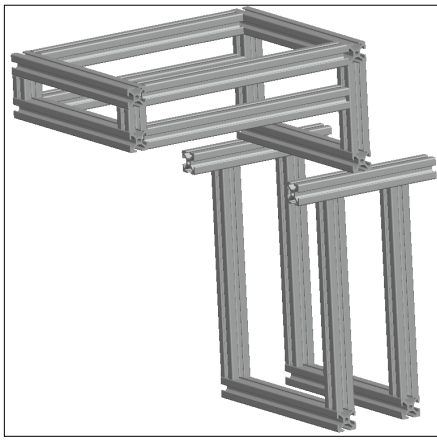

Figure 25: 80/20 T-slotted Aluminum

The frame for the final design differed significantly from previous concepts to accommodate the modified suspension and to successfully mount the control and power systems. It was constructed from 1x1 inch t-slotted aluminum 80/20 and is shown in Figure 25. This material was readily available, lightweight, durable, and flexible, which allowed for some minor shock absorption.

Because of the slotted nature of the 80/20 material and the various standard attachment devices available, minor modifications could be made to suspension mounting locations and even frame geometry without having to drill new holes or cut new pieces. Polycarbonate sheets were utilized to hold and protect the control and power systems and aluminum bars were screwed to the frame to mount bearing blocks for the suspension and connection plates. One side of the power systems enclosure was constructed using a hinge to allow for easier access to the various subsystems without requiring a full disassembly.

A main consideration in the current design is the flexible nature of the 80/20 and the mounting techniques commonly used. The 80/20 is relatively thin aluminum allowing for moderate moments to impose great deflection. This problem is particularly evident at

the handles' mounting location where several additional mounting supports were necessary to create a stable structure. The mounting techniques commonly used for the 80/20 do not do an adequate job of resisting shear forces to the mount and are prone to loosening. Both issues are most likely due to the low friction surfaces present between the smooth aluminum and painted steel washers that are held together only in compression and are commonly used for construction. Figure 26 shows an

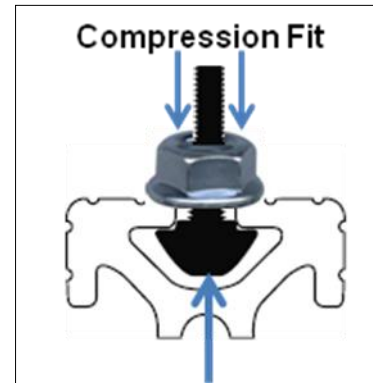

Figure 26: Compression Fit 80/20 T-Slotted

example of this compression fitting relying on friction to counteract movement. This problem is made substantially worse by the relatively intense vibratory elements present in the entire structure due to the types of terrains this vehicle traverses.

Handle

The full handle assembly, shown in Figure 27, is adjustable for height, width, and depth to accommodate a diverse range of body types while maintaining a consistent control scheme. The heights range from 30 to 36 inches from the ground, the widths range from 12 to 19.5 inches, and the depth ranges from 9 to 11.5 inches.

These measurements correspond to typical current generation walkers and are

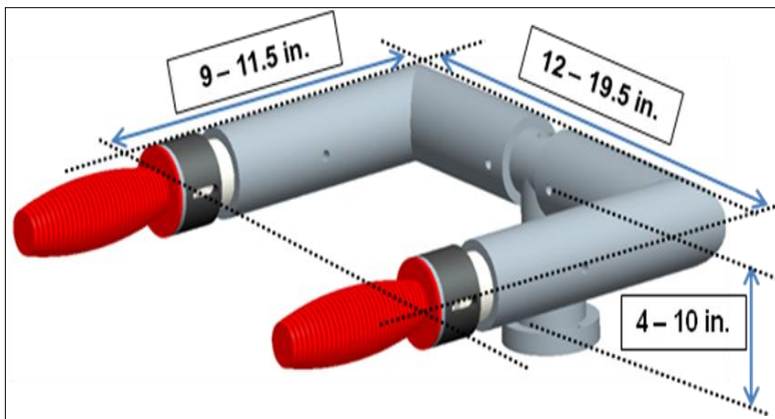

Figure 27: Dimensioned Handle Assembly

adjusted by concentric aluminum tubing with bolts

fastened between the layers of tubing. The potentiometers are housed within some of these tubes, which hold the springs and are kept from rotating by two straight rods. Because of the concentric nature of the design, each outer piece is easily removed to exchange or adjust components contained within, such as the potentiometers or springs, without having to completely disassemble the entire assembly. The majority of the

assembly is constructed from aluminum to reduce weight; however, the mounts for the handles were made of steel to keep the handles straight and make welding easier. Additionally, the handle grips were purchased and are made of the standard rubber material used in most walkers and bicycles. This handle design utilizes larger diameter aluminum tubing than previous designs so there is sufficient room for the necessary electrical components and so that the handle assembly is more robust. A disadvantage of these robust components is that the weight of the handles tends to create a large moment at the attachment point.

Leg Assemblies

The front wheels of the final design are very simple and are modified only slightly from the previous concept. The same offset swivel caster wheels are mounted directly to the suspension plate, but now utilize aluminum tubing, shown in Figure 28, that was readily available to us. The rear driving wheels still utilize driving motor/wheel combinations



Figure 29: Driving Wheel

the mounting and connection pieces for this combination

are seen in Figure 29. Preexisting mounting holes were utilized to mount a connection piece from the driving motor directly to a shaft adapter on the steering motor. As seen in Figure 30, thrust bearings were utilized on both sides of the

connector plate to divert lateral stresses away from the fragile motor shaft, and protective sleeves were incorporated to

prevent the mounting bolts from shearing.

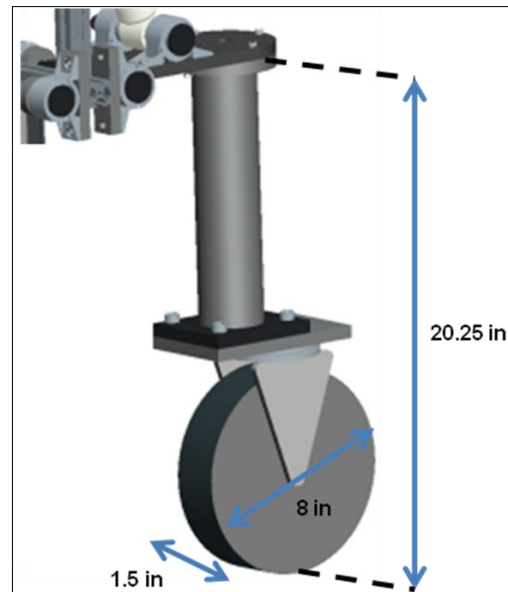

Figure 28: Caster Wheel Arrangement

This device incorporates many of the favorable components of the previous designs and reflects modifications made throughout the manufacturing process to simply the build. The design process for this device was arduous and

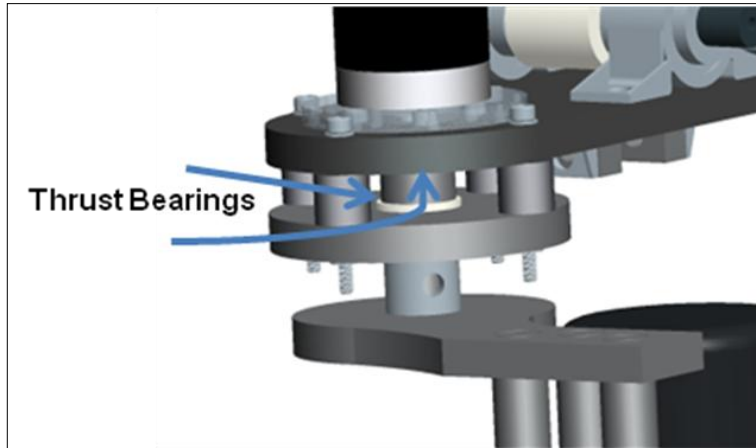

Figure 30: Thrust Bearings Mounted at Connector Plate

thorough which allowed the construction to take place rather seamlessly. To ensure the quality of the various fabricated components in this design, we worked closely with the FAMU-FSU Machine Shop and utilized their expertise to make manufacturing easier. Small sets of drawings and basic sub-assemblies were created to allow more chances to both check the precision of the manufacturing and allow for necessary modifications to be made. Regular visits to the shop, constant communication and physical involvement in component assembly and production resulted in a relatively easy assembly with very few and minor modifications necessary.

(4.0) Engineering Economics

The project budget allocation from CISCOR was \$5000. CISCOR also graciously provided many of the essential hardware and electrical components necessary for assembly, allowing the finance of other integral parts necessary for the walker. Parts provided by CISCOR include the, motor drivers and all computer control logic hardware. All additional components on the walker were either ordered online or fabricated through the Machine Shop at the FSU/FAMU College of Engineering. An itemized budget list is provided in Appendix X. The project is expecting to stay within budget while satisfying both our sponsor and project advisor's objectives. Various system components on our walker are recyclable, allowing future projects to reuse the equipment.

(5.0) Results and Discussion

Initial Tests

In order to successfully design and construct an outdoor robotic walker, a number of preliminary tests were required to check component performance and make necessary modifications. The driving motors were tested to make sure proper readings were being obtained from the mounted encoders. The air shocks were tested for leaks, and their compression in response to applied load at various psi levels was characterized. Additionally, the potentiometers were tested and their resistance in response to displacement was characterized. The procedures and results from these tests are described below.

Driving Motors

To stay within in budget and acquire essential components quickly, the driving motor and wheel combinations were purchased from eBay. Because of this, very few specifications were given before purchasing, and an optical encoder was not included or mounted to the device. By removing the breaks from these motors, a shaft was made available to

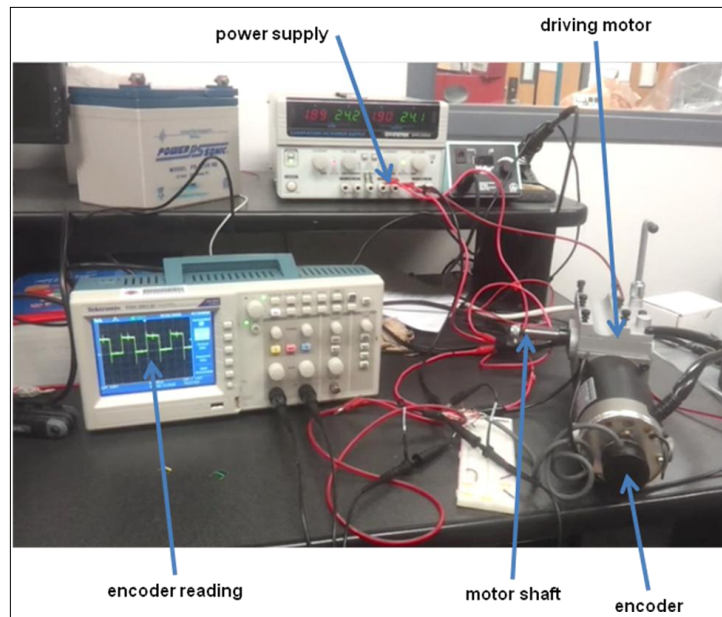

Figure 31: Testing setup of Driving Motors & Encoders

mount the encoders. To test these encoders (and make sure the motors actually worked), the motors were connected to a power supply and the encoders to an oscilloscope. Figure 31 shows the oscilloscope registering the appropriate square waves from the encoder as the motor spins. Additionally, this test showed the no load current draw of around 4 A which is well inside the 60 Amp (continuous) limit of the motor driver. This ensures that the motor controller and computer will be able to accurately control the driving motors.

Air Shocks

In order to test the air shocks for leaks, the devices were filled with an air compressor to 35 psi and allowed to rest overnight loaded with approximately 140 pounds. After the resting period, the devices were measured again and found to be at 32 psi. This small drop can be accounted for by the losses incurred through the actual measuring of pressure. Therefore, it can be concluded that the air shocks can successfully maintain pressure.

With this conclusion, the devices were tested at various pressure levels to characterize their maximum compression with applied loading. The devices were oriented vertically and a steel rod was placed through the preexisting mounting eyes. Weights of known mass (provided by the FSU Muscle Lab) were affixed onto the rods resulting in a downward compression. A ruler provided reference for this compression.

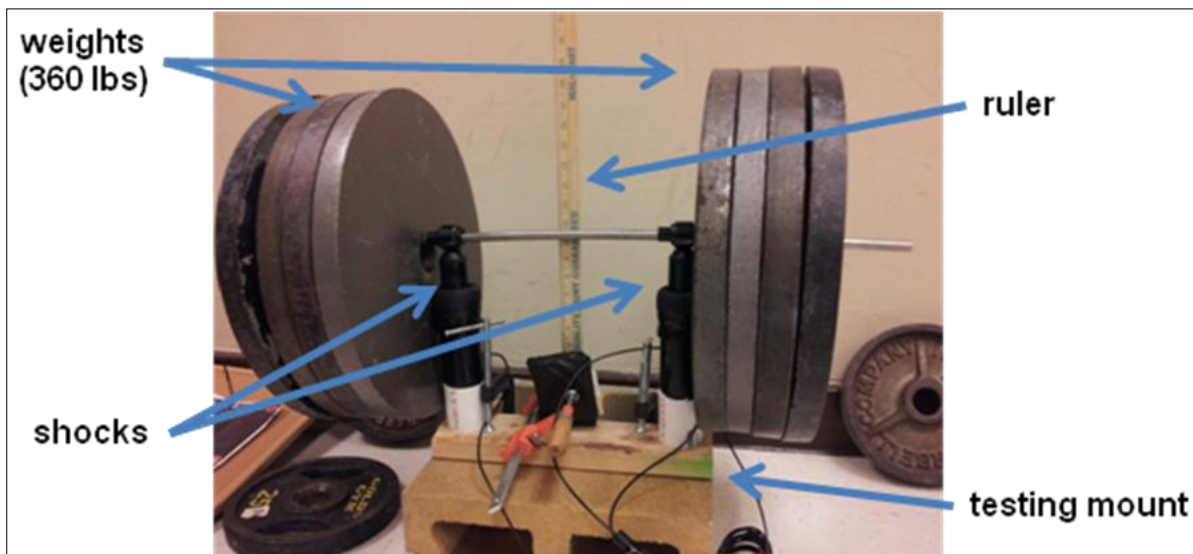

Figure 32: Testing setup for Monroe Air Shocks

Because the shocks are sealed in pairs, the test was required to be conducted using two shocks; therefore the true applied loading was half of the recorded measurement. The entire testing apparatus is shown in Figure 36, and the results were recorded, tabulated, and plotted in MatLab as shown in Figure 33.

From observing this plot, the compression increases with loading and decreases with pressure. It can be seen that the shocks are not linearly responsive to applied loading nor are they linearly related as pressure increases. This makes calculations more complicated; however using this plot, estimations can be made to determine the appropriate pressure loadings at given loadings and known compression limits. Conversely, the plot can also be used to calculate an approximate range of safe loadings at a known pressure level.

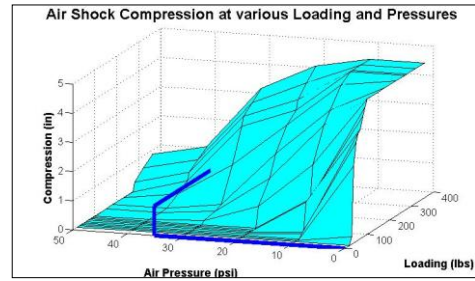

Figure 33: MatLab plot for shock compression vs. loading at various psi

Potentiometers

The potentiometers to be used in the handle assembly to convert a user input force into a proportional voltage were rated as 10k Ω linear potentiometers. Because these devices were very inexpensive, there was some doubt of their linear precision. Since the entirety of the control system relies on minor displacements (less than 1 inch) in these potentiometers, the verification of the accuracy of these measurements was pertinent. Therefore, a simple test, shown in Figure 34 was implemented to check the accuracy of the potentiometers. The resistance was recorded at incremental wiper distances and plotted in Figure 35. As shown in



Figure 34: Setup for potentiometer Test

the figure, the device actually closely approximated the linear behavior specified. With this characterization, appropriate controls can be determined to convert user force input into proportional output voltage.

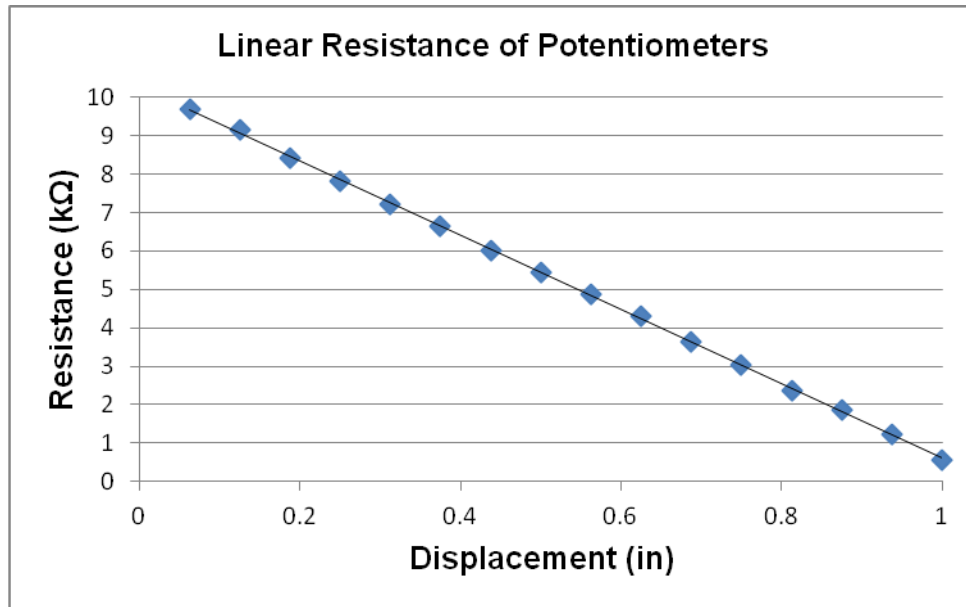

Figure 35: Excel plot of potentiometer Resistance vs. Displacement

Design Tests

After the device was completely constructed, certain system performance tests were performed to verify the device's capabilities and compare the performance to stated objectives. The air shocks were mounted and the pressure was adjusted to balance the natural weight of the system. The steering and driving motors were both independently tested under loading. Additionally, the system was tested on a variety of surfaces to characterize its performance.

- *Air Shocks*

The air shocks were mounted to the system and filled to the estimated pressure levels based on the experimental calibration, but these estimations did not take into account the initial pressure of loading from the body. They were expected to sit naturally (mounting plate horizontal) at a compression of 1 in. This was to allow the shocks to extend the legs down slightly with the device encountered a divot in the terrain and still compress to an appropriate height to traverse over obstacles. However, because of the non-linearity of the shocks, once the shock began to compress and it was difficult maintain a state of constant compression. This led to the remounting of the shocks to allow the system to rest

at a fully extended state. The shocks were then able to successfully support the device at pressures close to those estimated by the experimental characterization.

- *Steering Motors*

The steering motors were tested independently and without use of the onboard motor drivers to limit the number of variables in the testing situation. With the walker fully loaded, the operational voltage of was slowly brought up to 24 volts. The amount of current allowed to pass was limited to about 3 amps (approximately half of the maximum current possible). As expected, with increasing voltage and current, the steering motor was able to reorient the driving motor quicker and with more force. A picture of this test is shown in Figure 36 This test was entirely successful. Based on initial calculations, the steering motor was predicted to be capable of rotating the driving motor 360 degrees in less than one second. These calculations were experimentally verified



Figure 36: Driving Shaft Steering Motor Alignment

as the motor was able to spin 180 degrees in well under a second only, under half power. The steering motors must have the ability to quickly react as the driving motors will need to be constantly and quickly adjusted to maintain a given orientation. This test showed that care must be taken with these motors, as it is quite possible that if the maximum current was applied to these motors then it is likely components can fail due to the extreme forces present.

- *Driving Motors*

The driving motors were also tested independently and without the use of the onboard motor drivers to limit the number of variables in the testing situation. After testing the steering motors, it was also quite apparent that it was necessary to be able to quickly turn the system off because of the potentially large forces present. With the wheels not in contact with the ground, the motors were tested on a laboratory power supply. Varying voltage and current combinations were tested. Ultimately it was decided that at 12 volts, half of the suggested operational voltage of the motor, the current did not have to be limited to ensure safe operation. With these initial tests completed we decided we were ready to allow the walker to move under its own power.

The decision was made to move outdoors so the walker did not run into anyone/things and also to allow the walker to move on a variety of surfaces. Pictured in Figure 37 is the walker moving under its own power outside. With only one battery connected the motor was allowed essentially all the current it could consume at 12



Figure 37: Picture Progression of Walker moving on its own power

volts. This led to a very reasonable walking speed which shows that at 24 volts the system will be quite quick and that the system can be loaded with much more weight and still successfully operates. Because these are wheelchair motors, they are designed to operate with approximately 400-500 pounds shared on the driving wheels and wheel chair casters. Therefore, our 200 pounds shared on the driving wheels and casters is well under the capability of these motors.

- *Various Surfaces*

In order to test the suspension and get rough estimates as to whether or not the system would be able to move itself over a variety of terrains the steering motors were locked from moving and the clutch for the driving motor was disengaged. This essentially made the walker passive and differentially steered. The walker was then taken over a variety of surfaces including gravel, cement, grass and tile/carpet. Various surface testing can be seen in Figure 38. The device performed perfectly under all situations, save for the casters interaction with the gravel. The random size and orientation of the gravel rocks caused the caster wheels to change their orientations rapidly as they apparently did not have enough weight on them.

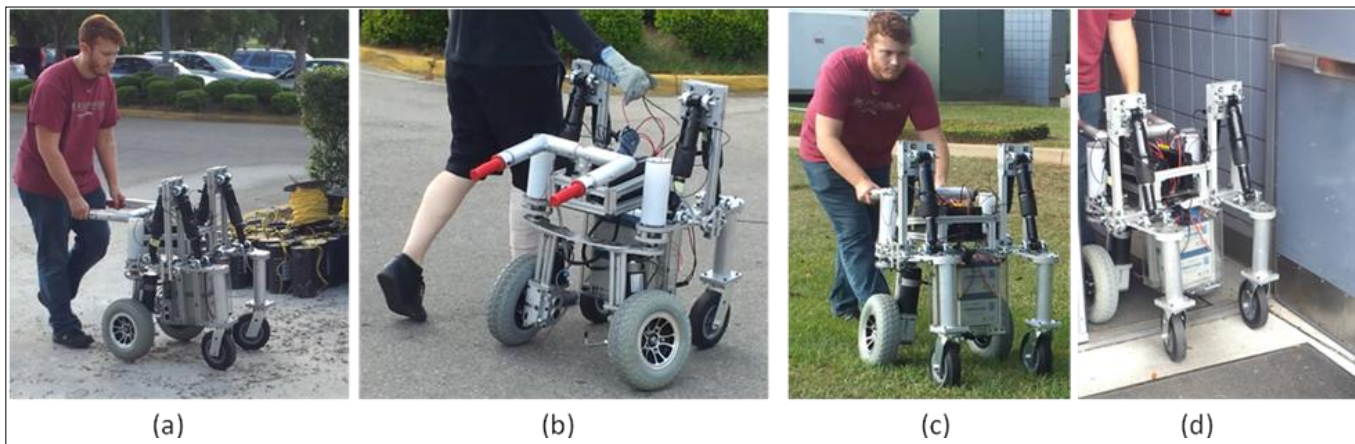

Figure 38: Various Surface Test (a) Gravel (b) Cement (c) Grass (d) Tile and Carpet

Otherwise the walker was able to efficiently and quickly move over the terrains with only a small amount of force from the user, anywhere from 20 to 50 pounds of force. The walker was also taken over larger obstacles in order to test the suspension and determine if the wheel size was sufficient.

Ultimately it was determined that although the current design works, the walker would benefit from increased diameter caster wheels made of a softer material. The larger diameter would help to traverse objects while the softer material would help to deal with surface irregularities such as those found on the gravel. It was also found that in the passive and differentially steered operation of the walker, the swivel nature of the caster led to some unpredictability and difficulty in moving from forward motion to backward motion quickly and easily as the caster wheel had a tendency to

move completely around the leg. The swivel nature of the caster wheels also presented a problem as they were sometimes entirely perpendicular to the obstacles that we wished to traverse which made surmounting these obstacles all but impossible without potential structural damage.

(6.0) Environment, Health and Safety

The purpose of this project is to improve the quality of life of the disabled and elderly community by augmenting their mobility restrictions, specifically in an outdoor environment. The final design contains some components that must be discussed to satisfy the health and safety requirements of our project. Since our project requirement was to design a research platform, our group was more concerned with the mechanical operation of the walker and less concerned with system aesthetics. With multiple machined parts, certain edges and burrs may present a source of physical harm to the user. The walker is powered by a set of two 12V lead-acid batteries. Although these lead-acid batteries are recyclable, our final prototype design presents a potential electrical hazard to the user.

Two 4600 RPM, 3.5 A electric motors drive the walker, and two DC Maxon Motors are used to steer the device. Using these electric motors saves harmful chemicals from being emitted into the atmosphere, preserving environmental health. Our walker is mainly composed of low-risk material, posing a minimal threat to the environment.

(7.0) Conclusion

It was proposed in this project to design and construct an assistive walking device to be used by the elderly and disabled population on a variety of terrains both indoors and outdoors. Such a device is necessary because the current generation of assistive walking devices offers limited mobility in outdoor environments and is greatly limited in assisting the user beyond providing passive support. The proposed device was to maintain the intuitiveness of standard walkers by incorporating a force-based user control system that transferred the forces naturally associated with walking into appropriate system motion responses. The device was designed to not only look aesthetically similar to standard

walkers, but also operate within the Americans with Disabilities Act (ADA) construction standards. Additionally, the device was designed to operate over various indoor and outdoor terrains, up and down slopes, and over small obstacles. Because this project's intent was to design the hardware for an initial research platform, the control of the device was not within the project scope; however the device was designed to be easily adapted in future continuing research efforts.

The design was to include a handle height between 32 and 39 inches off the ground with a width between 14 and 23 inches. It was to weigh less than 200 pounds but be able to support up to 300 pounds. The device was intended for use on tile, carpet, cement, grass, and gravel, and meant to traverse over obstacles up to 4 inches high and on slopes of at least 10° at a maximum operating speed of at least 5 mph. The device was also to include the ability to traverse in a semi-omni-directional manner, which involves moving transversely 45° from the center axis.

Five initial concepts were generated with these objectives and constraints in mind. Additionally, the designs attempted to maximize the versatility, robustness, user-friendliness, and indoor / outdoor operation capabilities while minimizing cost and weight. The first five concepts were evaluated based on these design criteria and the top three were examined further to create an amalgamation of their respective strengths. The interim designs each took steps at improving specific flaws in the previous design, specifically the suspension and frame. A final design was produced through this evolution and manufacturing of this design required only minor modifications.

The final design uses 1in x 1in t-slotted 80/20 aluminum for the frame, and Monroe Max-air adjustable shocks for the suspension. Adjustable aluminum handles house linear potentiometers attached to exchangeable springs to convert the user's natural pushing motion during walking into digital signals for the motors. The walker relies on two 4600 rpm motors salvaged from a used electric wheelchair and located in the rear of the walker for propulsion. The device utilizes two Maxon RE-max brushed high torque DC motors for turning. The system will eventually be controlled by a PC104 computer stack and four motor drivers powered by two 12V lead acid batteries. While these components are not currently active, they are completely wired and mounted onto the device for future convenience.

The various components (motors, shocks, and potentiometers) were tested both prior to and after assembly and proven to work sufficiently well in both scenarios. The constructed device successfully acted as a passive walker on tile, carpet, cement, and grass, and somewhat successfully traversed over gravel. The walker was successfully able to absorb the vibrations experienced through traversing uneven terrain and successfully navigated over an eight inch drop off. The device can easily support 100 pounds and stayed within the designated budget. Future work will involve programming the control system and reinforcing the frame. Additional tests will be conducted to recalibrate the air shocks and substantial weight reduction could be achieved through refabricating many overly designed components with lighter / less material or optimized geometries. Because of the modular nature of the device, this design will be the focus of continued research on force-based controls and semi-omni-directional motion. This research platform has the potential to become a marketed widely-used device, empowering the disabled and elderly populations everywhere.

(8.0) Acknowledgements

- CISCOR
 - Group 17 personally thanks CISCOR for providing the necessary means in accomplishing our projected Senior Design project goals.
- Dr. Oscar Chuy, Ph.D.
 - *Department of Mechanical Engineering*
 - As our faculty mentor, we would like to personally thank him for his continued support and advice throughout our entire Senior Design project.
- Dr. Emmanuel G. Collins, Ph.D.
 - *Department of Mechanical Engineering*
 - Would like to thank Dr. Collins for his collaboration in successfully completing our Senior Design project.
- Jon Cloos & Kimberly Snodgrass
 - Group 17 acknowledges our appreciation for Mr. Cloos and Ms. Snodgrass in their support in part order & receiving
- Machine Shop (75+ hrs)
 - Group 17 extends our gratitude to Jeremy Phillips, Dana Edmunds and Will Hartsfield for their hard work and contributions in the development of our walker.
- Keith Larson
 - Group 17 thanks Mr. Larson for providing necessary materials for our project
- Muscle Lab – Jordan Berke & Carlin White
 - Group 17 extends a personal thanks to Mr. Berke and Mr. White in offering their Muscle Lab to perform tests on our Air Shocks
- Andrew Whittington
 - Personal thanks to Mr. Whittington for inspirational and informational help in the design of our walker
- Auto shops
 - Thanks to Auto Zone & Tires Plus in actuating our Air Shocks

(9.0) Appendix

- Appendix A – Walker Components.....55
- Appendix B – Final Design Full Assembly.....78
- Appendix C – MatLab Code for Air Shock Test.....95
- Appendix D – Budget.....96

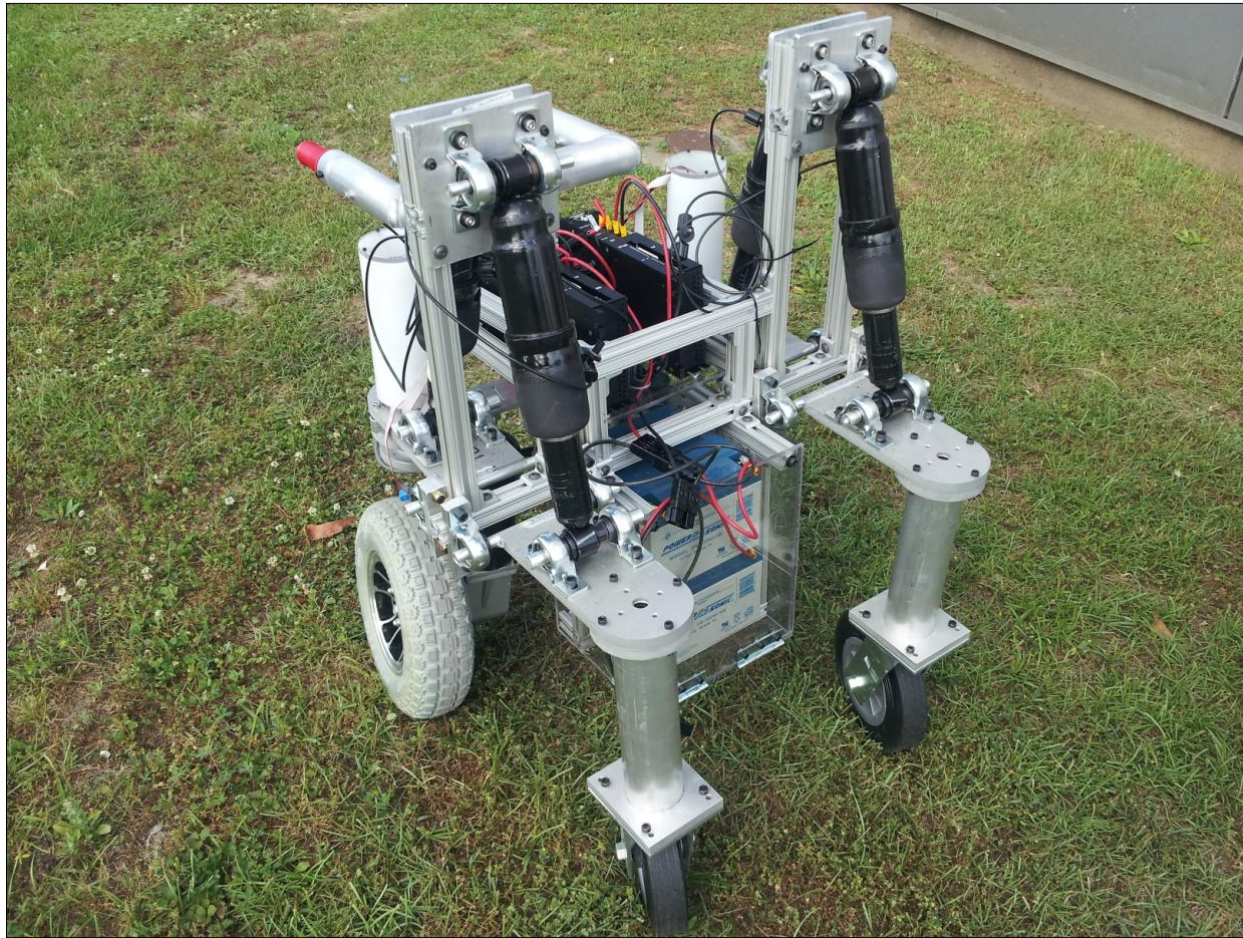
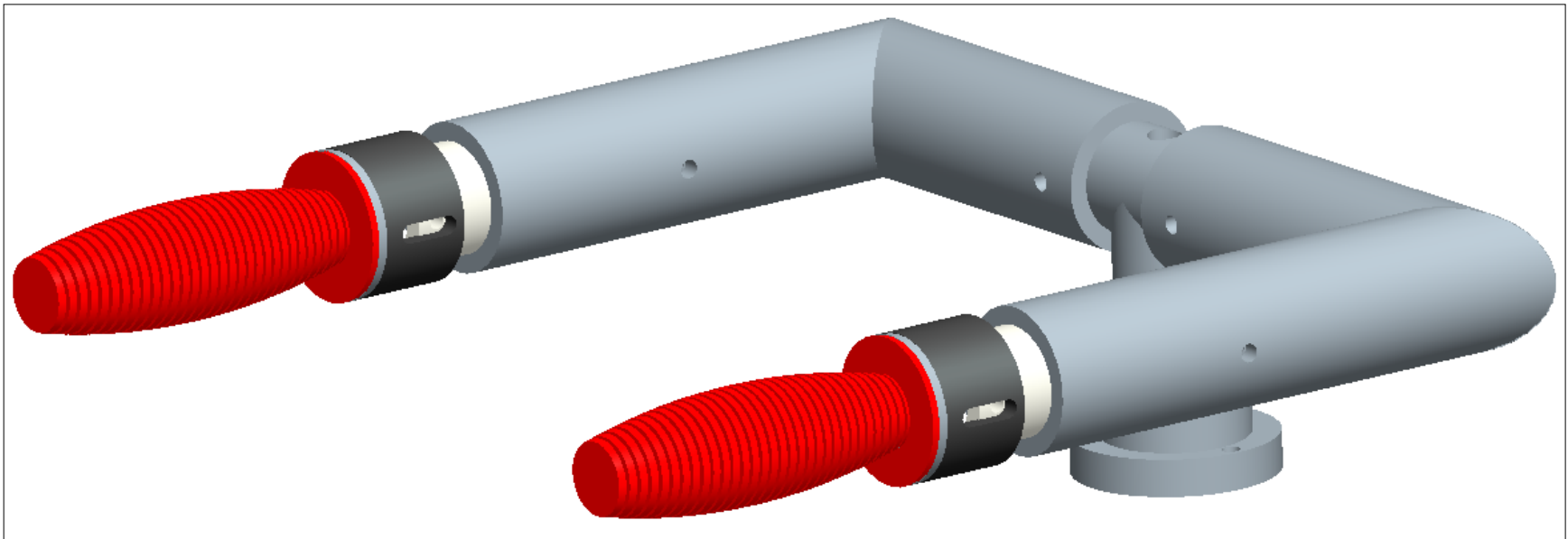
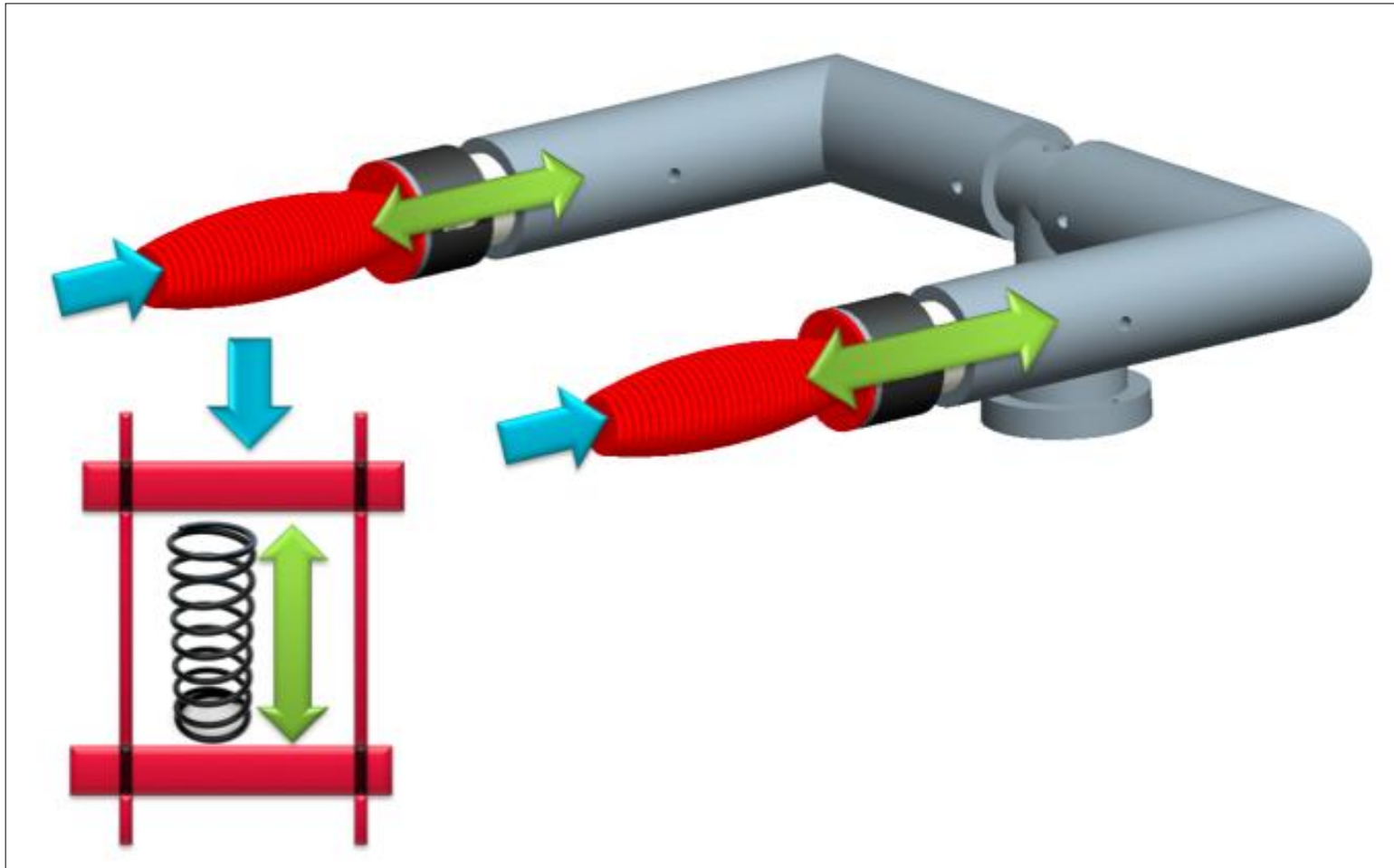

Figure 39: Actual Image of Complete Assembly

Appendix A – Walker Components



Complete Handle Assembly (Back Right Top View)



Force Input vs. Potentiometer Relation for Handle

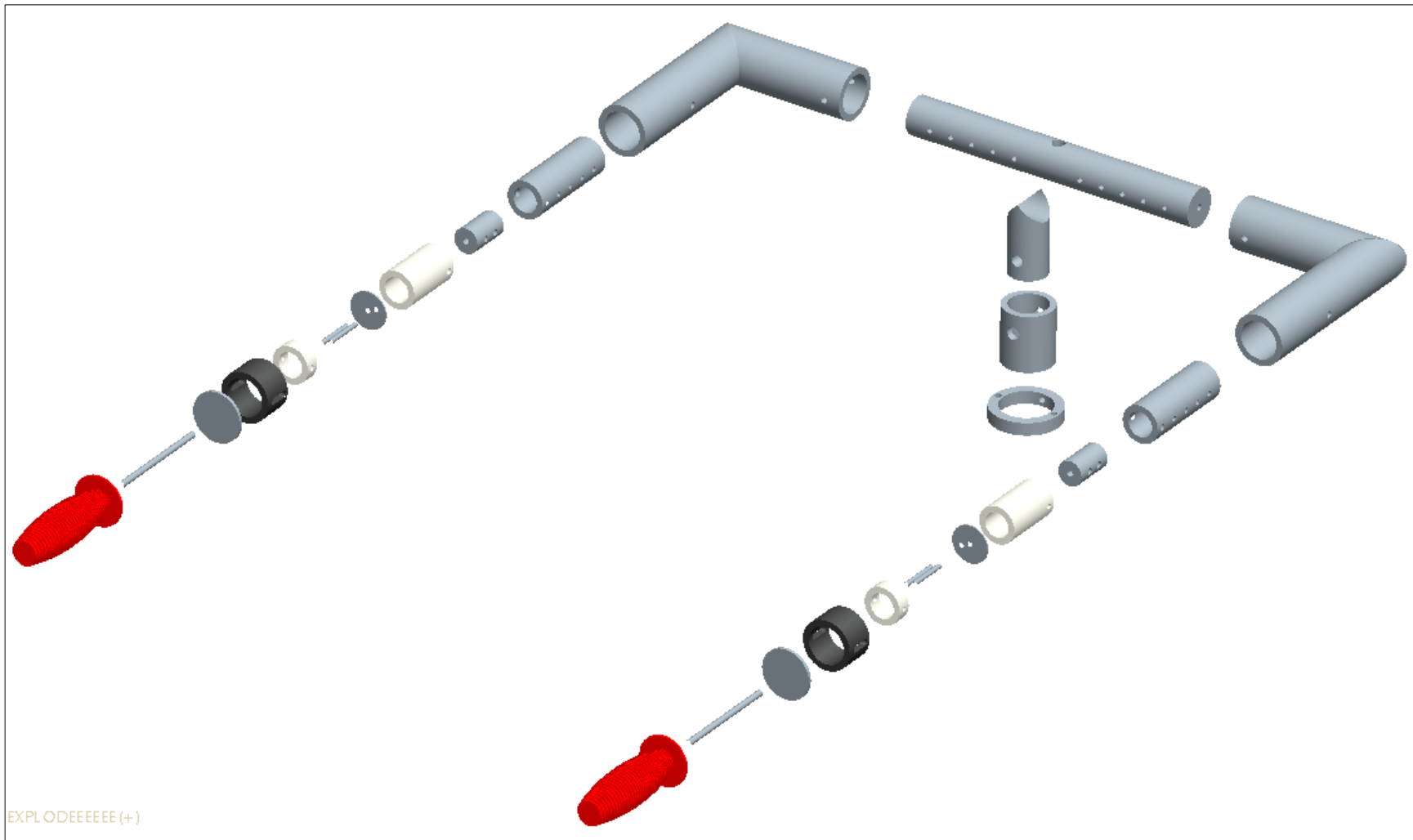

Exploded Handle Assembly (Back Right Top View)



Core Frame (Back Right Top View)

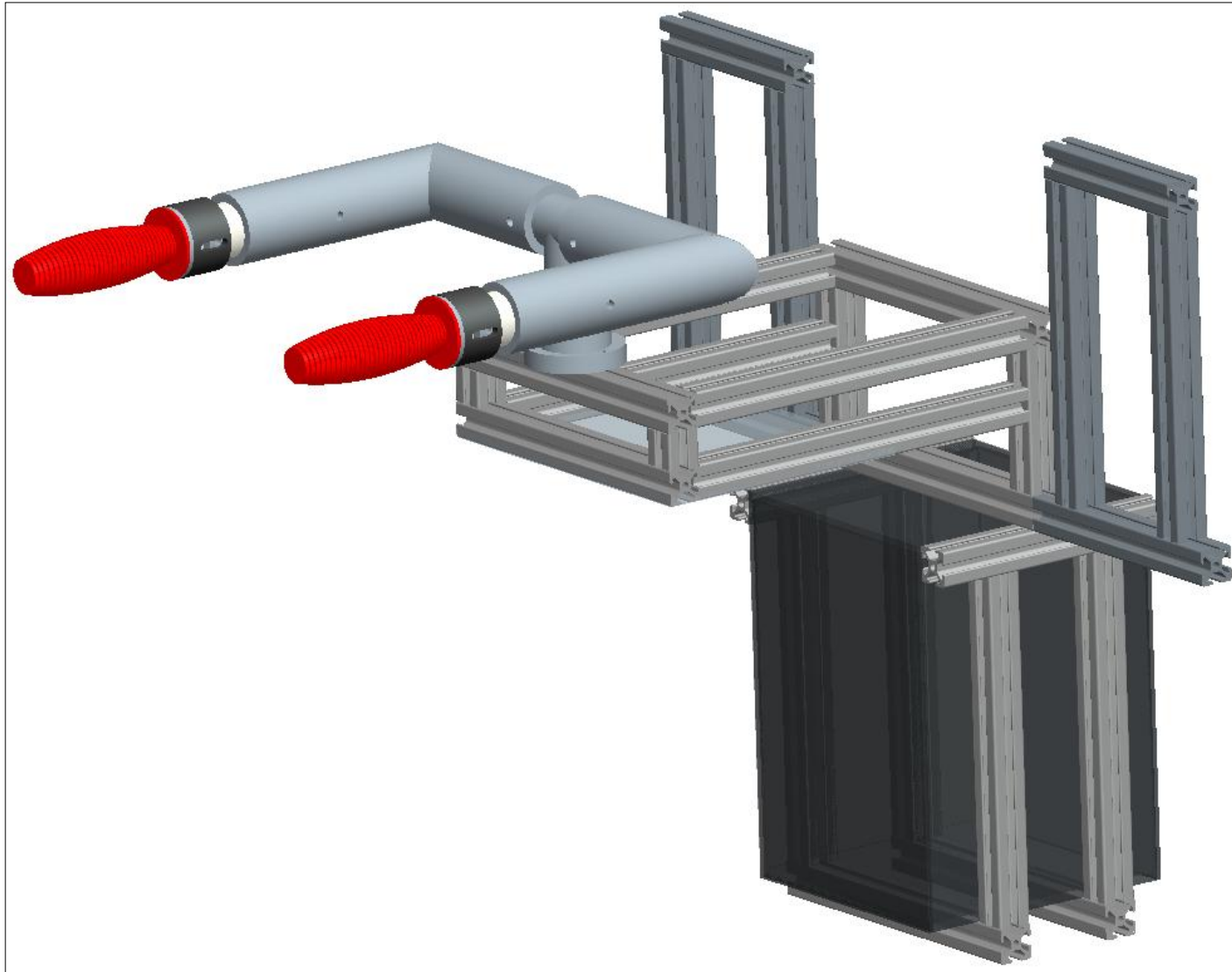

Core Frame with Battery & Handle Attachment (Back Right Top View)

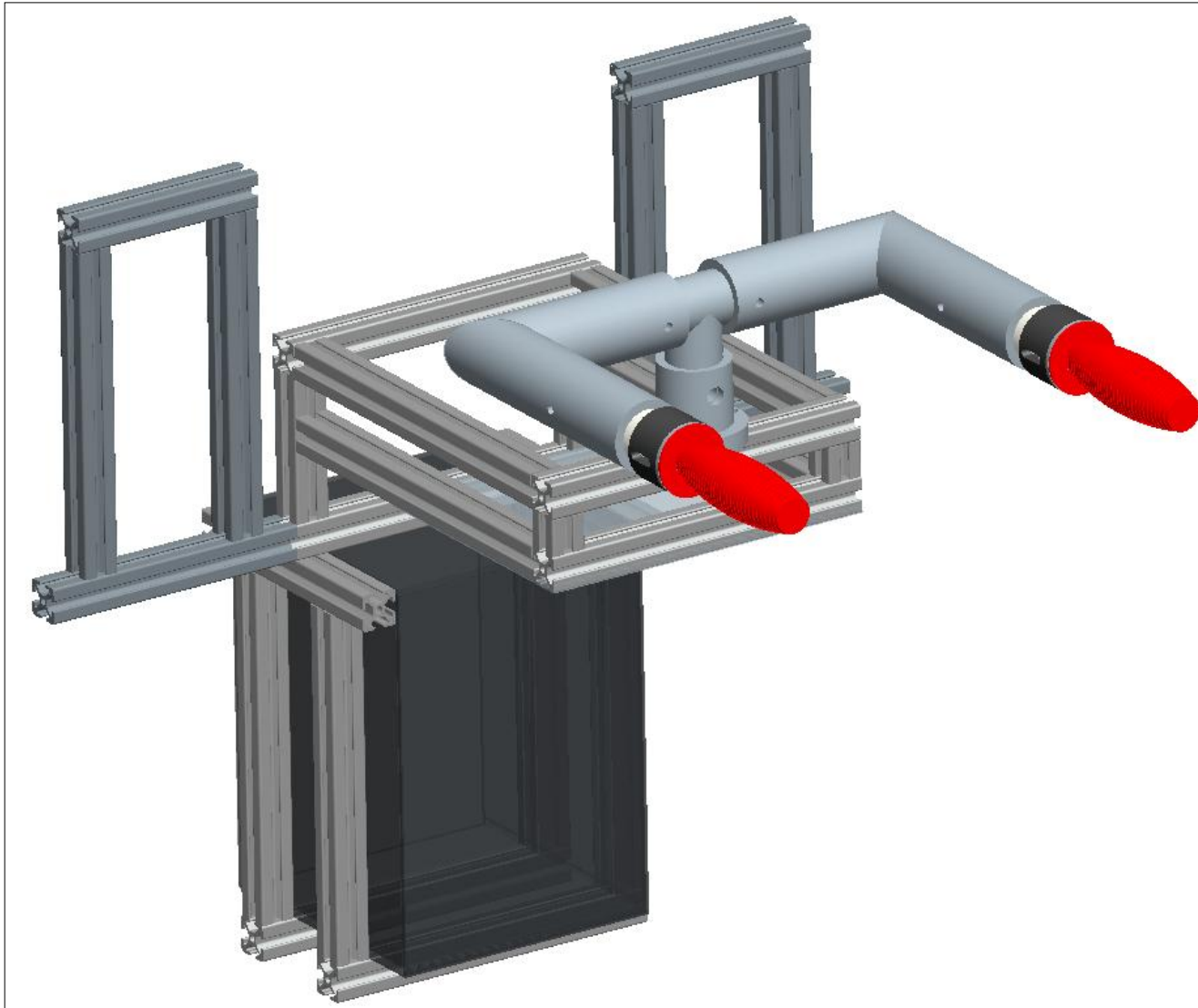

Core Frame with Battery & Handle Attachment (Back Left Top View)

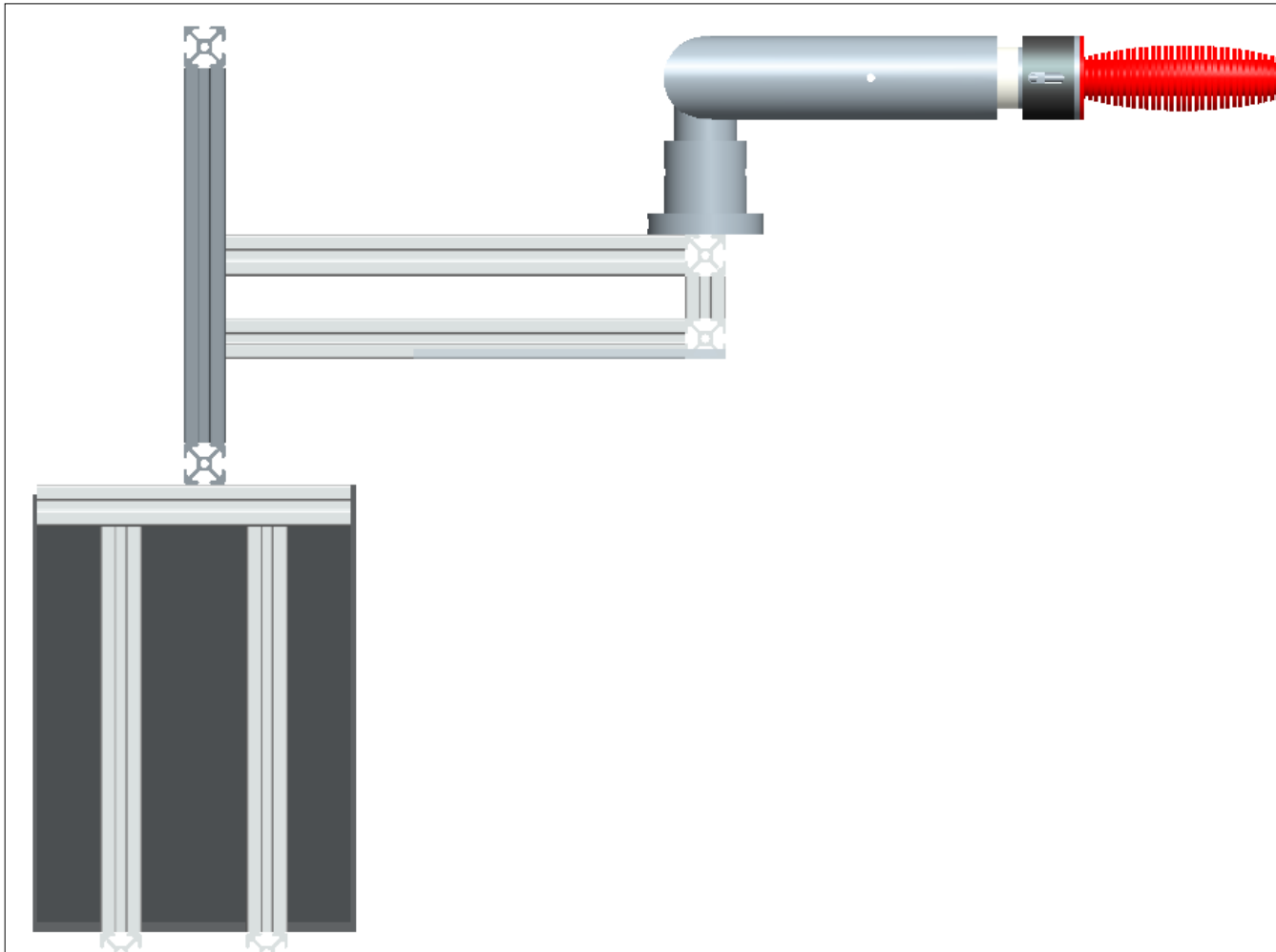

**Core Frame with Battery & Handle
Attachment (Left Side View)**

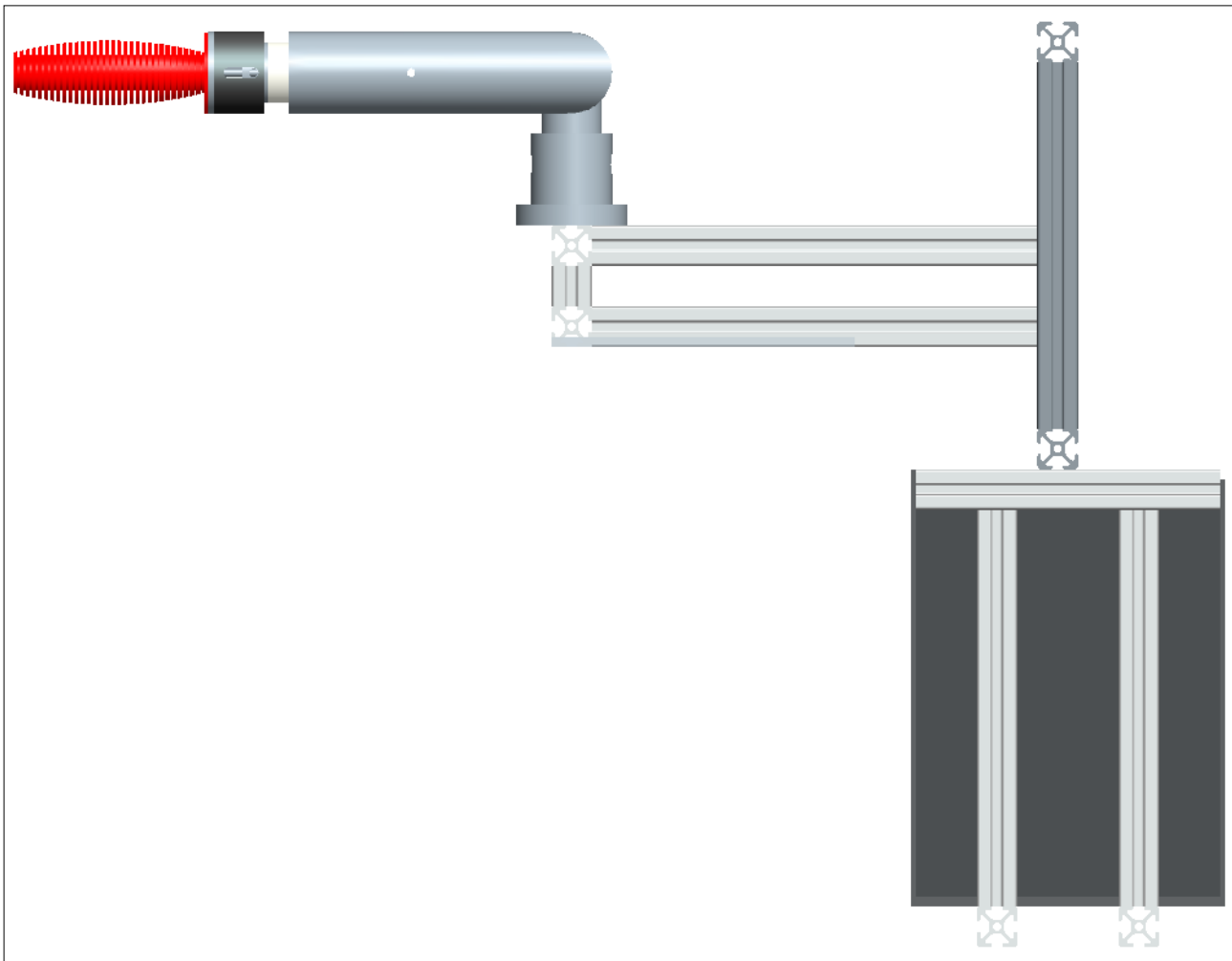

Core Frame with Battery & Handle Attachment (Right Side View)

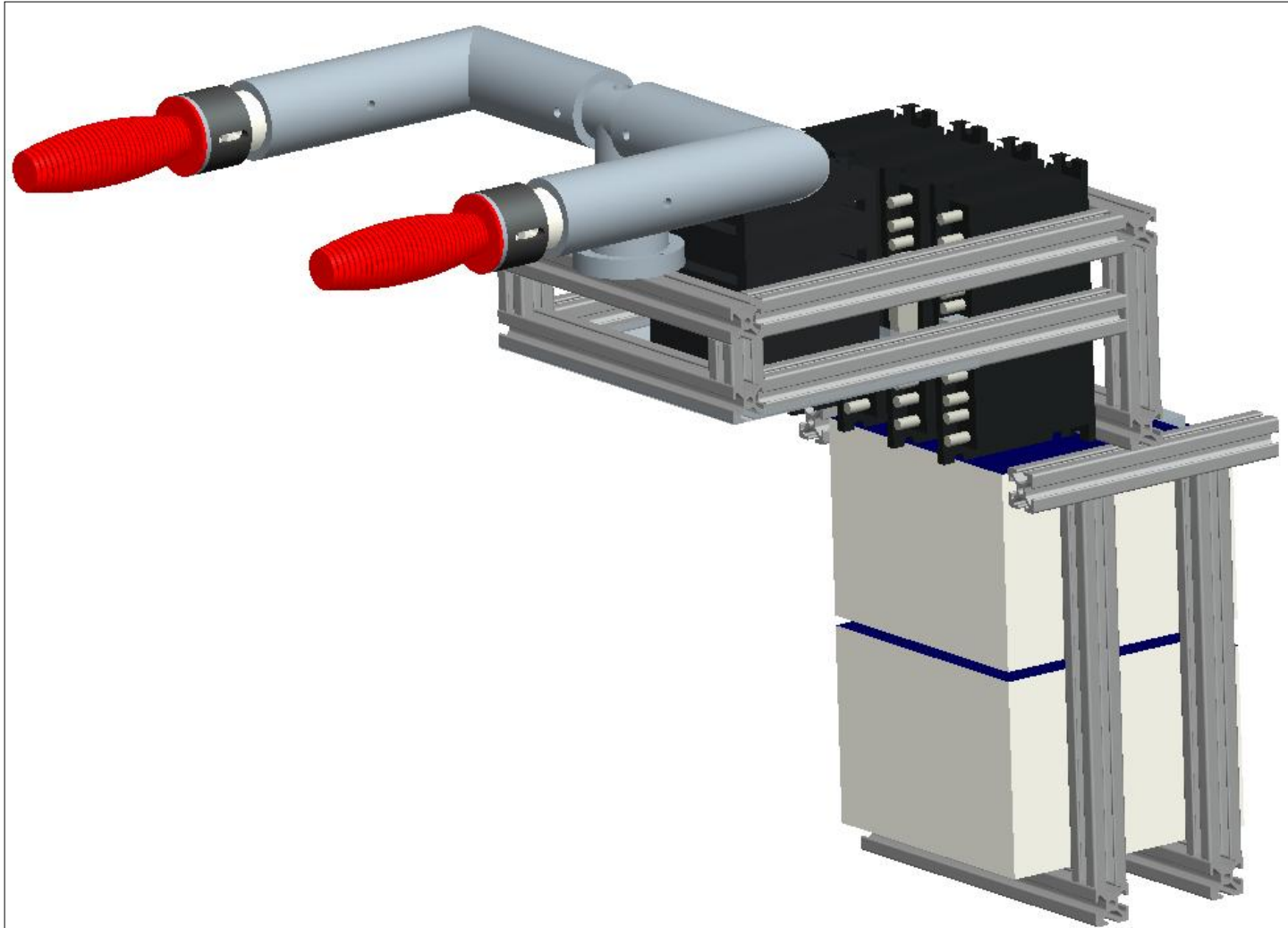

**Core Framing with Battery, Handle Assembly, and Computer Attachment
(Back Right Top View)**

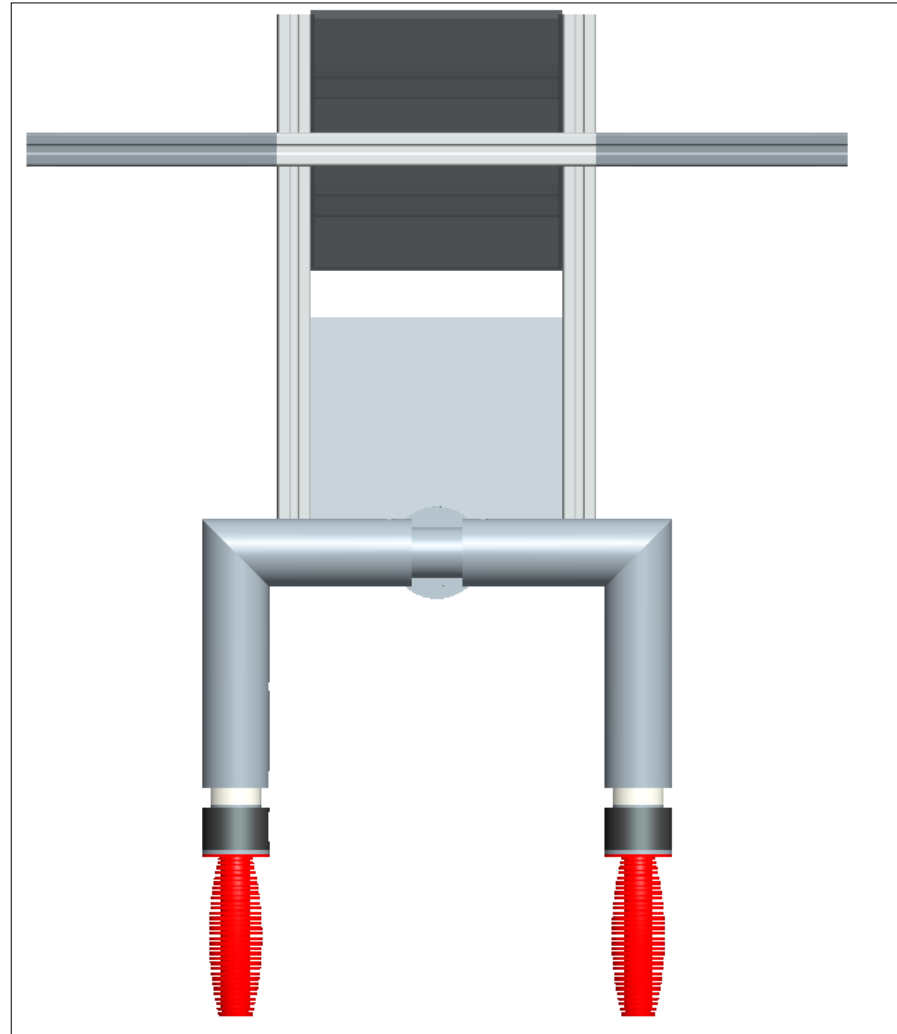

**Core Framing with Battery, Handle Assembly, and Computer Attachment
(Top View)**

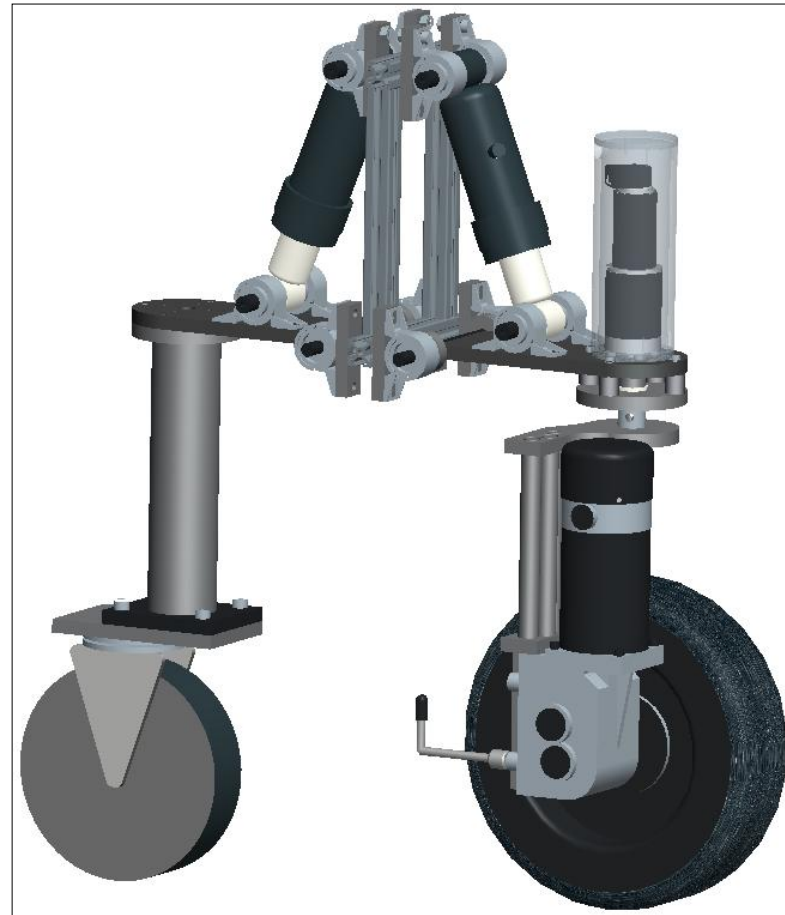

Singular Suspension Model

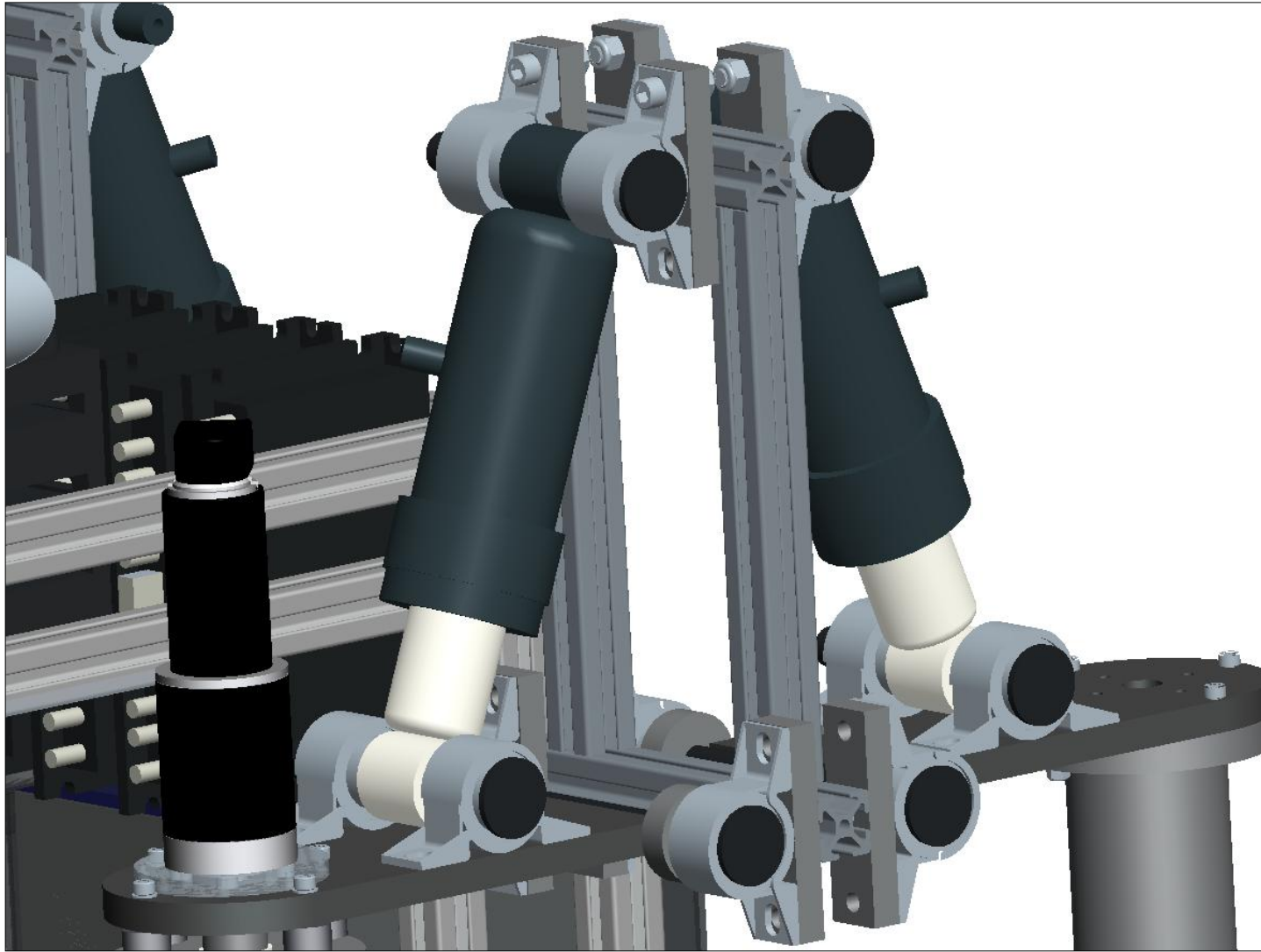

Complete Air Shock Assembly

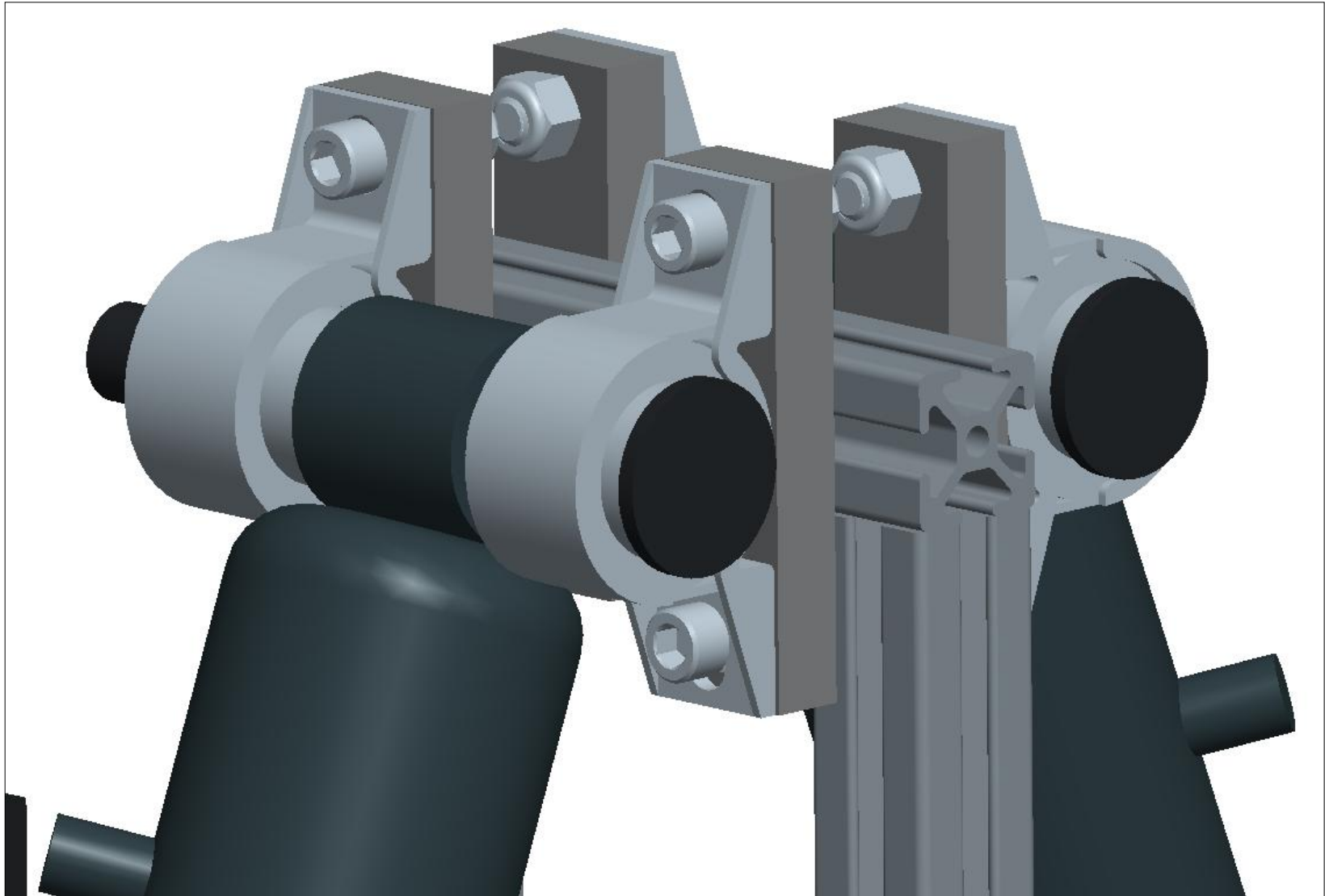

Close up of Upper Air Shock Mounts

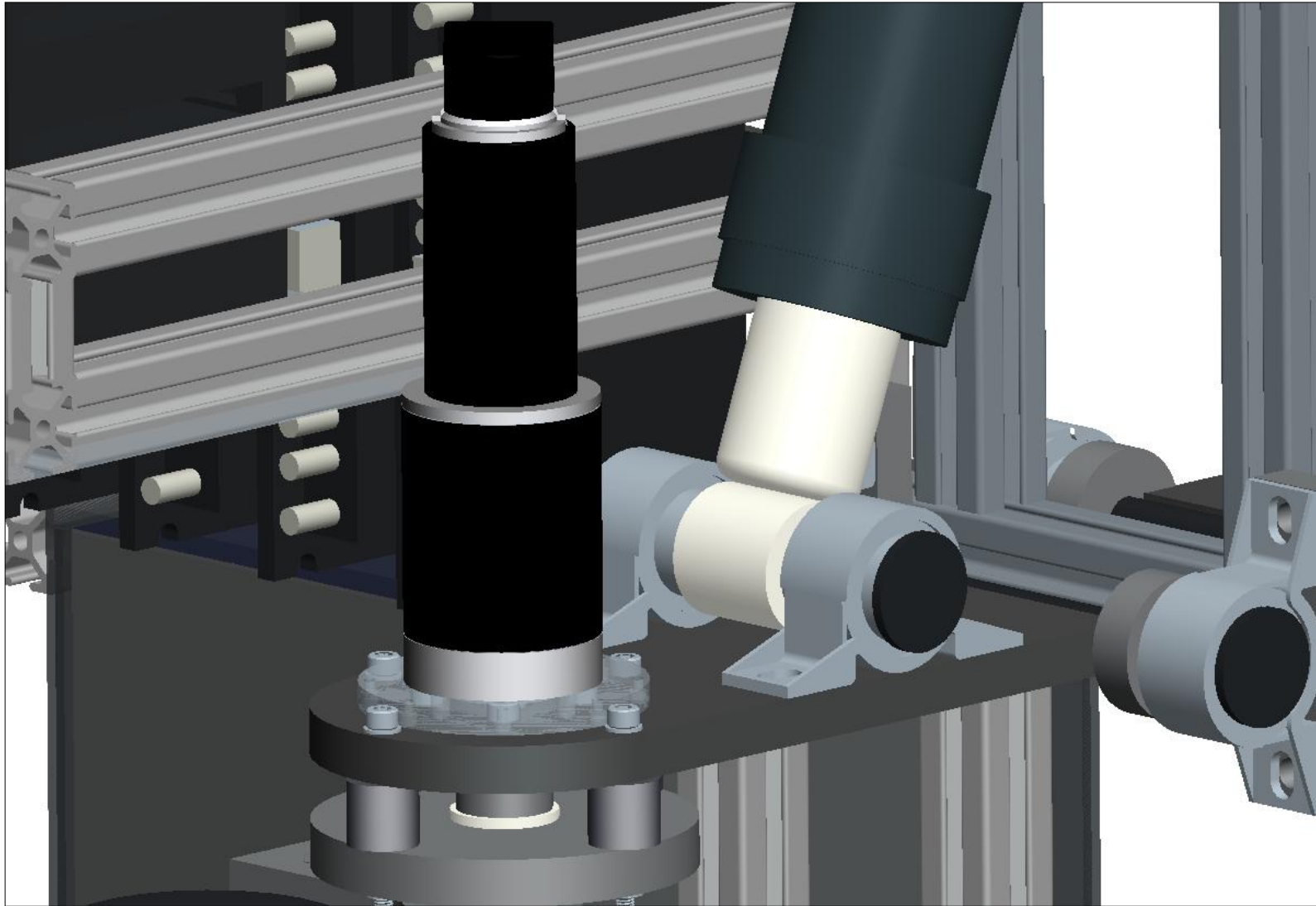

Close up of Lower Right Air Shock Mount & Steering Motor

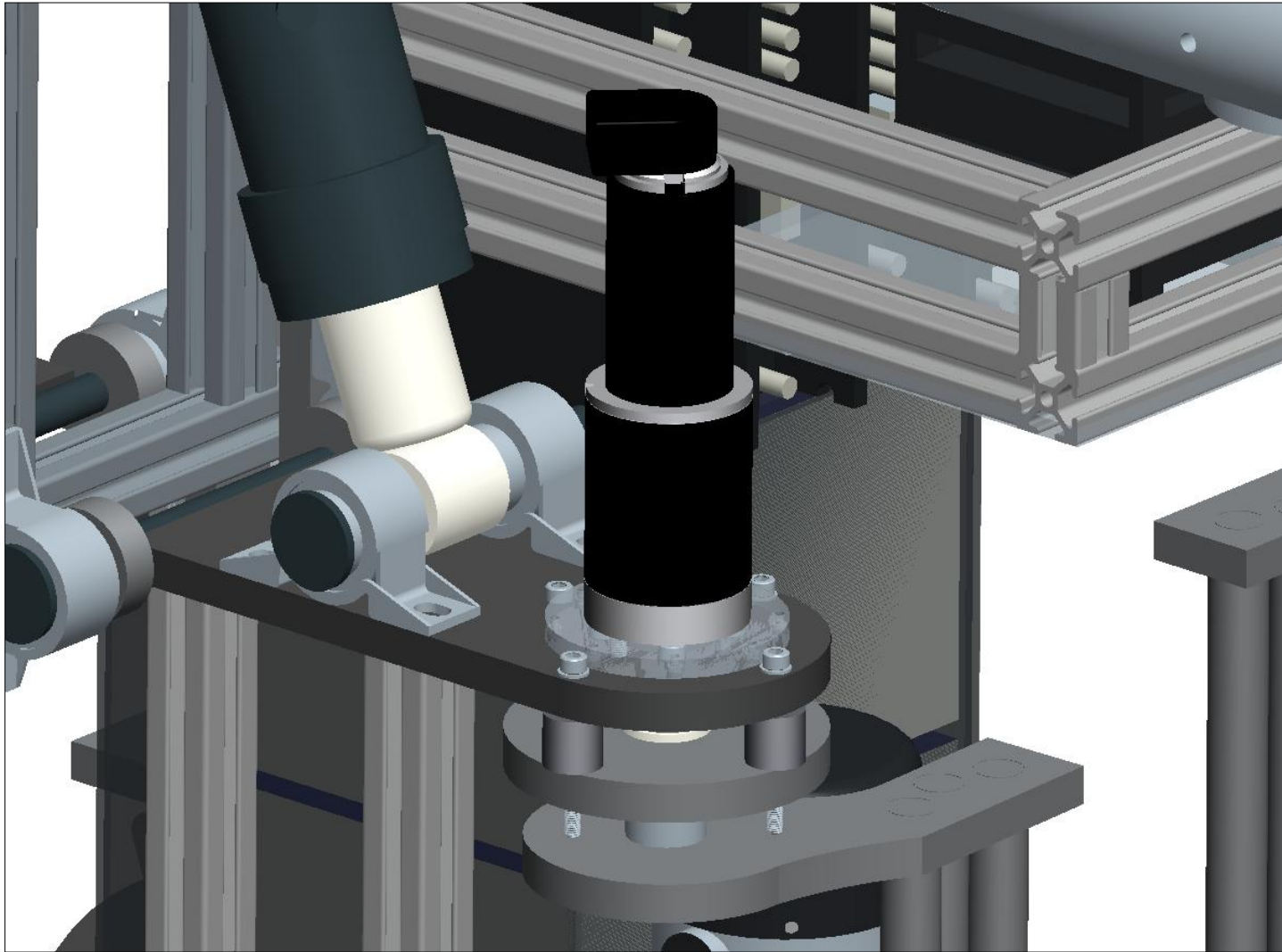

Close up of Lower Left Air Shock Assembly & Steering Motor

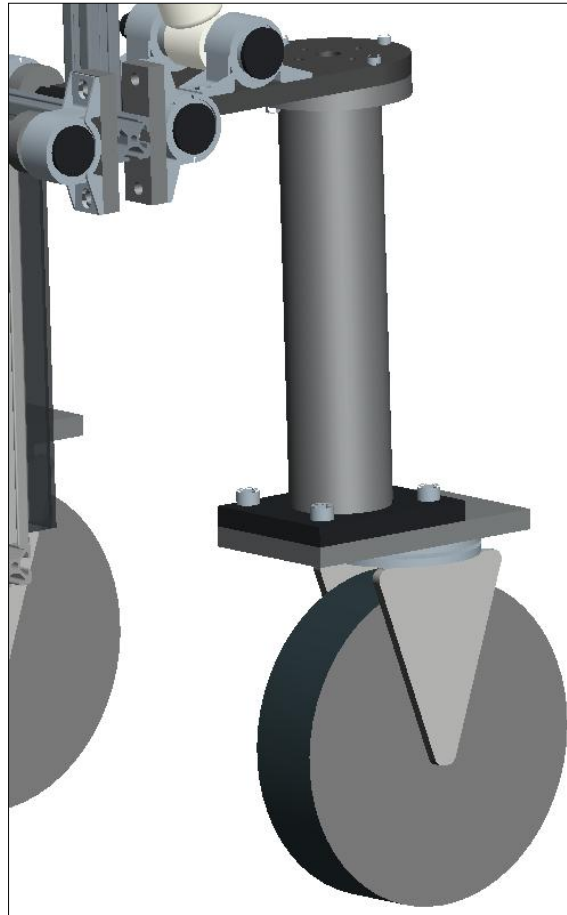

Right Caster Assembly

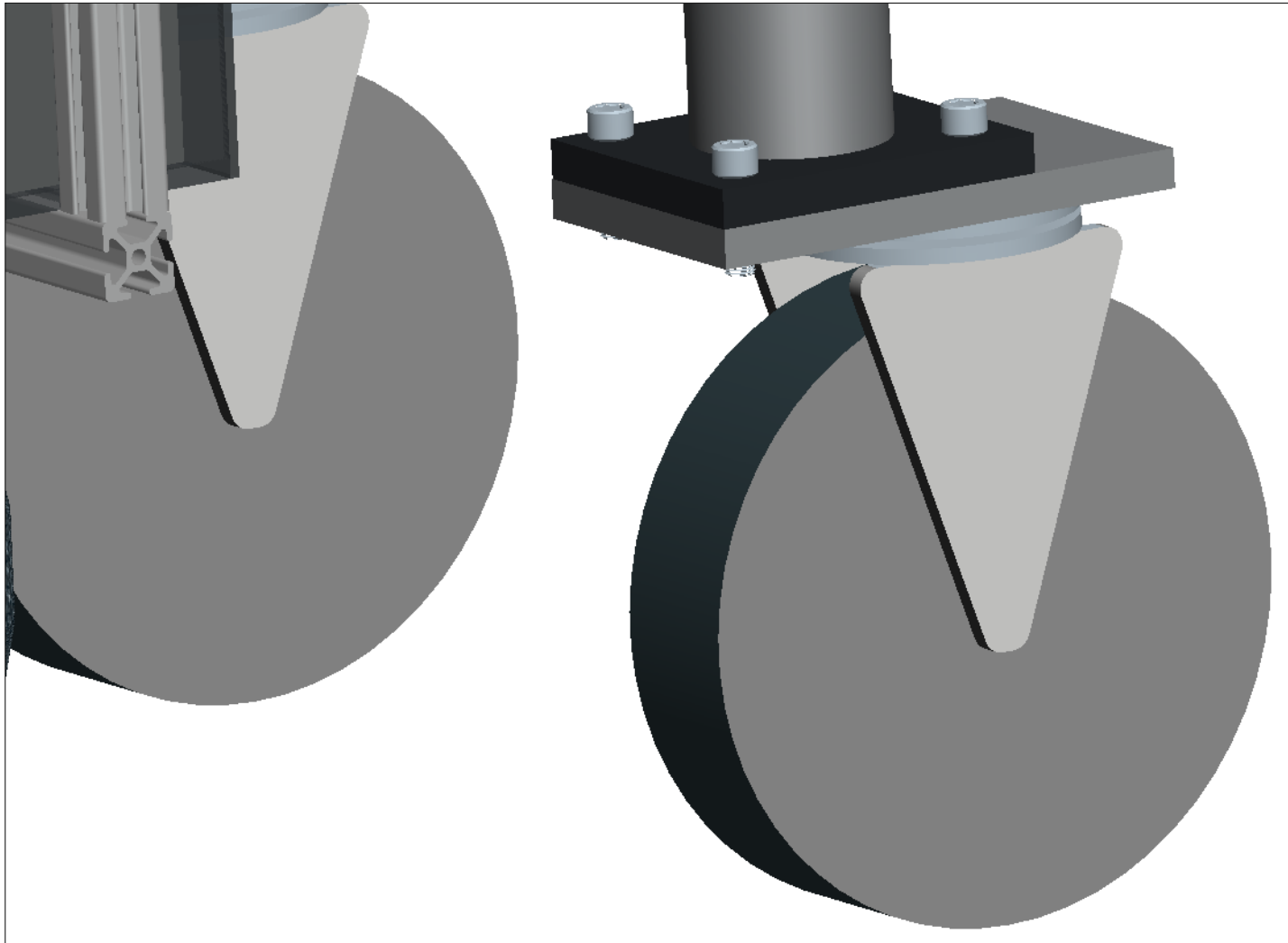

Close up of offset swivel caster

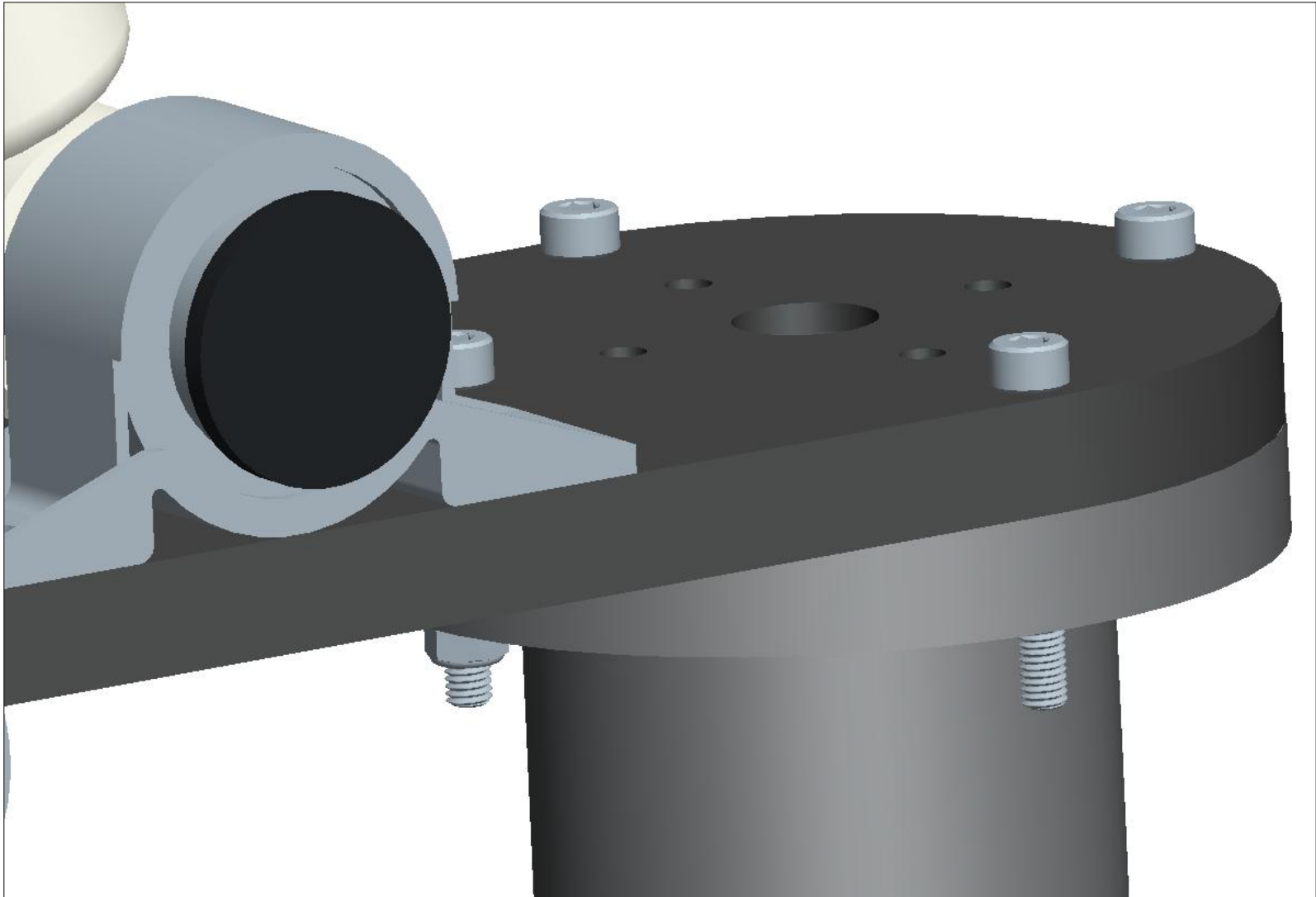

Close up of caster leg suspension mount

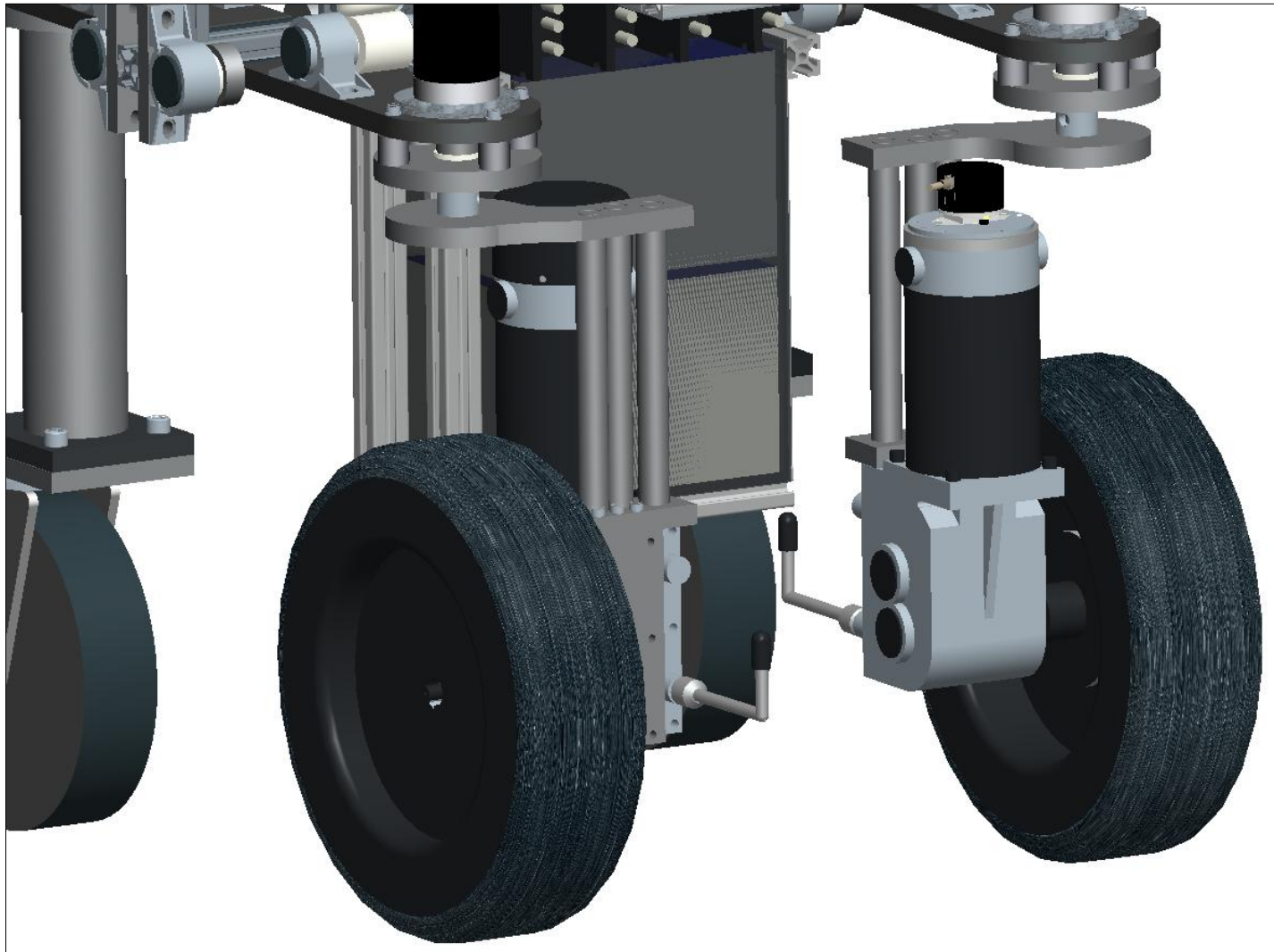

Driving Wheel Assembly (Back Left View)

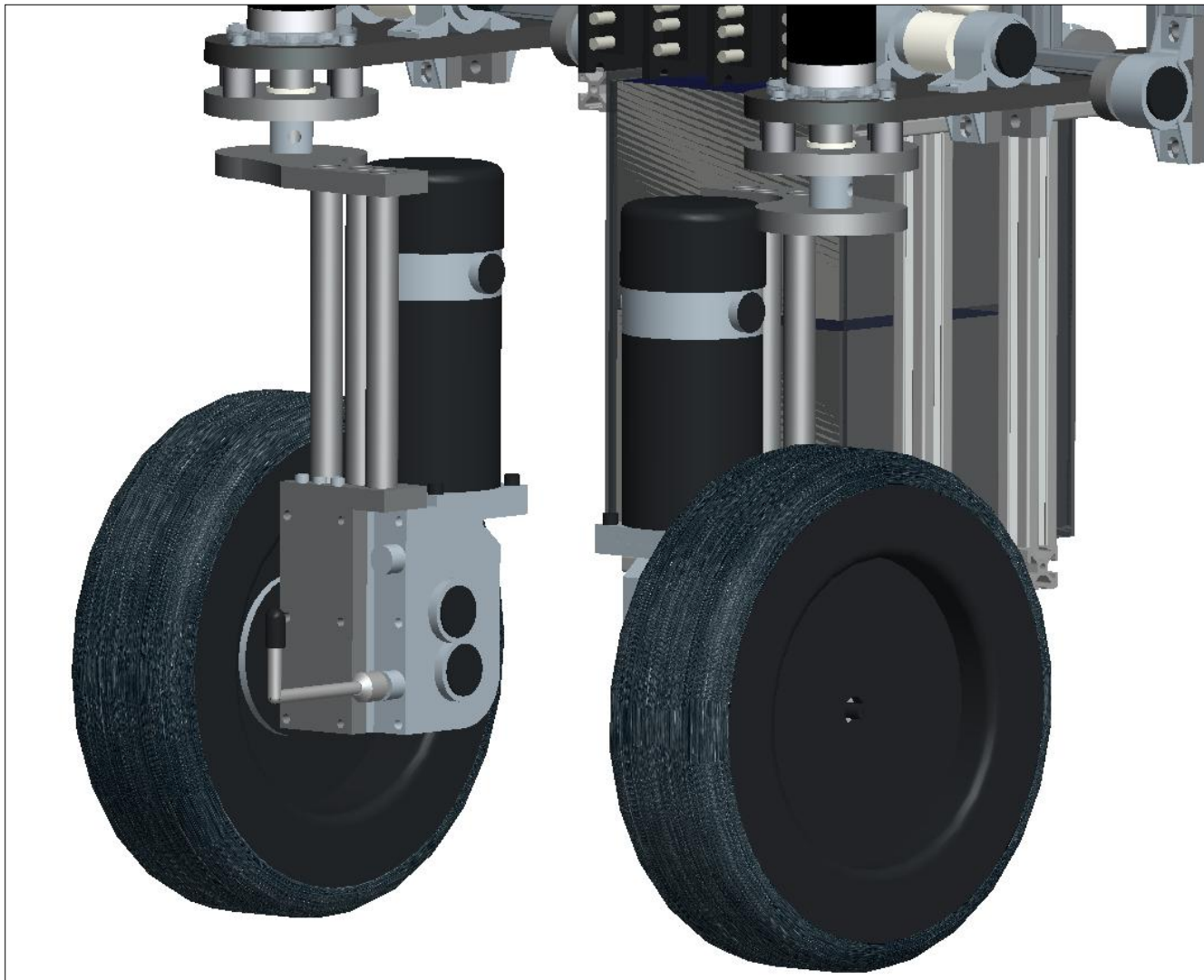

Driving Wheel Assembly (Back Right View)



Singular Driving Wheel & Mounting Assembly

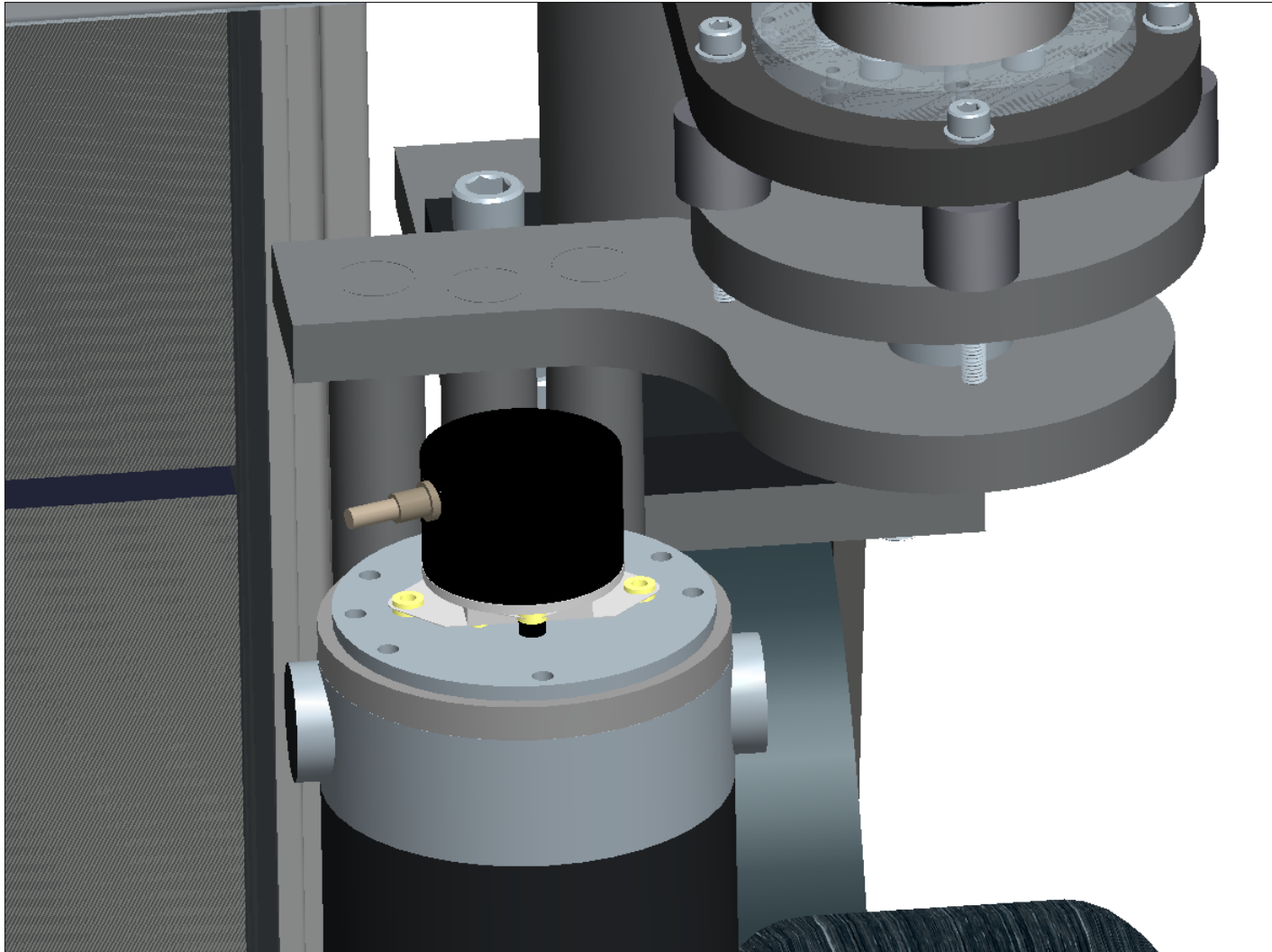

Steering Motor Mounting Arrangement

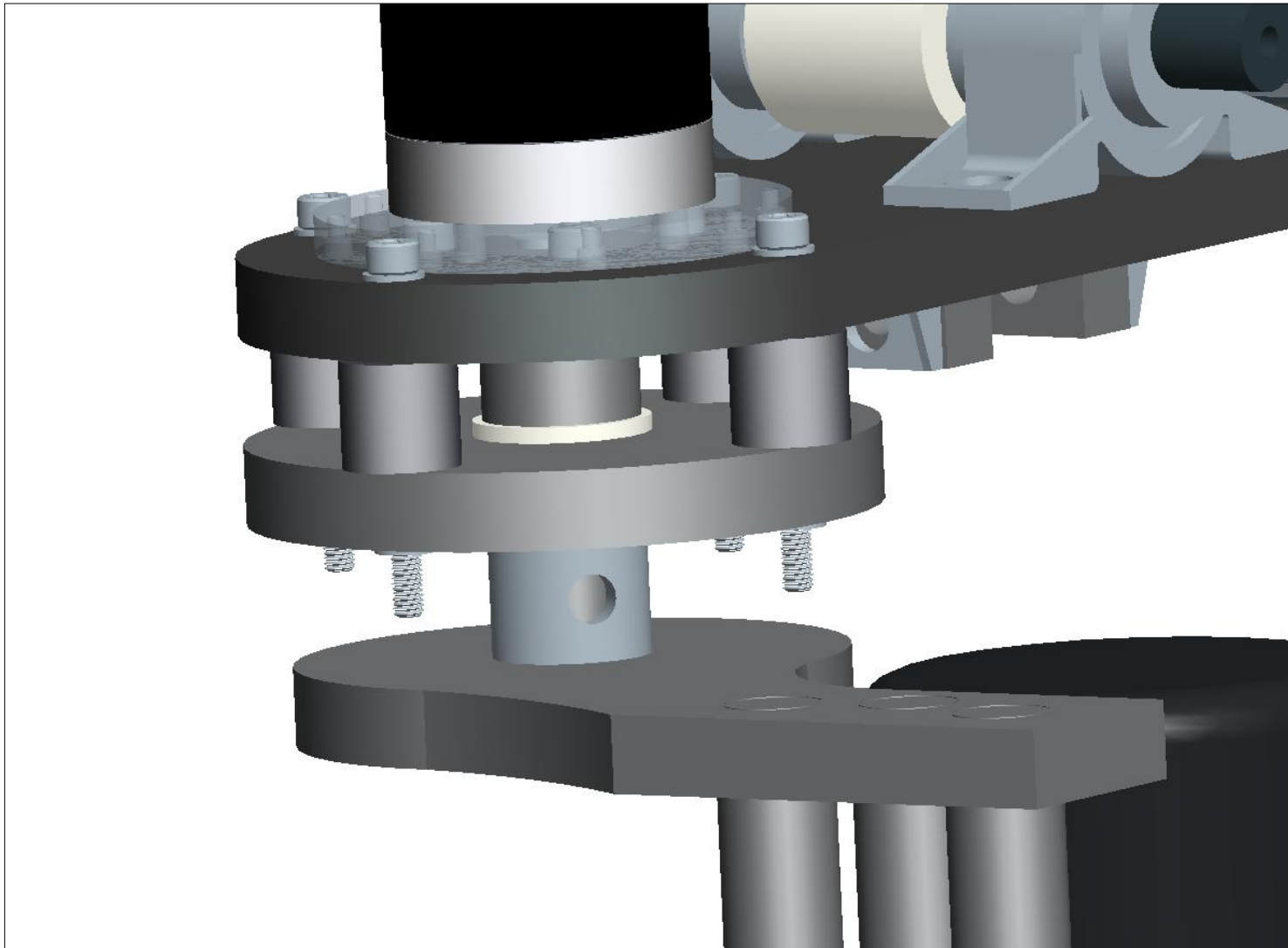

Thrust Bearing and Transfer Cup Implementation

Appendix B – Final Design Full Assembly

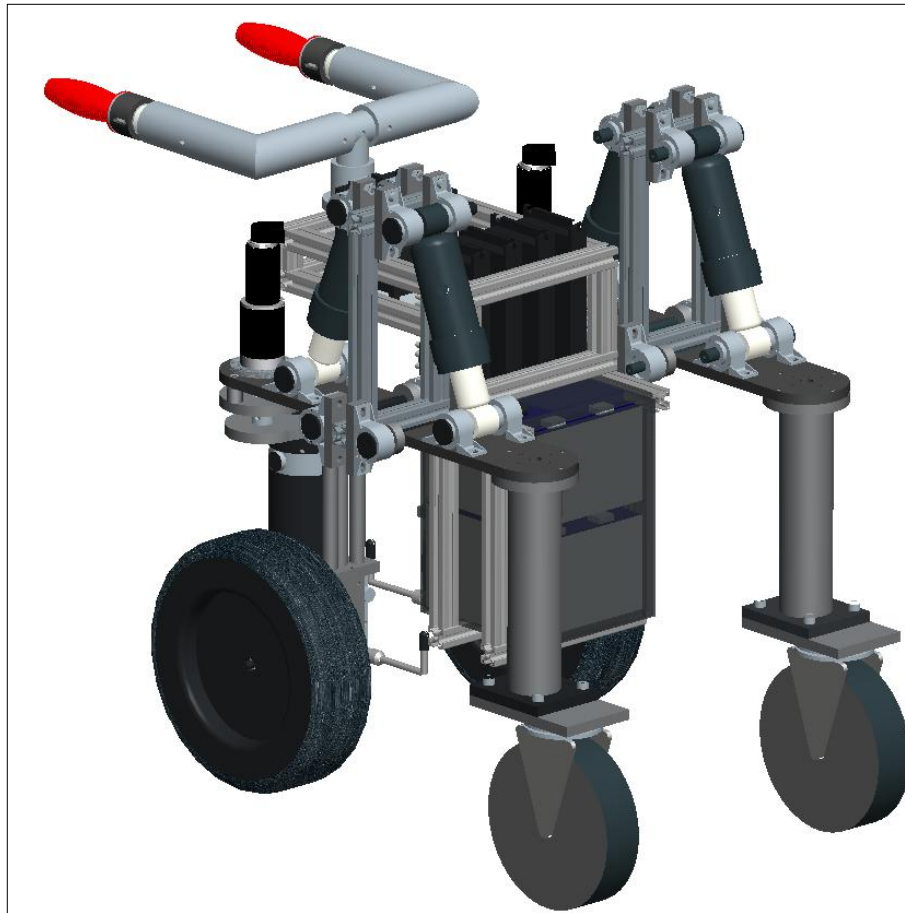

Front Left View

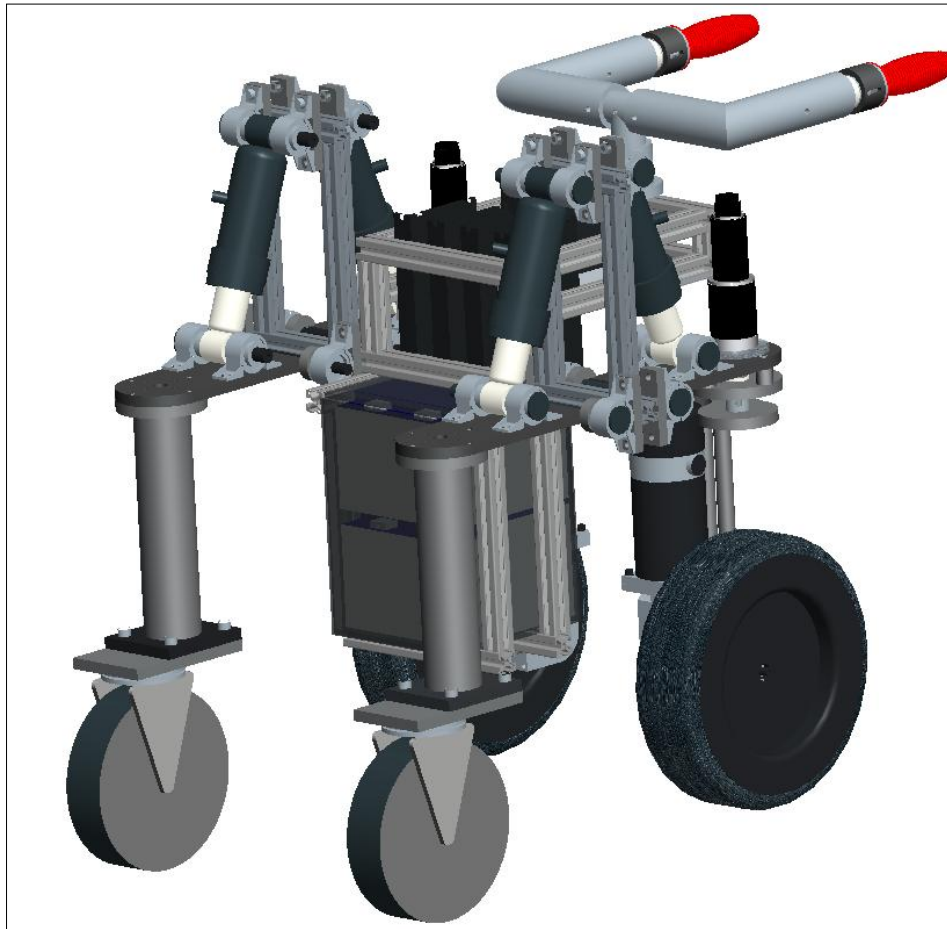

Front Right View

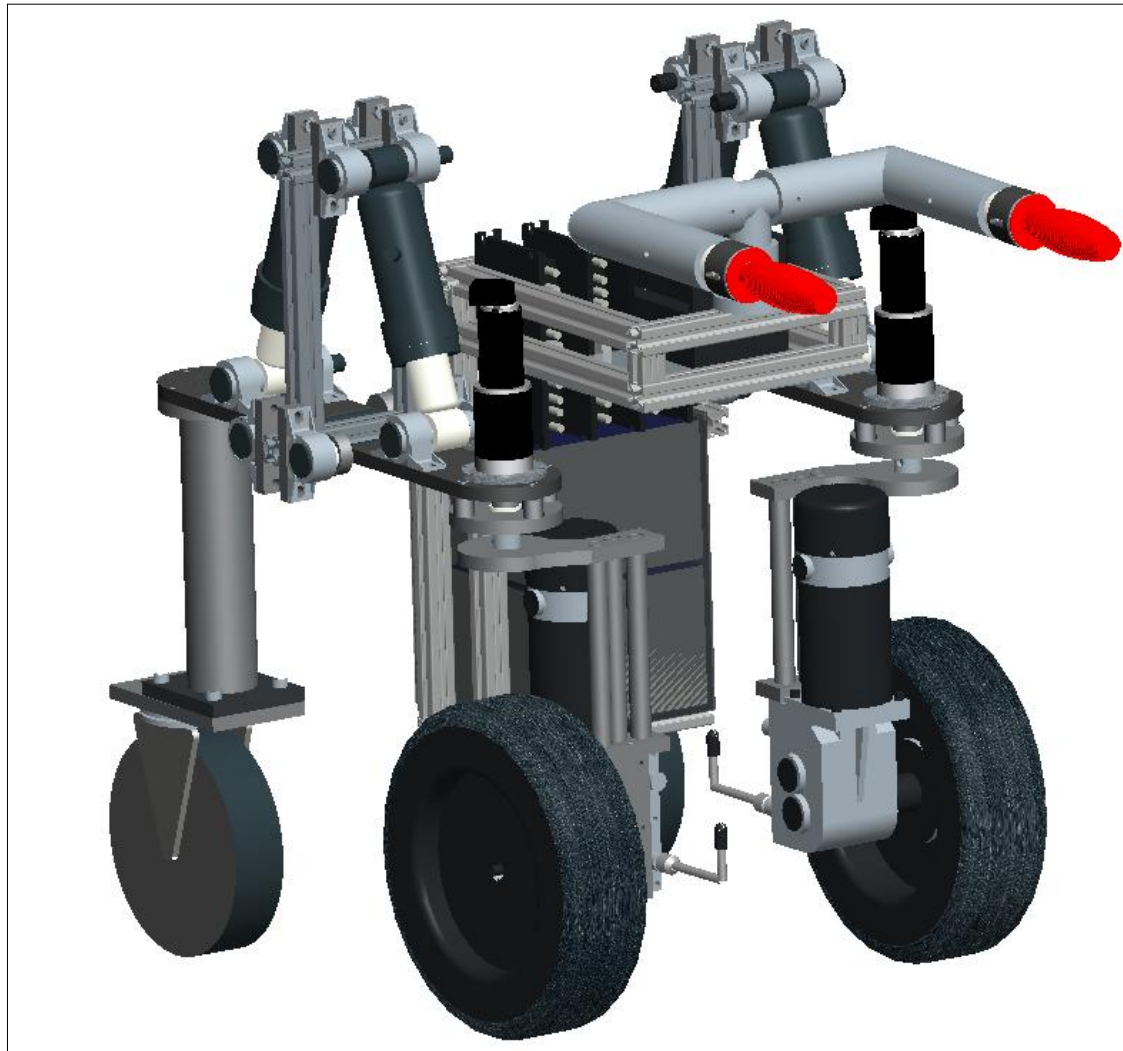

Back Left View

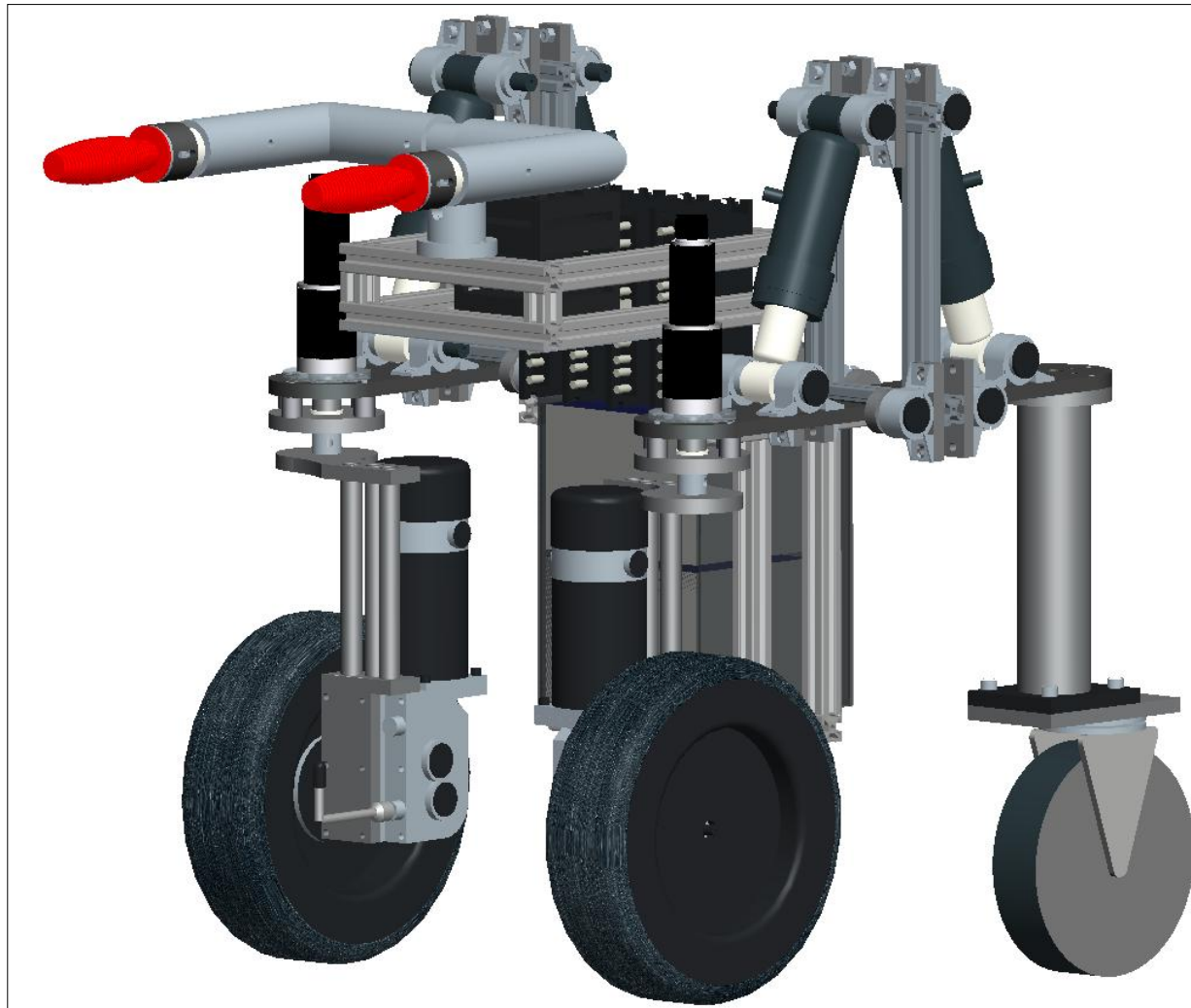

Back Right View

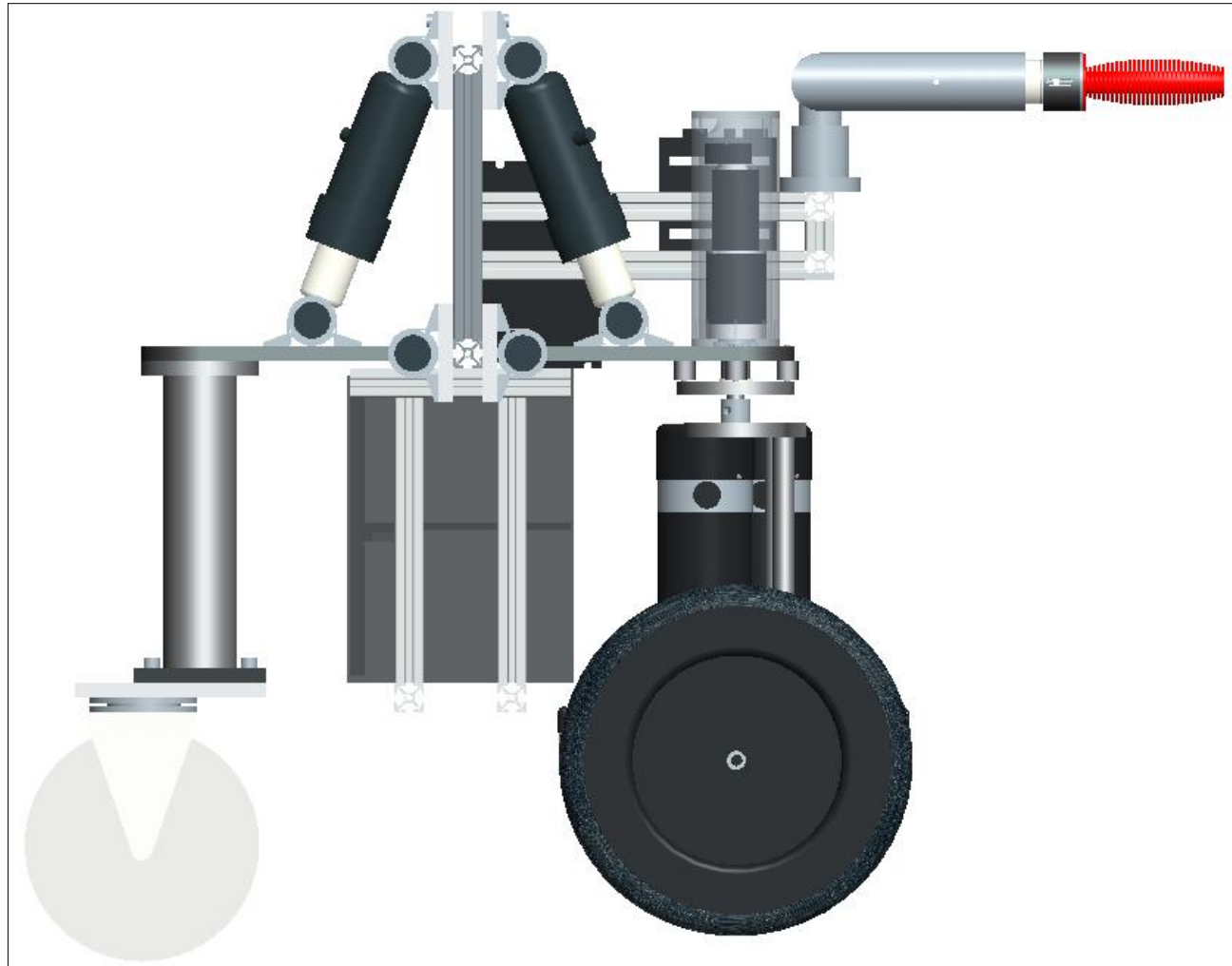

Left Side View

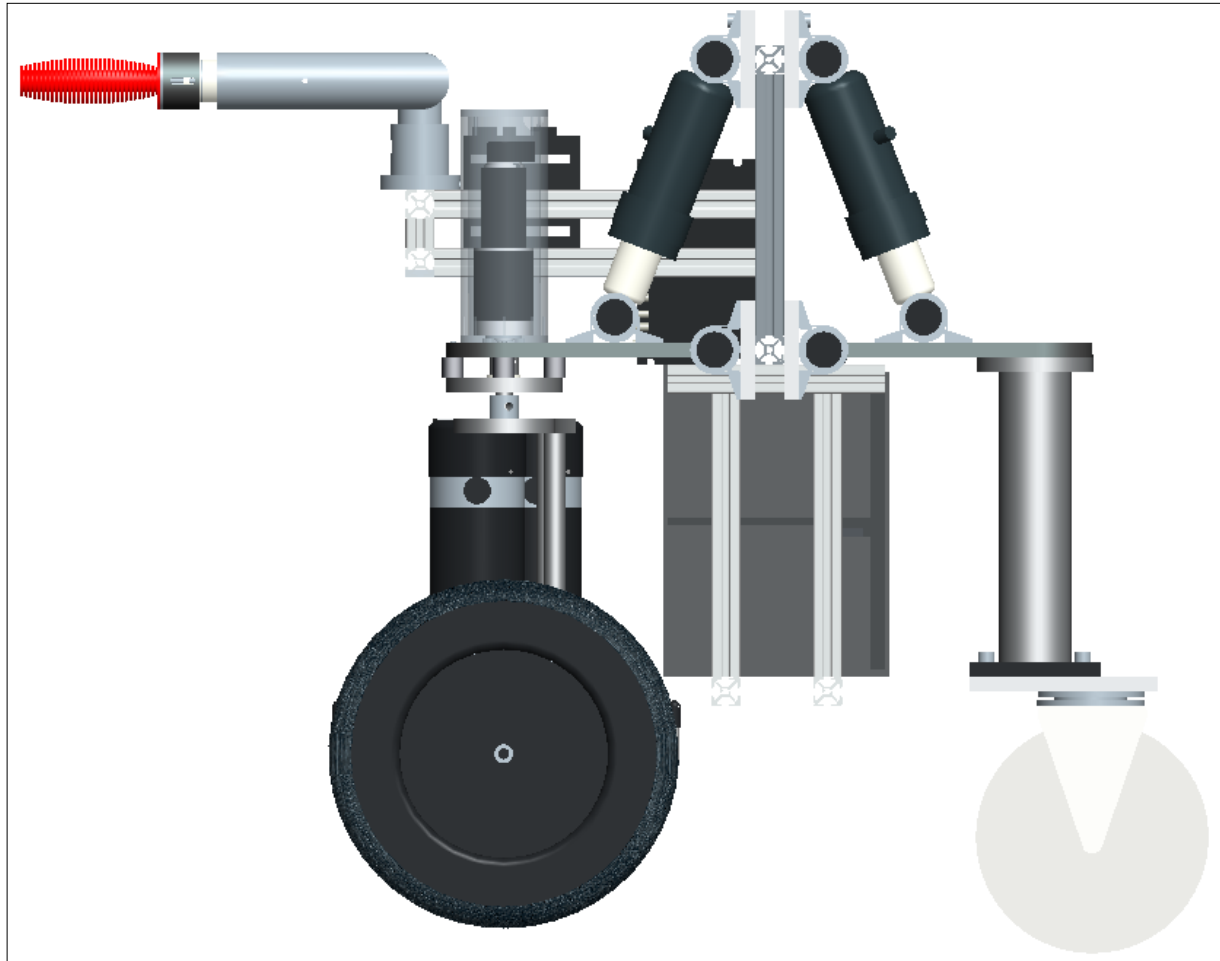

Right Side View

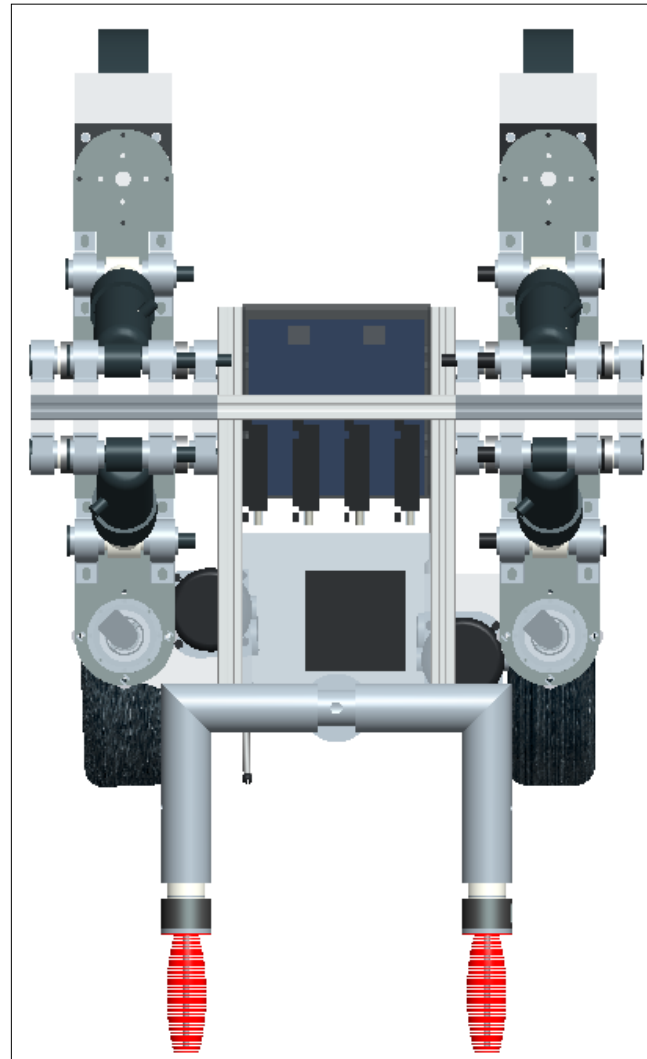

Top View

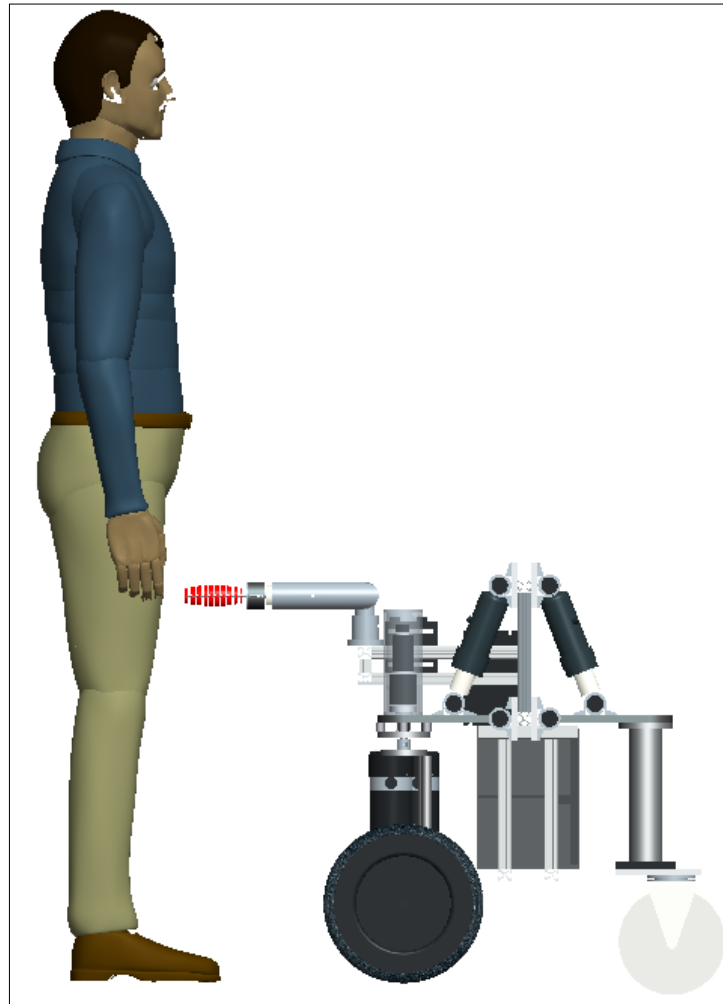

Right Side View with Human scale

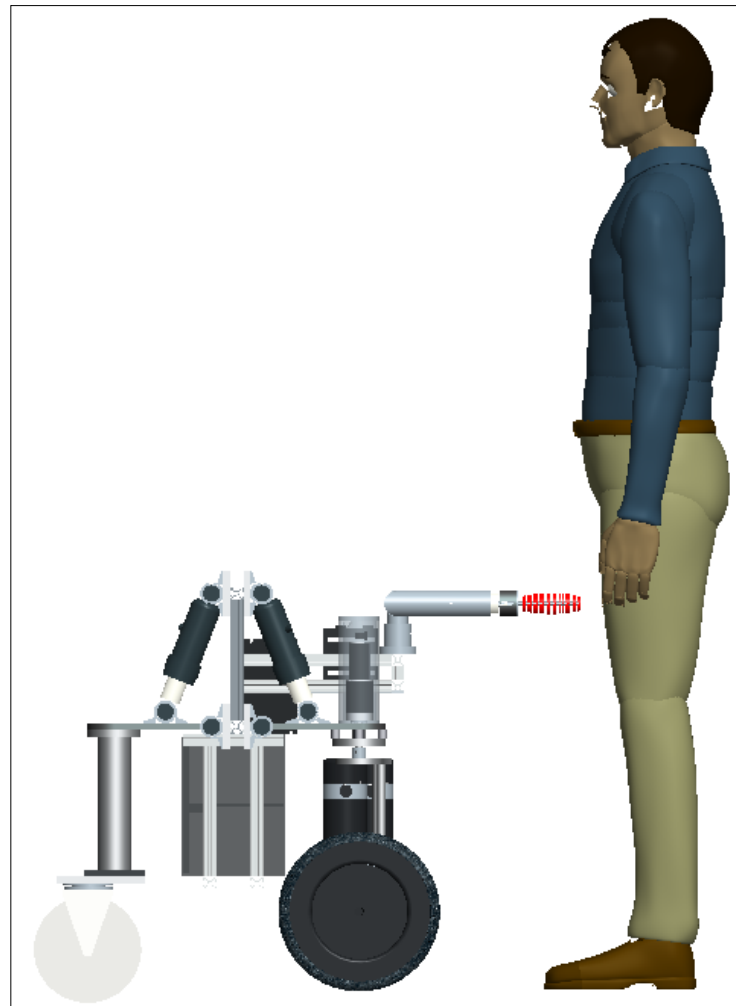

Left Side View with Human scale

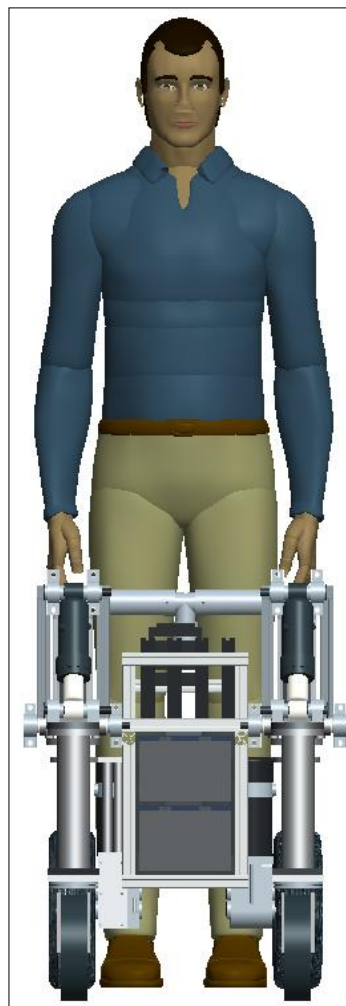

Front View with Human scale

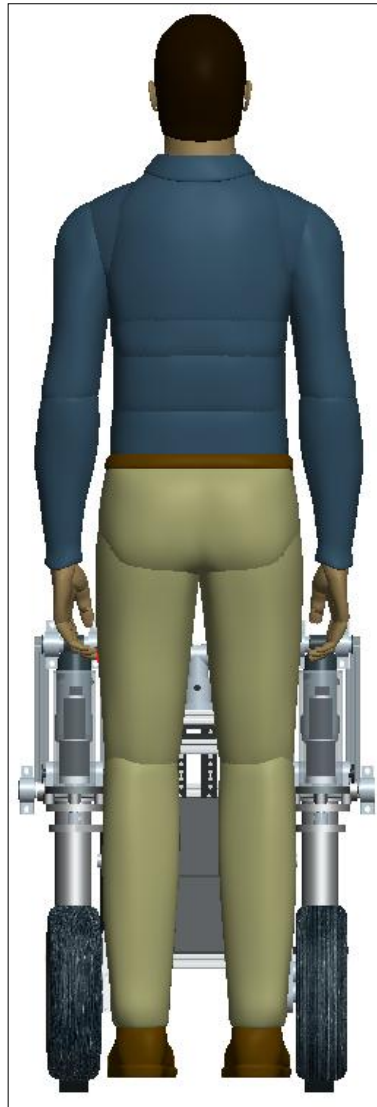

Back View with Human scale

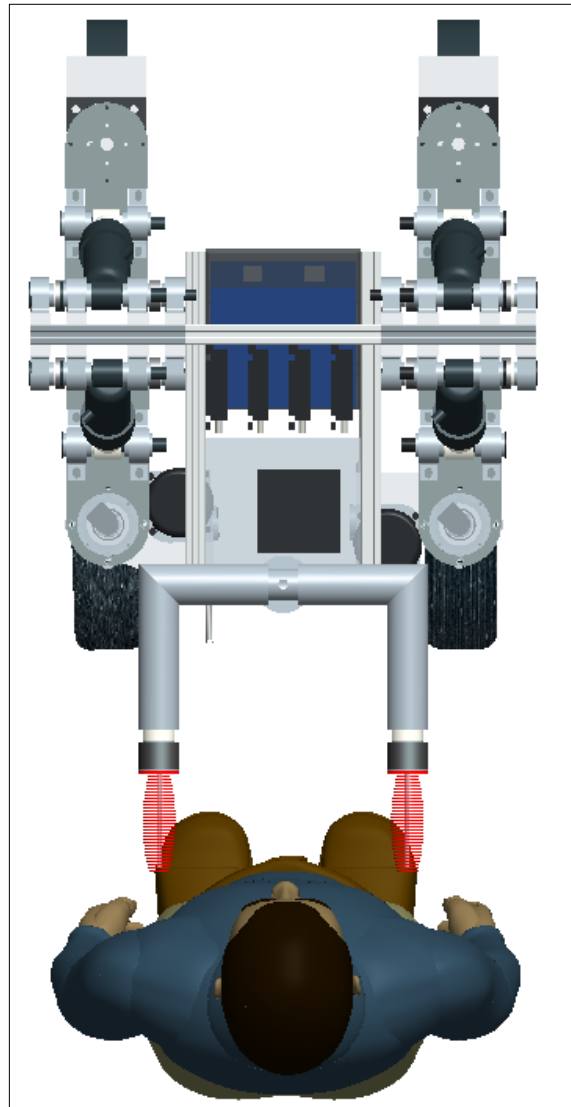

Top View with Human scale

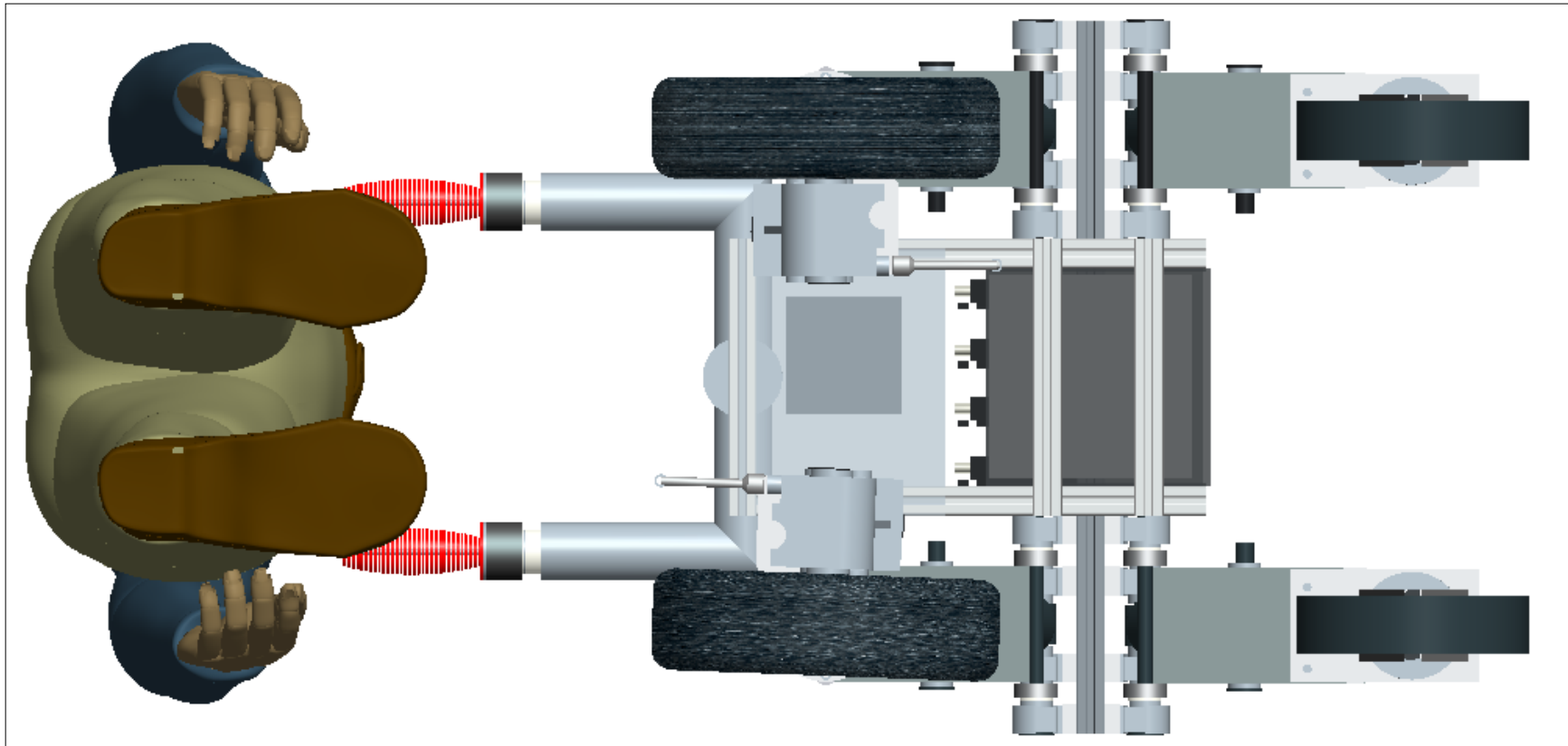

Bottom View with Human scale

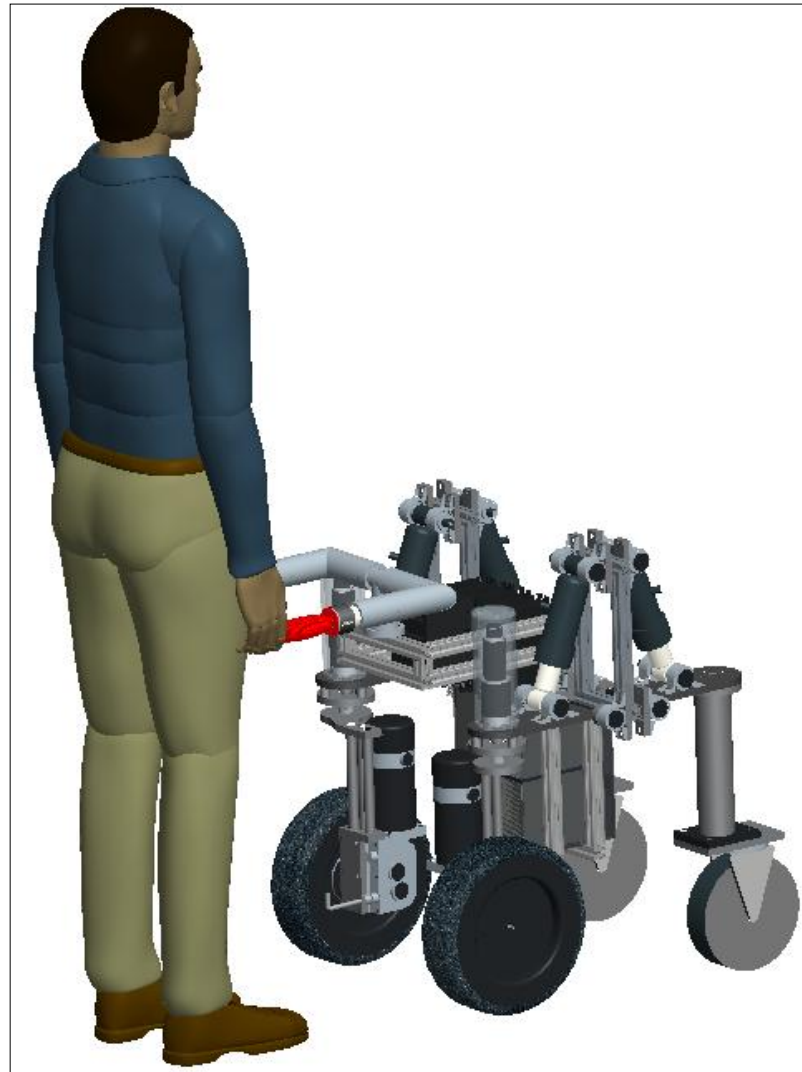

Back Right View with Human scale

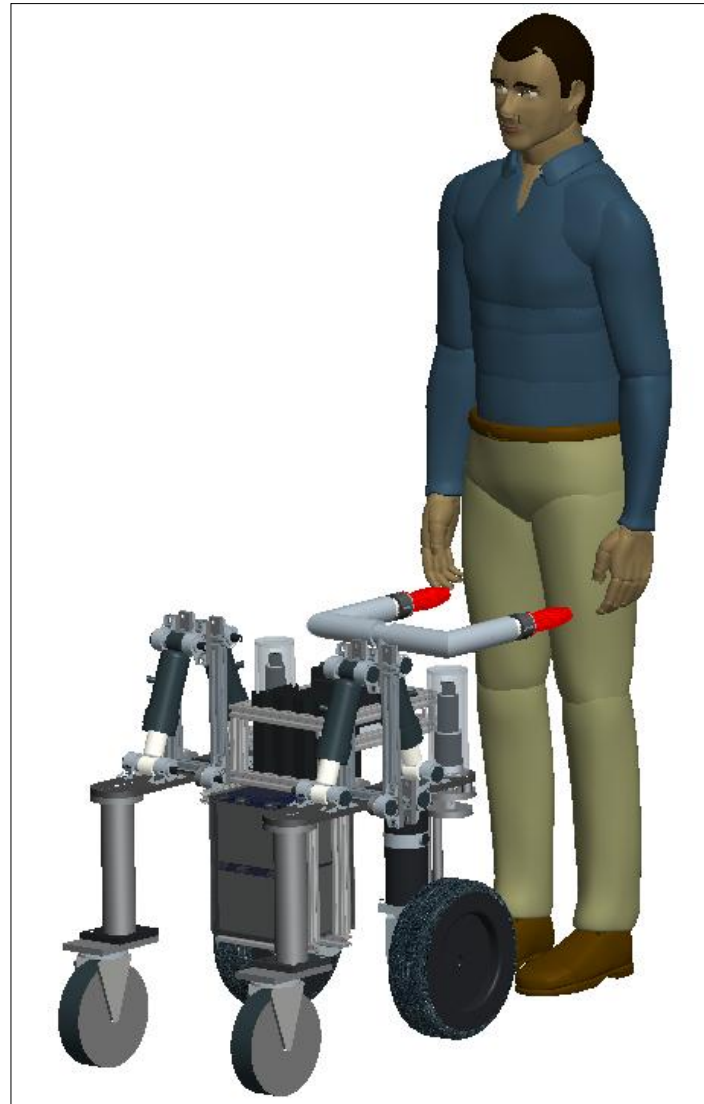

Front Right View with Human scale



Back Right View of Steering & Driving Motor arrangement



Back Right View of Walker Shock Displacement Prediction

Appendix C – MatLab Code for Air Shock Tests

```
x=[0 10 20 30 40 50]
y=[20 30 40 50 60 70 80 90 100 150 180 230 270 280 320 360]
z=[14 13.75 11.375 10.625 10.375 10.25 9.875 9.625 9.375 9.375 9.375 9.375 9.375 9.375 9.375 9.375;
14 14 14 13.875 13.875 12.875 12.875 12.875 11.75 10.625 10.25 9.625 9.375 9.375 9.375 9.375;
14 14 14 14 14 14 14 14 13.29167 12.58333 11.875 11.125 10.8125 10.5 10.125 9.75;
14 14 14 14 14 14 14 14 13.91667 13.83333 13.75 12.625 11.5 11.20833 10.91667 10.625;
14 14 14 14 14 14 14 14 14 14 14 13.75 13.5 13.25 13 12.75;
14 14 14 14 14 14 14 14 14 14 14 14 14 14 14 14 13.70833 13.41667 13.125];
surface(y,x,14-z)
axis on
```

Appendix D – Budget Summary

<u>Part</u>	<u>For</u>	<u>Number</u>	<u>Company</u>	<u>Cost/unit</u>	<u># Ordered</u>	<u>Total Cost</u>
Screws	connects top & bottom caps to enclosure	91251A112	McMaster	\$9.90	1	\$9.90
Screws	connects motor to plate	9125A173	McMaster	\$8.57	1	\$8.57
Screws	connects second thrust bearing to block	91251A219	McMaster	\$6.57	2	\$13.14
Nuts	goes with 91251A219	90725A030	McMaster	\$7.00	1	\$7.00
Washers	misc.	90965A160	McMaster	\$4.62	1	\$4.62
Screws	connects motor to bottom cap	91251A128	McMaster	\$8.57	1	\$8.57
Polycarbonate Sheet	steering motor top & bottom cap	8574K32	McMaster	\$30.50	1	\$30.50
Polyethylene Tube	steering motor outer enclosure	8705K82	McMaster	\$16.57	2	\$33.14
Mounted Ball Bearing	mounted bearing block	5913K610	McMaster	\$10.95	8	\$87.60
Steel Rectangular Bar	steering motor bottom plate	6554K321	McMaster	\$36.59	4	\$146.36
1.5in Steel Rod	swingarm thrust block	8927K411	McMaster	\$26.71	1	\$26.71
0.5in Steel Rod	swingarm bar & screw protector	8927K25	McMaster	\$20.69	1	\$20.69
Aluminum plate	steering motor rotation connect	8975K429	McMaster	\$19.05	1	\$19.05
Air Shocks	suspension	MA785	Monroe (Amazon)	\$63.91	2	\$127.82
12V Battery	battery	70115690	Power Sonic (Allied)	\$116.20	2	\$232.40
Cord connector	battery connectors	70214358	Switchcraft (Allied)	\$10.70	10	\$107.00
6 terminal connector	battery connectors	70152859	Cinch (Allied)	\$1.84	5	\$9.20
Cap	battery connectors	70214577	Switchcraft (Allied)	\$1.09	10	\$10.90
Panel connector	battery connectors	70214373	Switchcraft (Allied)	\$6.78	10	\$67.80
4 terminal connector	battery connectors	70152857	Cinch (Allied)	\$1.34	5	\$6.70
Barrier terminal block	battery connectors	70152946	Cinch (Allied)	\$0.25	20	\$5.00
Magnetic encoder	driving motor control	MPE-3	Eclipse Scientific	\$51.44	2	\$102.87
magnets	driving motor control		Eclipse Scientific	\$1.22	5	\$6.08
shipping	shipping		Eclipse Scientific	\$100.00	1	\$100.00
10K mono sliding taper pot	electronics	Pot10KBMono	Futurlec	\$0.45	10	\$4.50
10k sliding taper pot	electronics	pot10kbslide	Futurlec	\$1.30	5	\$6.50
10k stereo sliding taper pot	electronics	pot10kbstereo	Futurlec	\$0.55	5	\$2.75
grn automotive switch w/ lamp	electronics	rautogrlamp	Futurlec	\$0.75	5	\$3.75
red automotive switch w/ lamp	electronics	rautoredlamp	Futurlec	\$0.75	5	\$3.75
shipping	shipping		Futurlec	\$4.00	1	\$4.00
4600rpm motors & tires	driving motor & driving wheels	280800396868	eBay	\$374.99	1	\$374.99
shipping	shipping		eBay	\$49.99	1	\$49.99
Al 3/16in rod	handles	8974K29	McMaster	\$4.13	1	\$4.13

Al 7/8in rod	handles	8974K123	McMaster	\$15.54	1	\$15.54
Screws	handles	91251A537	McMaster	\$12.88	1	\$12.88
Al 2in tube	handles	9056K136	McMaster	\$99.74	1	\$99.74
Al 1.5in rod	handles	8974K41	McMaster	\$63.88	1	\$63.88
Al 1.5in tube	handles	9056K273	McMaster	\$43.38	1	\$43.38
Al 1in rod	handles	8974K133	McMaster	\$19.34	1	\$19.34
Grips	handles	97045K27	McMaster	\$11.96	1	\$11.96
48in spring	handles	9435K119	McMaster	\$8.68	1	\$8.68
42in spring	handles	9435K93	McMaster	\$6.50	1	\$6.50
Music wire spring	handles	9434K152	McMaster	\$5.11	1	\$5.11
Set screws	handles	92313A537	McMaster	\$4.63	1	\$4.63
Washers	handles	96765A160	McMaster	\$6.93	1	\$6.93
Screws	handles	91251A011	McMaster	\$6.10	4	\$24.40
Washers	handles	96765A140	McMaster	\$6.11	1	\$6.11
Maxon motor	steering motor		Maxon	\$750.00	2	\$1,500.00
shipping	shipping		Maxon	\$50.00	1	\$50.00
Nice Bearings	everything	SKF-9060	Reid	\$3.51	30	\$105.30
Mounted Ball Bearing	mounted bearing block	5913K620	McMaster	\$10.95	17	\$186.15
Mounted Ball Bearing	mounted bearing block	5913K610	McMaster	\$10.95	1	\$10.95
Stl. Stl. Rod	motor shaft connection	89535K371	McMaster	\$19.88	1	\$19.88
Screws	Secondary Bearing Block Steering Motor	92290a268	McMaster	\$4.65	1	\$4.65
Screws	Steering Motor Connection to Bottom Cap	92855A516	McMaster	\$7.23	1	\$7.23
Screws	Steering Motor Connection to Base Plate	92290A254	McMaster	\$11.80	1	\$11.80
Locking Hex Nuts	Holds steering motor on	94205A240	McMaster	\$6.09	1	\$6.09
Screws	Bearing Block Attach	91251A383	McMaster	\$5.89	2	\$11.78
locking hex nuts	Bearing Block Attach	97135A225	McMaster	\$3.88	2	\$7.76
Screws	Hold Swing Bars in Place	91251A537	McMaster	12.88	1	\$12.88
Caster Wheel	Ezy-Roll Casters	2652T52	McMaster	\$33.38	4	\$133.52
Screws	Screw for Casters	91251A426	McMaster	8.87	1	\$8.87
Locking Hex Nuts	Locking Hex Nuts	97135A235	McMaster	\$4.14	1	\$4.14
Screws	Connection to Upper Caster Leg	91290A256	McMaster	\$12.30	1	\$12.30
Screws	Driving Motor Lower Connector Plates	91290A242	McMaster	\$7.95	1	\$7.95
Corner Brackets	T-slotted connections	47065T223	McMaster	\$3.98	50	\$199.00
Connection Screws	T-slotted connections	47065T142	McMaster	\$2.30	25	\$57.50
Connection Bolt	T-slotted connections	47065T233	McMaster	\$1.60	20	\$32.00
0.5in Al rod	Shock shafts	8974K33	McMaster	\$15.04	1	\$15.04
Pressure Gauges	Shock setting	4089K14	McMaster	\$9.20	2	\$18.40
End Fasteners	80/20 polycarbonate	47065T142	McMaster	\$2.30	5	\$11.50
Bolt Fasteners	80/20 polycarbonate	47065T233	McMaster	\$1.60	10	\$16.00
Mounted Ball Bearing	Shock mounts	5913K610	McMaster	\$10.95	8	\$87.60

Spent: \$4,513.35

Budget: \$5,000.00

Left: \$486.65

(10.0) Engineering Drawings

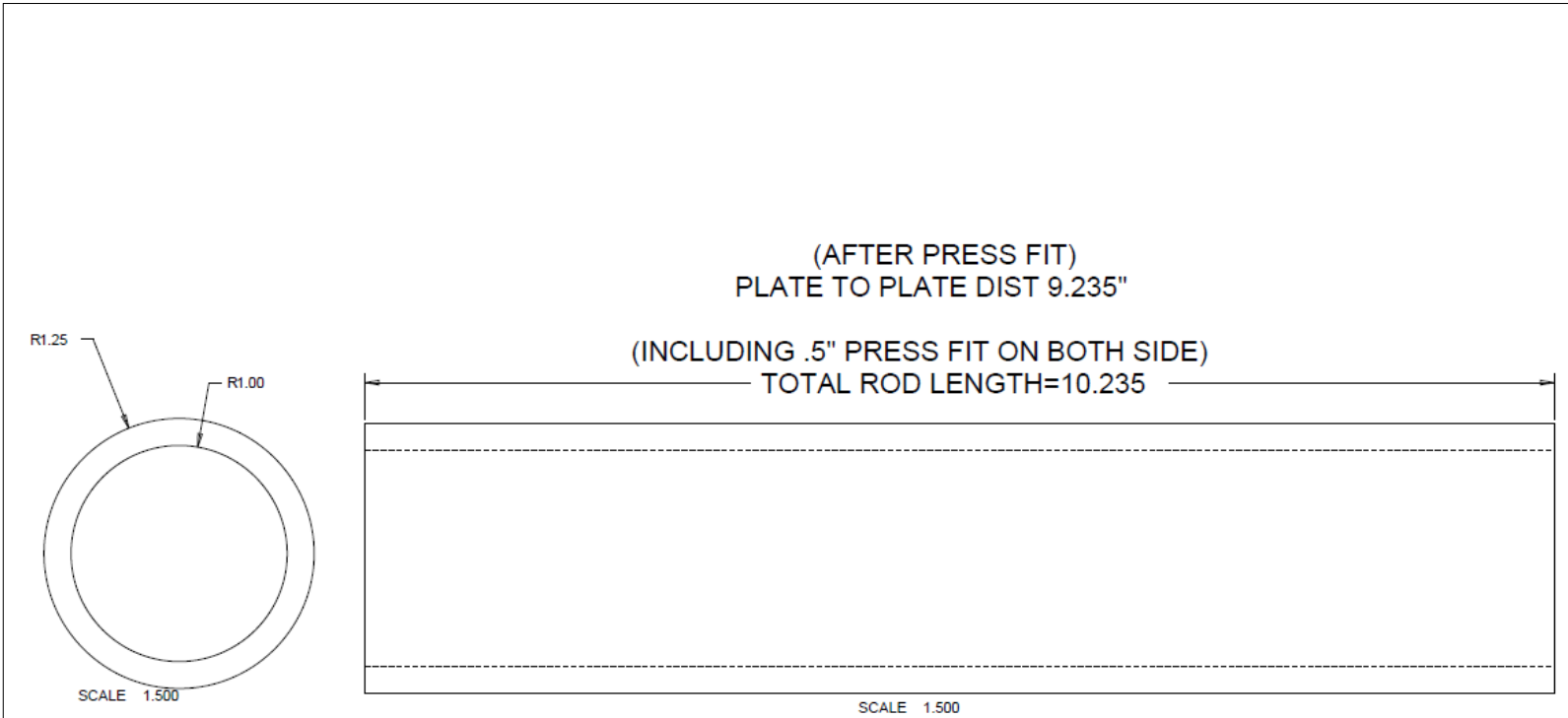

Assembly: 1
 Part: 2 of 3
 Material: 2.5" OD AL Tube (.25 Thick)
 Quantity: 2
 DIM in INCHES unless noted

ADDITIONAL PARTS REQUIRED FOR ASSEMBLY:	Senior Design - Team # 17 Outdoor Robotic Walker
	PART: <code>caster_leg</code>
	Additional Info:
	DATE: JANUARY 31st, 2012
http://eng.fsu.edu/me/senior_design/2012/team17/	

DRILL THRU
FOR 3/8"-24 SCREW
Ø .39"
TYP 4 PLACES

DRILL THRU Ø 2.5"
THE caster_leg (2.5" OD)
WILL BE PRESS FIT TILL
FLUSH AND WELDED TO
THIS PLATE

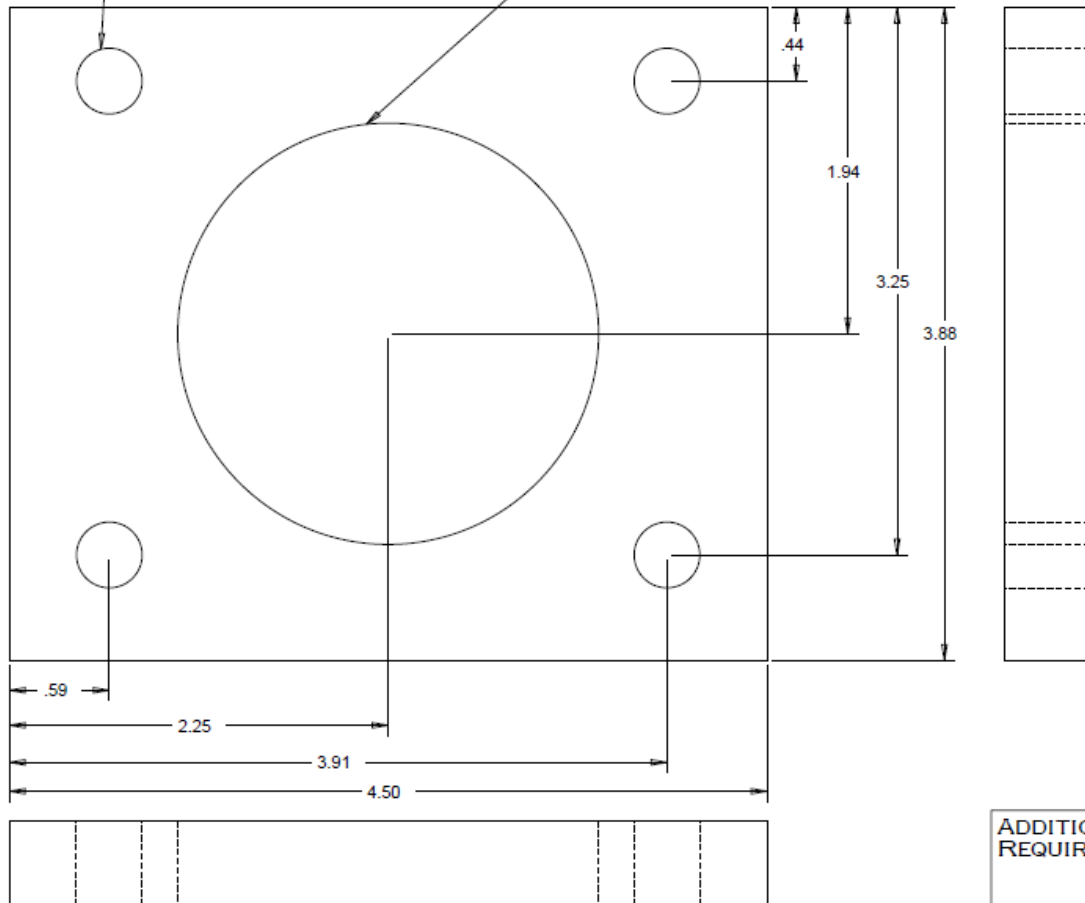

Assembly: 1
Part: 3 of 3
Material: 0.5" Aluminum Plate
Quantity: 2
DIM in INCHES unless noted

ADDITIONAL PARTS REQUIRED FOR ASSEMBLY:	Senior Design - Team # 17 Outdoor Robotic Walker
	PART: CASTER_LEG_LOWER_ATTACHMENT
	Additional Info:
	DATE: JANUARY 31st, 2012
http://eng.fsu.edu/me/senior_design/2012/team17/	

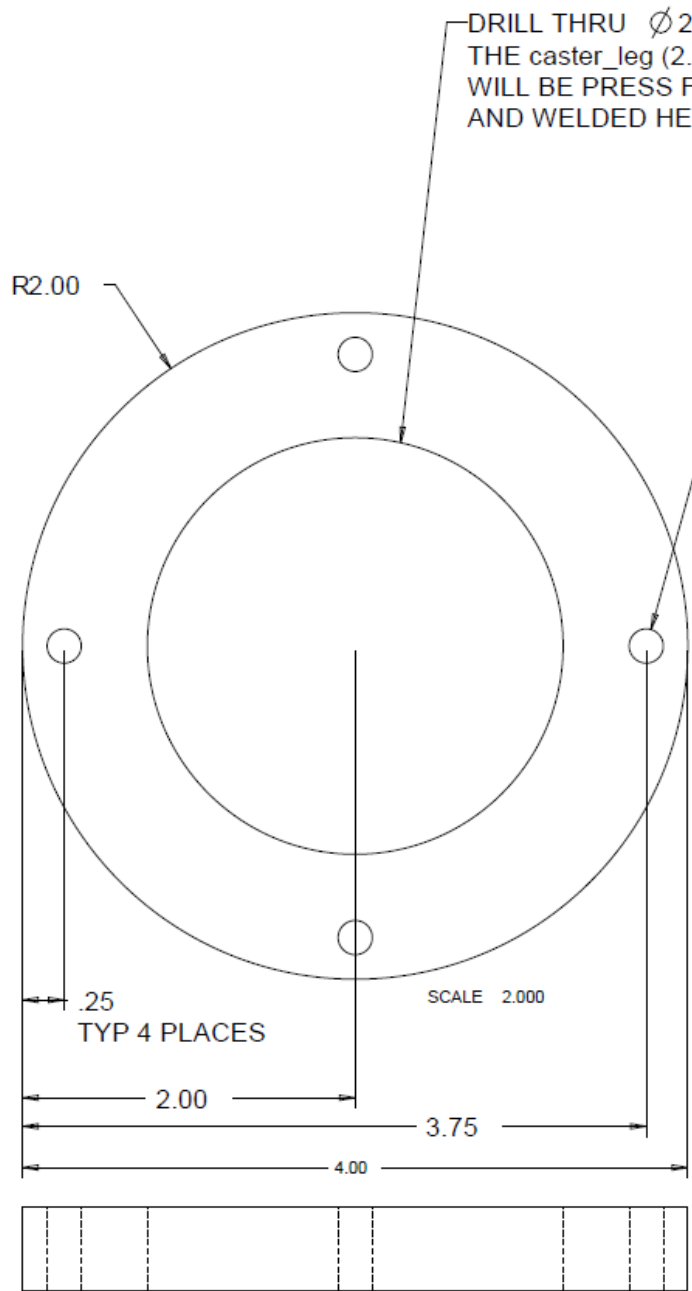

Assembly: 1
Part: 1 of 3
Material: 0.5" Aluminum Plate
Quantity: 2
DIM in INCHES unless noted

ADDITIONAL PARTS REQUIRED FOR ASSEMBLY:	Senior Design - Team # 17 Outdoor Robotic Walker
	PART: CASTER_LEG_UPPER_ATTACHMENT
	Additional Info:
	DATE: JANUARY 31st, 2012
http://eng.fsu.edu/me/senior_design/2012/team17/	

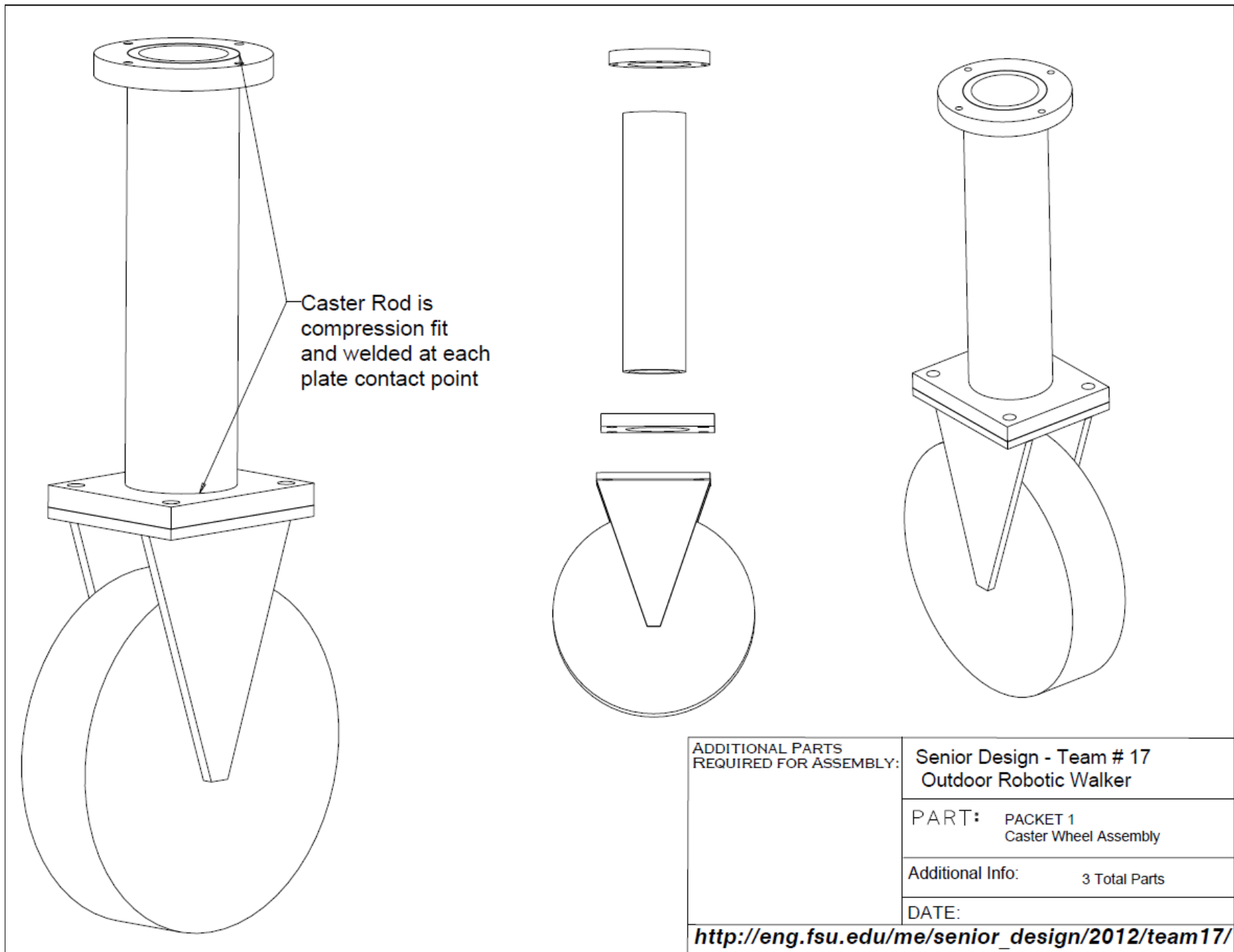

ADDITIONAL PARTS REQUIRED FOR ASSEMBLY:	Senior Design - Team # 17 Outdoor Robotic Walker
	PART: PACKET 1 Caster Wheel Assembly
	Additional Info: 3 Total Parts
	DATE:
http://eng.fsu.edu/me/senior_design/2012/team17/	

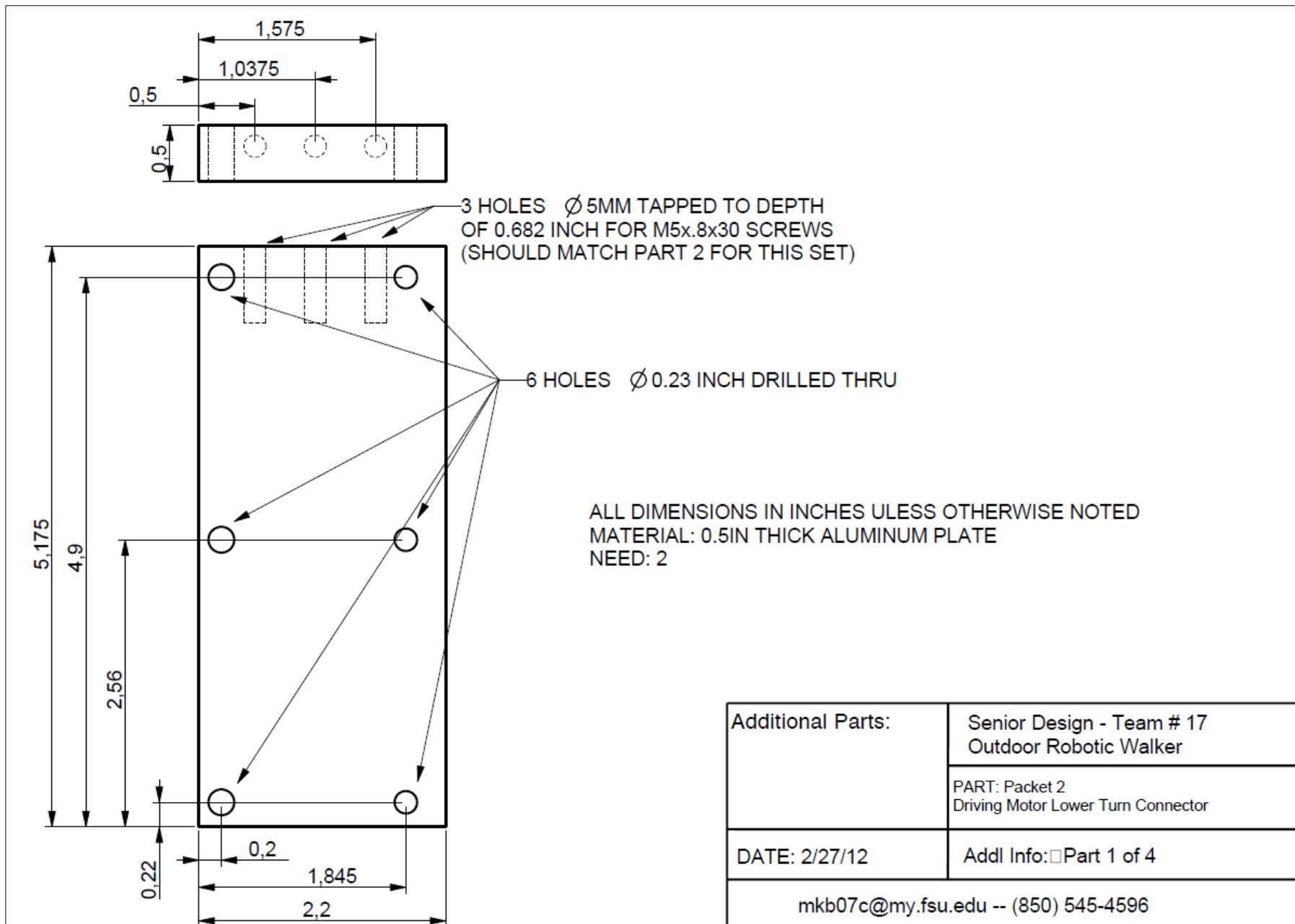

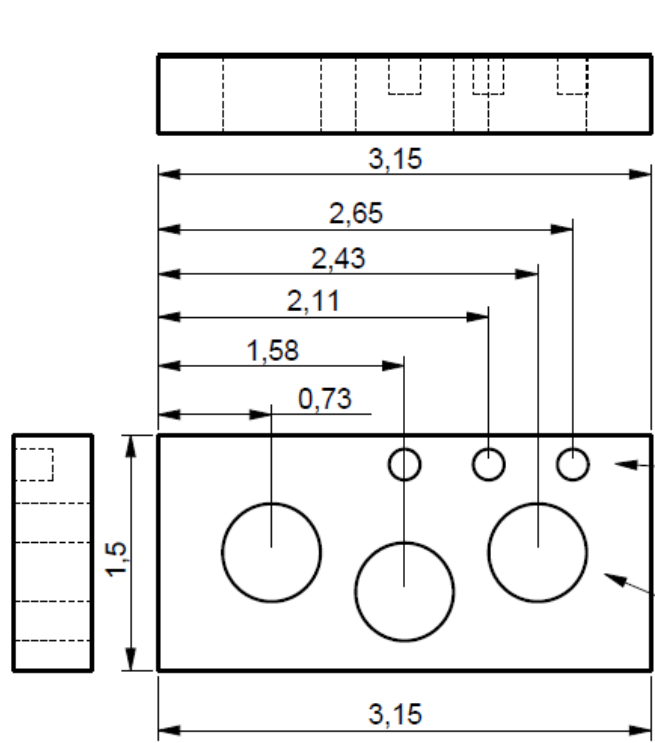

NOT ALL DIMENSIONS GIVEN
AS THIS PIECE WILL BE
WATERJETTED

3 HOLES \varnothing 5MM DRILLED THRU
FOR M5x0.8x30 SCREWS
(SHOULD MATCH PART 1 OF THIS SET)

3 HOLES \varnothing 5/8 INCH DRILLED THRU
ALUMINUM RODS (PART 3) TO BE PRESS FIT & WELDED IN HOLES
(SHOULD MATCH PART 4)

ALL DIMENSIONS IN INCHES ULESS OTHERWISE NOTED
MATERIAL: 0.5IN THICK ALUMINUM PLATE
NEED: 2

Additional Parts:	Senior Design - Team # 17 Outdoor Robotic Walker
	PART: Packet 2 Driving Motor Mid Turn Connector
DATE: 2/27/12	Addl Info: <input type="checkbox"/> Part 2 of 4
mkb07c@my.fsu.edu -- (850) 545-4596	

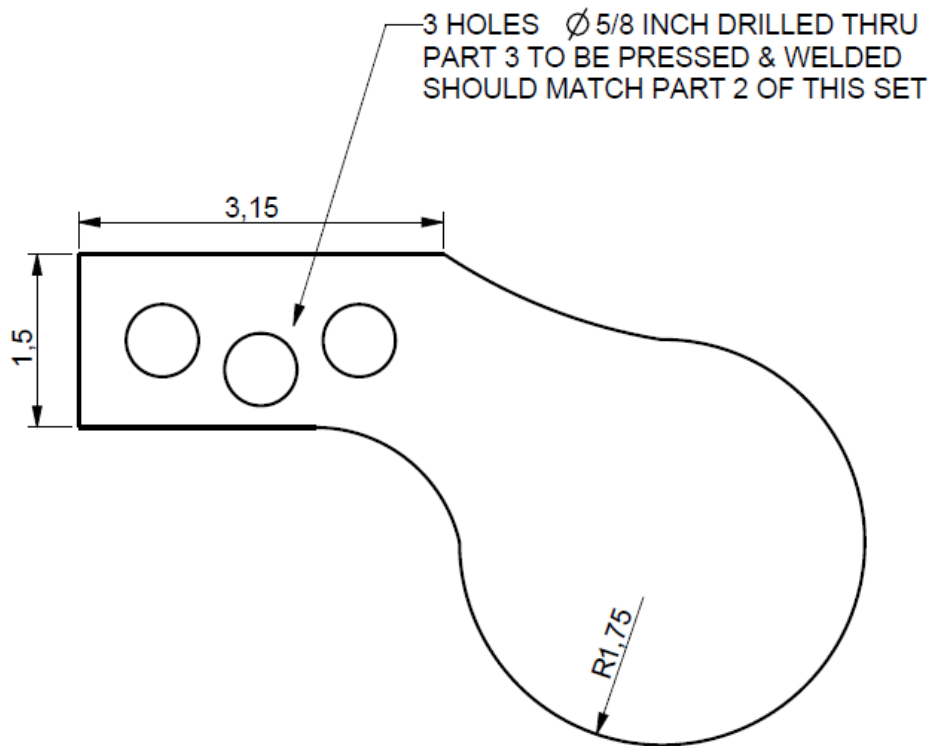

ALL DIMENSIONS IN INCHES
 MATERIAL: 0.5IN THICK ALUMINUM PLATE
 NEED: 2

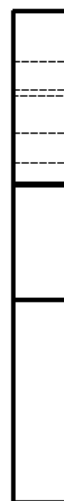

Additional Parts:	Senior Design - Team # 17 Outdoor Robotic Walker
	PART: Packet 2 Driving Motor Top Turn Connector
DATE: 2/27/12	Addl Info: <input type="checkbox"/> Part 4 of 4
mkb07c@my.fsu.edu -- (850) 545-4596	

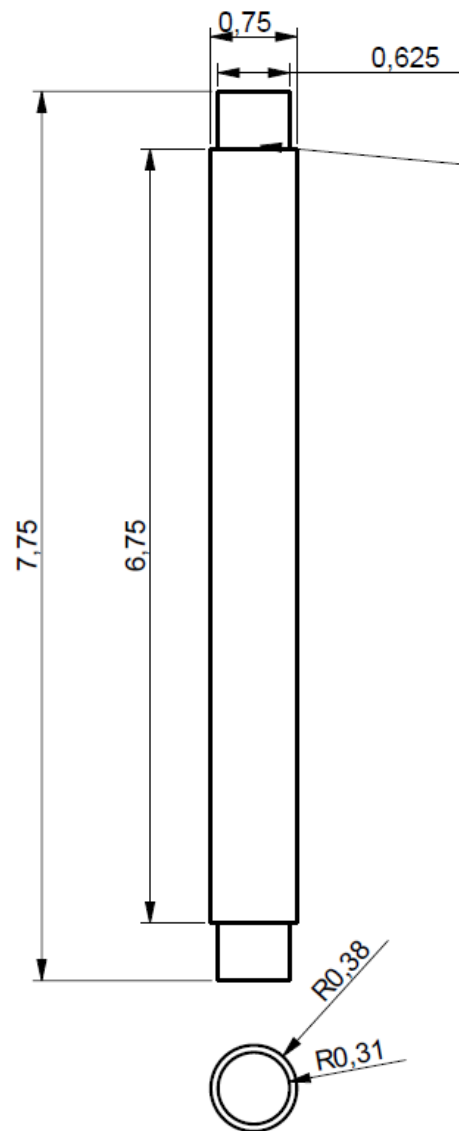

"PLATE TO PLATE" IS 6.75 INCH
 FULL ROD LENGTH IS 7.75 INCH
 CUT DOWN TO \varnothing 5/8 INCH ON BOTH ENDS 0.5 INCHES
 PRESS INTO & WELD TO PARTS 2 & 4 FROM THIS SET

ALL DIMENSIONS IN INCHES
 MATERIAL: \varnothing 0.75 INCH ALUMINUM ROD
 NEED: 6

Additional Parts:	Senior Design - Team # 17 Outdoor Robotic Walker
	PART: Packet 2 Driving Motor Upper Turn Connection Rods
DATE: 2/27/12	Addl Info: <input type="checkbox"/> Part 3 of 4
mkb07c@my.fsu.edu -- (850) 545-4596	

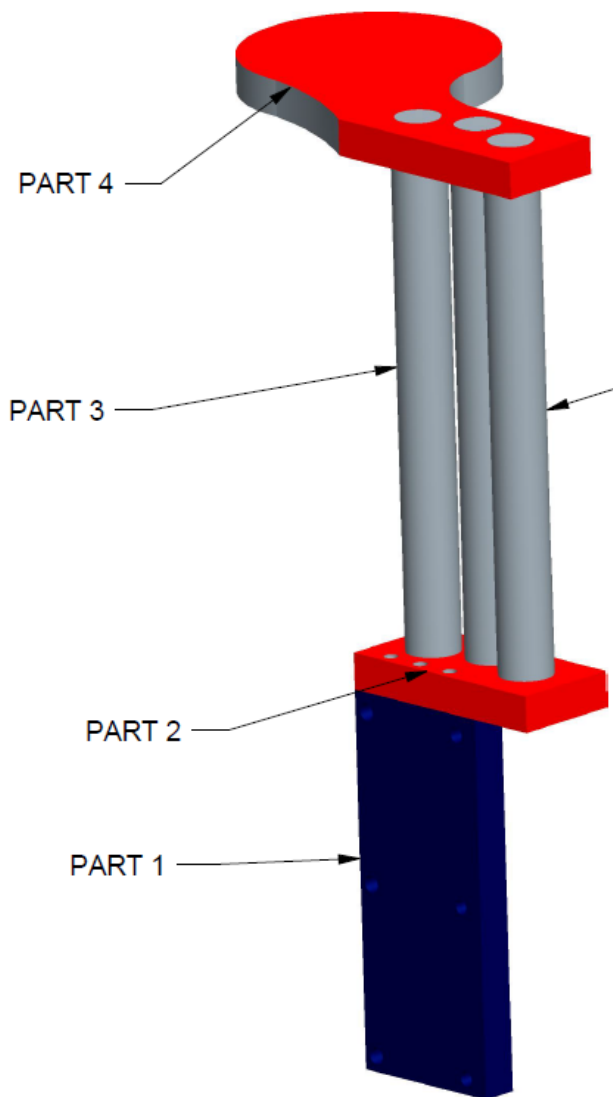
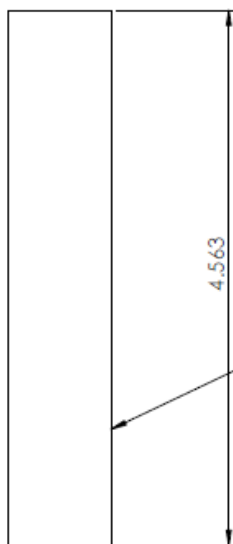
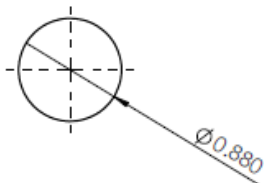
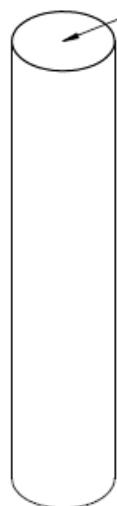

PLATE TO PLATE LENGTH 6.75 INCH
 ALL RODS \varnothing 0.75 INCH ALUMINUM WITH
 ENDS TO \varnothing 5/8 INCH TO FIT & WELD

Additional Parts:	Senior Design - Team # 17 Outdoor Robotic Walker
	PART: Packet 2 DRIVING WHEEL ASSEMBLY
DATE: 2/27/12	Addl Info: <input type="checkbox"/> 4 PARTS
mkb07c@my.fsu.edu -- (850) 545-4596	

Must be welded to Part #2



Length subject to change as necessary to fit handle

Quantity Needed: 2
 Raw Materials: 7/8 Inch Solid 6061 Rod
 Material Product Number: 8974K123
 Part Number: 1
 Page: 1 of 1

UNLESS OTHERWISE SPECIFIED: DIMENSIONS ARE IN MILLIMETERS SURFACE FINISH: TOLERANCES: LINEAR: ANGULAR:		FINISH:	DEBUR AND BREAK SHARP EDGES	DO NOT SCALE DRAWING	REVISION
DATE:	NAME:	SIGNATURE:	DATE:	TITLE:	
DESIGN:					
CHECK:					
APPROVE:					
MFG:					
D.A.					
Part 1 - Handle			MATERIAL:	PART NO.	8974K123

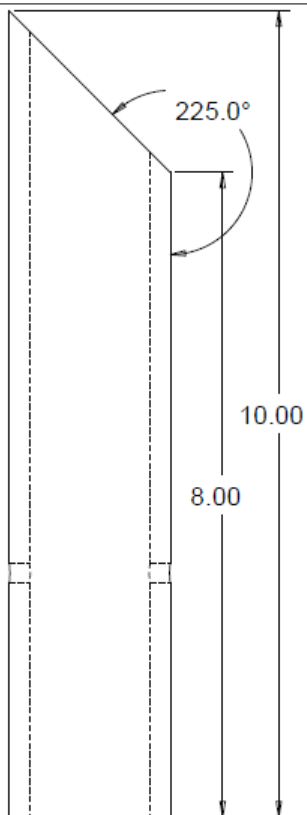

MUST BE WELDED TO PART handles_11
SO THAT THE TWO FORM A 90 DEG ELBOW

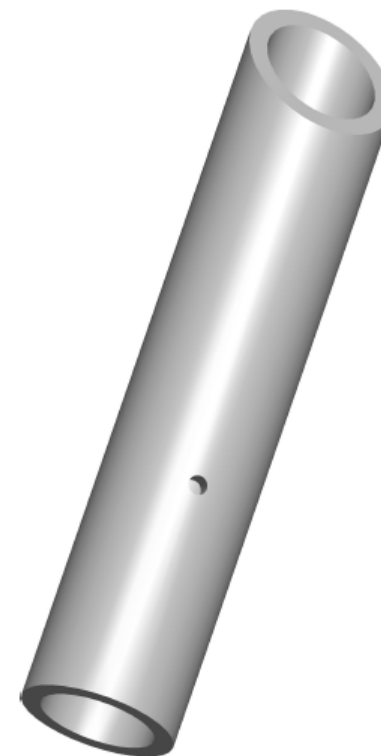

SCALE 1.000

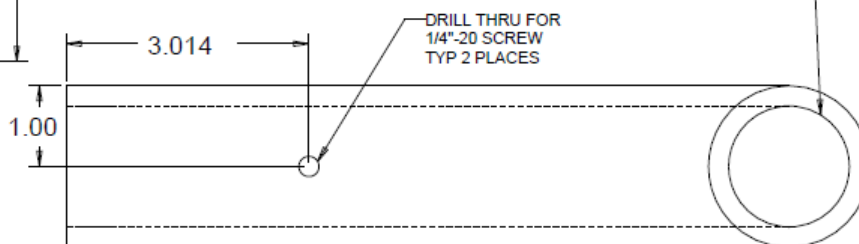
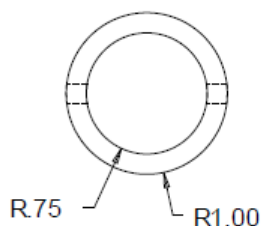

Material: 2" OD AL Tube (.25 Thick)
Quantity: 2
DIM in INCHES unless noted

ADDITIONAL PARTS
REQUIRED FOR ASSEMBLY:

Senior Design - Team # 17
Outdoor Robotic Walker

PART:
handles_10_outer_extension

Additional Info:

DATE: JANUARY 31st, 2012

http://eng.fsu.edu/me/senior_design/2012/team17/

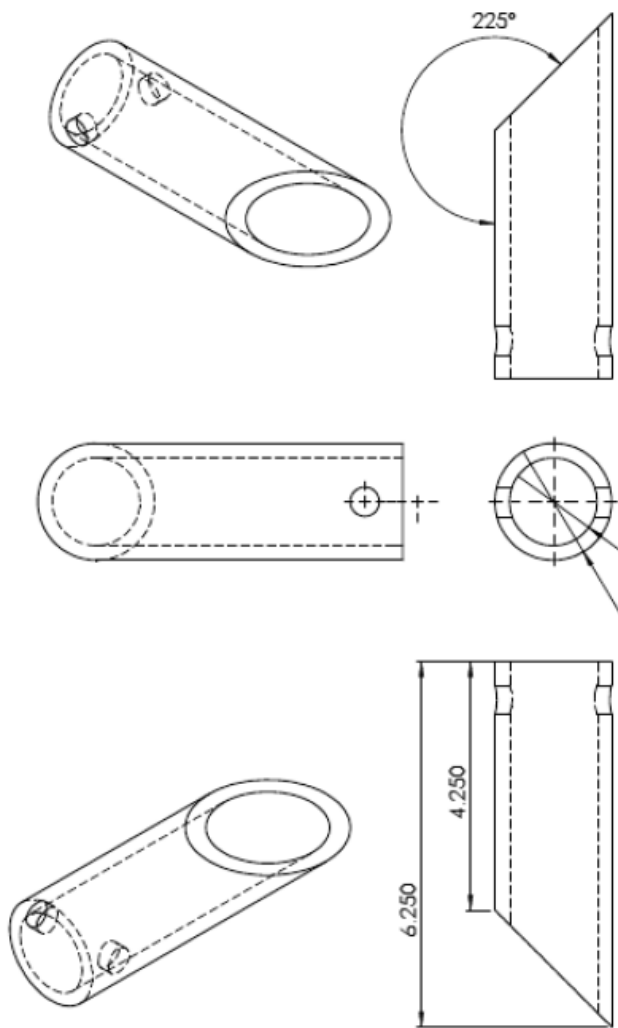

Quantity Needed: 2
 Raw Materials: 2" OD 6061 Tube
 Material Product Number: 9056K136
 Part Number: 11
 Page: 1 of 1

DRILL THRU FOR
 1/2"-20 SCREW
 TYP 2 PLACES

**MUST BE WELDED TO PIECE 10 TO FORM
 A 90 DEGREE ELBOW**

UNLESS OTHERWISE SPECIFIED: DIMENSIONS ARE IN MILLIMETERS SURFACE FINISH: TOLERANCES: LINEAR: ANGULAR:	FINISH		ROUNDER AND BREAK SHARP EDGES		DO NOT SCALE DRAWING	REVISION
	NAME	SIGNATURE	DATE		TITLE:	
SEARN						
CHKD						
APPVD						
MG						
SA						
PART 11 - Right Angle Back Extension Tube 2 OD				DWG NO.	SHEET 1 OF 1	
SCALE: 1:1				SHEET 1 OF 1		

HANDLE BACKSTOP Part Layout

Quantity Needed: 2
Raw Materials: 1/16" 6061 Plate
Material Product Number: n/a
Part Number: 2
Page: 1 of 1

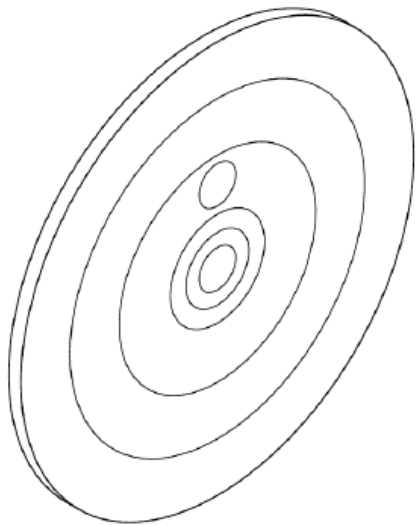

3/16 Counter Rotation Stop/Guide
(TYP 2 PLACES)
Part #3 must be welded on

**Part #1 Must be welded
onto opposite side**

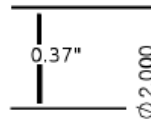

ϕ 2.000

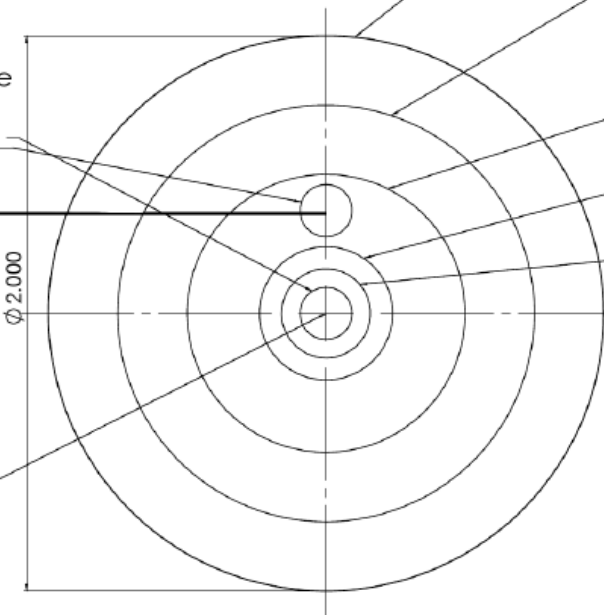

Outside of 2 in OD tube
Part #4 must be welded on

Inside of 2 in OD tube (.25" wall)
AND
Outside of 1.5 in OD tube (1.5")

Inside of 1.5 in OD tube (.25" wall)
(1")

Diameter of Largest Spring .48"

Diameter of Smallest Spring .32"

NO.	REV.	DATE	DESCRIPTION
1			
2			
3			
4			
5			
6			
7			
8			
9			
10			
11			
12			
13			
14			
15			
16			
17			
18			
19			
20			
21			
22			
23			
24			
25			
26			
27			
28			
29			
30			
31			
32			
33			
34			
35			
36			
37			
38			
39			
40			
41			
42			
43			
44			
45			
46			
47			
48			
49			
50			
51			
52			
53			
54			
55			
56			
57			
58			
59			
60			
61			
62			
63			
64			
65			
66			
67			
68			
69			
70			
71			
72			
73			
74			
75			
76			
77			
78			
79			
80			
81			
82			
83			
84			
85			
86			
87			
88			
89			
90			
91			
92			
93			
94			
95			
96			
97			
98			
99			
100			

Must be welded to Part #2

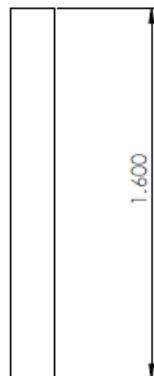
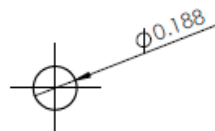

Quantity Needed: 4
 Raw Materials: 3/16" Solid 6061 Rod
 Material Product Number: 8974K29
 Part Number: 3
 Page: 1 of 1

UNLESS OTHERWISE SPECIFIED: DIMENSIONS ARE IN MILLIMETERS SURFACE FINISH: TOLERANCES: LINEAR: ANGULAR:				FINISH:		DEBUR AND BREAK SHARP EDGES		DO NOT SCALE DRAWING		REVISION	
DESIGN	NAME	SIGNATURE	DATE					TITLE:			
CHKD											
APPROV											
MFG											
Part 3 - Spring Guide and CounterRotation							3A31				

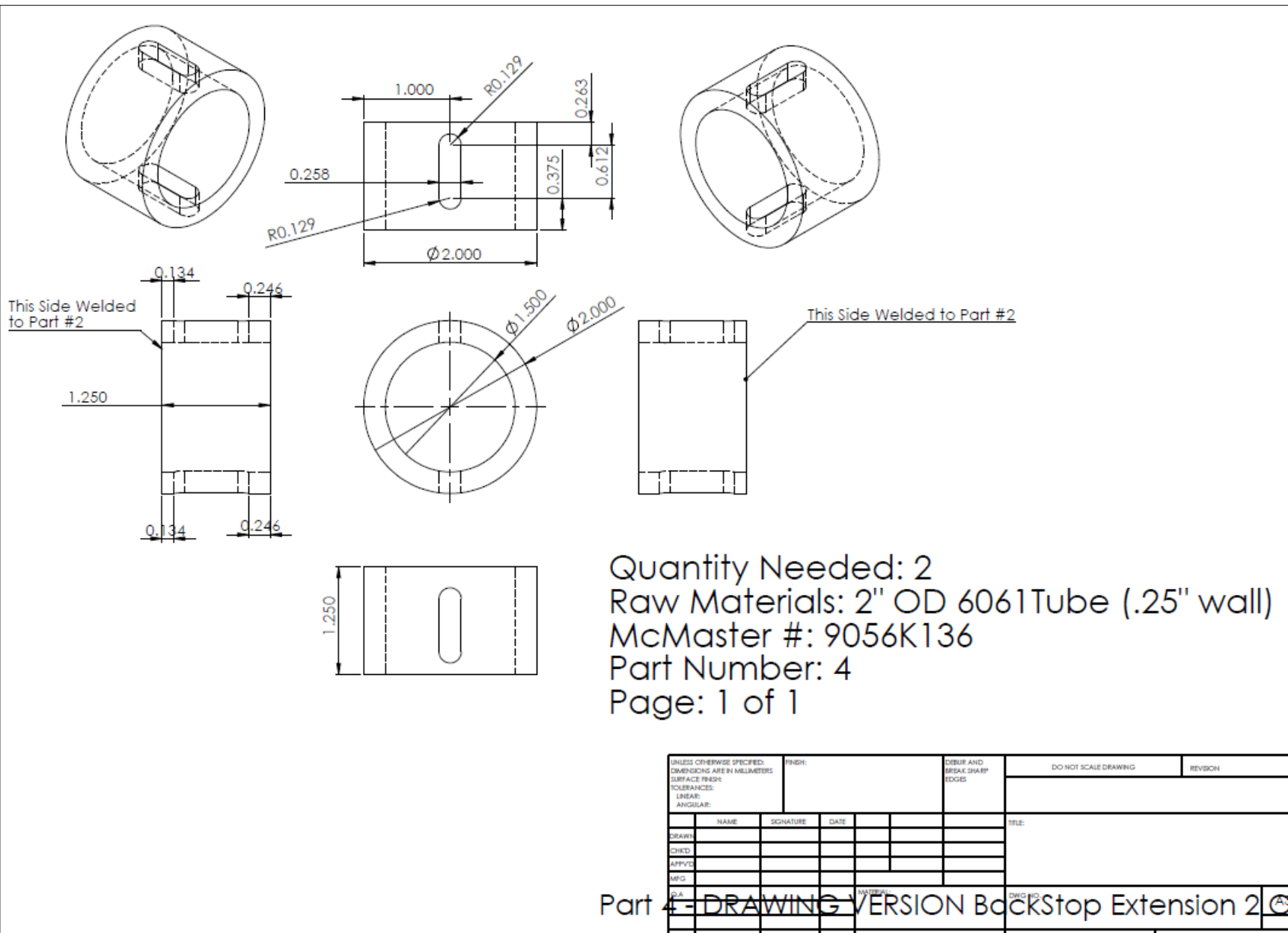

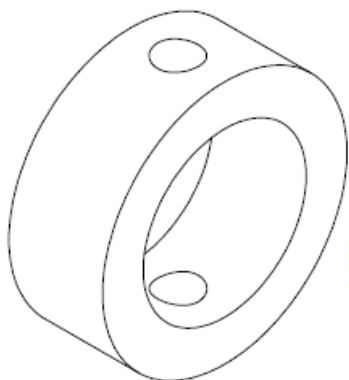

Drill and Tap for 1/4"-20 Screw
McMaster #: 91251A537

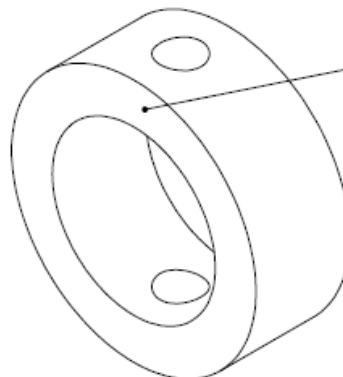
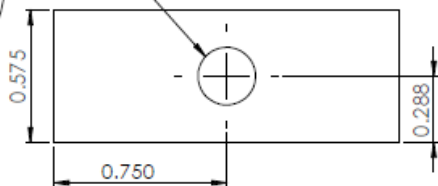

Must be welded to Part #6

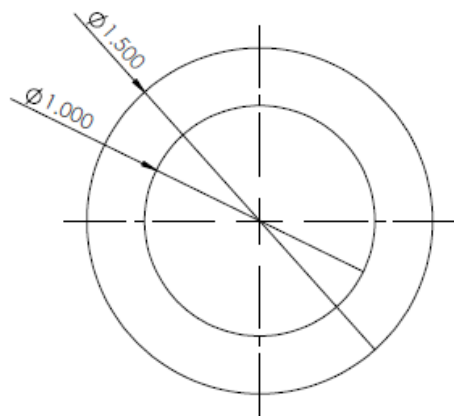

Quantity Needed: 2
Raw Materials: 1.5" OD 6061
McMaster #: 9056K136
Part Number: 5
Page: 1 of 1

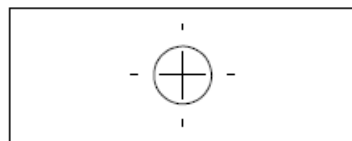

UNLESS OTHERWISE SPECIFIED: DIMENSIONS ARE IN MILLIMETERS		FINISH:		CHAMFER AND BREAK SHARP EDGES		DO NOT SCALE DRAWING		REVISION	
SURFACE FINISH:									
TOLERANCES:									
LINEAR:									
ANGULAR:									
DRAWN	NAME	SIGNATURE	DATE			TITLE			
CHECKED									
APPROVED									
MFG									
QA									
Part 5 - DRAWING VERSION Spring FrontStop 1_1_24									

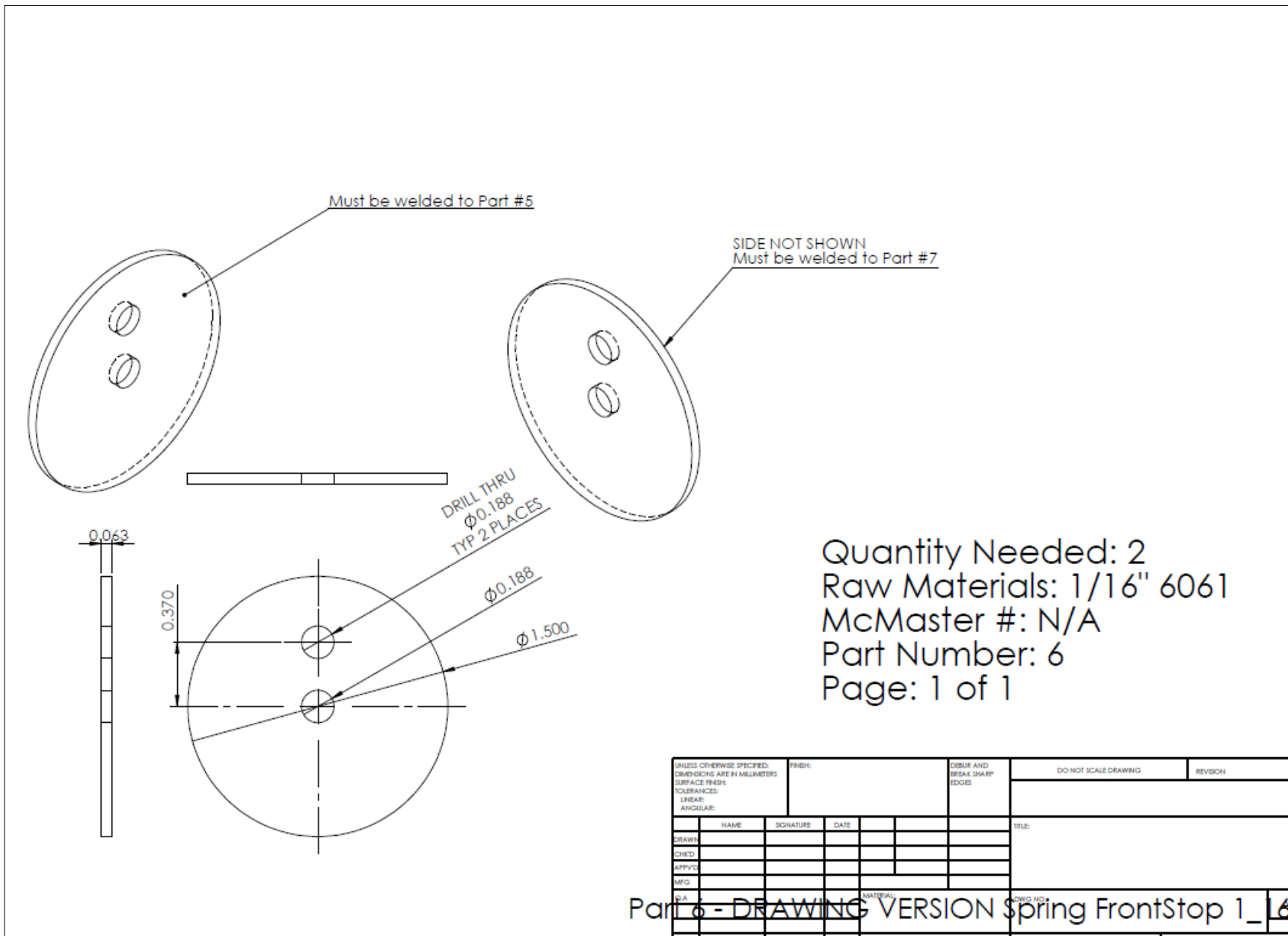

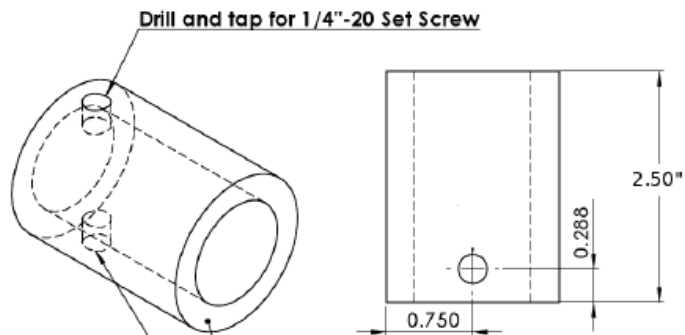

Quantity Needed: 2
 Raw Materials: 1.5" OD 6061
 McMaster #: 9056K136
 Part Number: 7
 Page: 1 of 1

DRILL THRU FOR
 1/4"-20 SCREW

Must be welded to Part #6

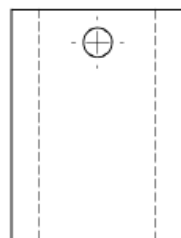
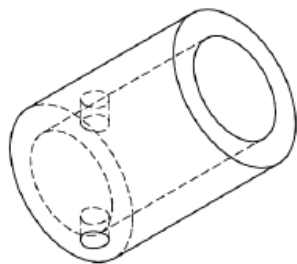
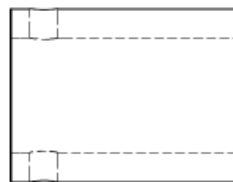
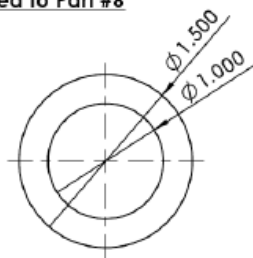
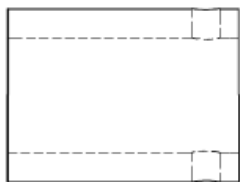

UNLESS OTHERWISE SPECIFIED		DIMEN		DIEUP AND BREAK SHARP EDGES		DO NOT SCALE DRAWING		REVISION	
DIMENSIONS ARE IN MILLIMETERS									
SURFACE FINISH:									
TOLERANCES:									
LINEAR:									
ANGULAR:									
NAME	SIGNATURE	DATE				TITLE			
DRAWN									
CHECKED									
APPROVED									
DATE									
MATERIAL		PART NO.		DRAWING NO.		PART 7 - DRAWING VERSION Pot Holder 1_1_2 OD			

0.500
1.120
1.660
 $\phi 1.000$
 $\phi 0.250$

Quantity Needed: 2
 Raw Materials: 1" Solid 6061 Rod
 Material Product Number: 8974K37
 Part Number: 8
 Page: 1 of 1

Drill and Tap for 1/4"-20 Set Screw

DRILL TO .5" FOR CLEARANCE FOR 1/4"-20 SCREW

Drill Thru 1/4"

DRILL TO .5" FOR CLEARANCE FOR 1/4"-20 SCREW

Drill and Tap for 1/4"-20 Set Screw

DIMENSIONS OTHER THAN SPECIFIED DIMENSIONS ARE IN INCHES SURFACE FINISH: TOLERANCES: LINEAR: ANGULAR:	FINISH	DRAIN AND BREAK SHARP EDGES	DO NOT SCALE DRAWING	REVISION
DRAWN	NAME	SIGNATURE	DATE	TITLE
CHECKED				
APPROVED				
MFG.				
D.A.				
MATERIAL				

Part 8
DRAWING VERSION Solid Connector 1_1_2 So

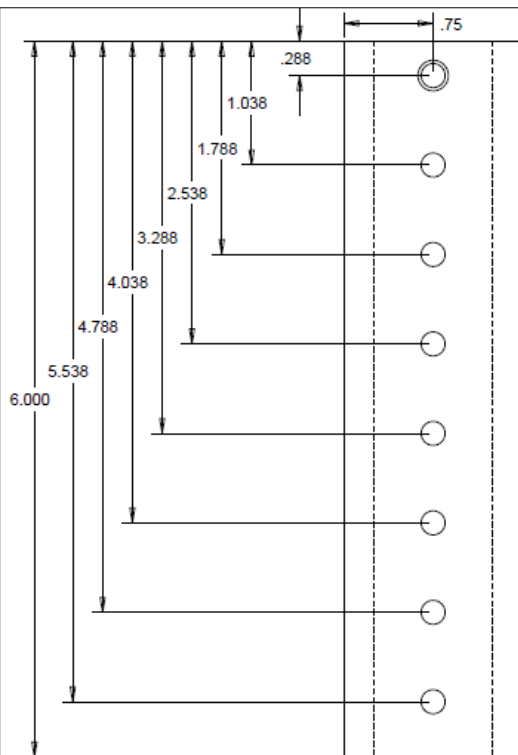

SCALE 1.500

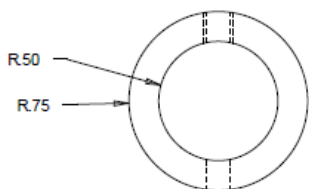

SCALE 1.500

ALL HOLES BUT ONE ARE TAPPED

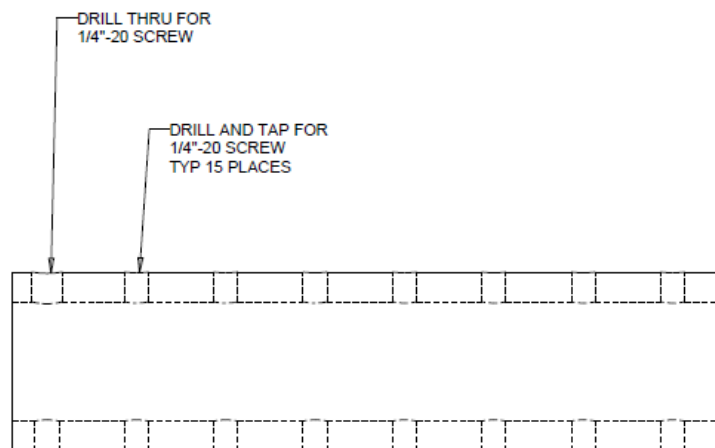

SCALE 1.500

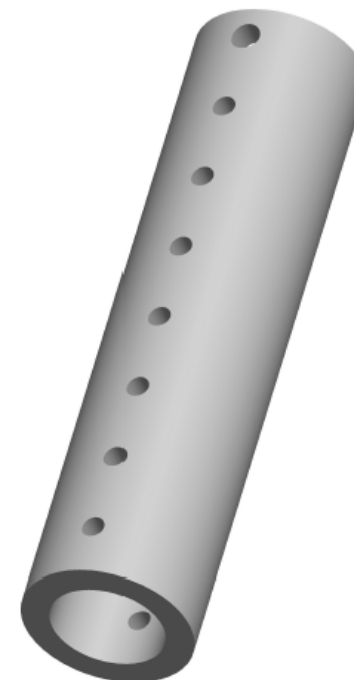

SCALE 1.500

Material: 1.5" OD AL Tube (.25 Thick)
 Quantity: 2
 DIM in INCHES unless noted

ADDITIONAL PARTS REQUIRED FOR ASSEMBLY:	Senior Design - Team # 17 Outdoor Robotic Walker
	PART: handles_9_extension_tube
	Additional Info:
	DATE: JANUARY 31st, 2012
http://eng.fsu.edu/me/senior_design/2012/team17/	

- 1.) Frame Plate
QUANTITY: 16
- 2.) Connector Plate
QUANTITY: 4
- 3.) Connector Plate Pivot Rod
QUANTITY: 4

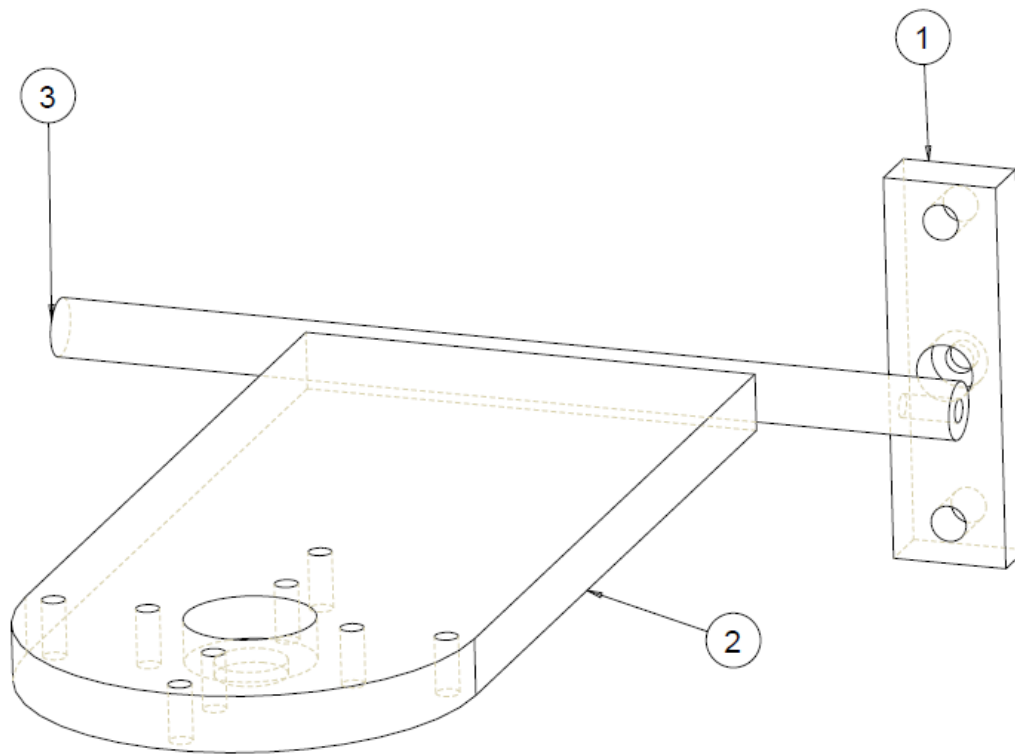

ADDITIONAL PARTS REQUIRED FOR ASSEMBLY:	Senior Design - Team # 17 Outdoor Robotic Walker
	PART: PACKET 4 Connector Plate Assembly
	Additional Info: 3 Total Parts
	DATE:
http://eng.fsu.edu/me/senior_design/2012/team17/	

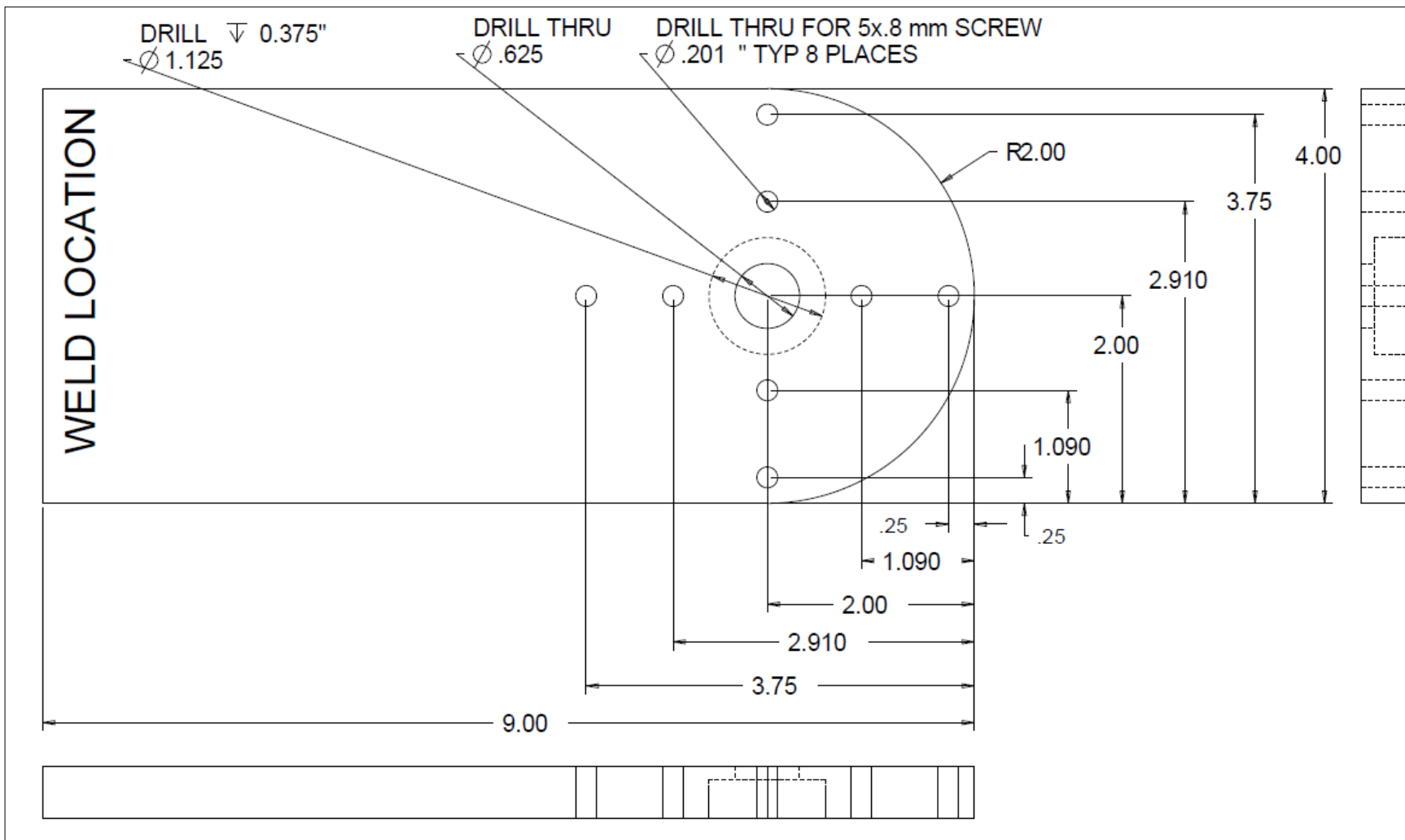

Assembly: 4
 Part: 2 of 3
 Material: 1/2" ALUMINUM PLATE
 Quantity: 4
 DIM in INCHES unless noted

ADDITIONAL PARTS REQUIRED FOR ASSEMBLY:	Senior Design - Team # 17 Outdoor Robotic Walker
	PART: steering_motor_bottom_plate
	Additional Info:
	DATE: JANUARY 31st, 2012
http://eng.fsu.edu/me/senior_design/2012/team17/	

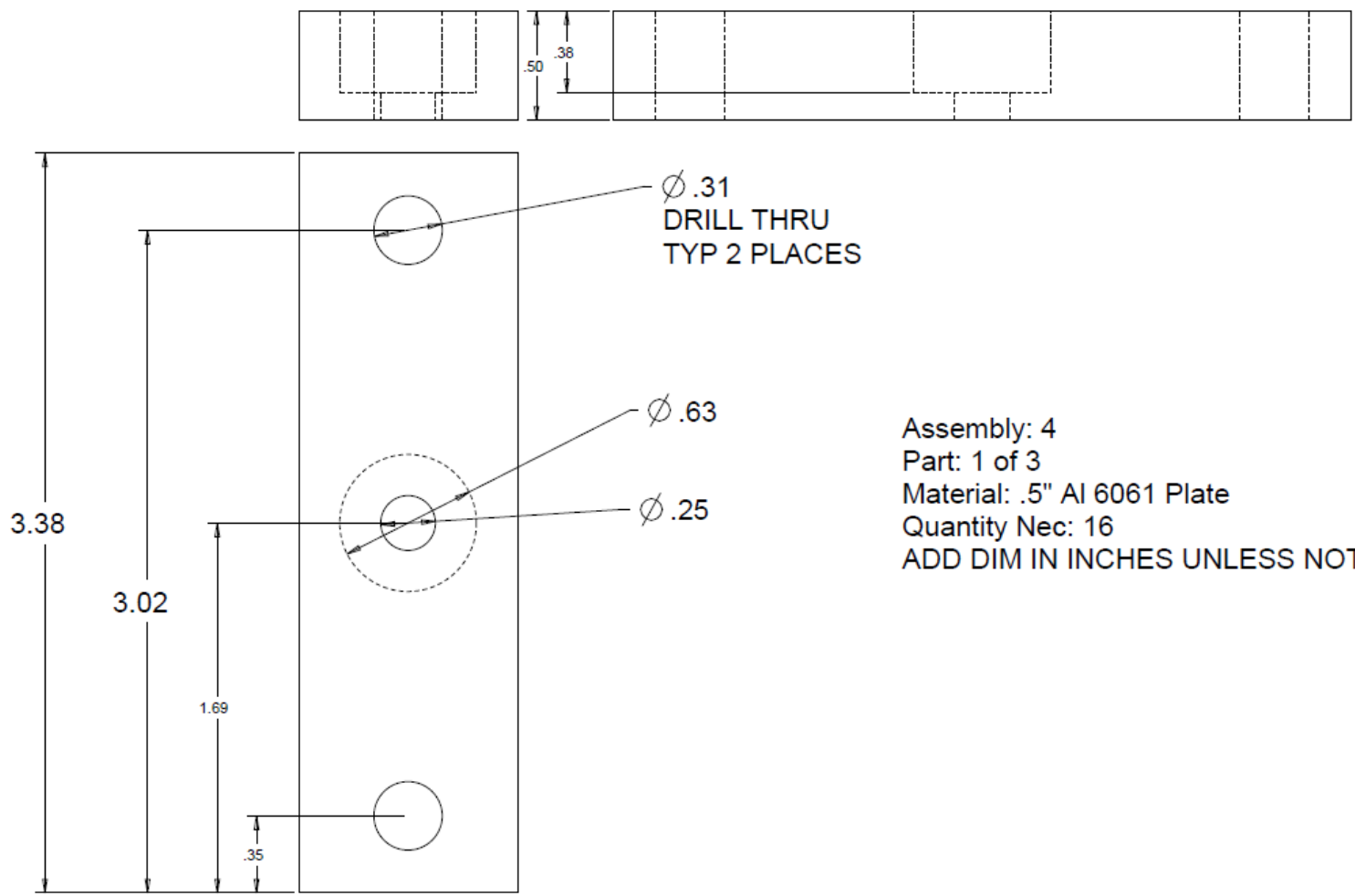

Assembly: 4
 Part: 1 of 3
 Material: .5" Al 6061 Plate
 Quantity Nec: 16
 ADD DIM IN INCHES UNLESS NOTED

DXF FILE NAME: packet4_part1of3connectorplate

ADDITIONAL PARTS REQUIRED FOR ASSEMBLY:	Senior Design - Team # 17 Outdoor Robotic Walker
	PART: PACKET 4 Connector Plate Assembly Frame Plate (QTY: 16)
	Additional Info: part 1 of 3
	DATE:
http://eng.fsu.edu/me/senior_design/2012/team17/	

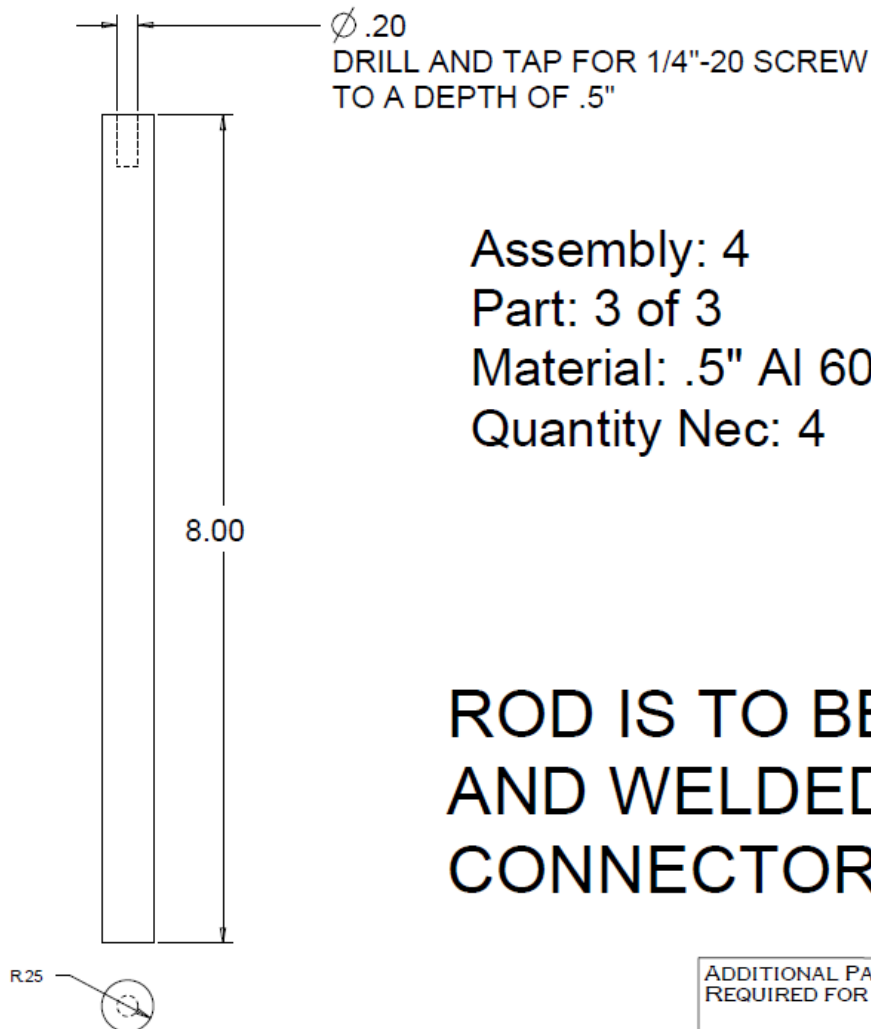

Assembly: 4
 Part: 3 of 3
 Material: .5" Al 6061 Rod
 Quantity Nec: 4

**ROD IS TO BE CENTERED
 AND WELDED TO
 CONNECTOR PLATE**

ADDITIONAL PARTS REQUIRED FOR ASSEMBLY:	Senior Design - Team # 17 Outdoor Robotic Walker
	PART: PACKET 4 Connector Plate Assembly Connector Plate Pivot Rod
	Additional Info: part 3 of 3
	DATE:
http://eng.fsu.edu/me/senior_design/2012/team17/	

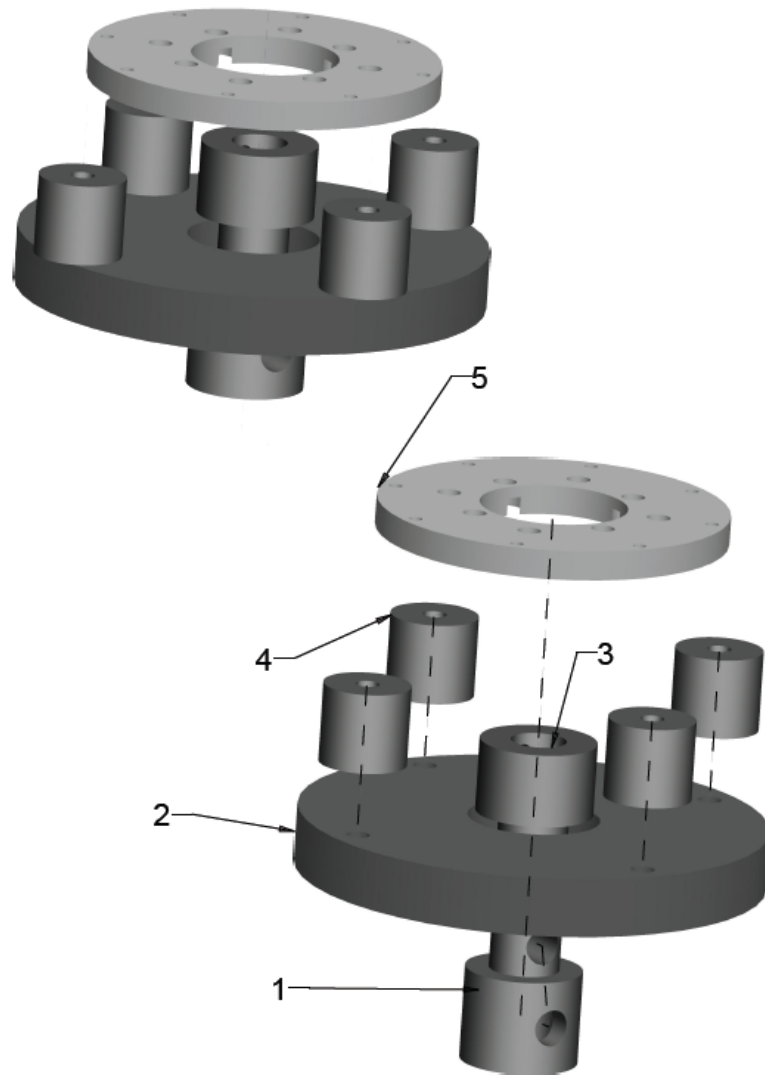

1. Steering Motor Transfer Cup
Quantity: 2

2. Steering Motor Secondary
Bearing Plate
Quantity: 2

3. Screw Protector
Quantity: 8

4. Steering Motor Rotation Connect
Quantity: 2

5. Steering Motor Bottom Cap
Quantity: 2

Material: 2.5" OD AL Tube (.25 Thick)
Quantity: 2
DIM in INCHES unless noted

ADDITIONAL PARTS REQUIRED FOR ASSEMBLY:	Senior Design - Team # 17 Outdoor Robotic Walker
	PART: <code>caster_leg</code>
	Additional Info:
	DATE: JANUARY 31st, 2012
http://eng.fsu.edu/me/senior_design/2012/team17/	

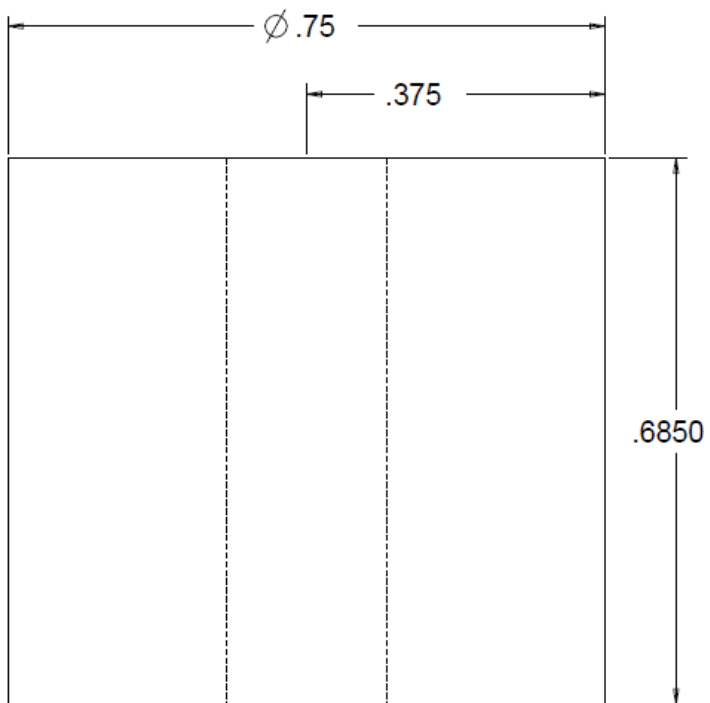

Material: 0.75" Aluminum Rod
 Quantity: 8
 DIM in INCHES unless noted

PACKET: 5
 PART: 3 of 5
 NAME: Screw Protector

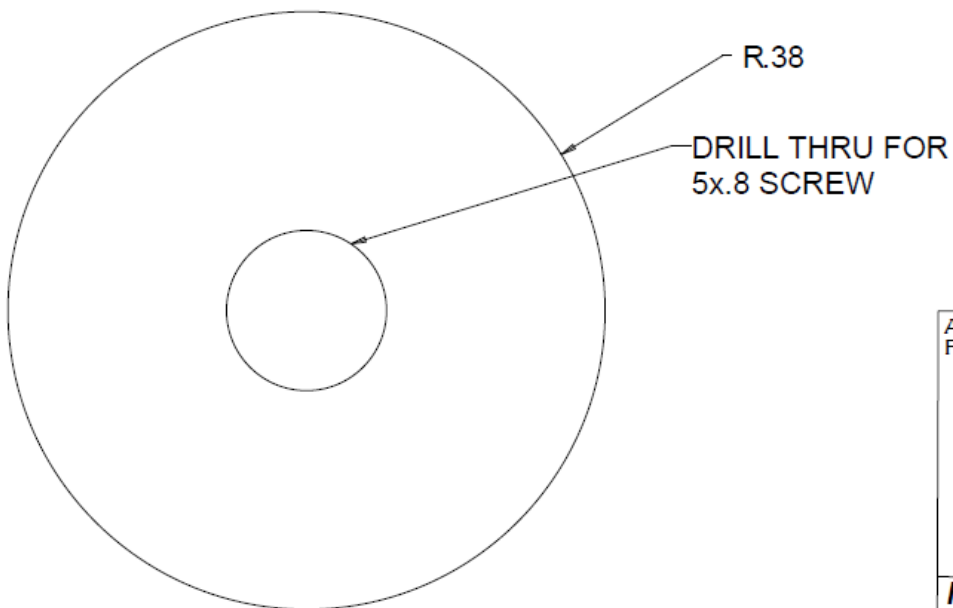

ADDITIONAL PARTS REQUIRED FOR ASSEMBLY:	Senior Design - Team # 17 Outdoor Robotic Walker
	PART: screw_protector
	Additional Info:
	DATE: JANUARY 31st, 2012
http://eng.fsu.edu/me/senior_design/2012/team17/	

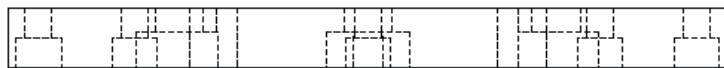
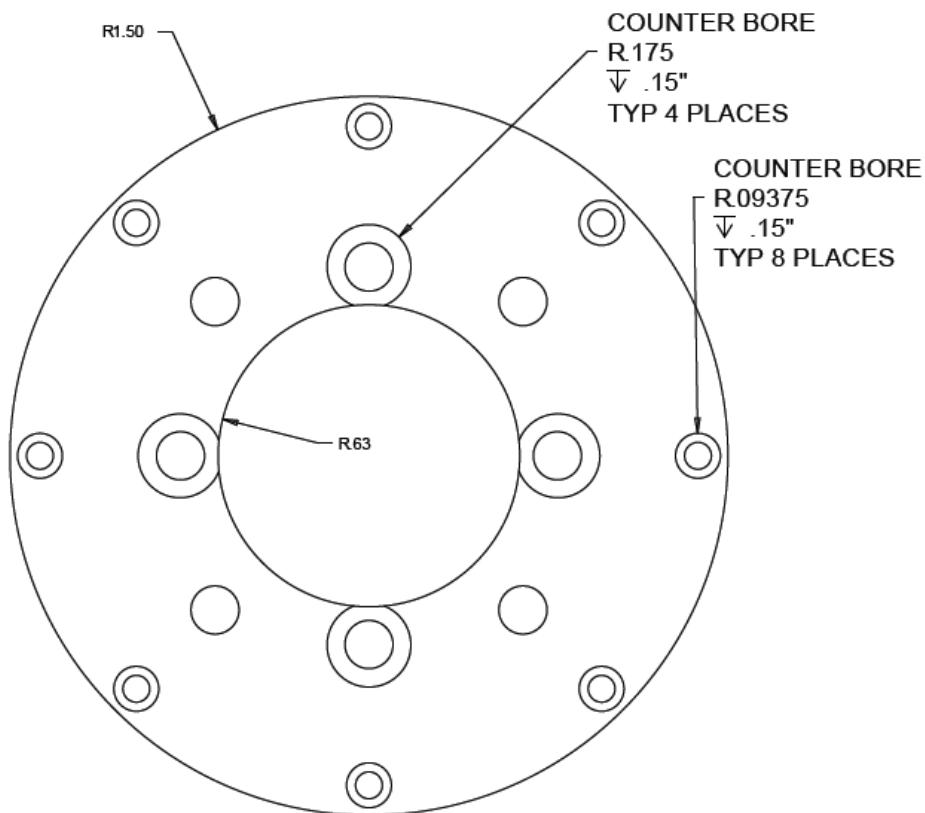

SCALE 3.000



SCALE 3.000

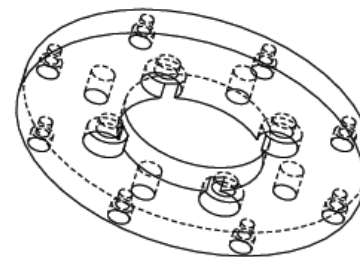

SCALE 1.500

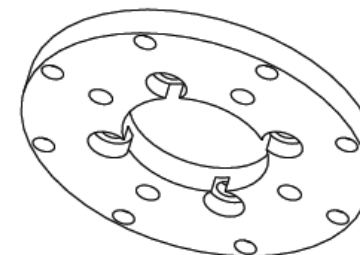

SCALE 1.500

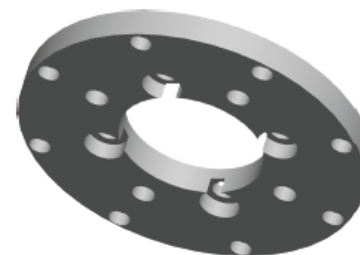

SCALE 1.500

Material: .25" POLYCARBONATE
Quantity: 2
DIM in INCHES unless noted

PACKET: 5
PART: 5 of 5
NAME: Steering Motor Bottom Cap

ADDITIONAL PARTS REQUIRED FOR ASSEMBLY:	Senior Design - Team # 17 Outdoor Robotic Walker
	PART: steering_motor_bottom_cap
	Additional Info:
	DATE: JANUARY 31st, 2012
http://eng.fsu.edu/me/senior_design/2012/team17/	

Material: 1" OD SS Rod
 Quantity: 2
 DIM in INCHES unless noted

PACKET: 5
 PART: 4 of 5
 Name: Steering Motor Rotation Connect

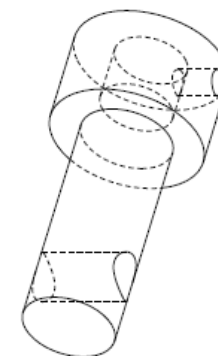

SCALE 2.000

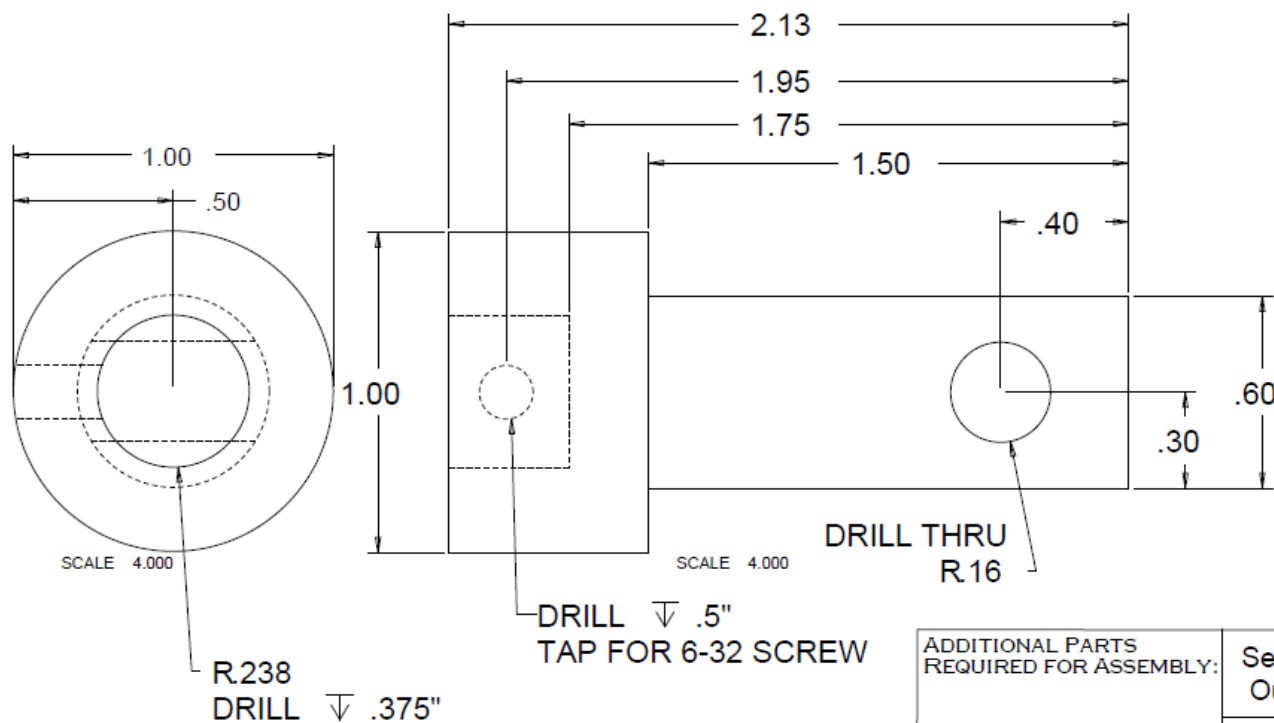

ADDITIONAL PARTS REQUIRED FOR ASSEMBLY:	Senior Design - Team # 17 Outdoor Robotic Walker
	PART: steering_motor_rotation_connect
	Additional Info:
	DATE: JANUARY 31st, 2012

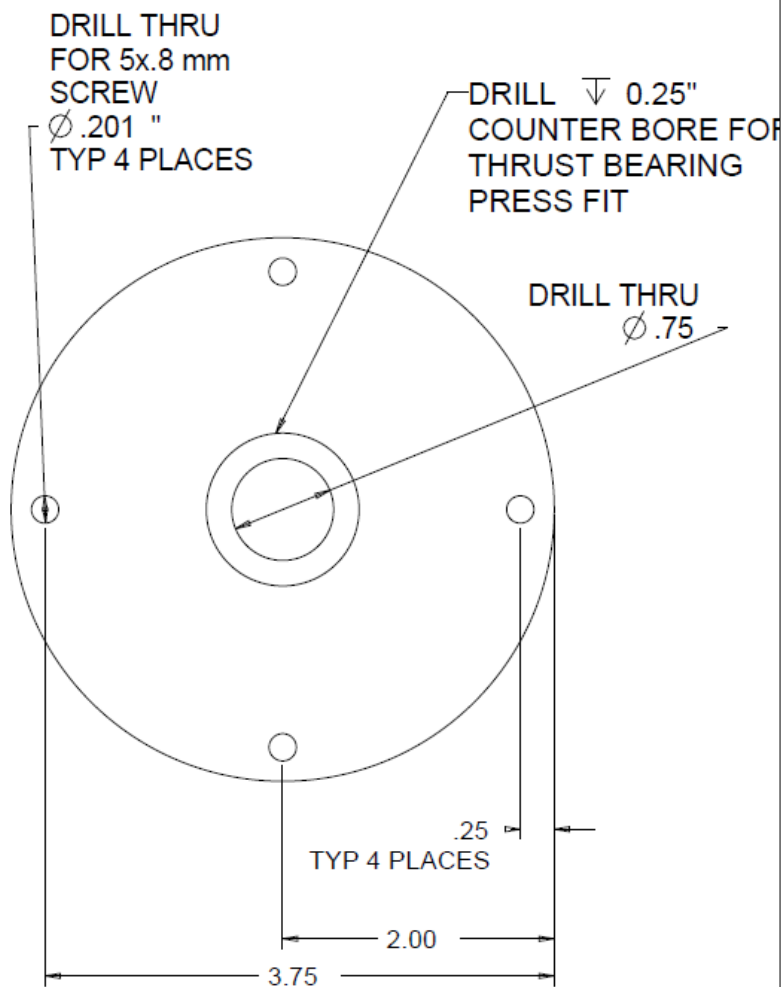
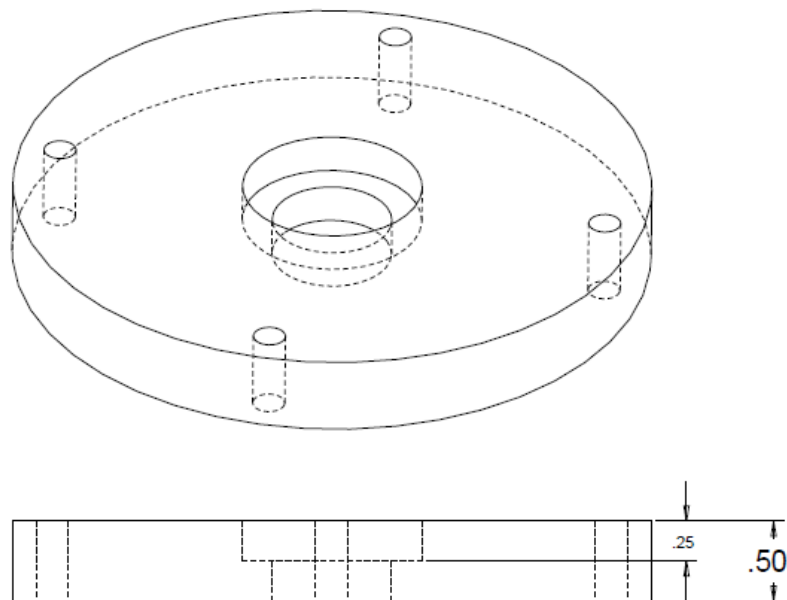

Material: 0.5" Aluminum Plate
 Quantity: 2
 DIM in INCHES unless noted

PACKET: 5
 PART: 2 of 5
 NAME: Steering Motor Secondary
 Bearing Plate

ADDITIONAL PARTS REQUIRED FOR ASSEMBLY:	Senior Design - Team # 17 Outdoor Robotic Walker
	PART: STEERING_MOTOR_SEC_BEARING_PL
	Additional Info:
	DATE: JANUARY 31st, 2012
http://eng.fsu.edu/me/senior_design/2012/team17	

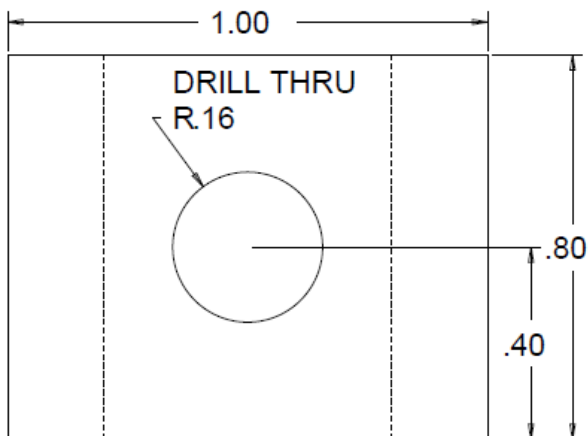
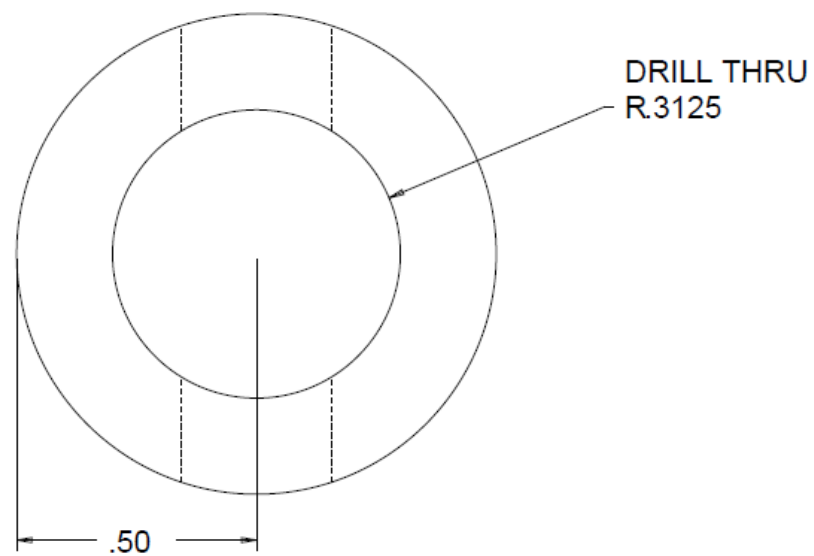

SCALE 6.000

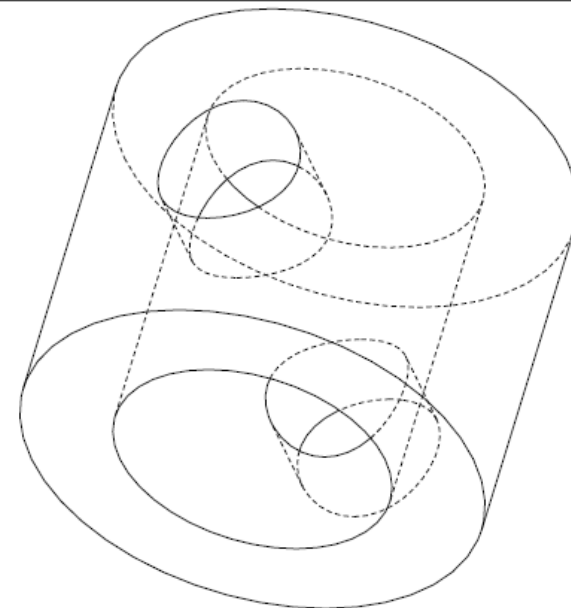

SCALE 6.000

Material: 1" OD AL Rod
 Quantity: 2
 DIM in INCHES unless noted

PACKET: 5
 PART: 1 of 5
 NAME: Steering Motor Transfer Cup

ADDITIONAL PARTS REQUIRED FOR ASSEMBLY:	Senior Design - Team # 17 Outdoor Robotic Walker
	PART: steering_motor_transfer_cup
	Additional Info:
	DATE: JANUARY 31st, 2012
http://eng.fsu.edu/me/senior_design/2012/team17/	

Assembly: 6
Part: 1 of 4
Quantity Necessary: 1
Material: Al 6061 1.5" OD Rod

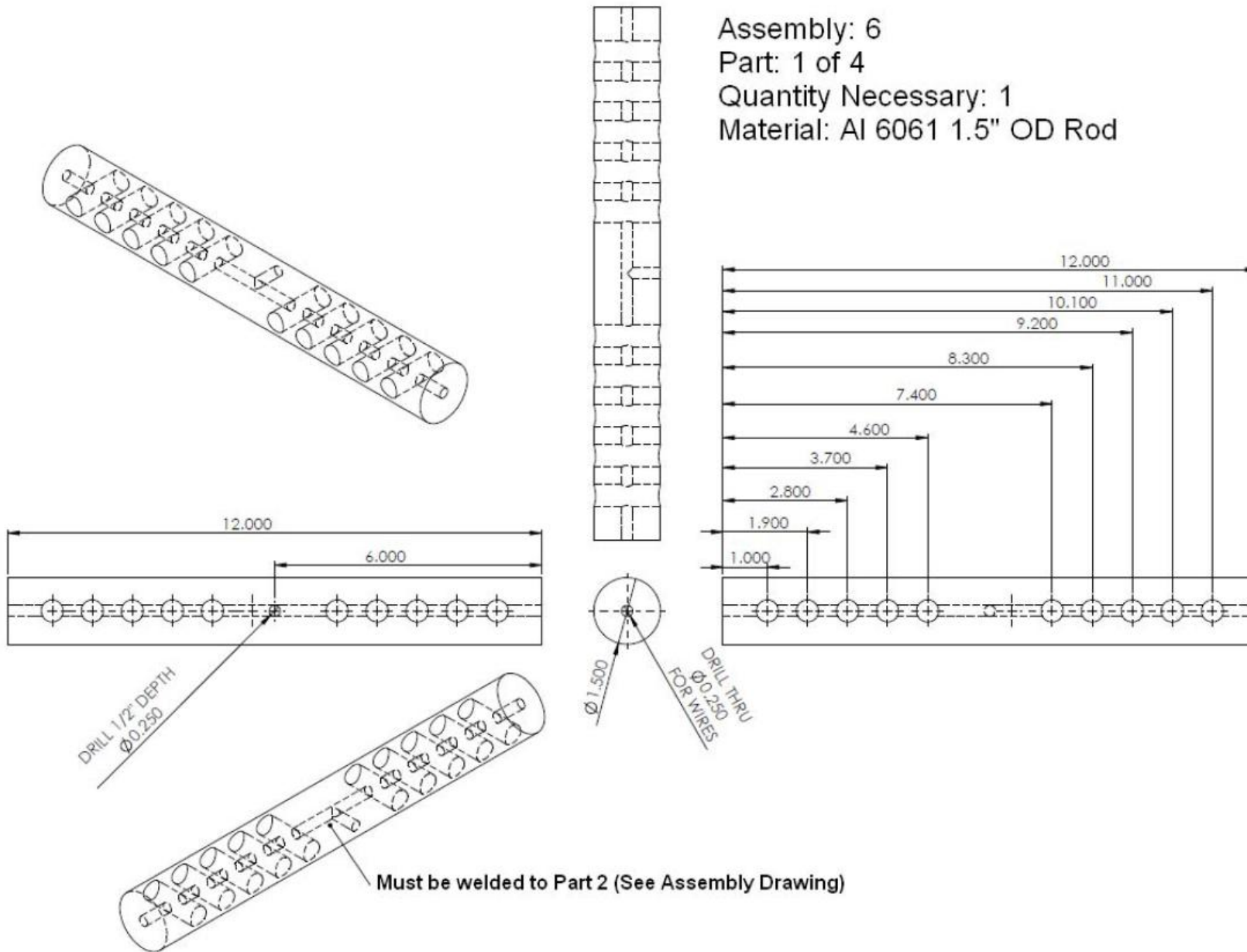

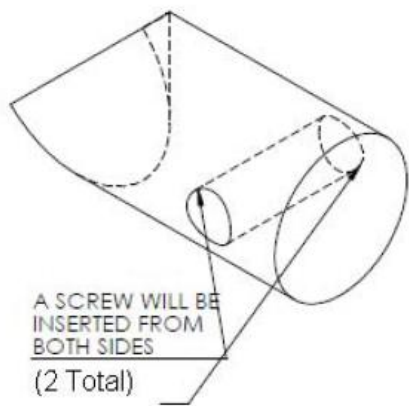

A SCREW WILL BE
INSERTED FROM
BOTH SIDES
(2 Total)



Assembly: 6
Part: 2 of 4
Quantity Necessary: 1
Material: 1.5" OD Al 6061 Rod

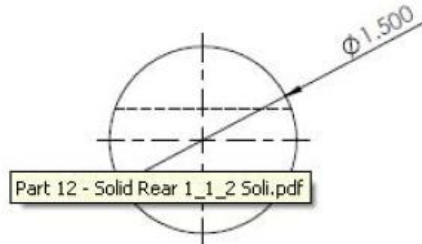
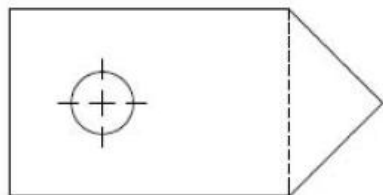

**Must be welded to
Part 1**

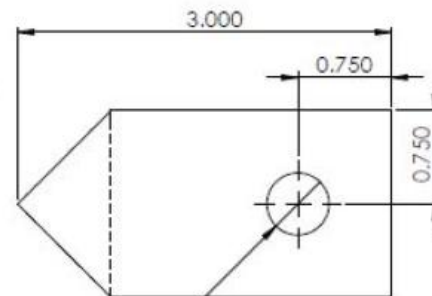

DRILL AND TAP FOR
 $\phi 0.500-20$
TYP 2 PLACES

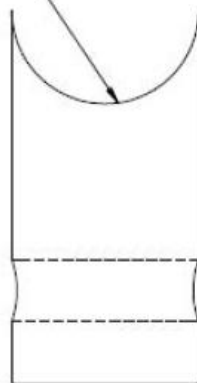
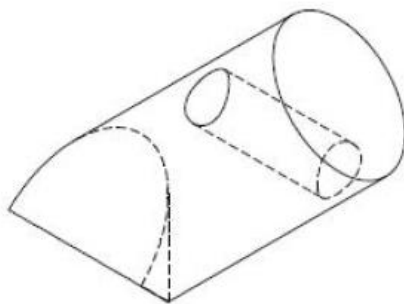

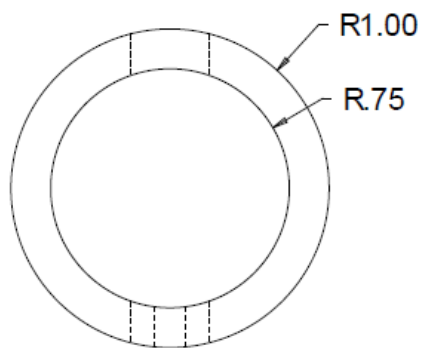

Assembly: 6
 Part: 3 of 4
 Material: 2.5" OD AL Tube (.25 Thick)
 Quantity: 1
 DIM in INCHES unless noted

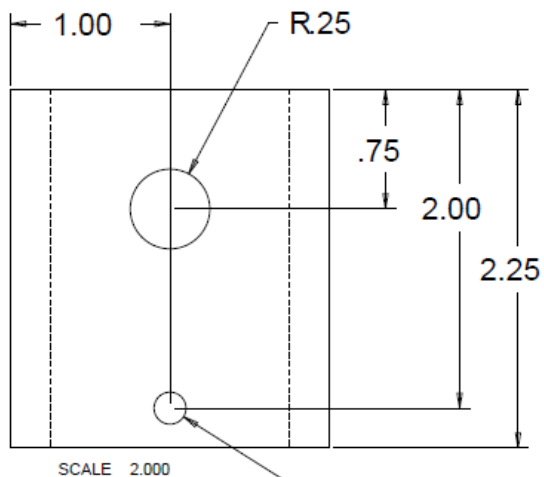

Drill and Tap
 for 1/4"-20 Clearance

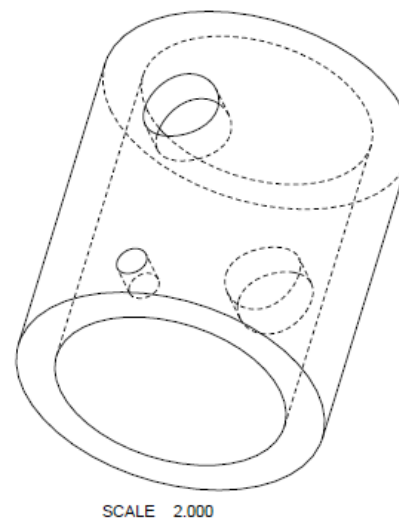

ADDITIONAL PARTS REQUIRED FOR ASSEMBLY:	Senior Design - Team # 17 Outdoor Robotic Walker
	PART: rear_base
	Additional Info:
	DATE:
http://eng.fsu.edu/me/senior_design/2012/team17/	

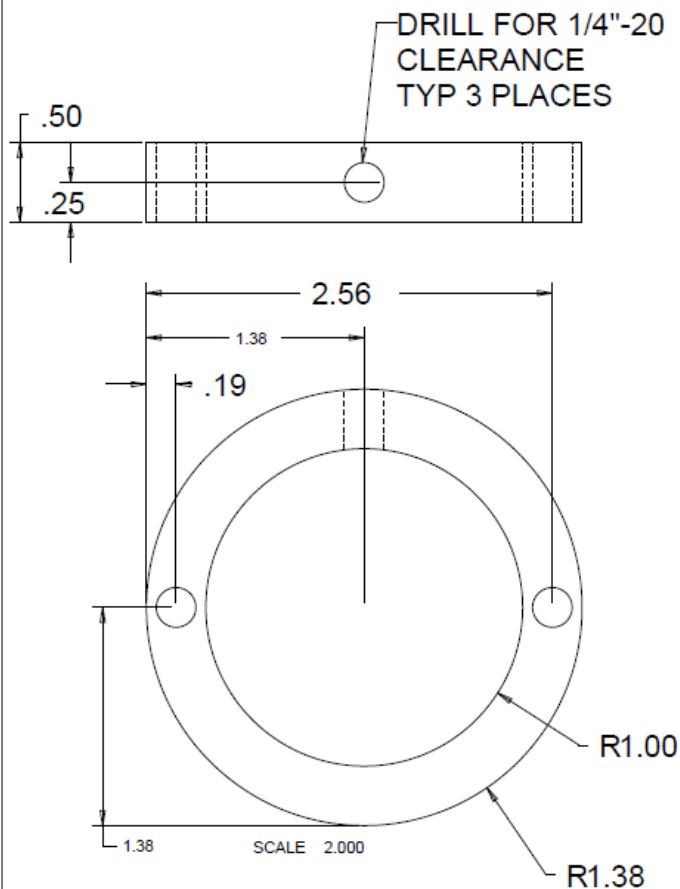

Assembly: 6
 Part: 4 of 4
 Material: .5" AL Plate
 Quantity: 1
 DIM in INCHES unless noted

DXF PROVIDED

ADDITIONAL PARTS REQUIRED FOR ASSEMBLY:	Senior Design - Team # 17 Outdoor Robotic Walker
	PART:
	Additional Info:
	DATE:
http://eng.fsu.edu/me/senior_design/2012/team17/	

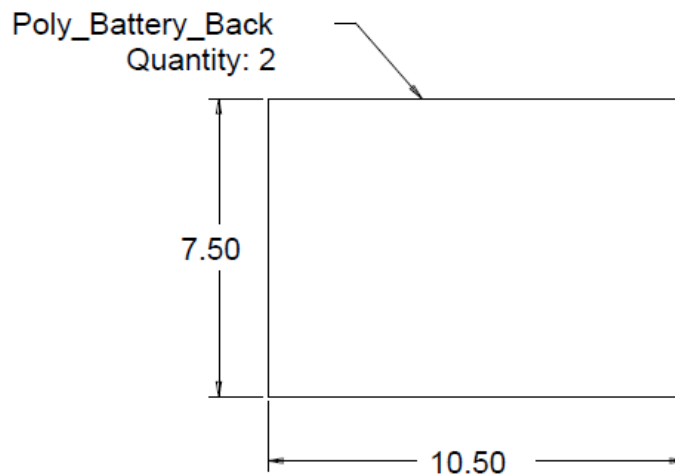
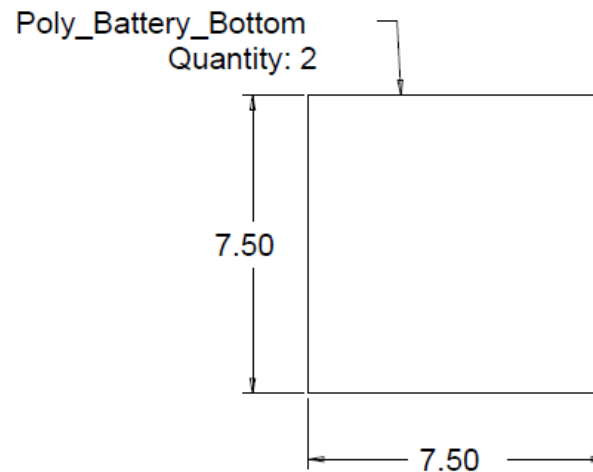
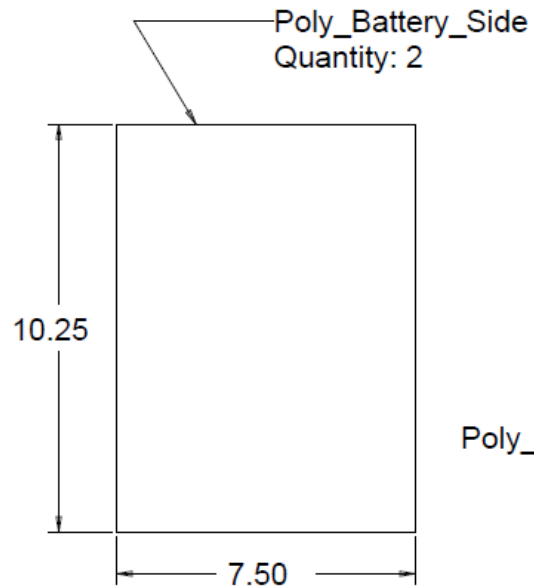

Assembly: 7

Material: Polycarbonate Sheet

Quantity: 2 of Each (6 Total)

DIM in INCHES unless noted

NO DXF SUPPLIED

ADDITIONAL PARTS REQUIRED FOR ASSEMBLY:	Senior Design - Team # 17 Outdoor Robotic Walker
	PART:
	Additional Info:
	DATE: JANUARY 31st, 2012
http://eng.fsu.edu/me/senior_design/2012/team17/	

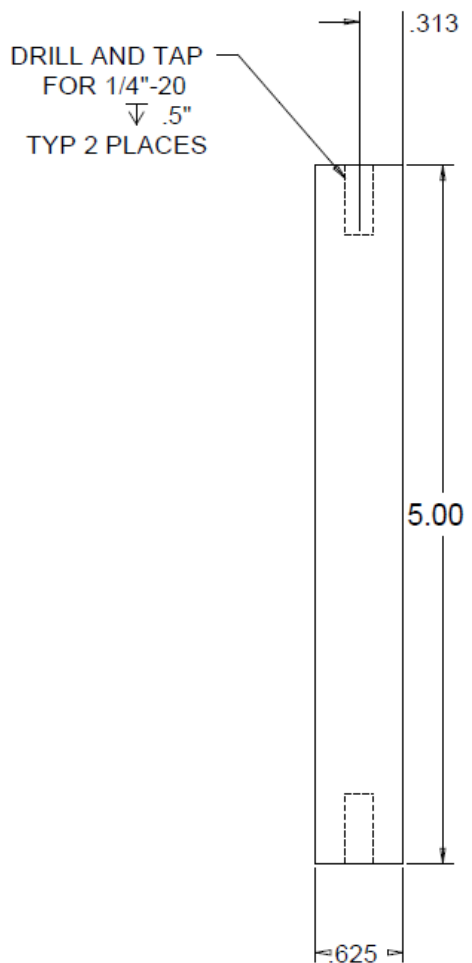

MUST BE LATHED TO FIT IN PILLOW BLOCK

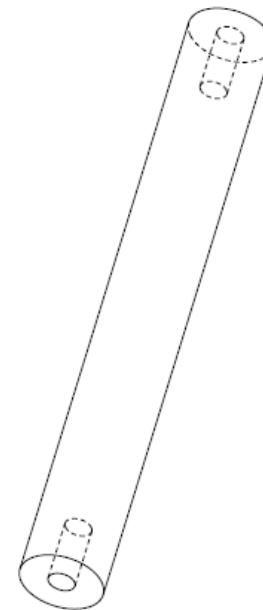

Assembly: 8
 Part: 1 of 2
 Material: 5/8" Aluminum Rod
 Quantity: 4
 DIM in INCHES unless noted

ADDITIONAL PARTS REQUIRED FOR ASSEMBLY:	Senior Design - Team # 17 Outdoor Robotic Walker
	PART: shock_swing_arm
	Additional Info:
	DATE:
http://eng.fsu.edu/me/senior_design/2012/team17/	

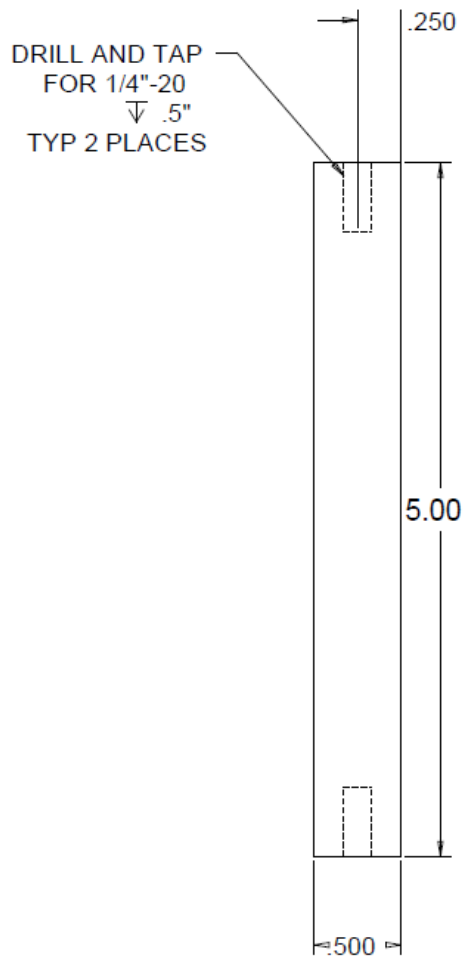

MUST BE LATHED TO FIT IN PILLOW BLOCK

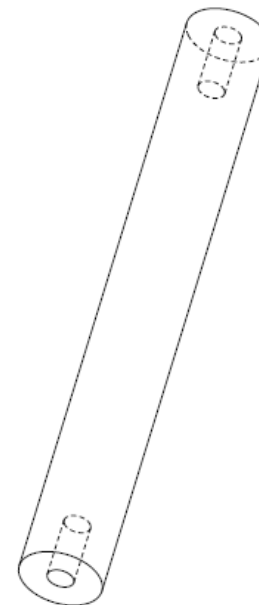

Assembly: 8
 Part: 2 of 2
 Material: 1/2" Aluminum Rod
 Quantity: 4
 DIM in INCHES unless noted

ADDITIONAL PARTS REQUIRED FOR ASSEMBLY:	Senior Design - Team # 17 Outdoor Robotic Walker
	PART: shock_swing_arm
	Additional Info:
	DATE:
http://eng.fsu.edu/me/senior_design/2012/team17/	

(11.0) References

- http://www.infouse.com/disabilitydata/disability/2_2.php.
- http://en.wikipedia.org/wiki/File:Caution_sign_used_on_roads_pn.svg
- <http://www.flickr.com/photos/chrisgold/6435078007/lightbox/>
- <http://www.case.edu/think/breakingnews/careproject.html>
- <http://www.nashuatelegraph.com/sportslocalsports/954816-222/art-demers-focusing-on-return-to-classroom.html#>
- <http://thesnowangels.org/>
- <http://hic2011.edublogs.org/2011/10/20/green/>
- <http://topnews.net.nz/content/211444-7000-red-cross-volunteers-put-100-worth-free-labour-each>
- <http://www.access-board.gov/adaag/html/>
- <http://www.a-m-c.com/images/productpics/120a10.jpg>
- http://www.easycomforts.com/EasyComforts/subcategory.aspx?id=mobility%20and%20accessories&bid=EC_Flash2^Mobility%20and%20Accessories
- <http://www.4-medical-supplies.com/electric-power-wheelchairs/>
- <http://www.assistivedeviceskey.com/category/2185098>
- <http://www.rimdoor.com/page.cfm?page=140>
- http://hungyulin.com/?page_id=5
- <http://www.hizook.com/blog/2009/08/10/robotic-walkers-assist-elderly>
- http://news.cnet.com/8301-13639_3-10098240-42.html
- http://www.robotcombat.com/store_tanktreads.html
- <http://www.directindustry.com/prod/kistler/force-plates-5346-40016.html>
- <http://dcacmotors.blogspot.com/2009/08/dc-motors-torquespeed-curves.html>
- http://en.wikipedia.org/wiki/File:Mass_spring_damper.png
- <http://www.superstock.com/resultsframe.asp>

(12.0) Member Biography

Michael Bunne

Michael is a senior at Florida State University and will graduate this April with a B.A. in Music and a B.S. in Mechanical Engineering. He has played the trombone for almost 13 years and considers music an essential part of his life. His love for music is only equaled by his passion for robotics. Michael is currently completing an Honors Thesis focusing on the lateral dynamics of a biologically-inspired running robot and intends to continue working on mobile robotics for many years to come. He has been accepted into the Mechanical Engineering Master's Program at Stanford University and hopes his graduate studies will lead him towards a career in the space exploration industry.

John Jagusztyn

After his 5th year of schooling at Florida State University, John will be graduating in late April 2012 with a Bachelor's of Science degree in Mechanical Engineering. For extracurricular activity, John is actively involved as the President of Florida State's Men's Club Soccer team as well as refereeing youth and adult soccer leagues in the local Tallahassee area. Outside of school, John enjoys keeping up current affairs, playing video games and guitar, watching movies, following the stock market and spending time with his friends and family. He has specific interests in the field of thermodynamics and plans to further his learning as he enters the work force. John will be relocating to Houston, TX at the completion of his college career to pursue his interests in the energy industry.

Jonathan Lenoff

Jonathan Lenoff is currently a senior at FSU and expects to graduate after this semester. During his time here at FSU he says he has gained practical knowledge and experience relating to engineering. He is excited for the next step in his life but knows that it will be a bitter sweet experience leaving the school and friends that have helped him so much over the past four years. Jonathan would like to thank everyone who has helped him get to this point including his parents, friends and teachers as well as Group 17 for making an awesome senior design project.