

Critical Current Probe

Senior Design Final Report – April 2012

By

Amy Eckerle, Philip Witherspoon, Andrew Whittington
*Department of Mechanical Engineering
Florida State University*



Project Sponsor

Dr. Ulf Trociewitz



Department of Mechanical Engineering
FAMU-FSU College of Engineering
2525 Pottsdamer St, Tallahassee, FL 32310

Introduction to the critical current probe

The critical current probe is specifically used to test the critical current in BSCCO superconductor short samples. A total of eight straight short samples can be mounted on the probe at one time. The sample holder is design to allow for the samples to be soldered directly to the exposed pads on the sample holder. The placement of these samples and how to select the lead to power during testing is explained below in the How to select different samples section. This particular probe is designed for insertion into cryogenic liquids and exposed to magnetic fields. This allows for testing in cryostats with back ground fields of up to 9T. Instruction on assembling the probe, operations, and safety warning is explained throughout this operations manual.

Operation of assembled probe

The probe can be used in many different ways. This guide will not give explicit instruction on how to run an experiment but rather only give and explanation of how to select certain samples on the sample holder. Instrumentation wiring can be done at the users owen discretion. Reclamation port on the side the stainless tube is designed for standard K.F. flange fitting and can be plugged or used at the discretion of the user.

How to select different samples on the sample holder

To select different samples mounted on the sample holder refer to the chart below. The chart shows a picture of the front and the back of the sample holder with a chart on how to determine which sample is connected to which leads. If you are confused about which face of the sample holder is the top support the probe on a table and rotate the top around until leads 1, 2, and 3 are above 4, 5, and 6. With them parallel to the table the sample holder will be parallel with the table as well. The side of the sample holder that is facing away from the table is the front of the sample holder. Please view the charts below to determine which leads to connect to in order to test your sample.

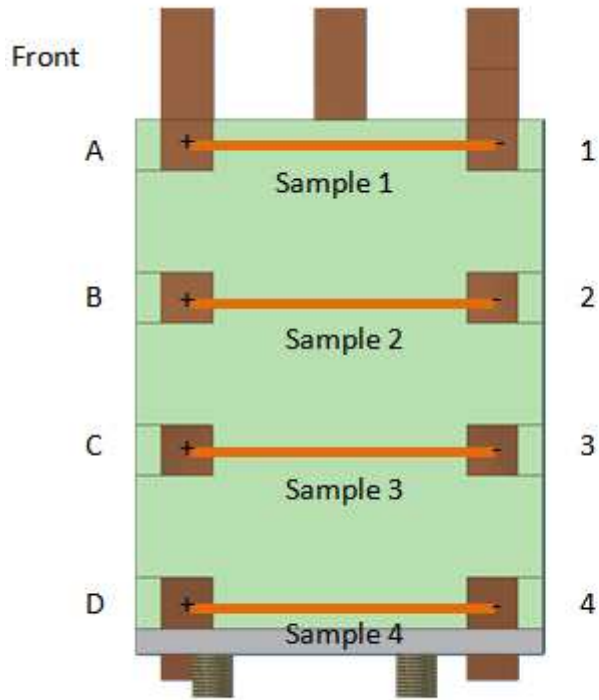

Sample #	Corresponding Label	Lead #s
1	A, 1	4, 3
2	B, 2	4, 2
3	C, 3	1, 3
4	D, 4	1, 2

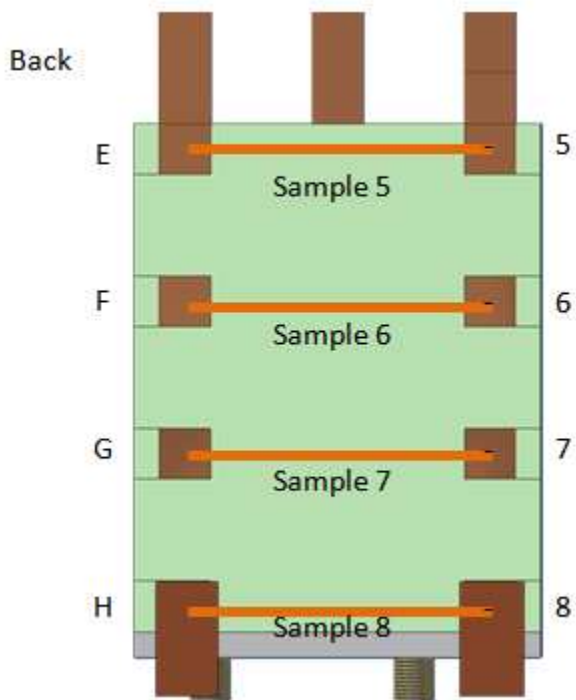

Sample #	Corresponding Label	Lead #s
5	E, 5	4, 6
6	F, 6	4, 5
7	G, 7	1, 6
8	H, 8	1, 5

Packing slip:

Part NO.	Part name	Quantity
1	G-10 Top Flange	1
2	Copper Current leads	6
3	Aluminum angle brackets	6
4	Current connects	6
5	Instrumentation tube	1
6	Stainless steel jacket with connecting flange	1
7	G-10 Jacket	1
8	G-10 spacer	2
9	G-10 Connector	1
10	O-ring	1
11	YBCO current leads	6
12	Sample holder	1
13	G-10 Top Spacer	1
14	G-10 bottom spacer	1
15	G-10 support rods	4
16	G-10 guidance cap	1
17	angle bracket bolts and nuts	12
18	G-10 top flange Bolts and nuts	4
19	G-10 connector set screws	16
20	Stycast	1
21	rubber stopper	1
22	bottom spacer hex screws	4
23	Sample holder threaded stud with nuts	3

Getting started:

Thank you for purchasing the Applied Superconductivity Centers' helium efficient critical current probe for short and spiral sample superconductors. Before starting assembling the probe please read all instructions carefully and thoroughly. Failure to do so can result in irreparable damage to the probe, serious injury, or even death to the user.

Packing list and parts:

When opening the crate the probe came in please identify and read the packing slip. The packing slip will contain the list of all included parts with part numbers and quantities of each respective part. Please remove all packaged parts from the box but do not unpackaged the individual parts. Each package should have a part number, description of the part, and quantity of the part in each package. Please check to make sure all parts are present match the packing slip. If there are any missing or damaged parts do not attempt to use probe. Contact the ASC immediately and the missing or damaged parts will be replaced immediately. Failure to do so can result in damage to testing equipment the probe is used with, serious injury, or even death. If you are not sure that a part is damaged please refer to the part description section of the operations manual for the part in question under "Signs of Damage" or call the ASC.

Step 1:

Needed Part Numbers: 1, 3, 17

Required tools: Two adjustable crescent wrenches

- a.) Remove parts 1, 3, 18 from their respective packages and inspect each part for damage.
- b.) Place part 1, G-10 top flange, flat on the table as shown below. It does not matter which face is flat on the table. Identify angle bracket holes shown on the diagram below. These holes match the pair of holes on part 3, aluminum angle brackets.
- c.) Match holes of part 3 to part 1 as shown in figure 1. Make sure the slotted channel on part 3 is closest to the edge of part 1. Please refer to figure 1 for the proper placement and orientation of part 3 to part 1. Do this for all of the angle brackets, part 3.
- d.) Now that the holes of each of the angle brackets, part No. 3, match part 1 place 2 of part 18 through each hole of each of the six angle brackets as shown in figure 1. Tighten nuts on to the bolts of part 18 with the two crescent wrenches.

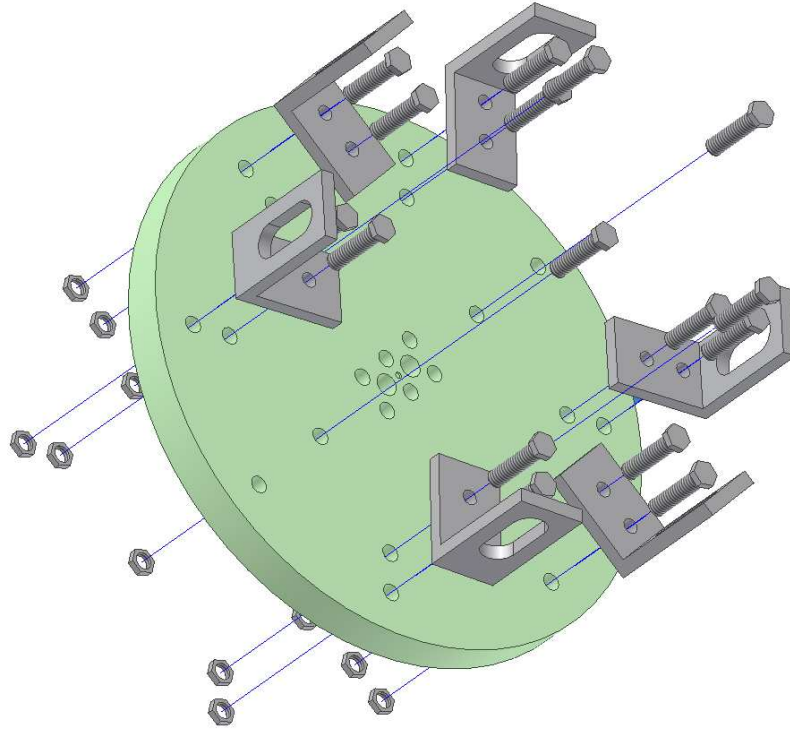

Figure 1

Step 2:

Needed Part Numbers: Assembled [1, 3, 17]

New parts: 6, 10, 18

Required tools: 1 crescent wrench

Required Materials: Vacuum Grease

- a.) Remove parts 6, 10, 18 from their respective packages and inspect each part for damage.
- b.) Identify part 10, O-ring, and apply thin layer of vacuum grease on to the O-ring. Take part 6, Stainless Steel Jacket and Flange, and identify the O-ring channel. This is the channel that part 10, O-ring, fits into as shown in figure 2. Place part 6, O-ring, into the identified channel as shown in figure 2.
- c.) Line up the four holes on part 1 with the four holes on the Stainless steel flange on part 6 as shown in the figure 2. Place bolts through the lined up holes from part 1 first to part 6. Screw on matching nuts and tighten.

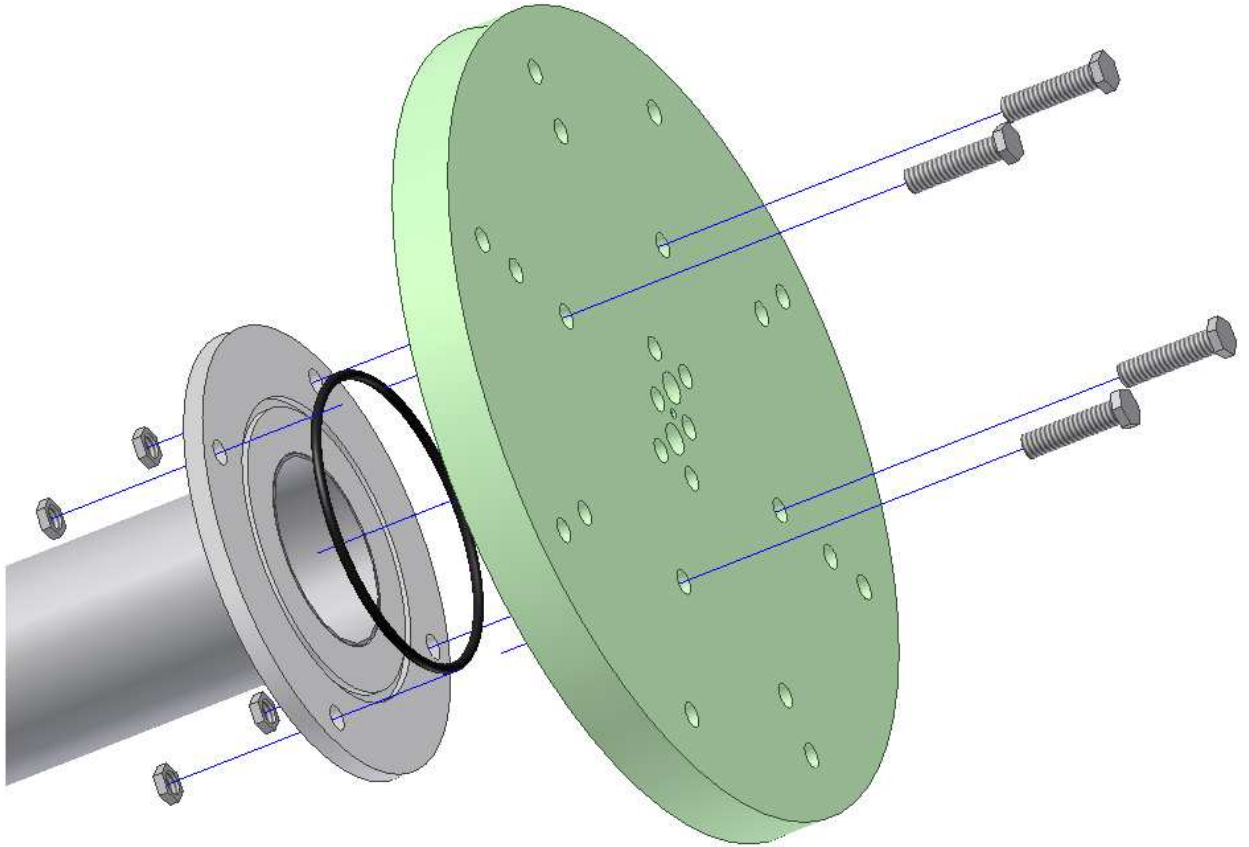

Figure 2

Step 3:

Needed Part Numbers: Assembled [1,3,17,6,10,18]

New parts: 2, 4

Required tools: 1 Crescent wrench

- a.) Remove parts 2 and 4 from their respective packages and inspect each part for damage.
- b.) There are six identical items to part 2, current leads. These leads are labeled 1 through 6 near the bend at the top. Orient the current assembly as shown in figure 3. Place lead 1 in top left corner hole as shown in figure 3 and push through till the bend is approximately in the middle of part 3 as shown in diagram figure 3. Do the same for leads 2 through 6 following the numbering on diagram figure 3.
- c.) Orient each of the leads pointing towards their respective Aluminum angle brackets as shown in diagram figure 3. Once part 2 is in this orientation take the nuts from part 4 and put one on each of the leads. Then take part 4, leading with the threaded end, put the threaded part through the slot in part 3 and insert part 2 in to the hole in part 4

as shown in figure 3. Once on tighten nut. Solder the copper rod to the current connect.

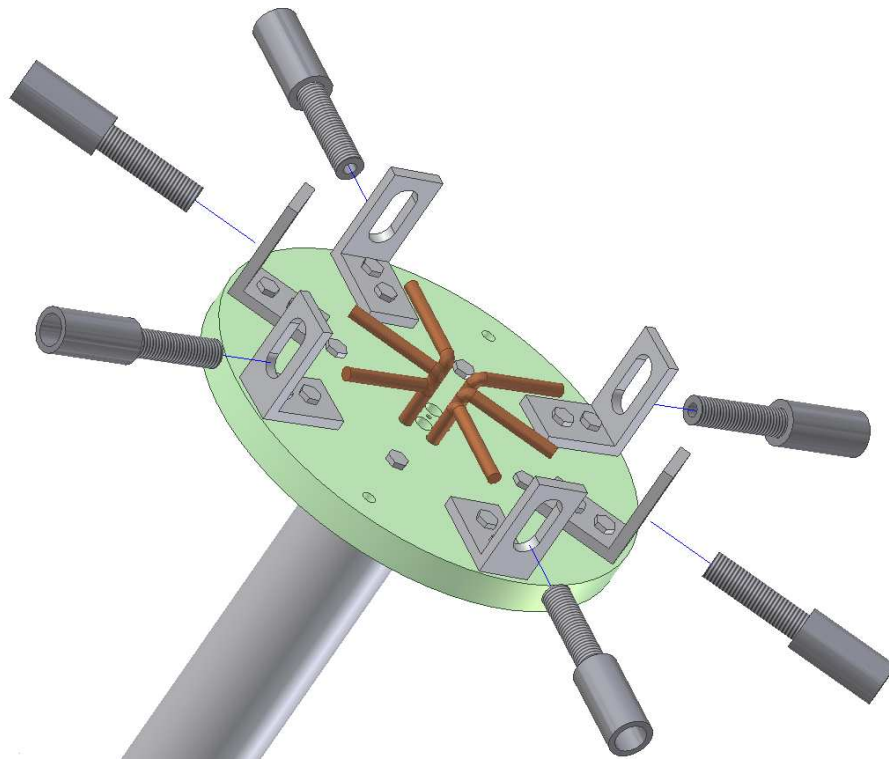

Figure 3

Step 4:

Needed Part Numbers: Assembled [1,2,3,4,6,10,13,17,18]

New Parts: 8,9,19,13

Required tools: 1.5' long rod, Allen wrench

- a.) Remove parts 8, 9, and 19 from their respective packages and inspect each part for damage.
- b.) Take one of the G-10 spacers, part 8, and match holes to the copper leads. Push this spacer down into the stainless steel tube, part 6, until it is flush with the tubes entrance. Then using a 1.5 ft long rod push the spacer in until the end of the rod is flush with the entrance of the tube.
- c.) Next take part 9 and line up the copper rods with the holes on part 9. Slide part 9 down into the stainless steel tube until the tubes' entrance is flush against the ring protrusion in the middle of part 9.
- d.) Now place eight of part 19 into the holes where part 6 and part 9 match up. Screw these down tight until the screws are just below the surface.

e.) Finally take part 13 and match the holes with the copper rods. Slide part 13 down the copper rods until it is approximately 6in from part 9.

****NOTE:** It is recommended that step five and six are performed by an individual with great experience in soldering, prepping, and handling of YBCO. Step five and six are delicate assembly procedures developed at the ASC. Much experience is needed in order to not damage the heat sensitive YBCO leads, part 11. If attempted without prior experience with YBCO damage to the YBCO leads is likely.

Step 5:

Needed Part Numbers: Assembled [1,2,3,4,6,8,9,10,13,17,18,19]

New Parts: 11,12,14,22

Required tools: Inductance heater, solder, flux, table support for probe, fine grit sand paper, alcohol

- a.) Remove parts 11 and 12 from their respective packages and inspect each part for damage.
- b.) Clean inside of part 12 channels, noted in figure 4, with fine grit sand paper and alcohol. Pre-tin inside of channels with solder.
- c.) Put generous amounts of flux inside pre-tin channels of part 12 and on one end of YBCO conductor. Place flux coated end of YBCO in channel making sure it is straight. Heat with inductance heat making sure not to exceed 200 °C. Repeat this step for all channels and YBCO conductors.
- d.) Finally attach bottom spacer according to figure 4. Insert part 22 in two holes shown in figure 4. Tighten until screw is below surface of the bottom spacer.

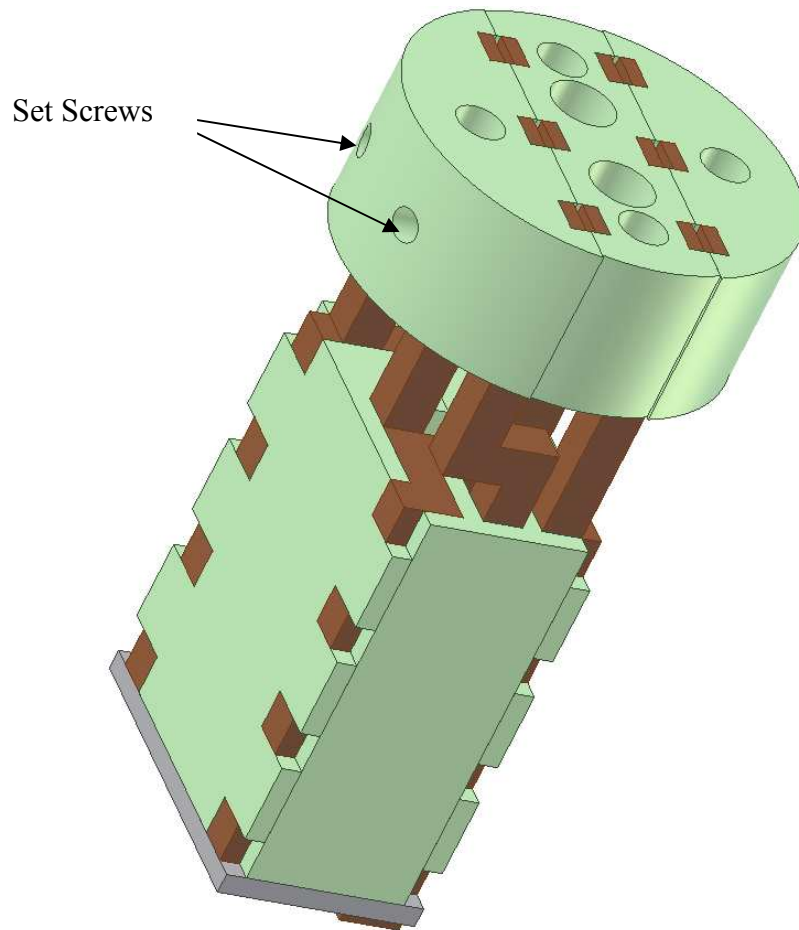

Figure 4

Step 6:

Needed Part Numbers: Assembled [1-4,6,8-14,17-19]

New Parts: None

Required tools: Inductance heater, solder, flux, table support for probe, fine grit sand paper, alcohol

- a.) Clean inside of part 2 channels, noted in figure 5, with fine grit sand paper and alcohol. Pre-tin inside of channels with solder.
- b.) Coat the inside of part 2 channels with generous amounts of flux as well as the exposed end of part 6.
- c.) Insert all of part 6 into the respective channels of part 2 as shown in the figure 5.
- d.) Use inductance heater on each joint, making sure not to heat over 200 °C, until solder has melted. Final produced as viewed in figure 5.

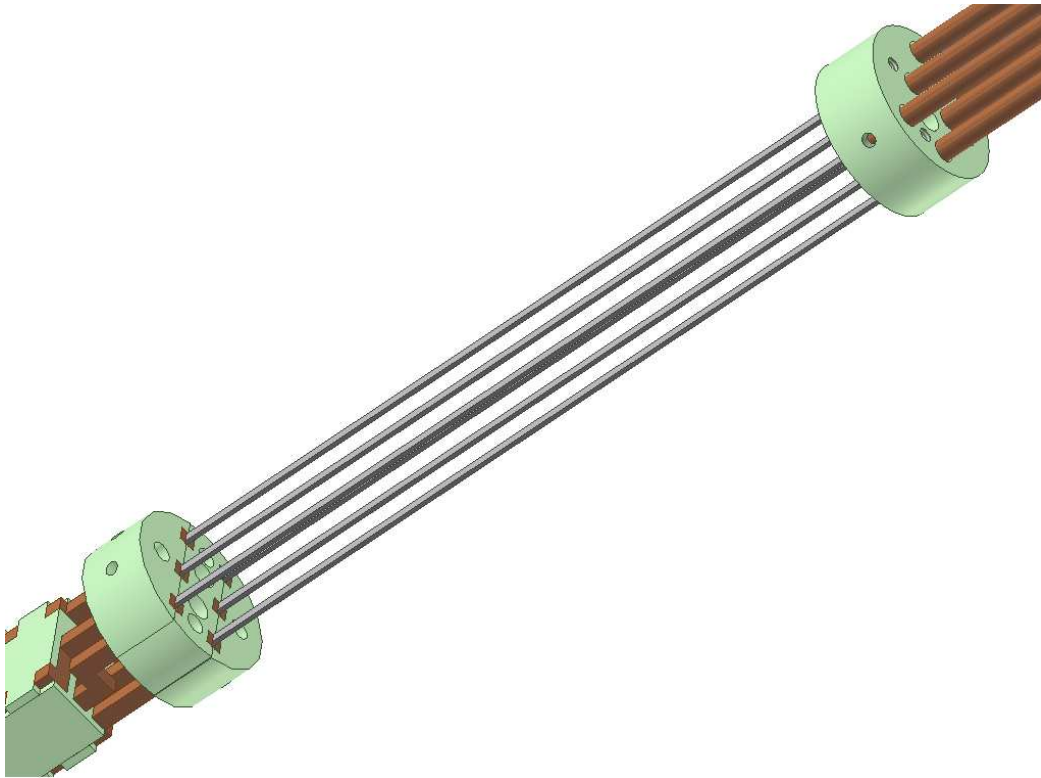

Figure 5

Step 7:

Needed Part Numbers: Assembled [1-4,6,8-14,17-19,22]

New Parts: 7,15,16,19,23

- a.) Remove parts 7, 15, 16, and 23 from their respective packages and inspect each part for damage.
- b.) Put part 15 in to designated hole in the bottom spacer, as shown in figure 6, till it touches sample holder. Once in the hole align and screw in opposite end in to the top spacer. Then screw on nut from part 15 package. Do this for each support rod.
- c.) Next insert the sample holder, part 12 into part 7 at the end when there are holes in the side wall. Carefully slide part 12 over the sample holder and over the HTS lead till the holes in part 12 match up with the holes in part 9 as shown in figure 6. Then screw in the rest of part 19 into each of the holes, tighten until below surface.
- d.) Then thread part 23 into each of the three holes located on the bottom of the sample holder. Take three of the six nuts provided and screw them on half way up the threaded rods. Then with the larger face of part 16 facing the bottom of the sample holder align the holes of part 16 with the threaded rods and slide on till in contact

with the nuts on the rods. Finally screw on the other three screws on to each of the rods and tighten.

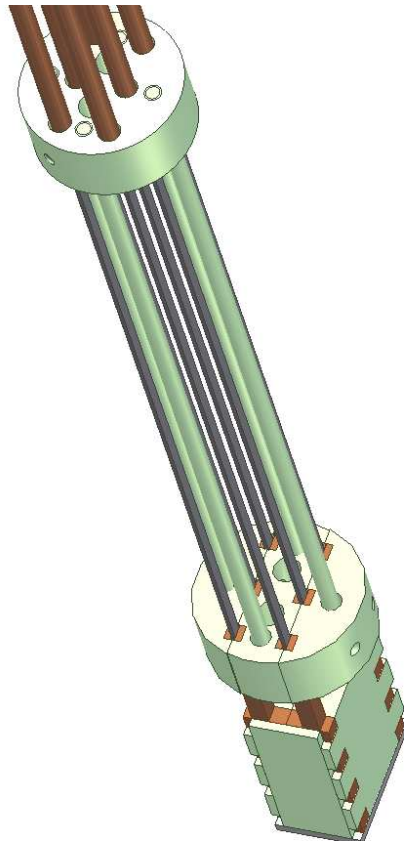

Figure 6

Step 8:

Needed Parts Assembled: [1-4,6-19,22-23]

New Parts: 5,20,21

- a.) Remove part 5 from its package and inspect the part for damage.
- b.) Place part five through either of the two holes shown on figure 7. Insert until there is about 7in of space between the top of the instrumentation flange and the surface of part 1.
- c.) Next take part 20 and mix the two components in a small mixing container. Use a q-tip to spread part 20, Stycast, around each of the copper leads and instrumentation tube, parts 2 and 5 respectively, at the base where parts 2 and 5 enter into part 1. This is to seal and plug up any gaps between part 2, 5, and part 1. Let the Stycast cure for 24hrs before use.
- d.) Finally take part 21 and stick it in the designated hole as shown in diagram. Push to where part 21 will not let and air escape.

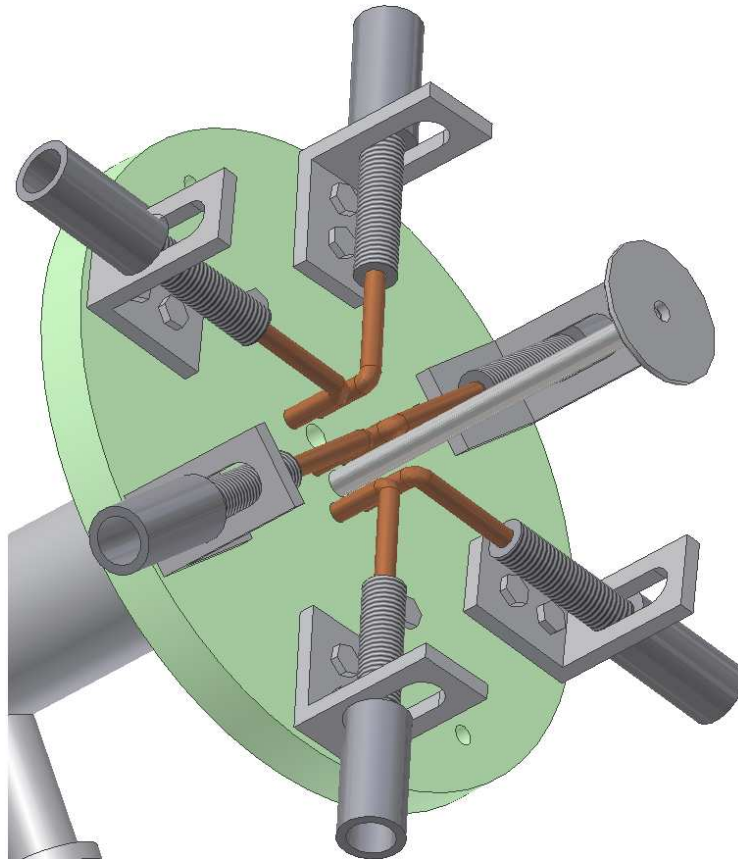
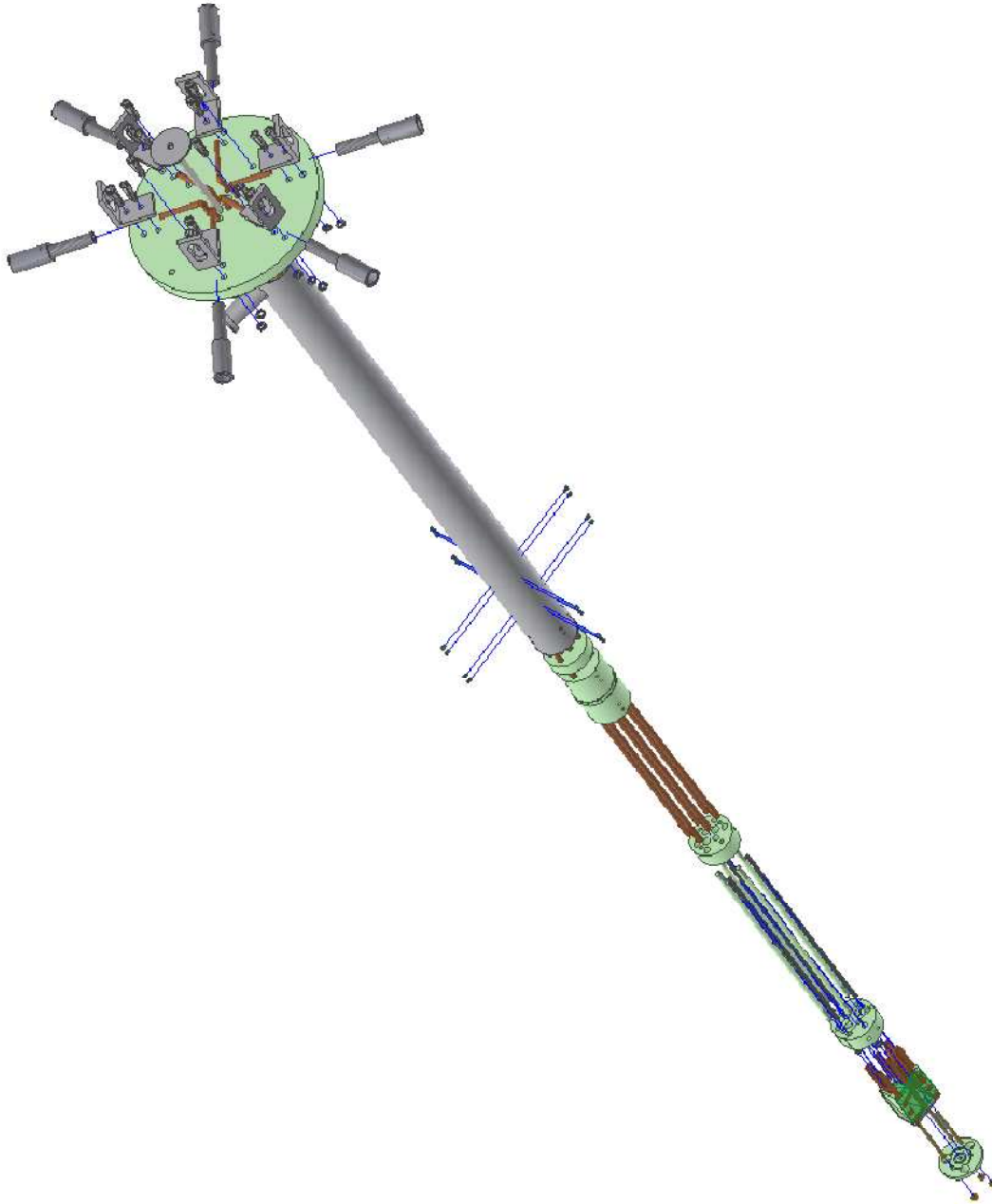

Figure 7

Exploded View



Bill of Materials

Company	material	quantity	cost
Speedy Metals	110 Alloy Copper rods	6	\$291.00
K-mac-plastics	G-10 Tube	1	\$611.04
Acculam	G10 Plate	1	\$88.24
McMaster-Carr	Stainless steel plate	1	\$81.49
McMaster-Carr	G10 rod	1	\$125.77
McMaster-Carr	G-10 plate	1	\$67.40
McMaster-Carr	90deg angles steel	1	\$44.06
Multi-Contact	Sockets threaded, current connects	6	\$180.00
McMaster-Carr	copper plate	1	\$60.95
McMaster-Carr	copper bar	1	\$62.52
McMaster-Carr	G-10 Plate	1	\$60.18
McMaster-Carr	aluminum bar	1	\$49.34

McMaster-Carr	cartridge heater	7	\$247.24
McMaster-Carr	Bolts, Nuts, Screws, rubber stopper	multiple	\$40.52
McMaster-Carr	wing nut	1	\$11.21
McMaster-Carr	compression springs	2	\$26.72
Exotic Machining	G-10 Sample holder parts	1	\$400.00
		Total	\$2,447.68

**NOTE: The YBCO leads were custom made at the ASC for this probe at a cost of \$65/m using 19.2m.

Environment, Health, and Safety Precautions

The assembly, manufacturing, preparing, and testing of this critical current probe was not without a few toxic chemicals and hazardous activates that will be discussed in the following pages.

Toxic Materials/ Harmful Devices

- **G-10**
G-10 is a glass based epoxy resin and is made by producing thin cloth like layers and stacking them atop on another in order to be heated to form a solid, fibrous, composite structure.



Figure 8

The primary benefit of G-10 is its very low thermal conductivity and good insulation, which is valued with working in cryogenic conditions that require little to no heat transfer from the surrounding air. In this project G-10 was used as spacers to keep the current leads from contacting one another within the steel casing and to hold together the sample holder located at the bottom of the probe. These parts required machining and as a result G-10 dust was kicked up into the air from grinding down or drilling holes into. Because of its abrasive fibrous nature, G-10 dust can damage the lungs if inhaled and over time could even cause serious forms of cancer. This is why a face mask was used on whoever was handling G-10 in this manner.

- **Flux**

Flux is a chemical used in soldering that helps prevent oxidation and acts as a wetting agent that helps keep the contact of the solder to the material.

Flux was used in the project to solder together a total of 48 strands of HTS (High Temperature Superconductor) into 6 different strips. Flux is very toxic in itself that its fumes,

when inhaled, can cause occupational asthma and its

chemical composition can be very harmful to humans. This is why when working with flux, gloves, goggles, and ventilation were always used.



Figure 9

<http://www.mcmelectronics.com/product/CAIG-LABORATORIES-RSF-R80-2-/200-385>

- **Cutting Fluid**

Cutting fluid was used when machined metal in order cool down the constantly heated drills. This was probably the least concerning chemical agent, but it was necessary to avoid contact by properly washing of the material of the cutting fluid. Cutting fluid can irritate the skin due to its chemical composition and synthetic fluids are also hosts to growing bacteria as they can capture dust, hair, and skin that regularly fall off people.

- **Machining Hazards**

The machines used to create the parts also came with their own hazards. This ranged from bits of metal flying off the mills to proper use of the equipment. This was easily avoided by wearing gloves and eye protection where appropriate and using caution around the machines.

- **Heating Hazards**

Large Aluminum blocks were used to heat the leads and HTS tapes in order to form a complete soldering of our materials. Because of the delicate nature of the HTS tapes a controlled temperature was needed between 190 and 200 Degrees Celsius to melt the solder, but not damage the HTS leads. This specific temperature was achieved by using cartridge heaters, long cylindrical rods that when attached to a voltage source it outputs large amounts of heat. The cartridge heaters were attached to a temperature control device that would not allow the aluminum blocks to go over a certain temperature. These high temperatures were represented in the aluminum which would easily burn the skin if one was not wearing furnace gloves to properly handle them.



Figure 10

Preparing Safety Precautions

- **Handling of Liquid Helium/Nitrogen Dewar**
As stated many times before, liquid nitrogen and oxygen are necessary in order to complete our experiment and to obtain results. Due to the highly compressed nature of these two fluids, the temperatures reach 77 Kelvin and 4.2 Kelvin for Nitrogen and Helium respectively and both must be stored in large dewars as shown below. To prevent the rapid expansion of air, a vacuum layer between the liquid agent and the air in the dewar is required to hinder any heat being transferred in. If one is transporting a dewar, large, well ventilated areas must be accessible at all times or suffocation from



Figure 11

<http://ntl.snu.ac.kr/facilities.php>

the removal of air by the helium or nitrogen gas may result. The freezing temperatures of the liquids and gas must also be watched and must never come into contact with skin at any time. Any contact will result in freezer burn/frostbite or loss of limb.

- **Electric Current**

To test the samples, an upwards of 1,000 amps of electrical current can run into any of the 6 top connectors and down through the connecting current leads. While the test is being run, absolutely no contact must come within the testing probe in general as to avoid a deadly electric shock.

- **Weight**

The Critical Current Probe can weigh an upwards of 50 to 100 pounds and must be lifted with a small crane in order to fit within the cryostat. Avoidance of the probe during lifting was taken in order to reduce the chances of the crane falling and causing harm.