

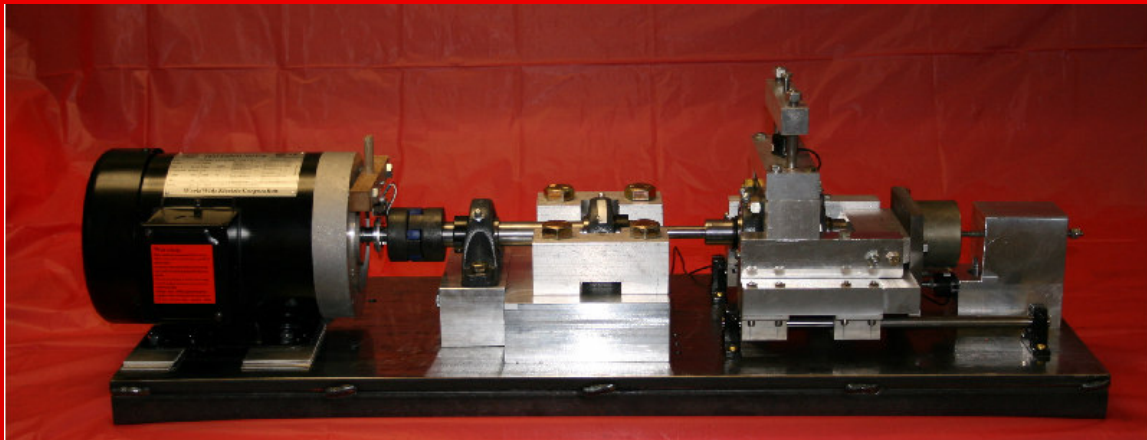

Cummins 2



Fatigue Tester



Department of Mechanical Engineering
EML 4551 Senior Design Project
Dr. Cesar Luongo

Design Report
Submission date: April 9, 2007

Team 11

Members:

Robert Graves
Coby W. McColgin
Robert Nichols II
Brett Van Hazel

Graduate Assistant: Kevin Garvey



Abstract

Metal fatigue is a major cause of failure in automobiles. Unfortunately, metal fatigue remains difficult to predict and model. Cummins Inc., a world leader in engine development, has asked how rotating bending fatigue data can be used to properly predict the fatigue life of the gray cast iron used in some of their engine cylinder blocks. These cylinder blocks experience bending fatigue, tensile fatigue, and a combination of both. After careful consideration it was determined that data gathered from tests that performed bending fatigue and tensile fatigue simultaneously would be necessary to answer the aforementioned question.

A partially operational prototype combination fatigue tester was designed and built. Completion of the prototype and development of a full scale (full power) combination fatigue tester is necessary for the continued progress of this project. Once fully developed, data from tests should be used to create an empirical model. The empirical model should then be compared with the theoretical model to see if any trends exist. The report details the prototype's design process and the conclusions that were drawn from this project.

Table of Contents

Abstract	3
Table of Contents	4
I. Introduction	6
Project Statement	7
Project Plan	7
II. Background Research	9
Fatigue Testing.....	10
Description:.....	10
Endurance Limit:	10
Tensile Fatigue Testing.....	11
Rotating Bending Fatigue (RBF) Testing.....	11
Current Test Methods and Existing Products	12
III. Design Generation	16
Concept Generation	17
Design/Method 1.....	17
Design 2	18
Design 3	19
Design 4	20
Design Concept Selection.....	21
Decision Matrix:	21
Decision:	22
Vertical Load Assembly Concept Generation:	23
Design 1	23
Design 2	24
Design 3	25
Vertical Load Assembly Selection Decision Matrix	26
Tensile Fatigue Selection.....	27
Design Modifications.....	29
Final Design	32
Component Breakdown	34
IV. Project Results	39
Project Summary.....	40
Tensile Load:	41
Vertical Load:	42
Optical Encoder:	42
Problems and Solutions.....	43
Problems:	43
Solutions:	43
Recommendations.....	44
Appendix A: Bill of Goods	46
Appendix B: Cost Analysis.....	48
Appendix C: Circuit Diagram.....	51
Appendix D: Exploded Views & Engineering Drawings	53
Appendix E: Catalog Pages for Selected Parts	104

Appendix F: Calculations	114
Appendix G: Bibliography.....	129
Appendix H: Operations Manual.....	131
Purpose.....	133
Safety Precautions.....	133
Test Procedure	134
How to run a test.....	134
 Safety Instructions 	140
USB-6009 DAQ Board Channel Configuration	140
Connecting sensors to the USB-6009 DAQ Board.....	141
LabVIEW Virtual Instrument Software.....	143
Running the LabVIEW Virtual Instrument Software	144

I. Introduction

Project Statement

Determine how Rotating Bending Fatigue (RBF) test results relate to the fatigue life of a material that experiences tensile forces, bending forces and combinations of both.

Project Plan

- *Proposed Solution:*
Construct a machine that performs RBF, Tensile Fatigue, and a combination of both.

- *Project Design Specifications:*
 - *Functional Performance –*
 - AC Motor 1800-3600rpms
 - Tensile Load 30-60Hz
 - Maximum Load of 1400lbs. tensile load
 - Maximum Load of 30lbs. bending load
 - Run one test to 10 million cycles in less than one week
 - Be capable of providing data to create an empirical model
 - *Physical Requirements –*
 - Capable of fitting on a 3' x 6' table top
 - Weight should be less than 200 lbs
 - *Life Cycle Issues –*
 - Machines useful life should extend past 10 million cycles
 - Machine should be easy to maintain and repair
 - Safely perform Rotating Bending and Tensile testing throughout the life of the machine

- Project Scope:

The scope of this project is to begin the process of designing and building a machine capable of performing RBF testing, Tensile Fatigue testing, or a combination of the two tests. Research will be conducted on RBF and Tensile fatigue testing, current testing methods, and existing products. Once a better understanding of the problem statement has been reached a solution will be proposed and design concepts will be generated. A design will be selected using a decision matrix and the design will be modified until a final design has been achieved. A cost analysis for the final design will be generated and turned in for approval. On approval all parts will be ordered and detailed part drawings will be created for all parts that need fabrication. As the parts come in they will be machined if necessary and the machine assembly will begin when all the parts have been received. Problems in machine assembly will be corrected as they occur and they'll be addressed in the report. All electrical components will be tested and integrated into Lab View. Testing and data acquisition for an empirical model will be performed if time permits. An operation manual will be created for our machine that will provide basic operating instructions necessary to run and maintain the machine. All the information for this project will be compiled into a final report and finalized for distribution.

II. Background Research

Fatigue Testing

Description:

Fatigue is the loss of strength and energy resulting from physical work. Fatigue testing is the applying of continuous loading to a test specimen in order to determine how it performs under repeated vibration or strain conditions. The fatigue life of the specimen is the number of cycles of fluctuating stress and strain that a specimen can withstand before failure occurs. The fatigue life will change for each specimen because it's dependant on the magnitude of the fluctuating stress, the specimen geometry and testing conditions.

Fatigue behavior is classified into two domains, high cycle and low cycle fatigue. High cycle fatigue is associated with low strain conditions and fatigue lives greater than 10^4 to 10^5 cycles. High cycle fatigue creates stress levels that are under the yield strength of a given material. It results from vibrations or strain from high cycles that can reach thousands of cycles per second, at frequencies that can be induced by many sources. Low cycle fatigue is associated with high vibration or strain conditions. Low cycle fatigue failure generally occurs in relatively small number of fatigue cycles less.

Three distinct steps characterize the fatigue failure process. The first is crack initiation; this is when a small crack forms at some point of high stress concentration on specimen. The second is crack propagation; this is the advancement in crack size with each stress cycle. The final step is failure; once the advancing crack reaches a critical size failure occurs.

Endurance Limit:

- **Description** - a limit below which repeated stress does not induce failure, theoretically, for an infinite number of cycles of load. The limit of a material is affected by different factors.
- **Endurance Limit Factors:**
 - **Surface Condition:** such as: polished, ground, machined, as-forged, corroded, etc.
 - **Size:** This factor accounts for changes which occur when the actual size of the part or the cross-section differs from that of the test specimens

- **Load:** This factor accounts for differences in loading between the actual part and the test specimens
- **Temperature:** This factor accounts for reductions in fatigue life which occur when the operating temperature of the part differs from room temperature
- **Reliability:** This factor accounts for the scatter of test data
- **Miscellaneous:** This factor accounts for reductions from all other effects, including residual stresses, corrosion, plating, etc.

Tensile Fatigue Testing

Tensile or axial fatigue testing (Figure 2-1) is a common method used to determine mechanical properties of metals, such as Young’s modulus, tensile strength, modulus of elasticity, tensile strength, and other tensile properties. Tensile loading is used to determine how a material will behave under axial stretch loading. In Tensile Fatigue testing a continuous small axial load is applied constantly so that the fatigue limit of a specimen can be determined. Methods for tension tests for metals can be seen in the ASTM E 466-82 (Appendix G).

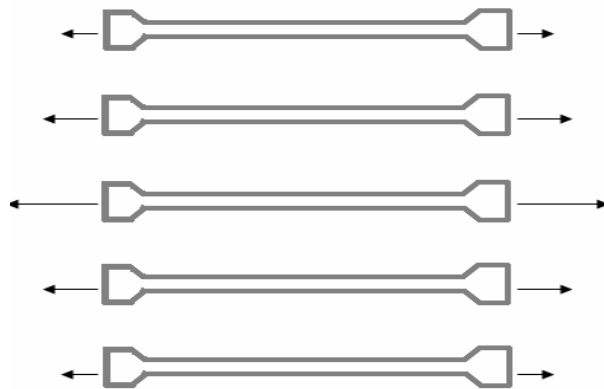

Figure 2-1: Tensile Loading

Rotating Bending Fatigue (RBF) Testing

RBF is an example of fully-reversing load which is when a specimen is put under tensile stress then released, then its put under compressive stress of the same value and then released. RBF can be visualized as a shaft in a fixed position but subjected to an applied bending load (Figure 2-2). The outermost fibers on the shaft surface on the convex side of the deflection will

be loaded in tension (upper green arrows), and the fibers on the opposite side will be loaded in compression (lower green arrows). The shaft will rotate 180° with the loads remaining constant. The shaft stress level stays the same but the fibers which were loaded in compression will now be loaded in tension, and vice-versa.

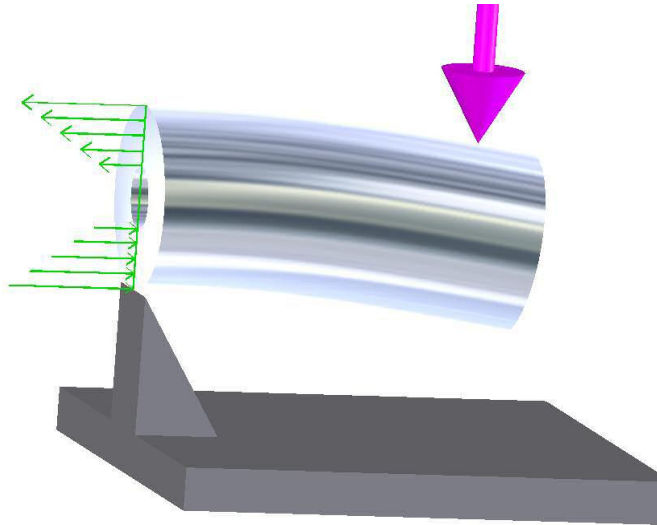

Figure 2-2: Rotating Bending
Image from www.epi-eng.com

Current Test Methods and Existing Products

Fatigue test results are generally plotted into an S-N plot (Stress versus number of cycles to failure). A series of test are commenced by subjecting a specimen to the stress cycling. Starting at high stress amplitude the number of cycles to failure is counted. The procedure is repeated on other specimens at progressively decreasing stress amplitude. Data is then plotted into an S-N plot (example seen in Figure 2-3).

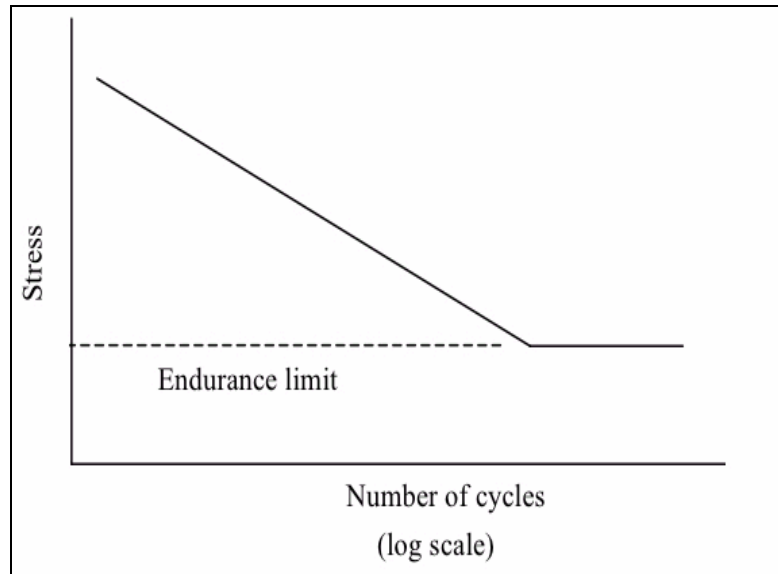

Figure 2-3: S-N plot

Cummins currently use Rotating Bending Fatigue test, to establish bending fatigue data. Tests are performed on machines that are similar to the Instron RRM-A1 (Figure 2-4). The specimens are tapered on the ends to match the tapers within the spindles of the machine, which are threaded to be held in place. The machine operates by applying stress through a direct application of weight to the specimen while it is in rotation. This gives the device an accurate and easy way to measure the bending load. The image below shows the Instron RRM-A1.



Figure 2-4: Instron RRM-A1

Image from www.instron.com

Cummins uses the staircase method of analysis to generate their fatigue data. The method is efficient because test results concentrate mainly on three stress levels, which are centered on the mean stress level. Some disadvantages to this method are: only one specimen may be tested at a time, also it is a bad method for estimating small or large percentage points unless there is normal distribution.

Staircase Procedure:

1. The first test is performed, at a stress level equal to an estimated average value of the fatigue strength of the material.
2. If there is failure in the specimen from test one prior to the assigned cycle life, then the next specimen is tested at a lower stress level. However if failure does not occur within the assigned number of cycles, then the next specimen is tested at a higher stress level.
3. The testing continues in the process of the stress level being raised or lowered depending on the preceding test results.
4. After all specimen testing is complete take data and generate graph.

The MTS Servohydraulic Machine (Figure 2-5) is used for tensile testing. The machine can be used for both high and low cycle fatigue testing. Hydraulic actuators are used to apply a

continuous axial load. This tensile fatigue tester subjects the specimen to a uniform stress or strain through its cross section.

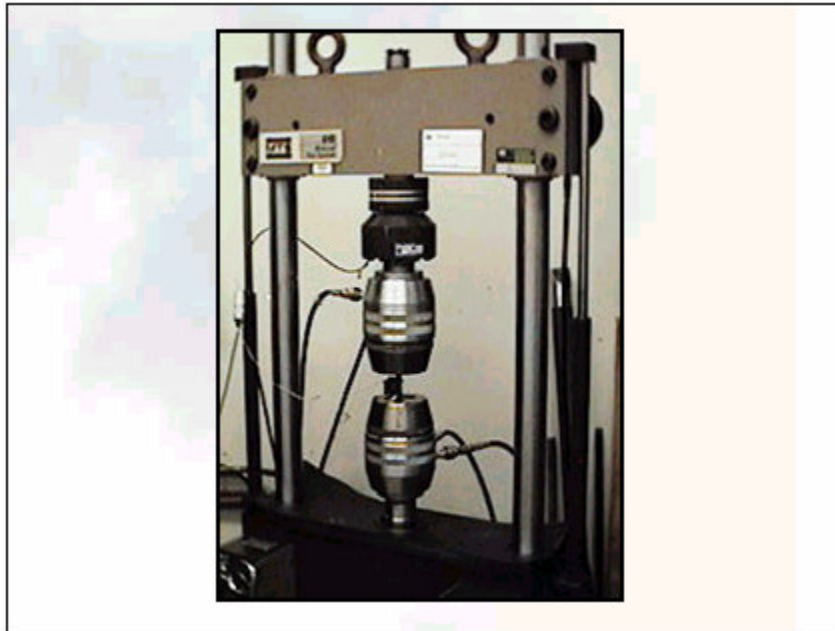

Figure 2-5: MTS Servohydraulic Machine
Image from www.coiledtubingutulsa.org

III. Design Generation

Concept Generation

Design/Method 1

The first method to be discussed utilizes the rotating bending machine (Figure 1) located in the FAMU/FSU College of Engineering materials lab as well as the tensile fatigue tester located at the National High Magnetic Field Laboratory. In order to produce a combined loading effect specimens would likely need to be tested on the tensile fatigue tester for a predetermined number of cycles and then placed in the rotating bending fatigue tester for a predetermined number of cycles.

Disadvantages of Design/Method 1:

- Rotating bending fatigue tester has proven to be unreliable and currently has many components that are inoperable or unreliable.
- Rotating bending fatigue tester and tensile fatigue tester require different grips for specimens.
- Access to both laboratories is limited to normal business hours Monday through Friday.
- This method is not a true combined loading test.

Advantages of Design/Method 1:

- Testing and data acquisition could be started as soon as specimens and grips are obtained.
- Note: Assuming simple/quick repairs for the rotating bending fatigue tester.
- Both machines meet speed and load requirements.
 - Both machines meet ASTM requirements.
 - Tests could be run in a secured area.



Figure 3-1 from www.terco.se

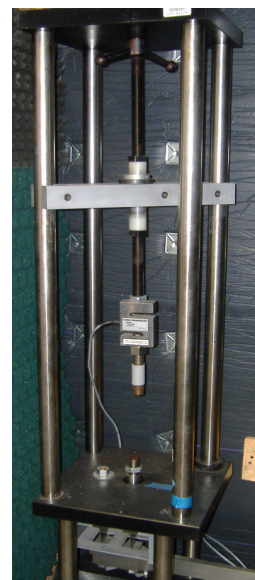

Figure 3-2

Design 2

Design 2 attempts to combine tensile fatigue testing and rotating bending fatigue testing capabilities into one platform. Tensile loads and bending loads would be applied at one end of the specimen. The bending load would be applied via a concentrated force. The opposite end of the specimen would be constrained in order to allow no horizontal translation. This end would be rotated, most likely by a motor.

Disadvantages of Design 2:

- Machine must be constructed.
- Construction would require tight tolerances.
- Funding may not be sufficient for necessary materials and components.
- Data acquisition capabilities must be addressed.
- Tensile Loading and Bending Loading methods must be addressed.

Advantages of Design 2:

- True combined loading tests would be capable of being conducted.
- Machine would likely have no restrictions for accessibility
- Machine can be made to meet all requirements.
- Simple in design.

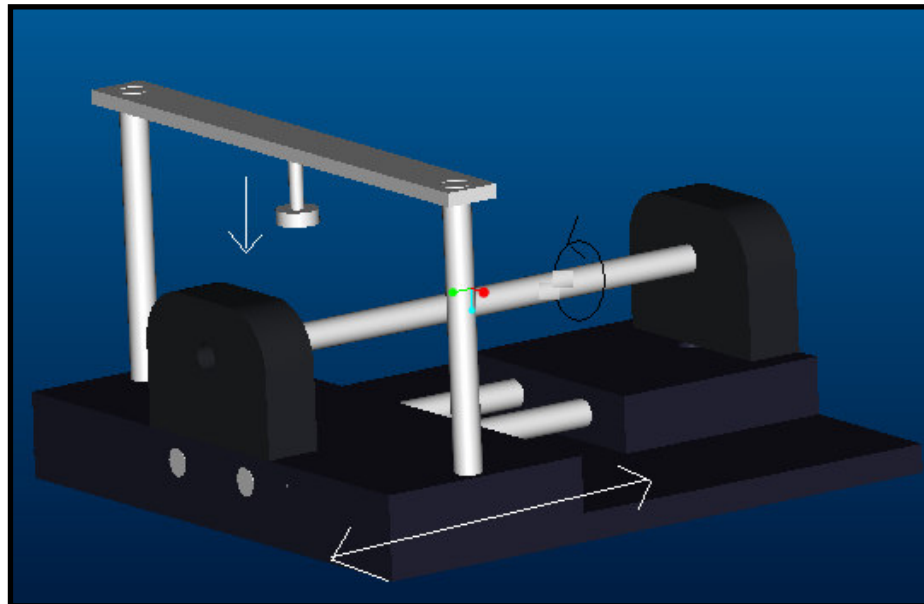

Figure 3-3

Design 3

Design 3 is an adapted version of a schematic drawing in the Foundations of Materials Science and Engineering textbook (Smith/Hashemi, 2006, 7). A layout of the design can be viewed in (Figure: 3-4). While the principal is the same as the other designs it is the bending force applied that makes this design unique. While the other designs utilize a concentrated force to induce bending this design utilizes moments. Equal but opposite moments applied at opposite ends of the specimen produce a bending force in the middle of the specimen.

Disadvantages of Design 3:

- Machine must be constructed.
- Construction would require tight tolerances.
- Funding may not be sufficient for necessary materials and components.
- Data acquisition capabilities must be addressed.
- Tensile Loading method must be addressed.
- Extensive Dampening would be required as bending load would be constantly moving.
- Complexity of moving parts causes concerns.

Advantages of Design 3:

- True combined loading tests would be capable of being conducted.
- Machine would likely have no restrictions for accessibility
- Machine can be made to meet all requirements.

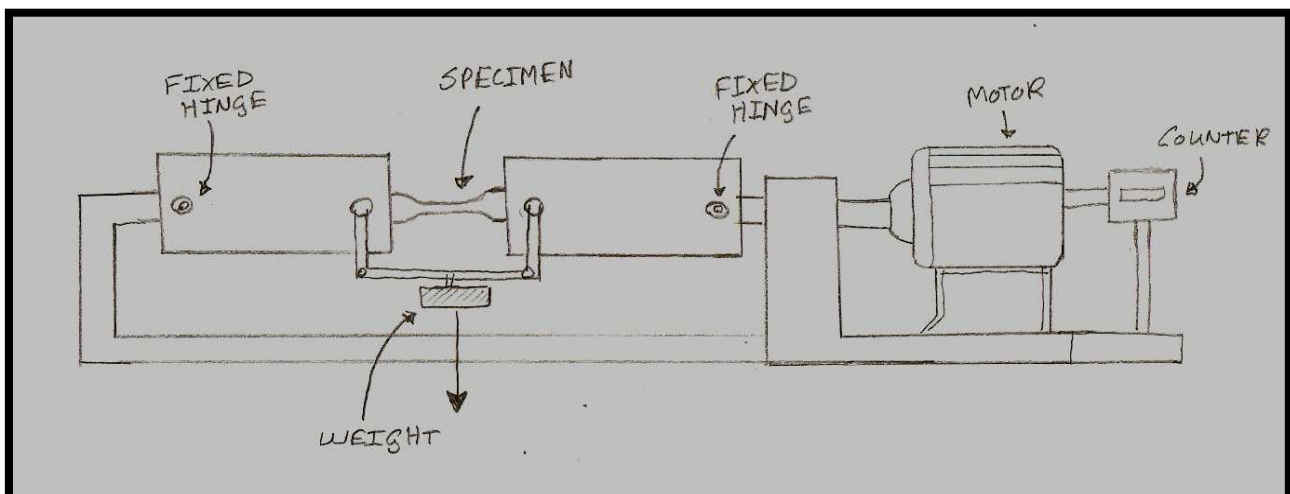

Figure 3-4

Design 4

Design 4 as seen in (Figure: 3-5), is similar to designs 2 and 3 as it is designed to test the Rotating Bending Fatigue as well as tension fatigue of a specimen simultaneously. The bending load would be applied via a concentrated force applied in the middle of the specimen. The tensile load would need to be applied through equal and opposite forces on both ends of the specimen. This is necessary in order to ensure that the bending force is applied at the same point through out the span of a test.

Disadvantages of Design 4:

- Machine must be constructed.
- Construction would require tight tolerances.
- Funding may not be sufficient for necessary materials and components.
- Data acquisition capabilities must be addressed.
- Tensile Loading and Bending Loading methods must be addressed.
- Applying equal and opposite forces to the specimen presents difficulties.

Advantages of Design 4:

- True combined loading tests would be capable of being conducted.
- Machine would likely have no restrictions for accessibility
- Machine can be made to meet all requirements.

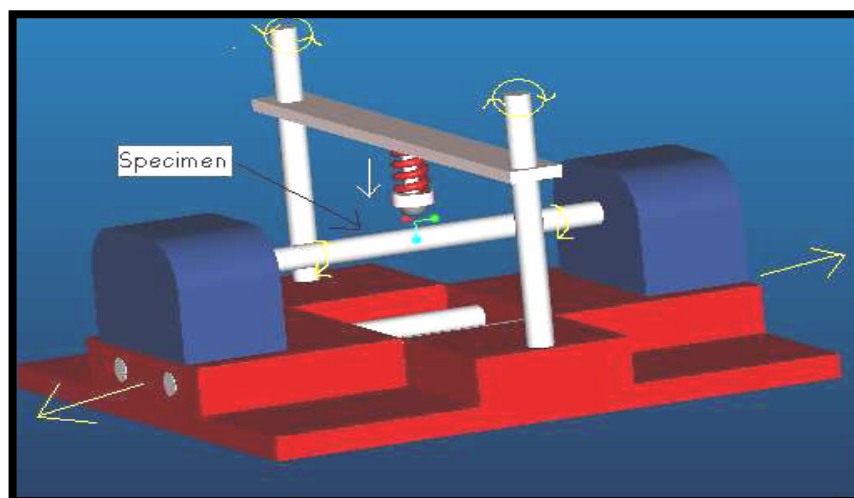

Figure 3-5

Design Concept Selection

Decision Matrix:

Once our designs were completed, we needed to determine which one suited our needs the best. The first step was to create a decision matrix (see Figure 3-7) to help our group choose a design. The categories we based on a total of one and the decision matrix was broken down into cost, safety, reliability, ease of use, and performance.

Cost (0.2): These scores were based on the expected cost to construct or implement each design concept relative to the other concepts. This category received a weight of 0.2 due to a fixed budget.

Safety (0.1): These scores were based on the imagined risk to a trained operator, using the equipment for its intended purpose. This category was not heavily weighted as operators are expected to be well versed in using the machine.

Reliability (0.25): Reliability was based on the projected amount of maintenance required (least amount of maintenance receives highest score). This category is the second highest weighted category due to the nature of the testing to be performed on the machine (high cycles). Near-continuous operation is expected. Any time spent fixing the device is time lost to testing as well as the possibility of failure during testing.

Ease of Use (0.05): Ease of use is based on the ease of inserting and removing specimens as well as operator access to machine and power supply. Additionally, the ease of adjusting the magnitude and frequency of the tensile and rotating-bending loads was considered. A low rating was given to ease of use for similar reasons as safety.

Performance (0.4): Performance was based on the expected ability of a design to perform repeated valid fatigue tests in a timely manner. Performance received the highest weight because valid data is crucial to the overall objective of this project.

Condition	Cost	Safety	Reliability	Ease of Use	Performance	Total
Weight	0.2	0.1	0.25	0.05	0.4	1
Design						
1	4	3	2	4	2	2.6
2	2	3	3	3	4	3.2
3	3	3	3	4	2	2.65
4	2	3	3	3	3	2.8

Figure 3-6

Decision:

After analysis of each design it was concluded that design 2 (Figure 3-7) would be pursued. It was projected that design would provide the best performance of the four designs. Design 2 also received high scores for safety, reliability, and ease of use. Cost was the only concern for design 2 however it was determined that the \$2000.00 budget was sufficient for the purchasing of all components.

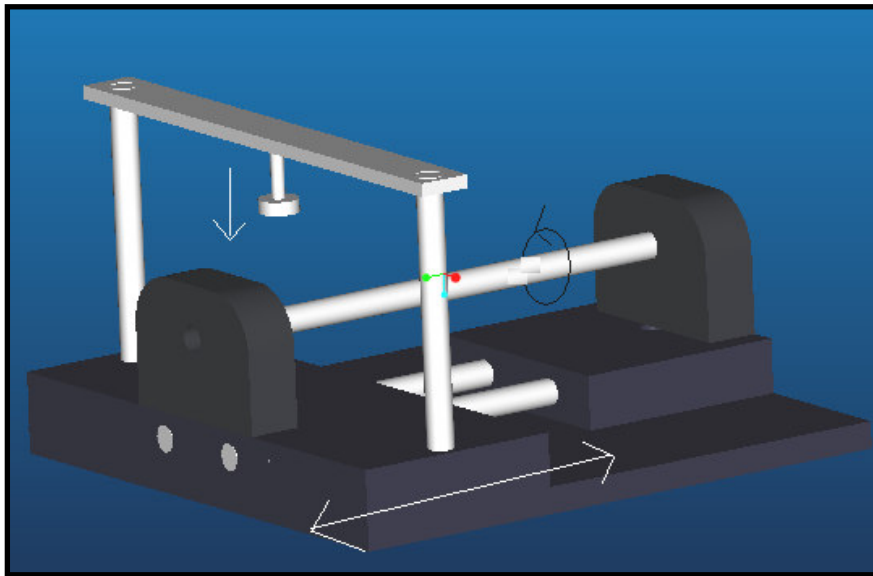

Figure 3-7

Major Component Selection

There were two key sections of the design concept that needed to be determined in greater detail before proceeding to a final design. These were the ability to apply a vertical load (for rotating-bending), and the ability to apply a tensile load (for the tensile loading). The following sections outline our method selection for these two sections.

Vertical Load Assembly Concept Generation:

Design 1

This design utilizes springs to apply the load. A central gear on top of the apparatus would be manually turned. The central gear would then rotate two smaller gears at the same rate. These gears would each then turn a threaded rod. The rods would cause a small drilled and tapped block to move closer to the top of the rod. The spring is attached to the bottom of the small block and to the side of the flange mounted bearings, so when the block moves up the springs are stretched. In this way, a vertical load is applied to the specimen. A diagram of this procedure can be seen in figure: 3-9.

Disadvantages of Design 1:

- A taller tower, which would likely be more susceptible to fatigue, would be required for operation.
- Springs may fatigue over course of testing.
- Load would be measured by spring displacement which would be prone to user error.
- Several moving parts would add to complexity.

Advantages of Design 1:

- Light weight.
- Springs are known to be used in existing products similar to ours.
- Load can be varied in extremely small increments.

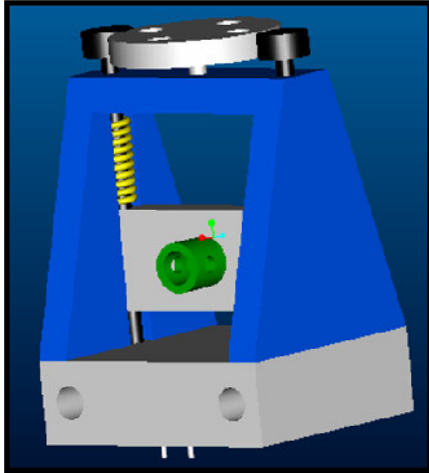

Figure 3-8

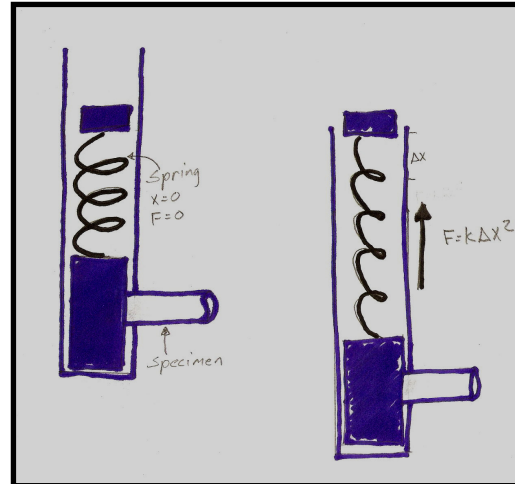

Figure 3-9

Design 2

This design utilizes weights to apply a downward force on the specimen. A container located above specimen can be loaded with weights. The load is free to move downward. Force is applied via a single ball bearing in contact with the specimen.

Disadvantages of Design 2:

- Direct contact with specimen could deform specimen surface.
- Loading increments are limited by the weights available.
- Loose weights would require extra dampening to prevent vibration.
- Additional loading increases overall mass of platform, which is moved for tensile loading.

Advantages of Design 2:

- Easily determinable load application.
- Simple design.

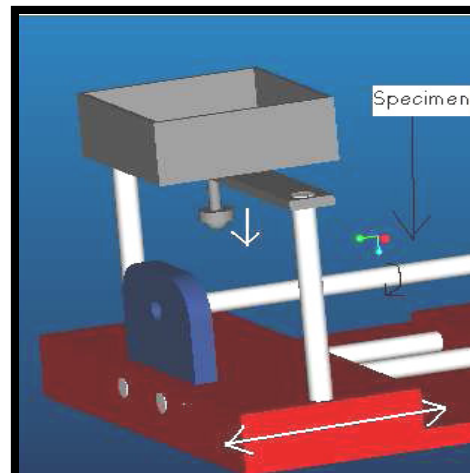

Figure: 3-10

Design 3

This design utilizes a screw driven system to lift the flange mounted bearings which house the end of the specimen. The screw applies a downward load on a force transducer. The end of the specimen experiences an equal load in the opposite direction. Figure: 3-12 diagrams this process.

Disadvantages of Design 3:

- Screw could loosen during operation thus decreasing the load.
- Tight tolerances required for smooth operation.

Advantages of Design 3:

- Simple design.
- Light weight.
- Load cell allows for data acquisition as well as accurate determination of load.
- Load can be varied in extremely small increments.

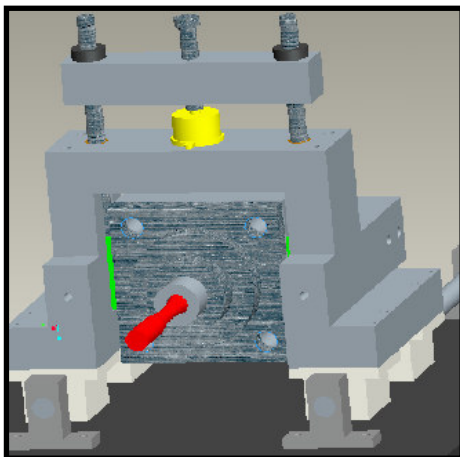

Figure 3-11

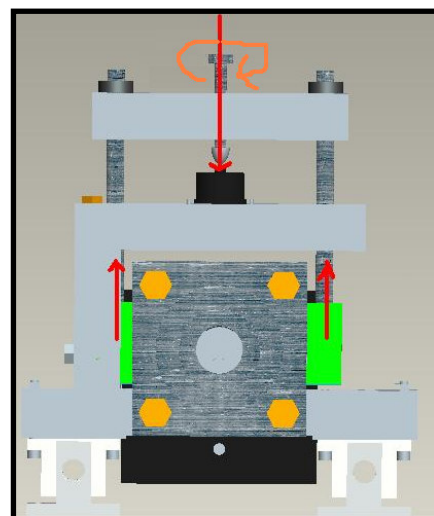

Figure 3-12

Vertical Load Assembly Selection Decision Matrix

All three vertical load assembly concepts were evaluated on mass, reliability, practicality and expected performance.

Mass (.25): Mass was a defining factor for the reason that the vertical load assembly would need to be translated.

Reliability (.25): Reliability was based on the projected life of each system. Moving parts or parts that are susceptible to fatigue were cause for concern when rating this particular category. Reliability was considered crucial due to the duration of the tests that are to be performed.

Practicality (.15): Practicality was based

Performance (.35): Variability of each system was important in the rating of each assemblies performance. The ability to vary applied loads is considered important for precise testing.

Decision:

After compiling scores in the decision matrix (Figure 3-13) design 3 was the clear choice. The overall simplicity of design 3 along with the ability to precisely vary load were key in this selection.

Condition	Mass	Reliability	Practicality	Performance	Total
Weight	0.25	0.25	0.15	0.35	1
Design					
1	5	3	3	4	3.85
2	1	4	2	2	2.25
3	5	4	5	4	4.4

Figure 3-13

Tensile Fatigue Selection

Several concepts were reviewed for the tensile loading mechanism. Listed below are the concepts, a brief explanation, and the reason for pursuing or not pursuing. All concepts reviewed were taken from ASTM E 466. Many concepts were determined not feasible early in analysis and thus no design matrix was created.

Hydraulic System: A single or dual action piston which moves the cross head up or down.

Reason for not pursuing:

- Lower than desired cycle frequency capabilities for cost.
- High maintenance.

Rotating Mass: An eccentrically rotated mass is used to produce a tensile load on a specimen.

Reason for not pursuing:

- Extremely complex design.
- Limited loading capabilities.
- Applying bending load would have been extremely difficult.

Pneumatic solenoids: Utilizes compressed air to produce forces.

Reason for not pursuing:

- Noise (machine would have been operated in school machine shop) would have been a nuisance.
- Would not be able to control the shape of the load curve.

Magnetic solenoids: Use an electromagnetically inductive coil to move a metal slug in and out of the center of the coil.

Reason for not pursuing:

- Solenoids available at desired load capabilities were out of price range.
- Push rods in solenoids within price range had small diameter, leading to concerns about durability.

The following two methods were looked at more closely.

Mechanical System: Utilizes a motor driven system of lever arms to displace end of specimen.

Reasons for Pursuing:

- Desired frequencies can be achieved.
- Specimen can be forced back to original position. No need to wait for system to relax back to original position on its own.
- Sinusoidal load curve can be produced for both tensile-only and fully reversed cycling.

Reason for not pursuing:

- Tight tolerances would make fabrication difficult.
- Load would be calculated via displacement.

Electromagnets: Can push off against another magnet or attract a material with a high magnetic permeability.

Reasons for pursuing:

- With appropriate electronics and configurations, could produce a wide range of load curves.
- Off-the-shelf product
- No moving parts.

Reasons for not pursuing:

- Relatively low power within price range.
- Must guard against overheating (especially for a long duration test).
- Force decreases rapidly with distance. Therefore precise positioning is more important.

Decision:

A mechanical system (Figure 3-14) was initially pursued until it was determined that fabrication difficulties would not be overcome. Electromagnets were then chosen, along with an on/off power cycler that produces a square wave for the load curve.

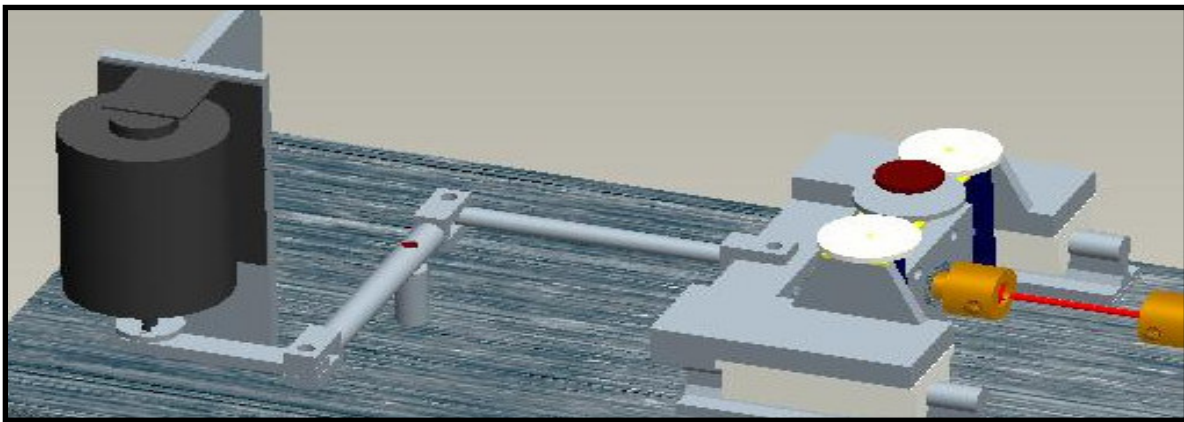

Figure 3-14

Design Modifications

Motor- The original motor selection for the rotating bending cycle had 1/2 horsepower and produced a maximum of 3600 rpm. The electric motor was single phase and operated off of a 120V power source. Once it was determined that the maximum cycle frequency for tensile loading would not exceed 30 Hz a new motor was selected. The final motor selection has 1/3 horsepower and operates at up to 1800 rpm. This corresponds to the 30 Hz produced in tensile loading.

Left Grip- The initial left grip (Figure: 3-15) was designed to be a separate component from the main shaft and would have been attached to the main shaft using a rigid shaft coupling. The

design was altered to incorporate the grip into the main shaft (Figure: 3-16) itself, thus eliminating the need for a separate left grip, the rigid coupling, and shortening the overall length of the fatigue tester.

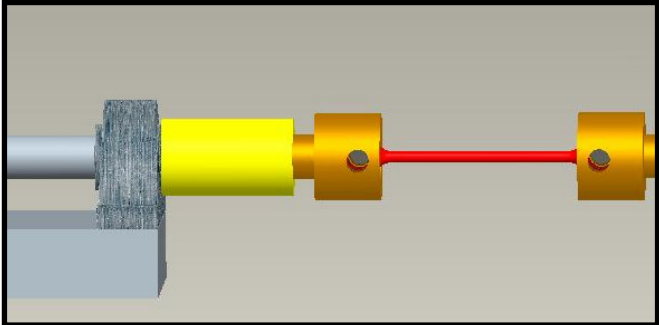

Figure 3-15

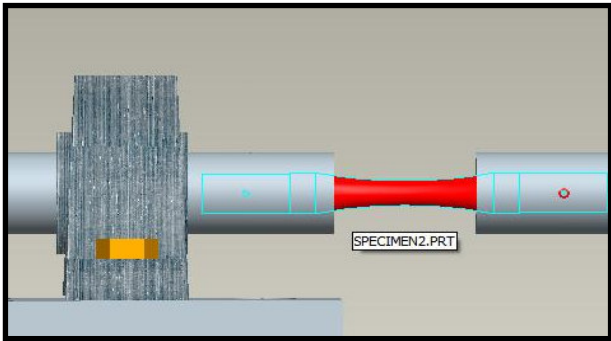

Figure 3-16

Electromagnet Tensile Loading Arrangement- Prior to initial assembly of the machine, the design called for two electromagnets (Figure 3-17) located on either side of the platform.

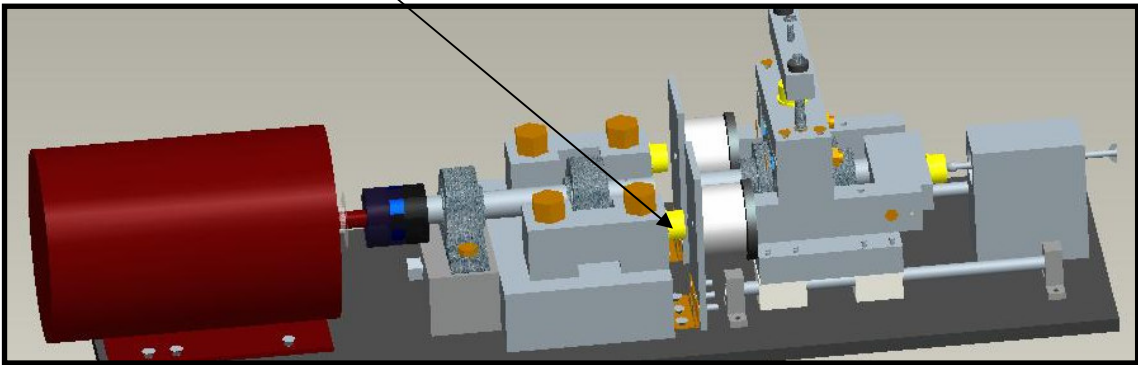

Figure 3-17

These electromagnets were intended to oppose two permanent magnets mounted on the platform and provide a repulsive, or pushing force. Based on an experiment with permanent magnets, it

was expected that each electromagnet/permanent magnet pair would provide roughly 17 lbf, for a total of approximately 34 lbf of tensile loading.

When testing this arrangement, it was discovered that the tensile loading delivered was negligible. It is speculated that this is due to a difference in magnetic field structure between the electromagnets and the permanent ceramic magnets. The design was changed to utilize the electromagnet's holding force on a 1/2 inch steel plate (Figure 3-19) in black. The configuration was changed to placing an electromagnet behind the platform with a steel plate mounted on the back of the platform (Figure 3-18). In this position the electromagnet was able to attract the steel plate, thus applying a tensile load to the specimen.

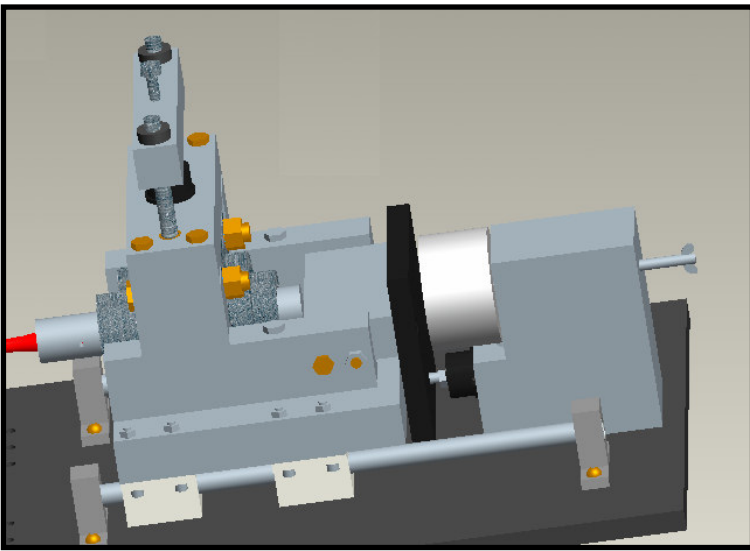

Figure 3-18

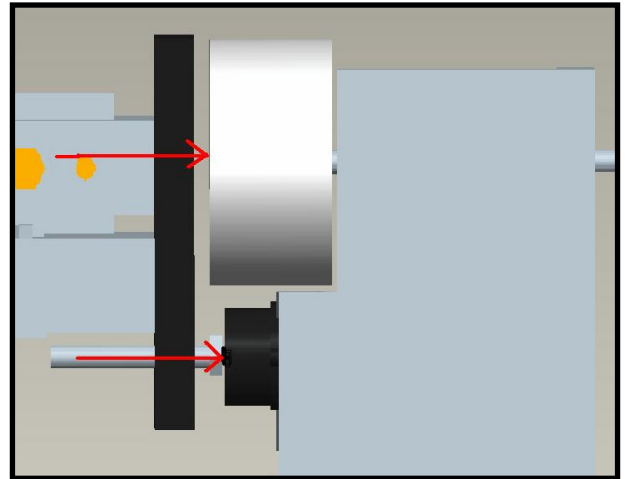

Figure 3-19

Final Design

Note: Engineering drawings and part specifications are located in Appendix C.

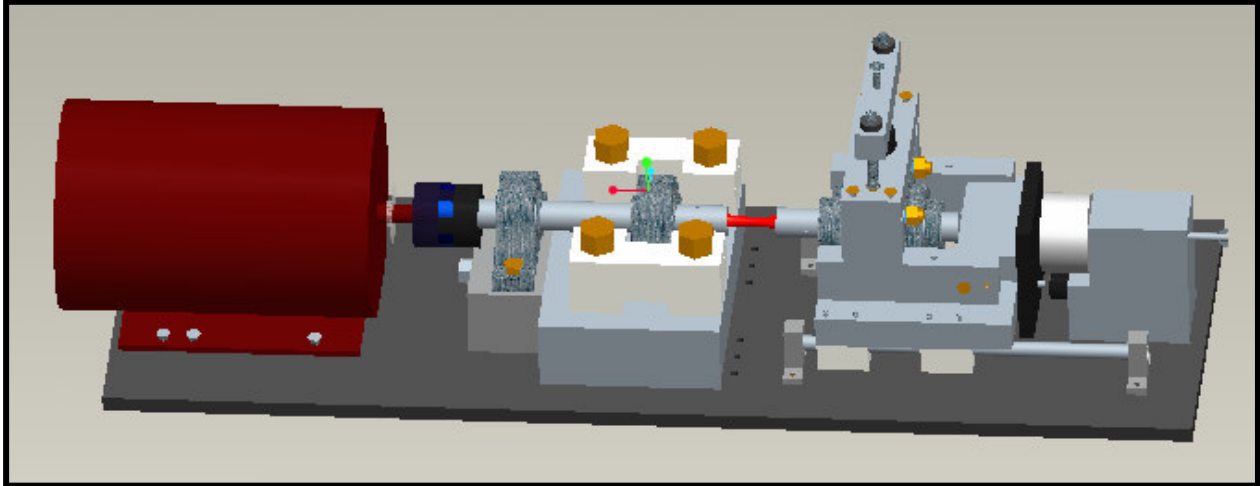

Figure 3-20

In the current design (Figure 3-20), the tester can be configured to act as a tensile fatigue tester, a rotating-bending fatigue tester, or a combination of the two. The horizontally mounted motor will provide the rotation (at up to 30 cycles/second) for the rotating-bending mode of operation. Looking from the side and moving left-to-right in Figure 3-20, a motor is mounted to the base. The shaft of the motor is connected to the 1" main rotating shaft by means of a spider coupling. A spider coupling was chosen in place of a rigid coupling in order to allow for minor misalignment between the main shaft and the motor. The main rotating shaft passes through a set of pillow mounted ball bearings to ensure that no significant bending of the shaft is transmitted to the coupling between the main shaft and the motor.

Two flange mounted bearings are placed on the outside of an aluminum block. The aluminum block has a pin connected on each side which in turn fits into a guide block that is fitted into the vertical track. In this way, the bearings can both pivot and translate vertically if desired. The vertical bending load is applied by tightening a screw down onto an aluminum block which is attached to the top of the vertical assembly. The screw is set in another aluminum block above the top of the vertical assembly which has two guide rods on each side of the screw that is connected to the top of the two guide blocks. When the screw is tightened the guide blocks will move up and the force applied to the system will be measured with a force transducer that is placed under the screw applying the force.

The vertical assembly has a half inch steel plate mounted to the rear. The vertical plate is pulled on by a magnetic force produced by an electromagnet mounted at the rear of the assembly. This electromagnet is adjustable via a screw which runs through the rear support and mounts to the electromagnet. Below the electromagnet on the rear support is a load cell which is depressed by an adjustable bolt on the steel plate.

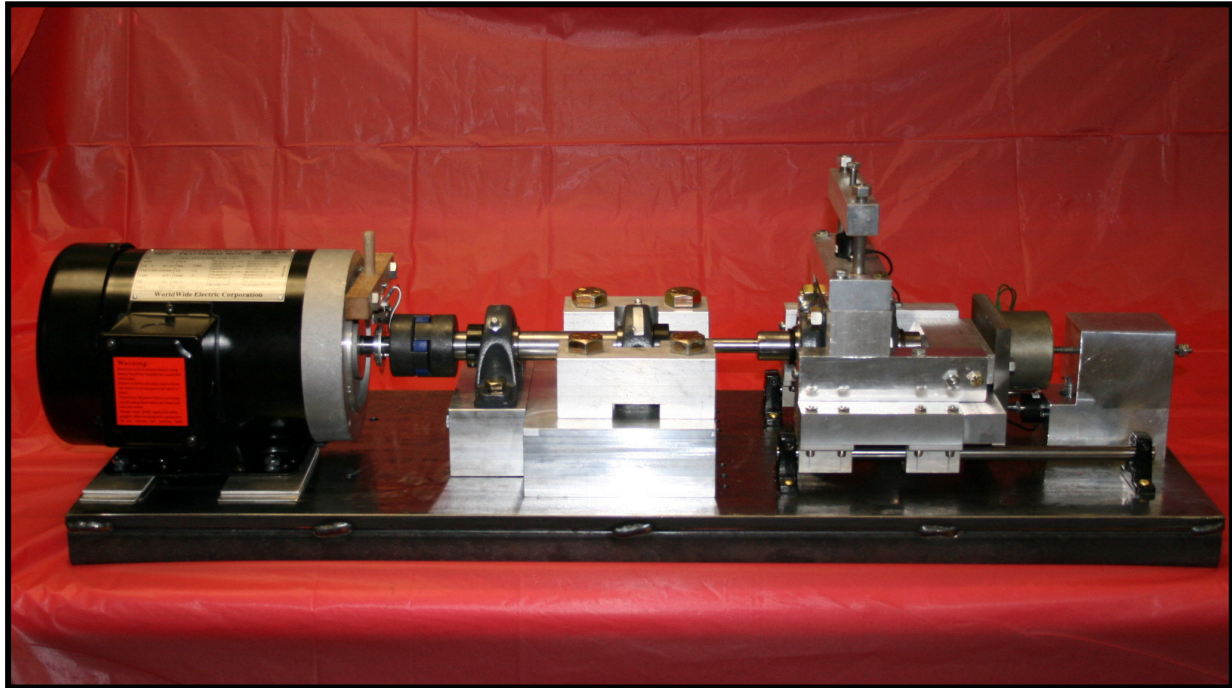
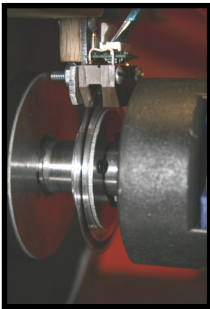

Figure 3-21: Final Assembled Machine

Component Breakdown



Motor: The motor provides the rotation for the rotating bending portion of the operation. Spacers have been machined in order to allow vertical adjustment of the motor height for better alignment with the main shaft. The motor base provides slotted holes for mounting which allow side to side movement for better alignment



Optical Encoder: The optical rotary encoder is mounted to the motor shaft and in conjunction with Labview counts shaft rotations.

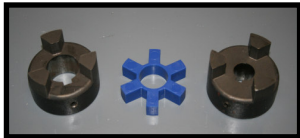

Spider Coupling: The spider coupling, which consists of three parts, allows for minor misalignment between the motor shaft and the main shaft. The spider coupling also allows for the distance between the motor shaft and the main shaft to be varied.

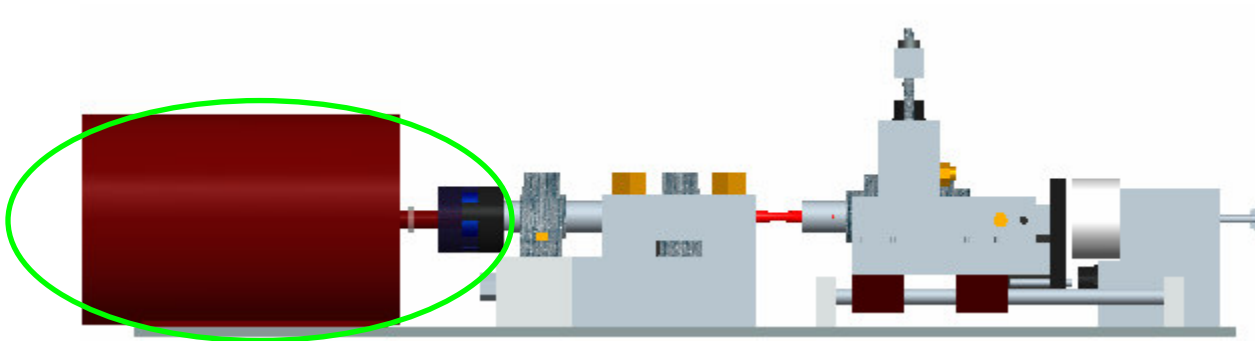



Main Shaft: The main shaft transmits rotation from the motor to the specimen. One end of the shaft (the right end when viewing the figure?) is tapered which allows it to act as a grip for the specimen.



Pillow Block Bearings (2): The main shaft runs through the two pillow block bearings. The pillow block bearings utilize eccentric locking shaft collars to prevent linear translation of the main shaft.



Aluminum Spacers: The aluminum spacers serve as mounts for the pillow block bearings as well as the mounted supports. The aluminum spacers place the pillow block bearings at a height that is similar to that of the motor.

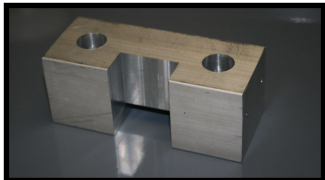

Mounted Supports (2): The mounted supports provide added support for the pillow block bearings. The mounted supports are for safety purposes.

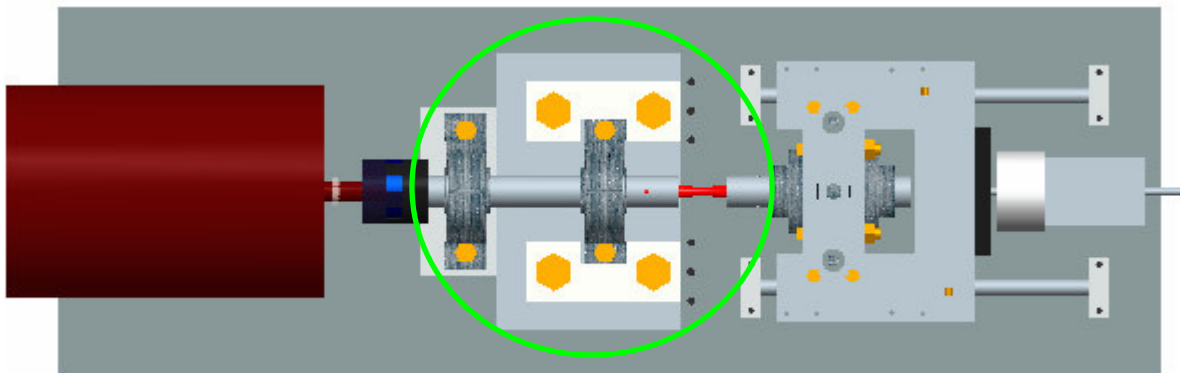



Right Grip: The right grip secures the end of the specimen not held by the main shaft. The right grip runs through the flange mounted bearings as well as the pivot plate.



Flange Mounted Bearings: The flange mounted bearings allow the specimen free rotation. The flange mounted bearing are also connected the vertical load assembly. Eccentric locking collars, like the ones on the pillow block bearings,



Linear Tracks and Mounts (2): The linear tracks and mounts support the mass of the vertical load platform and provide a mounting for the linear bearings.



Linear Bearing (4): The linear bearings are mounted to the bottom of the vertical load assembly.

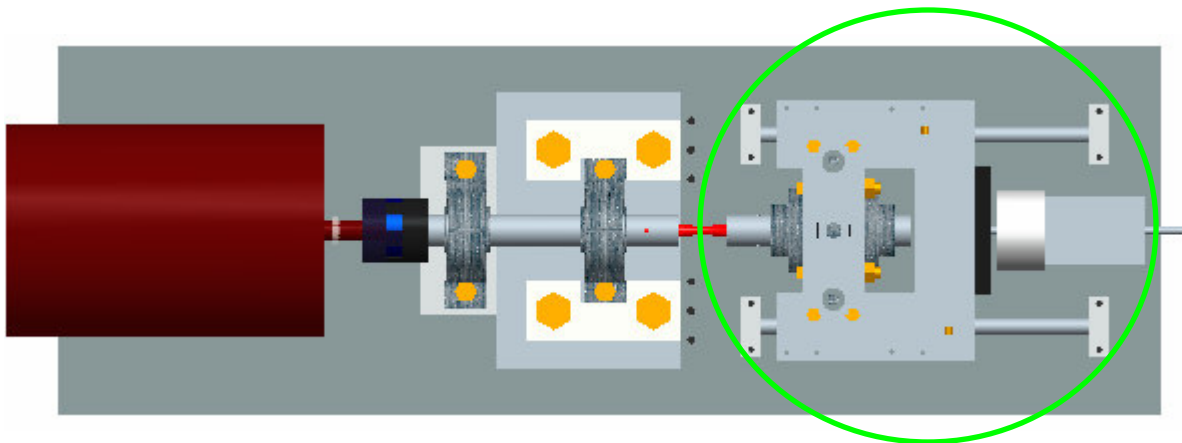

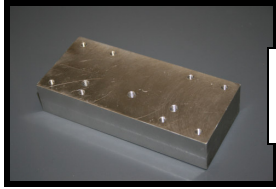

Linear Bearing Mount: Serves as a mount for the linear bearings as well as the vertical track guide.

Vertical Track: Provides slot for vertical track guide.

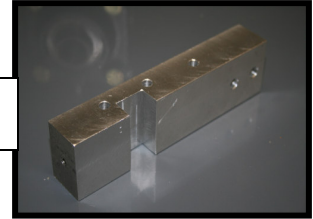

Vertical support: Extends slot from vertical track guide and connects vertical track and top load cell mount

Vertical Track Guide: Allows flange mounts bearing vertical movement.

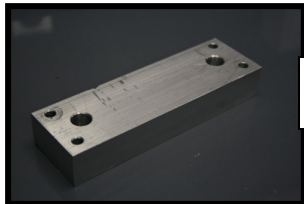
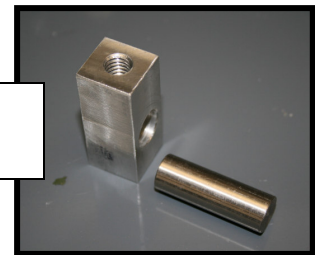

Top Load Cell Mount: Provides mount for load cell.

Top Bar: Provides mounting for screw that applies bending load.

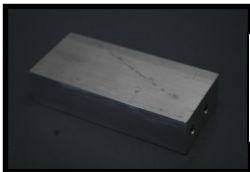

U-Connection: Connects and supports vertical tracks. Also serves as a mount for the steel plate.

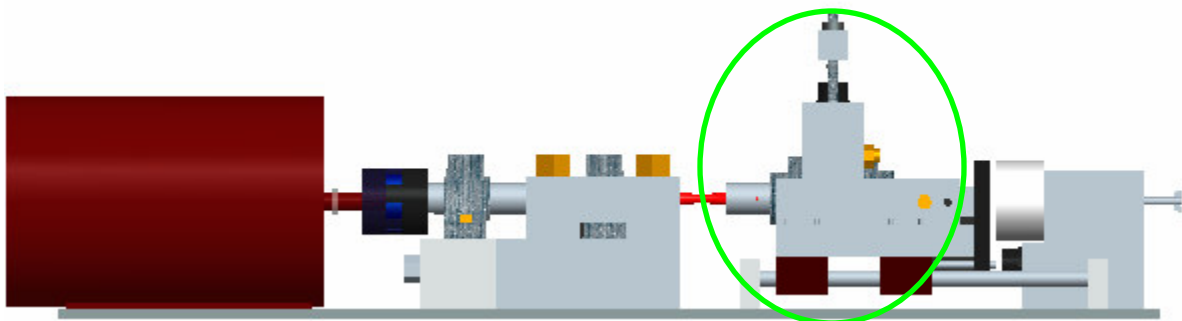

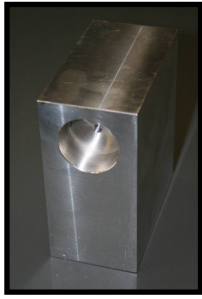

Electromagnet Support: Provides mount for electromagnet and rear load cell

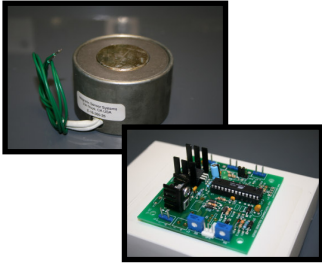

Electromagnet and On-Off Power Cycler: Mounts to electromagnet support and provides tensile load.

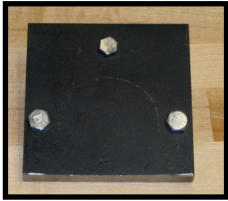

Steel Plate: Mounts to the rear of the vertical load assembly. Holds adjustable screw that applies load to rear load cell. Is attracted by electromagnet.



Base: The base provides a rigid support for all components of the machine to be mounted

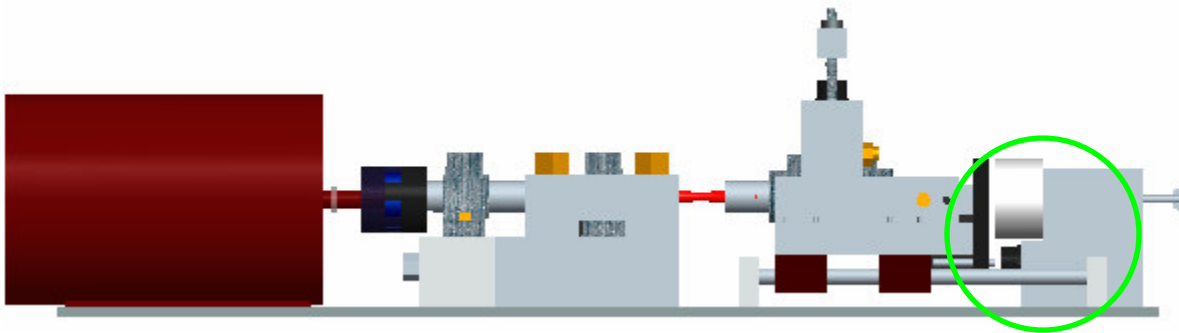

IV. Project Results

Project Summary

Three major tests were performed on the combination fatigue tester. The first of the three tests analyzed the vertical load portion of the tester. The second analyzed the tensile loading portion of the tester and the third analyzed the optical encoder's ability to collect cycle data. All test data was gathered utilizing a Lab View program written by Kevin Garvey, a graduate student at Florida State University, and load cells. It should be noted that the program was setup to test individual components. With this being said only one load cell could be tested at a time. If the fatigue tester was actually being used for testing a need for data from both load cells, simultaneously, would be necessary. A screenshot with critical testing features is displayed can be seen in Figure 4-1.

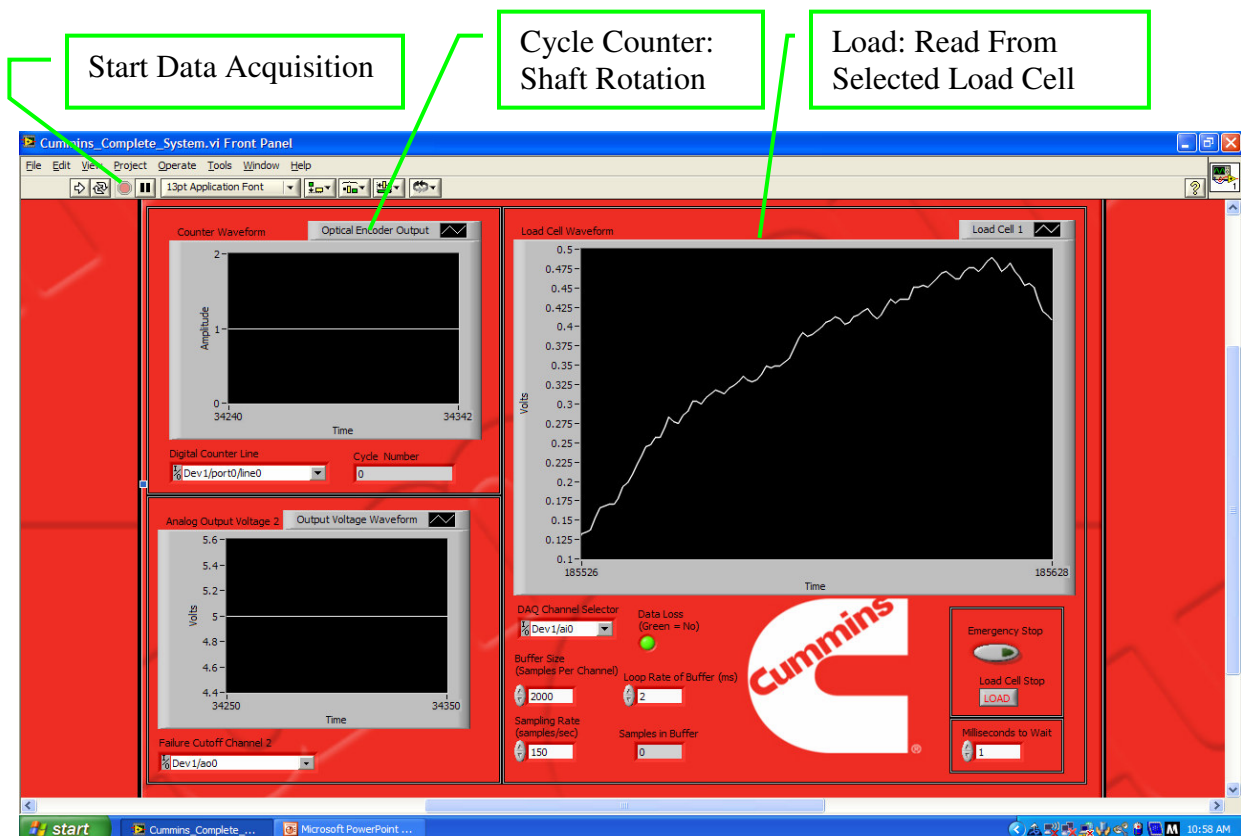

Figure 4-1

Tensile Load:

Figures 4-2 and 4-3 display the load cycle exhibited by the electromagnet used for applying tensile loading. One volt (y-axis) is equal to approximately 22 lbf. The timescale (x-axis) is centi-seconds. Thus the graph displays a load of approximately 1.54 lbf being applied at a rate of 4 Hz. This load was being applied with a 12 V power source driving the electromagnet. This demonstrates that the combination fatigue tester was successful at applying a cyclic load. It should be noted that a maximum of approximately 5 lbf was achieved with the 12 V power source.

Figure 4-3 displays a force of approximately 10 lbf being applied at a frequency of approximately 1 Hz.

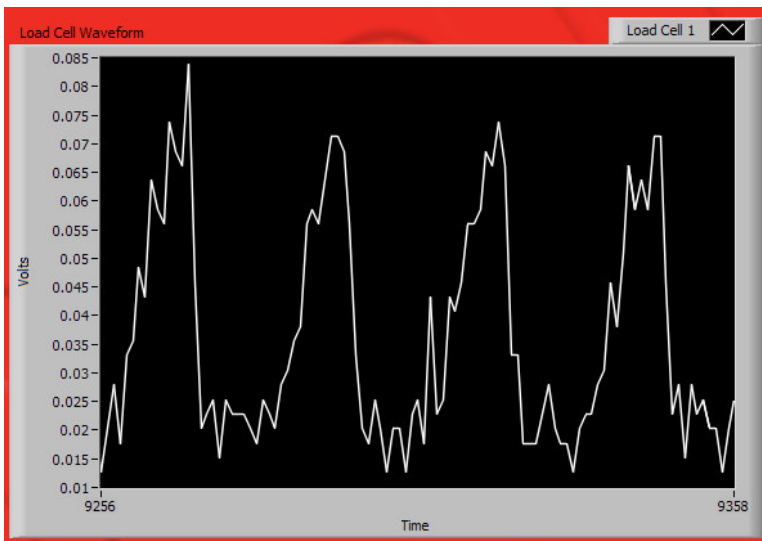

Figure 4-2

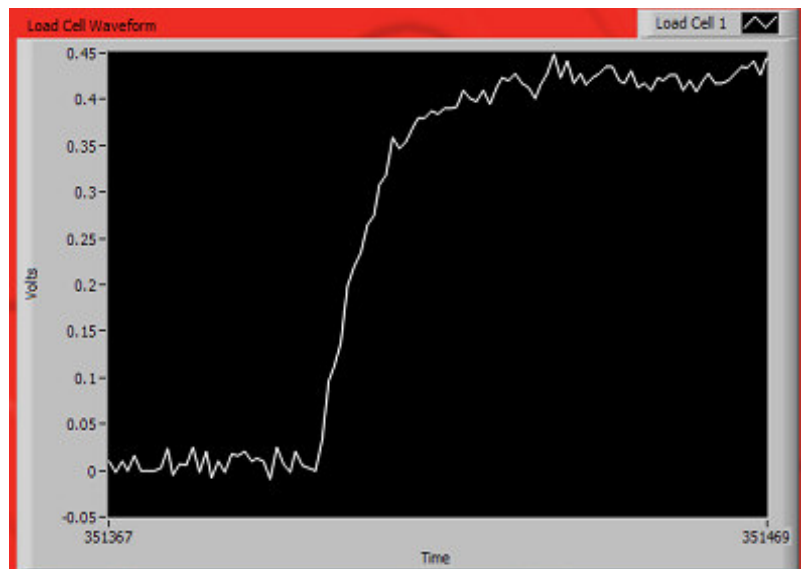

Figure 4-3

Vertical Load:

Figure 4-4 shows the constant load applied by the vertical load assembly. The display shows a force of approximately 7 lbf. The cause of the constant change in amplitude was not determined. One cause for concern was the fact that the voltage, and in turn load, steadily decreased. After roughly 4-5 minutes steady state was reached. This leads us to believe that there are unaccounted forces such as friction present. This is likely due to the components of the vertical load. For vertical load cyclic loading conditions are not necessary.

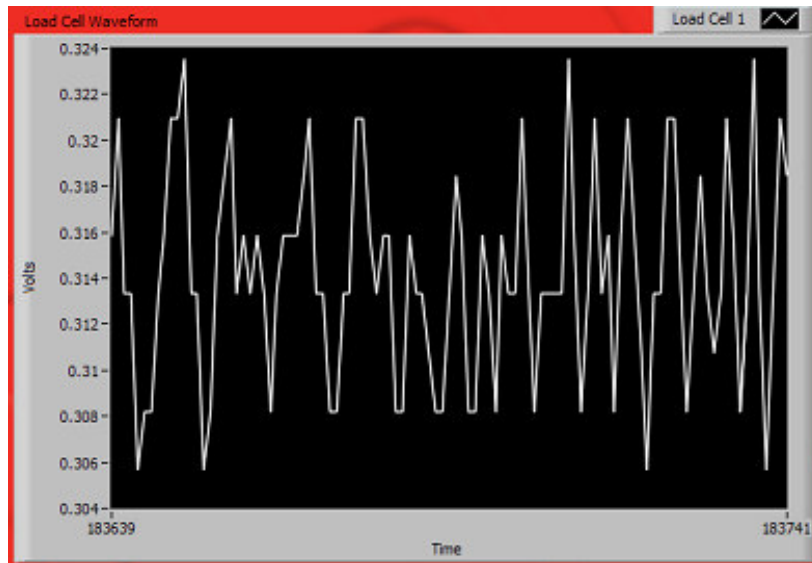

Figure 4-4

Optical Encoder:

Figure 4-5 displays the optical encoder output. Many issues were encountered when attempting to properly mount and aligning the optical encoder, which led to several tests. Eventually useful data was acquired.



Figure 4-5

Problems and Solutions

Problems:

1. The alignment of the main shaft with the right grip was off.
2. The alignment of the motor shaft and main shaft was off.
3. The alignment of the Optical Encoder Disk and the Optical Encoder Sensor was off.
4. Loading of the specimen was difficult due to lack of loading space.
5. Vertical guide tracks were uneven and produced too much friction with the slider blocks.
6. Vertical track rods threading was off with guide block threading.
7. Specimens threading was off with the left and right grip threading.
8. Lab View can only read one load cell at a time.

Solutions:

1. The screw used for the vertical load can be tightened to raise the right grip and loosened to lower the grip. Shaft alignment can be reached used this technique.
2. Metal spacers were placed under the motor to make the shafts align.
3. An adjustable holder for the optical encoder sensor was build. The holder can change adjust the location of the sensor over the optical encoder disk.

4. The steel plate base should be extended to add more room for the horizontal track to move.
5. The slider blocks and the vertical track guides were sanded down on a belt sander until they were able to slide smoothly together.
6. The only way to fix this problem would to get the vertical track rods threaded on a more precise machine.
7. The only way to fix this problem would to get the specimens threaded on a more precise machine.
8. Two computers with Lab View will have to be open to display the data from both load cells.

Recommendations

The final design of the Cummins 2 combination fatigue tester proved, on a small scale, to have many effective design components. It should first be mentioned that many components were designed with the constraints of limited machining and limited budget. It should also be noted that there are several proven ways to accomplish several of our goals, i.e. tensile and bending loading, many of which were disregarded due to the aforementioned constraints. With all of this said, if the design mentioned throughout this report were to be manufactured for industrial use, several issues would need to be addressed. Listed below are recommendations for these issues.

1. Fabrication of critical parts, i.e. shafts and specimens, should be machined with high tolerances in order to ensure alignment.
2. Grip design, tapped for use with a threaded specimen, may be prone to misalignment issues. Exploration of others grip designs is recommended.

3. For tensile fatigue testing a load cell should be placed in-line with the specimen.
4. Programming to control the distance of the magnet from the steel plate should be implemented in order to maintain constant tensile loading force.
5. Replace the steel plate used for magnet attraction with a metal that has a higher permeability such as Mu-metal.
6. Vibration analysis should be performed in order to determine necessary dampening controls.
7. All data acquiring instruments, i.e. load cells, should have low error.
8. Methods for cycle count need to be addressed.
9. A more powerful magnet that can apply minimal load of 1500 lbf at a distance of .005 in. is recommended.
10. Utilize a function generator to control electromagnetic force as opposed to on-off power cycler.
11. Implementation of a safety cover should be fabricated to protect operator during testing.
12. A physical cutoff switch should be added to the tester.

Appendix A

Bill Of Goods					
Part #	Part Name	Quantity	Part #	Part Name	Quantity
1	Base	1	35	Electromagnet	1
2	Large Spacer	1	36	3/8-20 Nut	2
3	Small Spacer	1	37	1/4-20x2 bolt	2
4	Mounted Support (right)	1	38	1/4-20x4.5 bolt	4
5	Mounted Support (left)	1	39	1/4-20x6.5 bolt	2
6	Pivot Plate	1	40	1/4-28x1.5 bolt	1
7	Pivot Pin	2	41	1/4-28x2 bolt	1
8	Vertical Track Guide	2	42	1/4-20x5 w/ 1 in 1/4-28	1
9	Vertical Guide Rod	2	43	1/4-20 acorn nut	1
10	Rear Support	1	44	1/4-28 acorn nut	1
11	Vertical Track	2	45	1/4-20 nut	2
12	Linear Bearing Mount	2	46	10-32 machine screw	8
13	Platform Connector	1	47	10-32x1 socket cap screw	8
14	Vertical Support	2	48	10-32x1.5 socket cap screw	8
15	Vertical Load Cell Mount	1	49	10-32 nut	8
16	Top Bar	1	50	5/16 bolt	4
17	Main Shaft	1	51	5/16 nut	4
18	Right Grip	1	52	7/16x2.5 bolt	4
19	Steel Plate	1	53	7/16x4 bolt	4
20	Specimen Blank	1	54	7/16 nut	8
21	Rear Brace	N/A	55	3/4-16x6	4
22	Specimen	2	56	3/4-16 Nut	4
23	Motor	1	57	1/2-13x2.5 bolt	1
24	Spider Hub (5/8 in. Dia.)	1	58	1 - 8x3 Bolt	2
25	Spider	1	59	4-40 screw	2
26	Spider Hub (1 in. Dia.)	1	60	6-32 Screw	2
27	Pillow Block Mounted Bearings	2	61	Motor Speed Controller	1
28	Flange Mounted Bearings	2	62	Input Kit for motor controller	1
29	Linear Bearings	4	63	Motor Starter	1
30	Linear Shaft	2	64	On/Off Power Cycler	1
31	Linear Shaft Mount	4	65	12VDC Power Supply	1
32	Rotary Encoder (Disk)	1	66	3/8-20 x1 bolt	2
33	Rotary Encoder (Sensor)	1	67	bushing	2
34	Load Cell	2			

Appendix B

Cost Analysis

Description	Cost \$	Company	Part Number	Quantity	Total \$
Pillow block bearings	68.71	Miller Bearings	TOR RAK 1	2	137.42
4 bolt flange bearings	68.71	Miller Bearings	TOR RCJ 1	2	137.42
					0
1"x4"x27" 6061 aluminum	58.82	Metal Fabrication	1"x4" Alum. Flat	1	58.82
1/2"x12"x36" Steel Flat	61.56	Metal Fabrication	1/2"x12" Steel Flat	1	61.56
Aluminum for pillow block spacer	48.75	Metal Fabrication		1	48.75
aluminum for small spacer	13.5			1	13.5
aluminum for load cell mounts	35	Metal Fabrication		1	35
aluminum for additional parts	15.74	Metal Fabrication		1	15.74
					0
Spider coupling	7.65	Mcmaster	2410K13	1	7.65
Coupling Hub with 1" bore	5.98	Mcmaster	6408K14	1	5.98
Coupling Hub with 5/8" bore	5.98	Mcmaster	6408K15	1	5.98
stainless steel shaft 1"x12"	19.5	Mcmaster	89095K232	2	39
Steel rod (1/2"x12")	13.23	Mcmaster	88915K221	1	13.23
Bushings	0.97	Mcmaster	6391K178	2	1.94
					0
					0
60 case Linear Race Support	17.16	Thomson Industries	TSB-8	1	17.16
Solid Steel 60 case Quick	3.55	Thomson Industries	TQS1/2L-12	1	3.55
Solid Steel 60 case Quick	3.39	Thomson Industries	TQS3/8L-12	1	3.39
linear bearings	47	Thomson Industries	TSPB-8	4	188
					0
Rotary optical encoder module	27	Encoder Technology		1	27
Rotary optical encoder disk	25	Encoder Technology		1	25
					0
					0
Electric motor	90.64	Fremont Industrial Supply	AT13-18-56CB	1	90.64
					0
					0
Load Cell	55	Digikey Corporation	MSP6951-ND	2	110
					0
					0
Cast Iron Fatigue Specimen	11	Laboratory Devices Company	CFR20	5	55
					0
					0
plug in adapter power supply	32.62	Fouraker Electronics, Inc.	12VDC 4.1A	1	32.62

on-off power cyler	126.18	<i>Electromechanics Online</i>	ELSOOPC	1	126.18
electromagnets	92.6	<i>Electromechanics Online</i>	ELMATU067040	1	92.6
shaft mount	27.02	<i>Mcmaster</i>	6068K23	4	108.08
steel screw (10 pack)	6.04	<i>Mcmaster</i>	91257A560	1	6.04
steel screw (5 pack)	4.98	<i>Mcmaster</i>	91257A706	1	4.98
steel screw (10 pack)	6.88	<i>Mcmaster</i>	91257A702	1	6.88
steel screw	3.31	<i>Mcmaster</i>	91257A882	4	13.24
steel screw	4.53	<i>Mcmaster</i>	91257A959	2	9.06
motor starter	134.04	<i>Mcmaster</i>	7603K57	1	134.04
motor speed control	265.99	<i>Mcmaster</i>	6488K21	1	265.99
input kit for motor	67.43	<i>Mcmaster</i>	6488K31	1	67.43
ceramic magnets (larger)	6.66	<i>Mcmaster</i>	5685K33		0
Assorted nuts, bolts, screws	60	<i>Home Depot, Lowes, Ace</i>		1	60
Assorted electrical supplies	20	<i>Radio Shack</i>		1	20
Total					2048.87

The budget for this project was \$2000. Approximately \$200 worth of parts were listed above that were actually donated. Therefore, the project came in under budget.

Appendix C

Circuit Diagram:

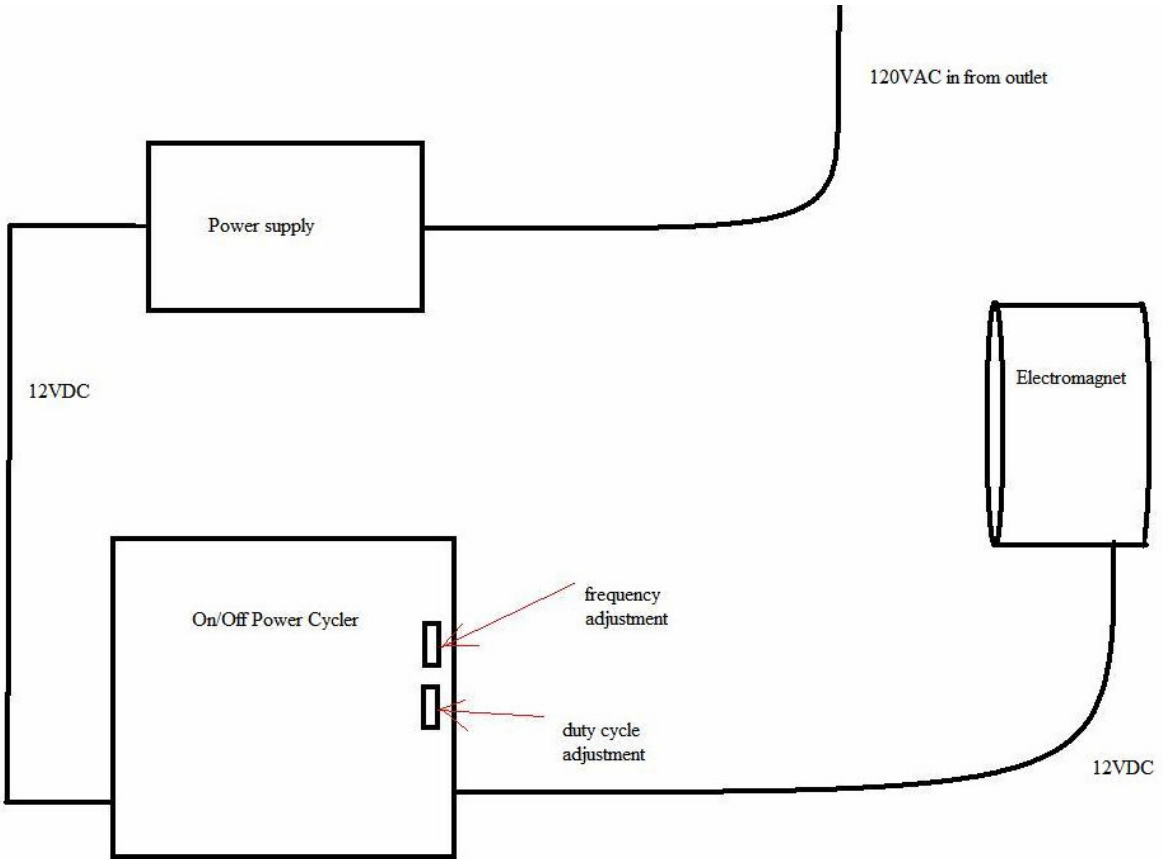

Appendix D

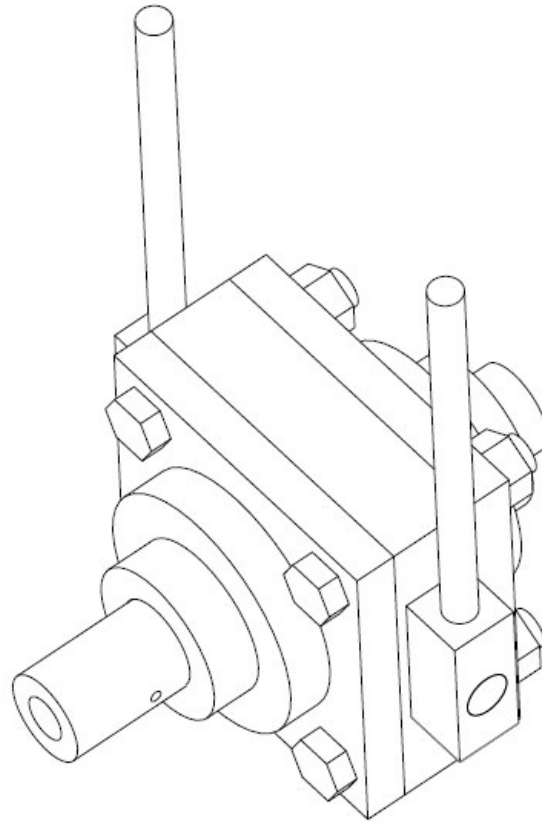

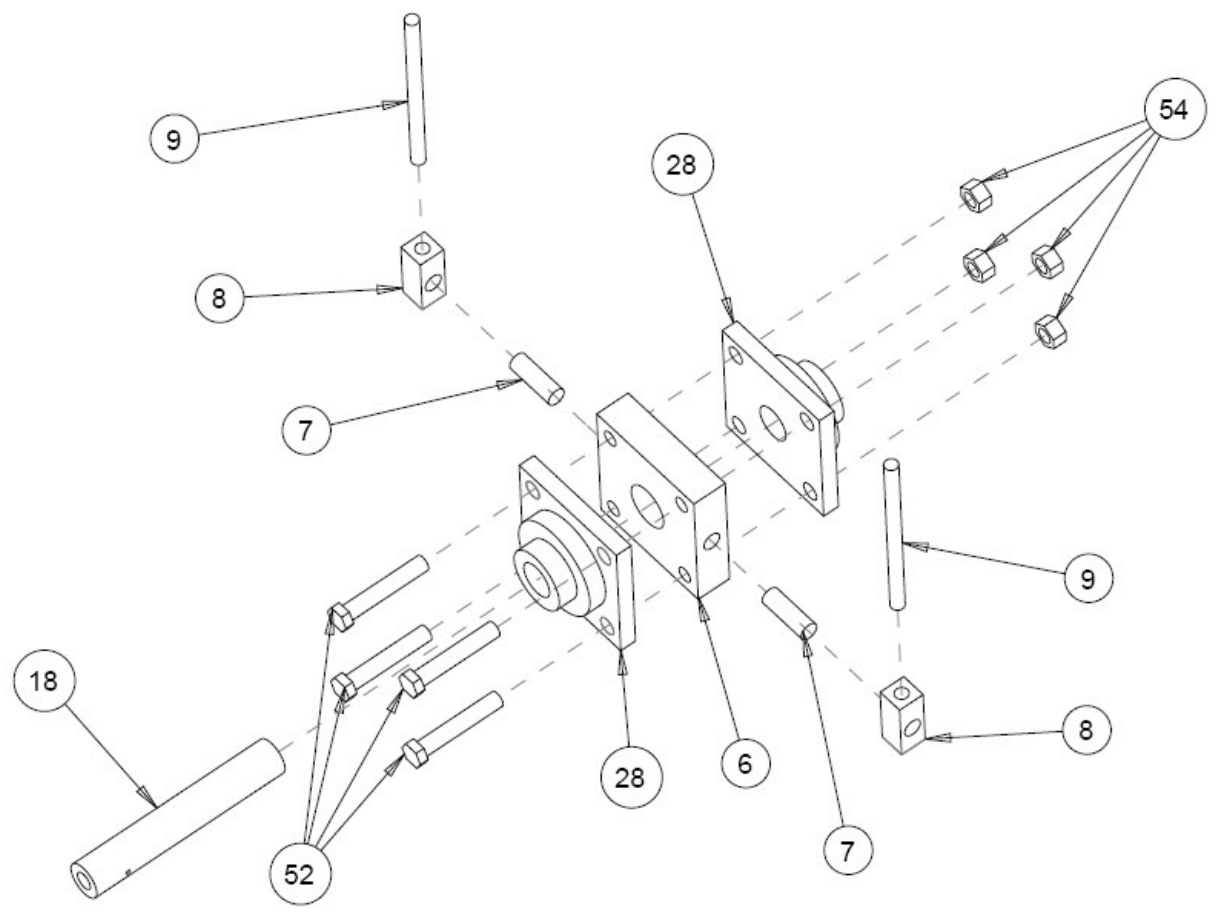

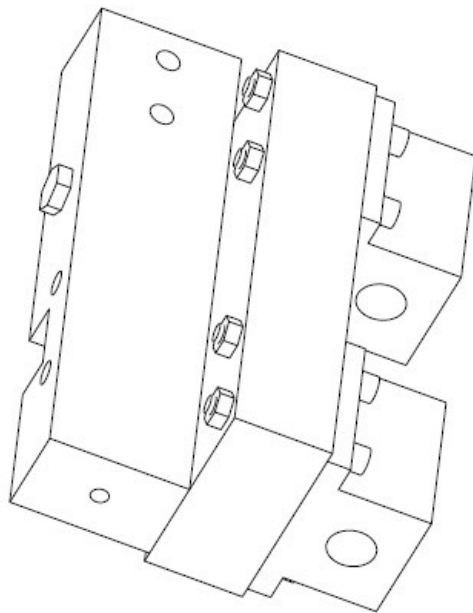

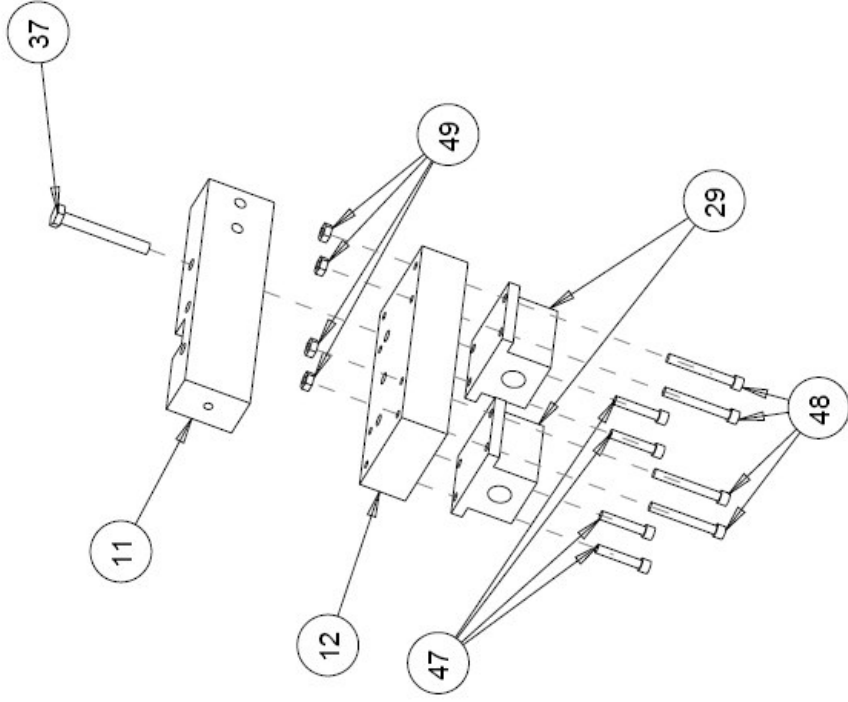

SCALE 0.350

Part Name: Subassembly B Exploded

Cummins 2: Team 11

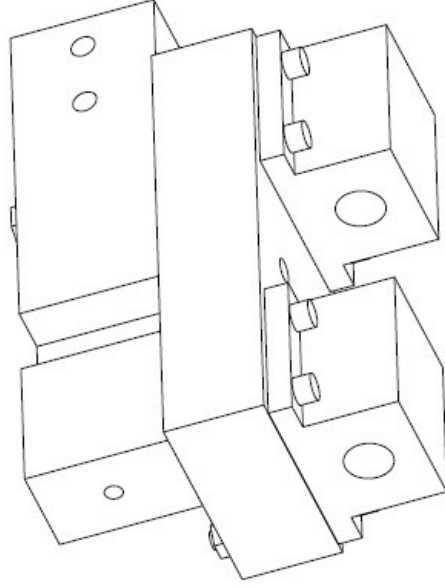

SCALE 0.750

Part Name: Subassembly C

Cummins 2: Team 11

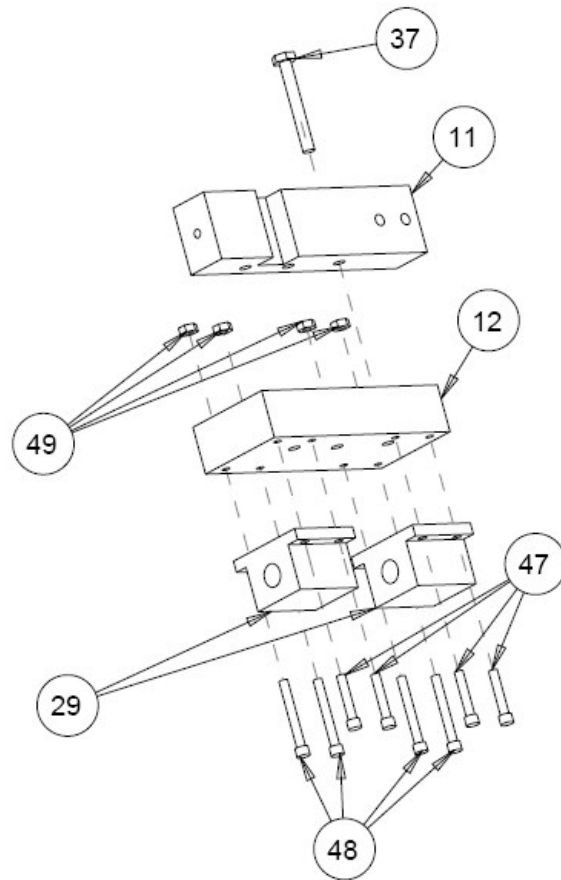

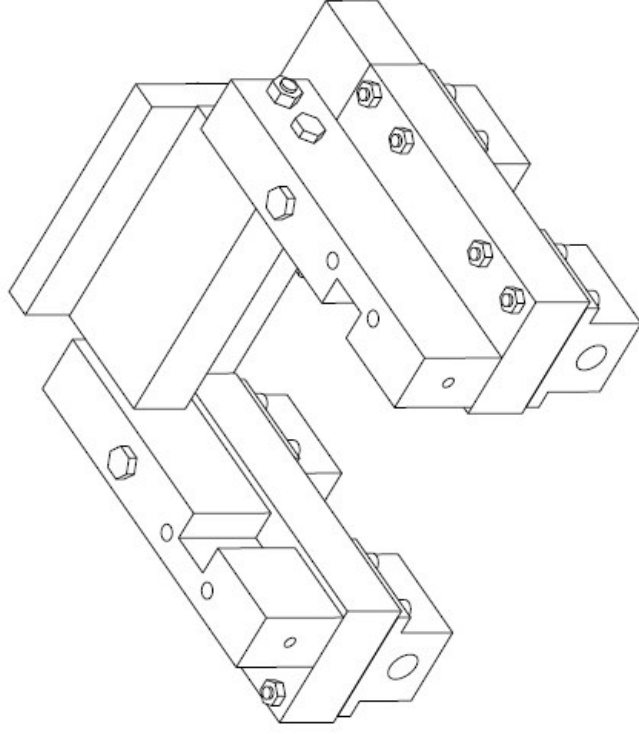

SCALE 0.500

Part Name: Subassembly D

Cummins 2: Team 11

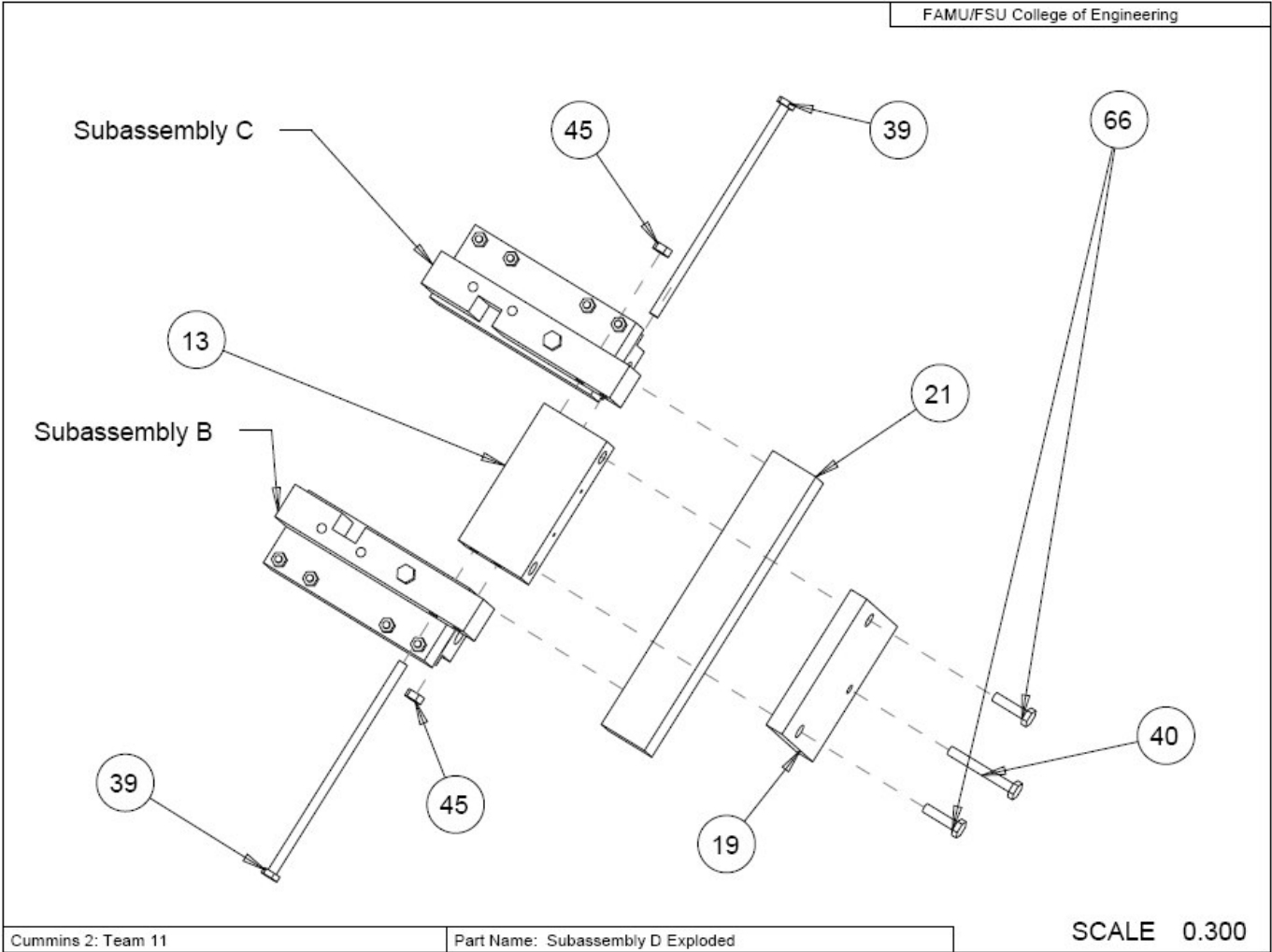

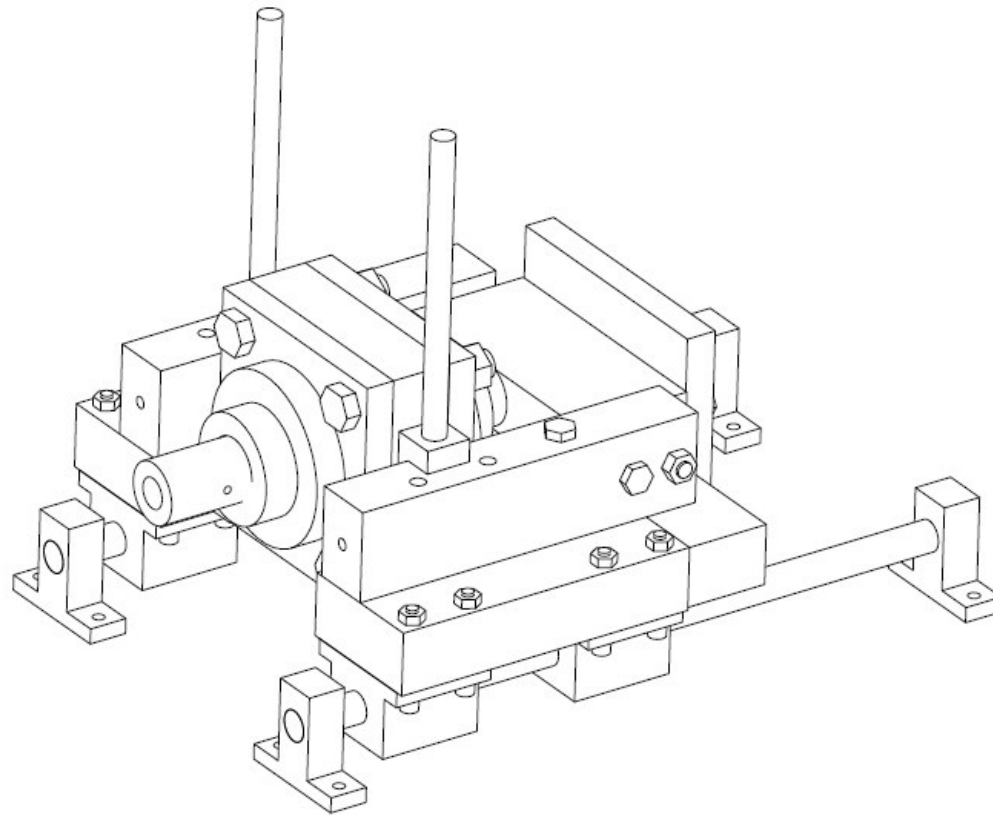

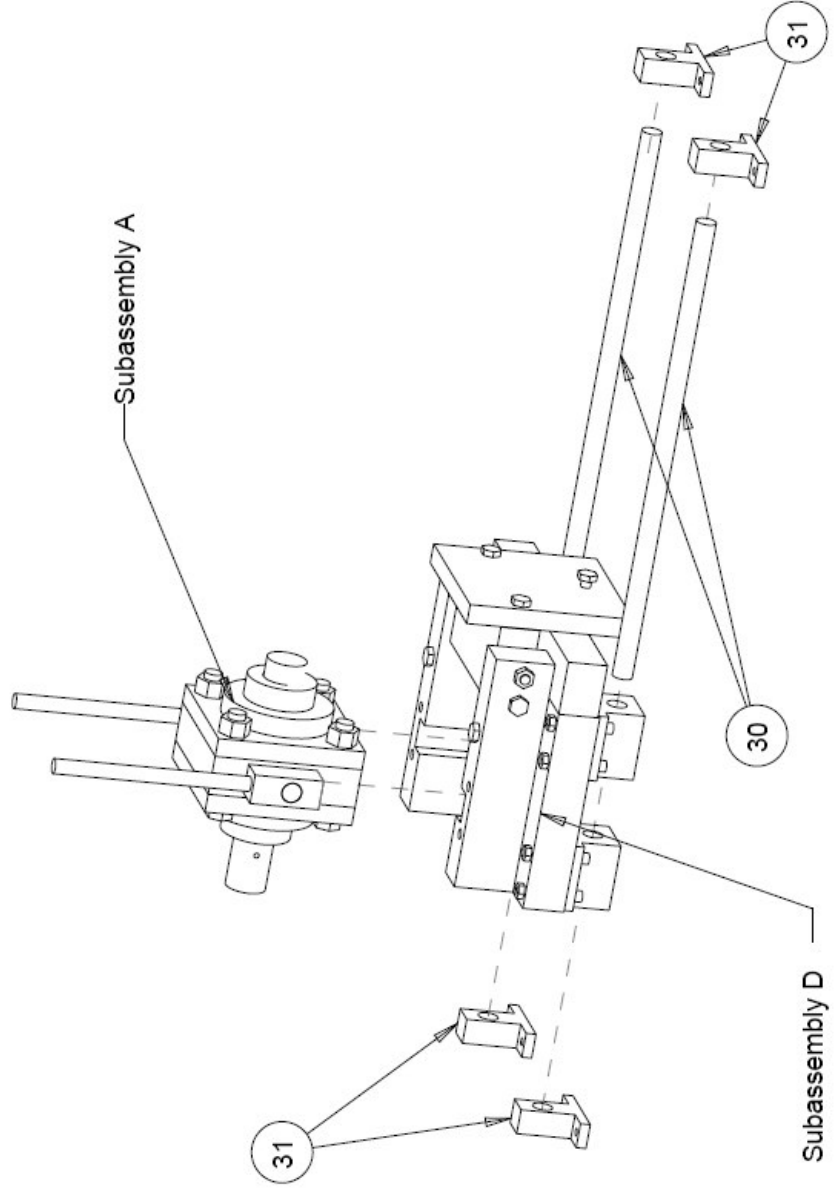

SCALE 0.300

Part Name: Subassembly E Exploded

Cummins 2: Team 11

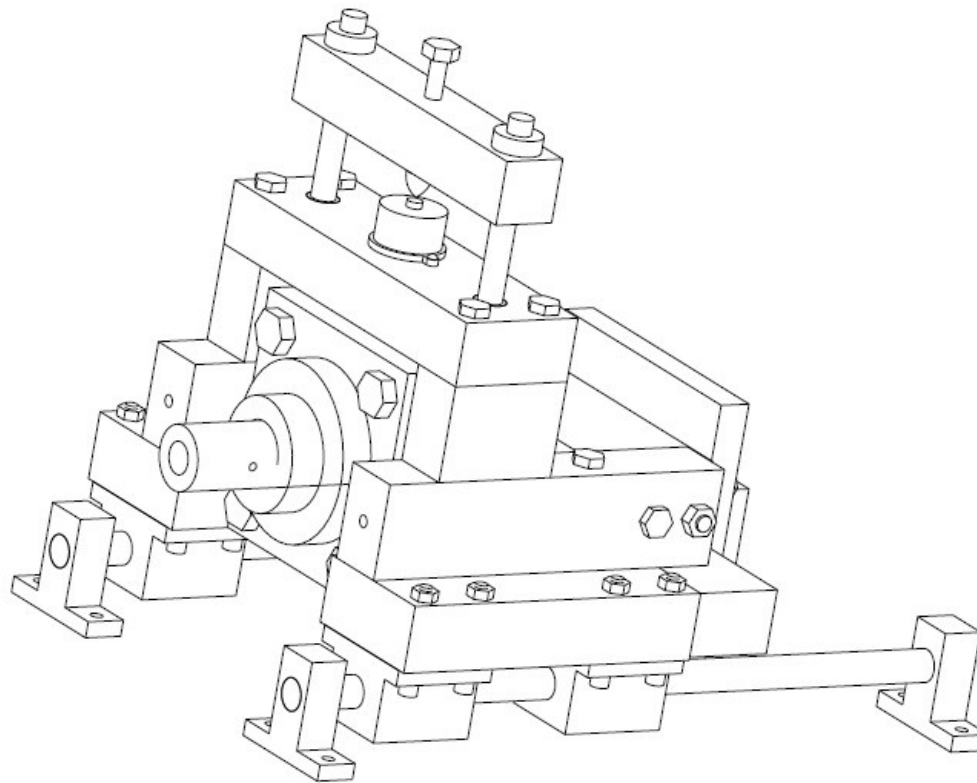

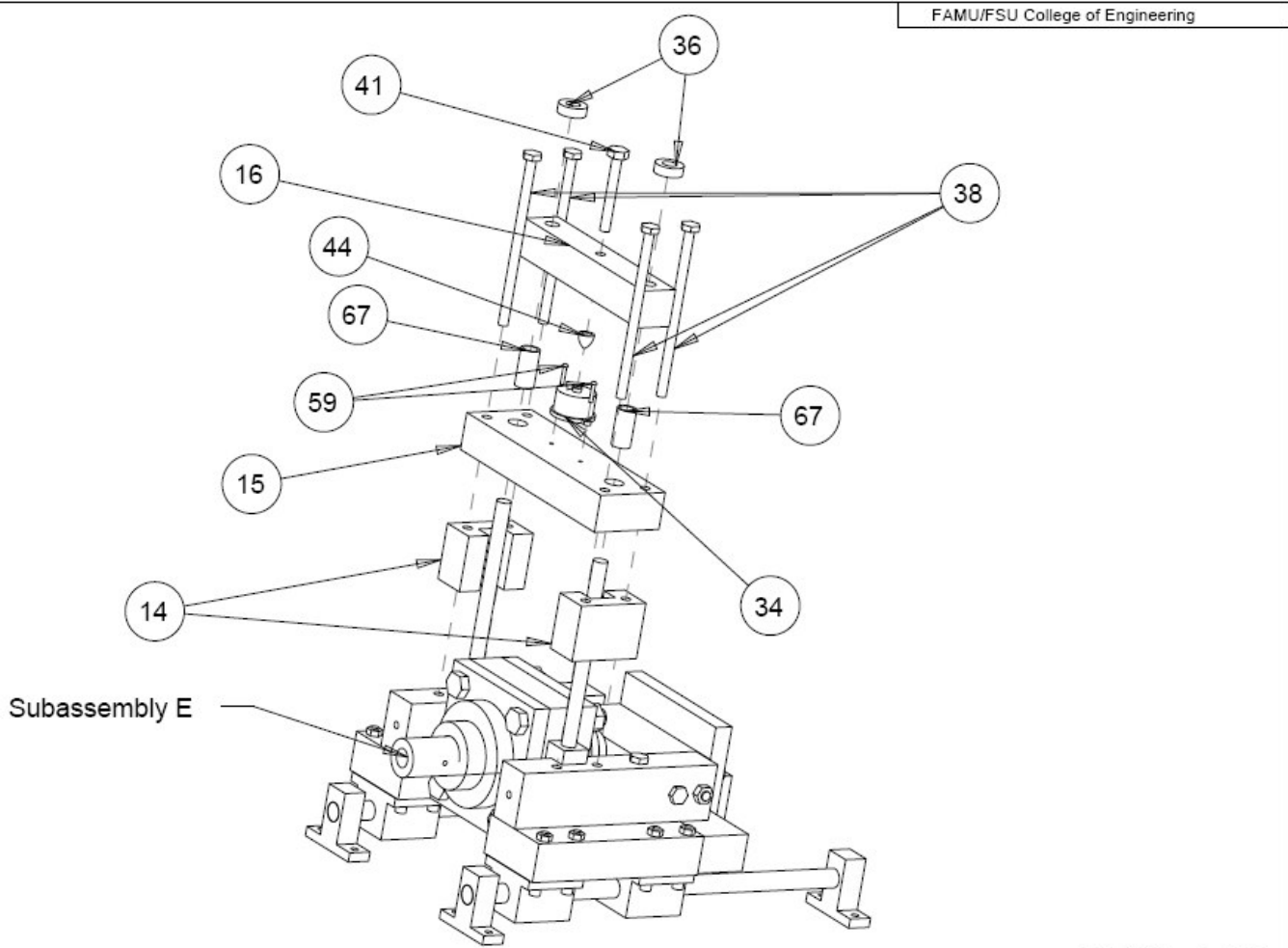

Cummins 2: Team 11

Part Name: Subassembly F Exploded

SCALE 0.300

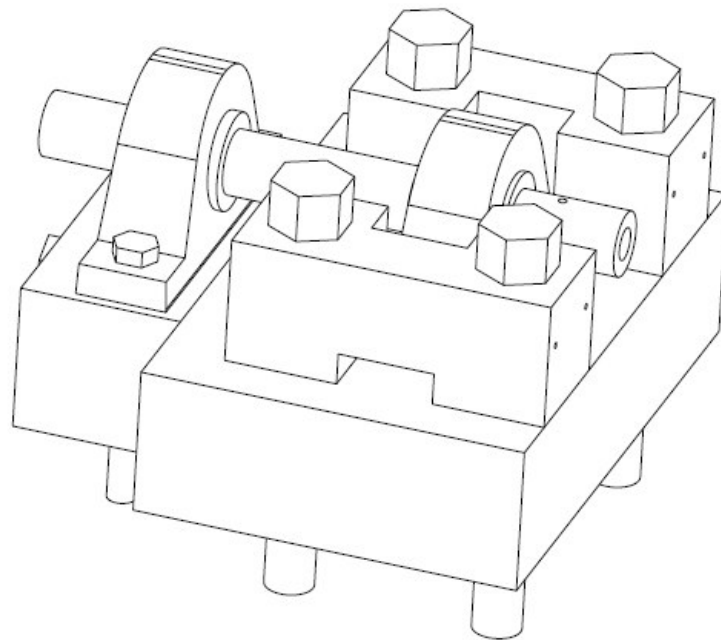

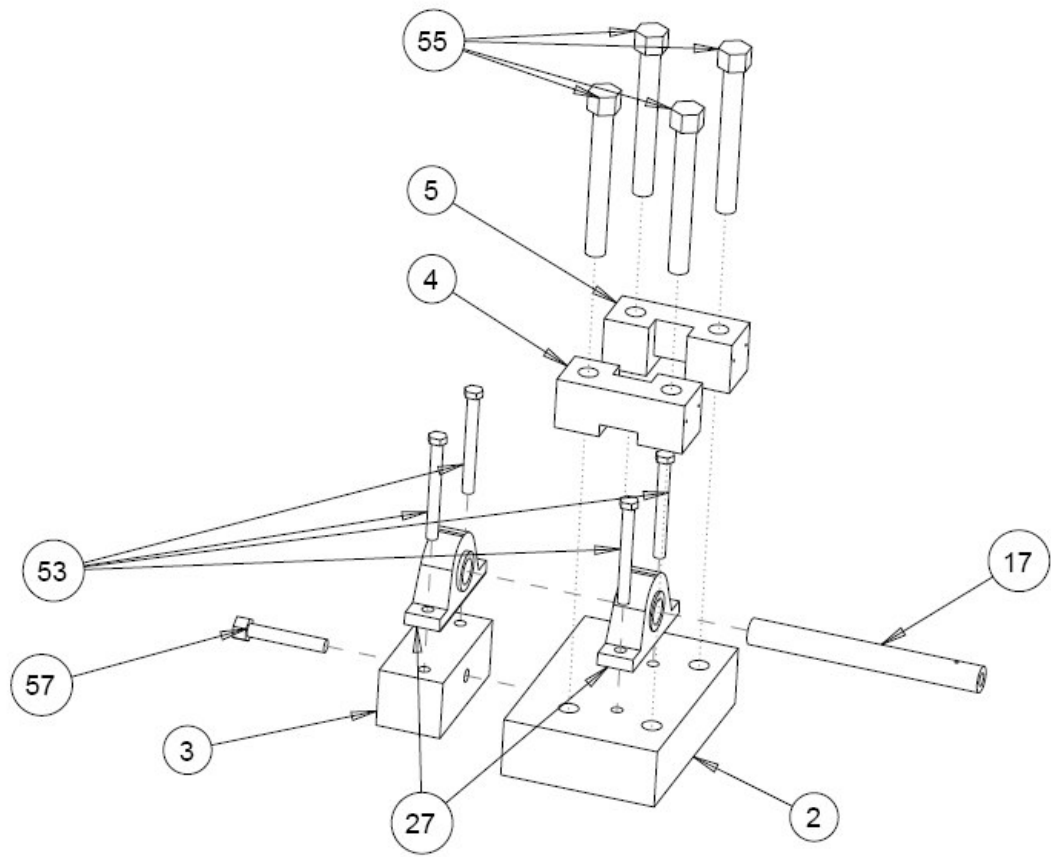

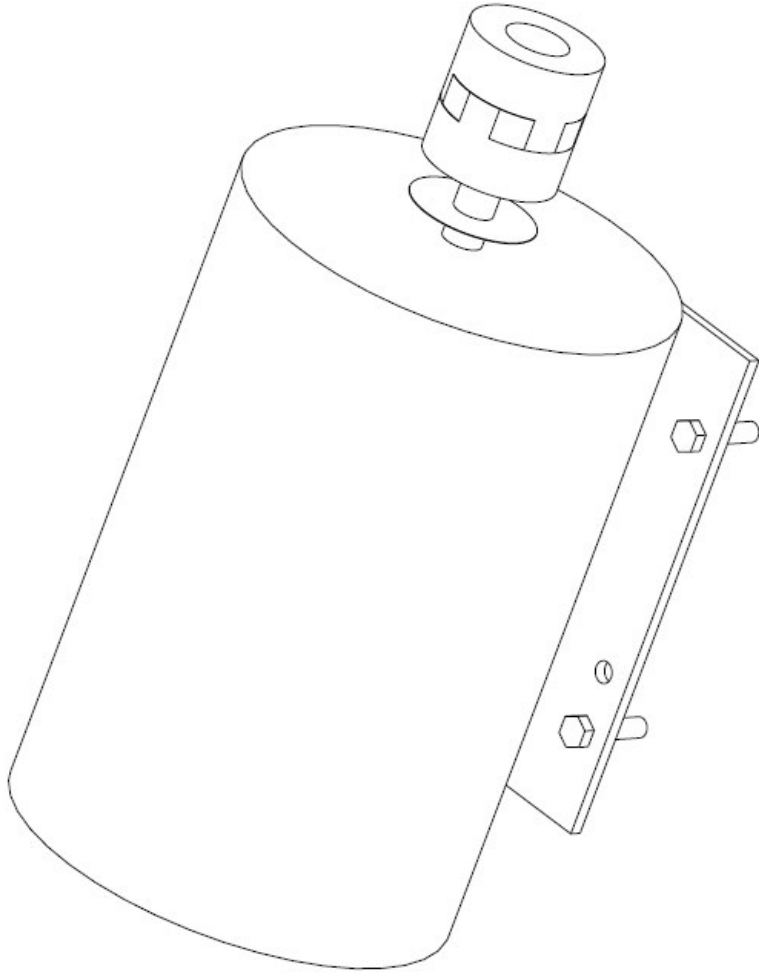

SCALE 0.500

Part Name: Subassembly H

Cummins 2: Team 11

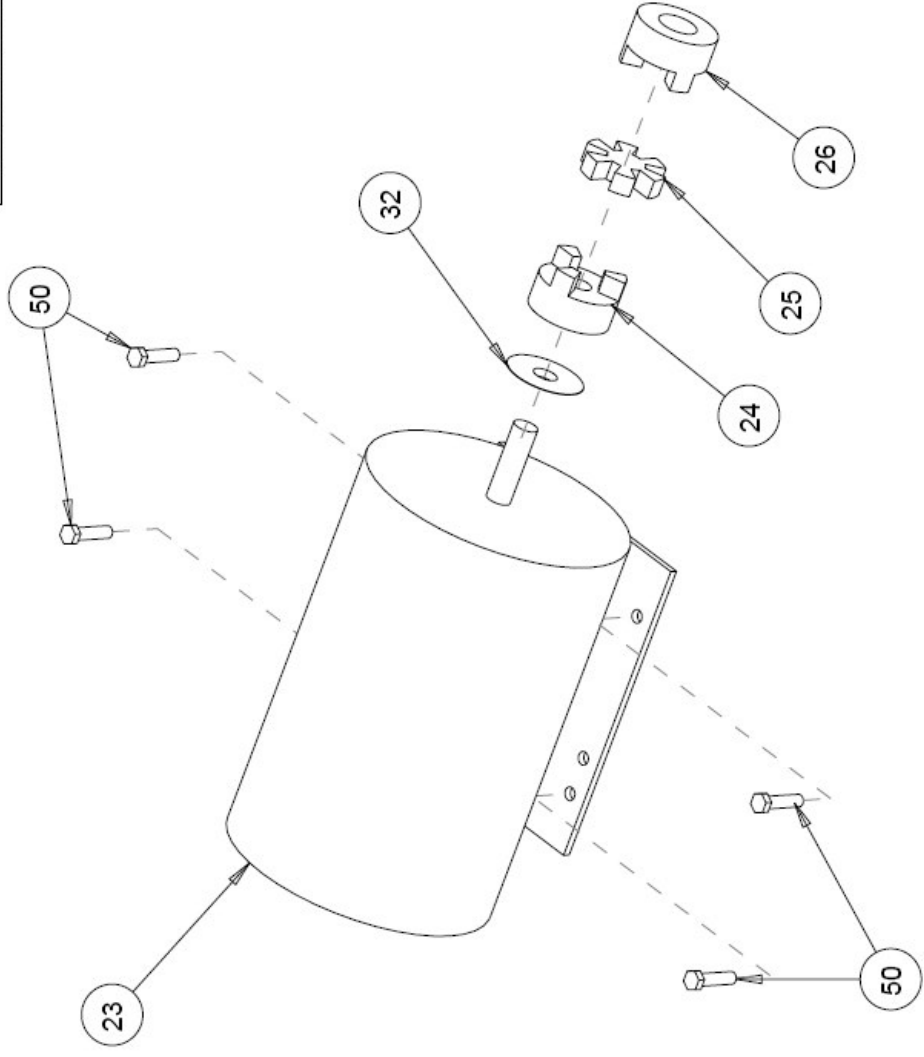

SCALE 0.300

Part Name: Subassembly H Exploded

Cummins 2: Team 11

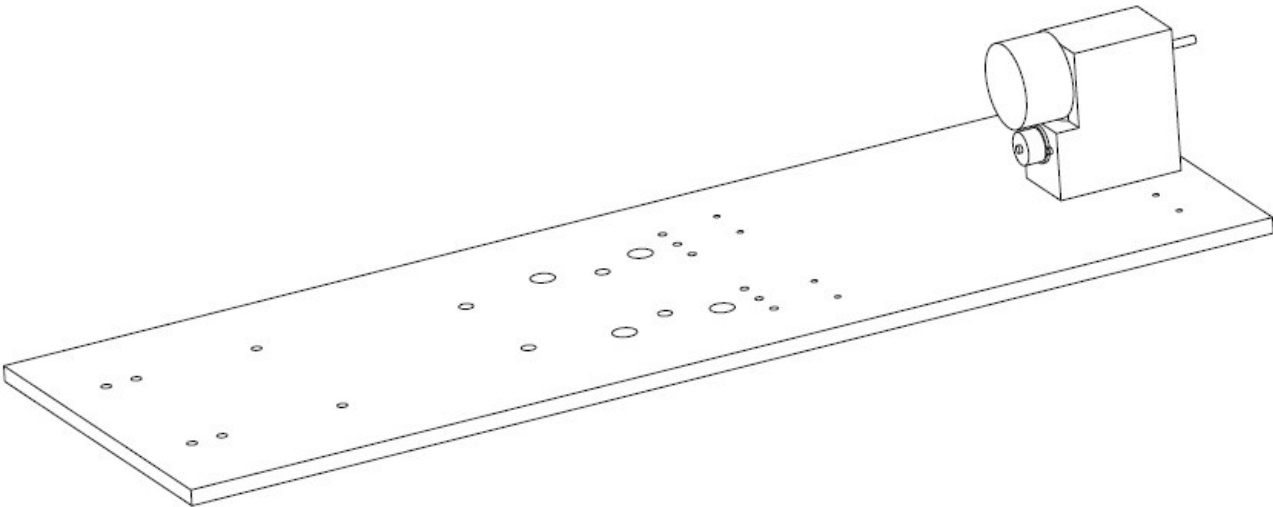

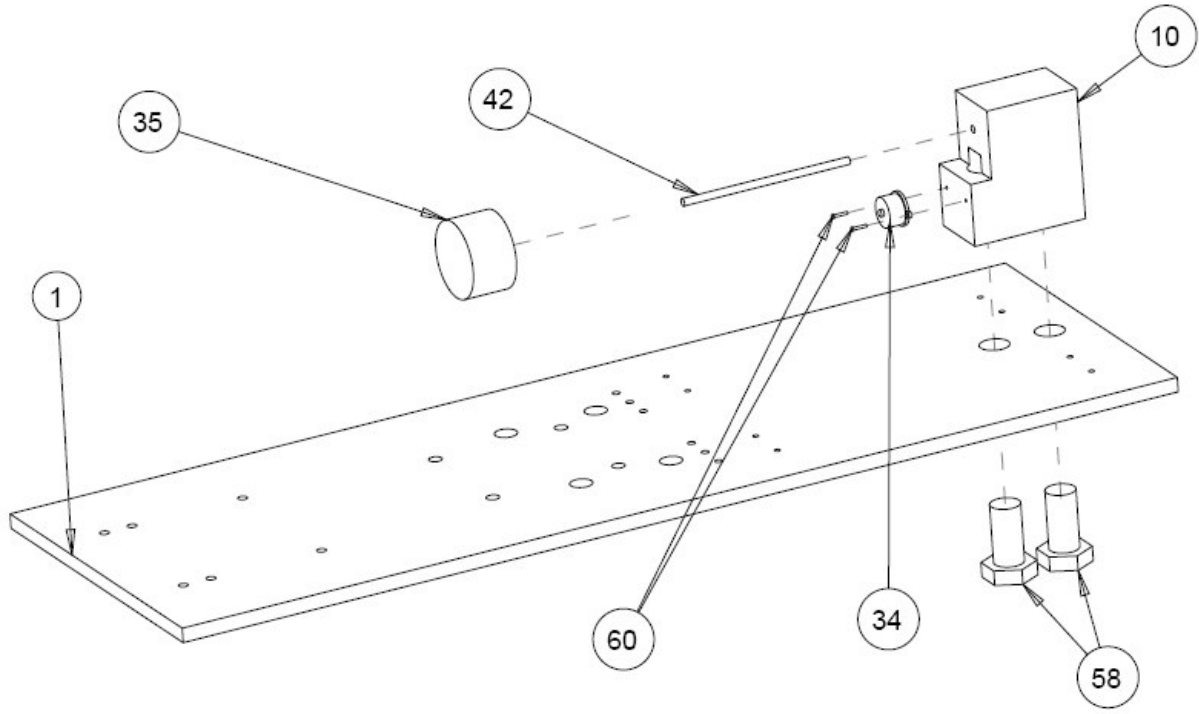

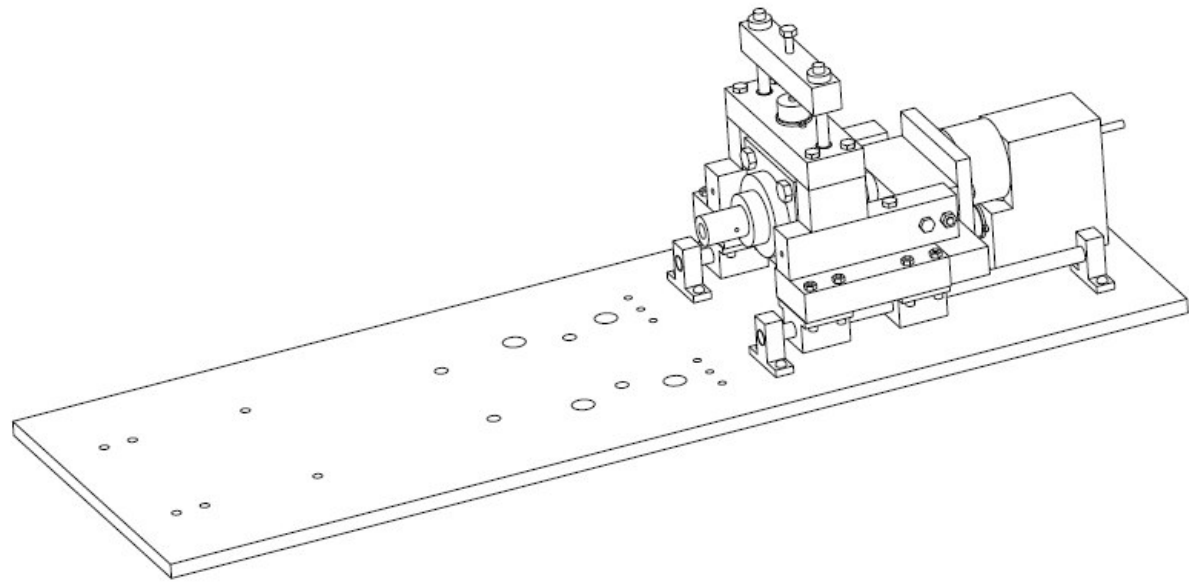

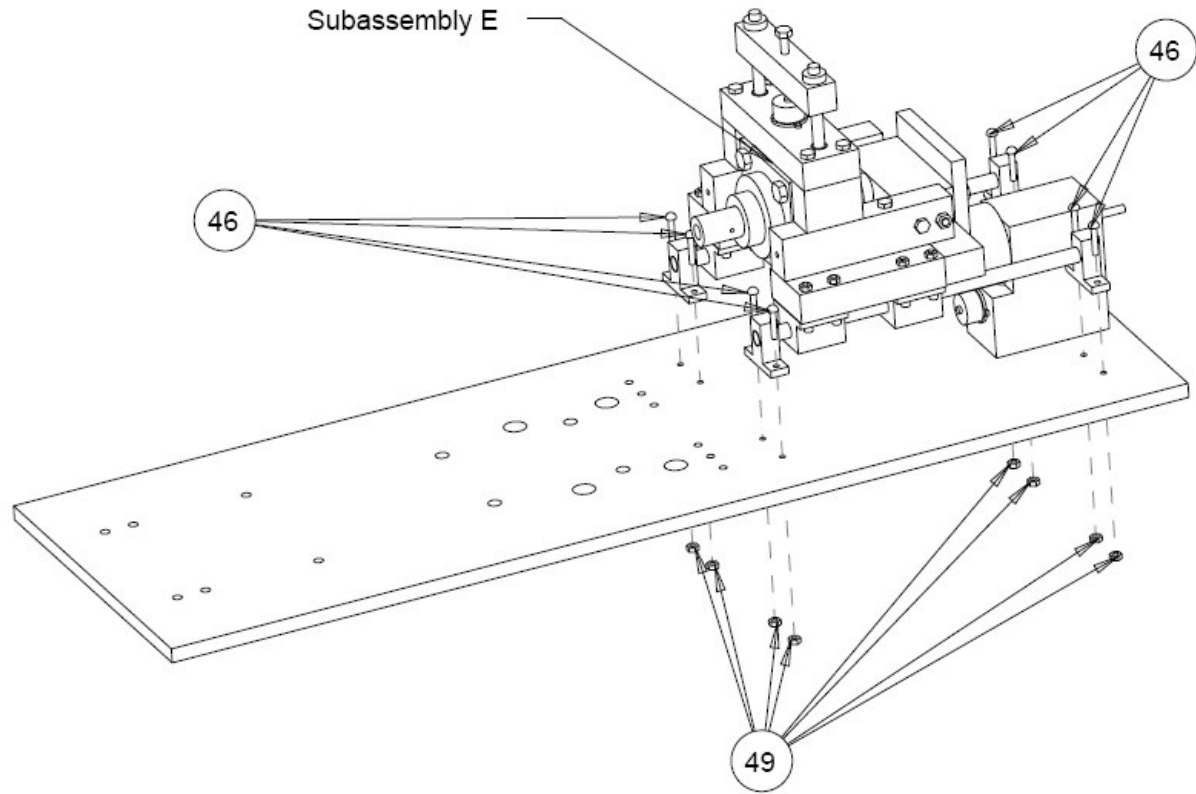

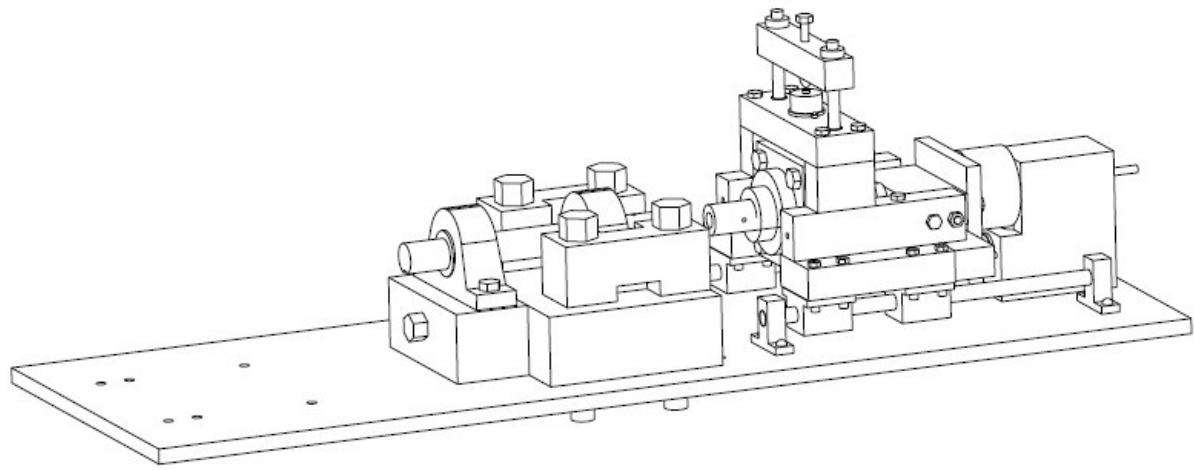

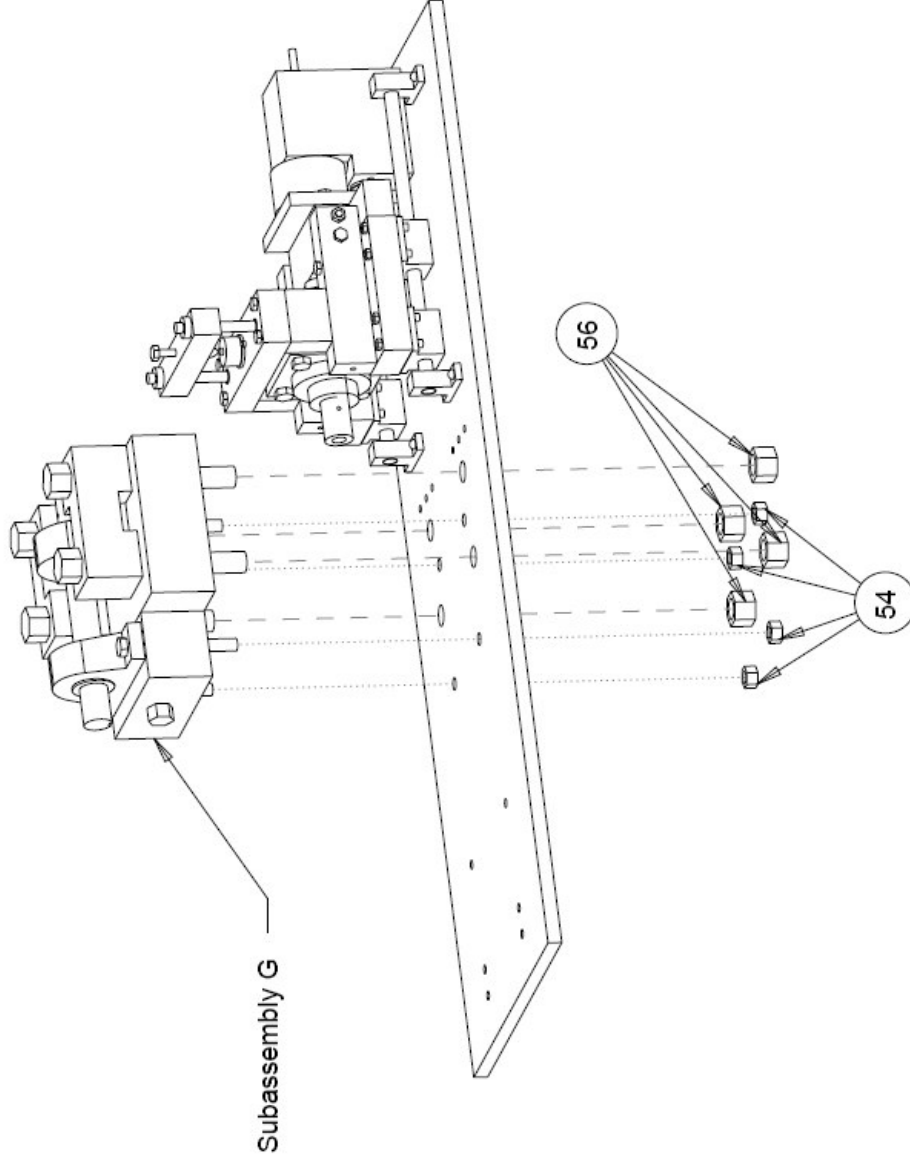

SCALE 0.210

Part Name: Final Assembly Step 3 Exploded

Cummins 2: Team 11

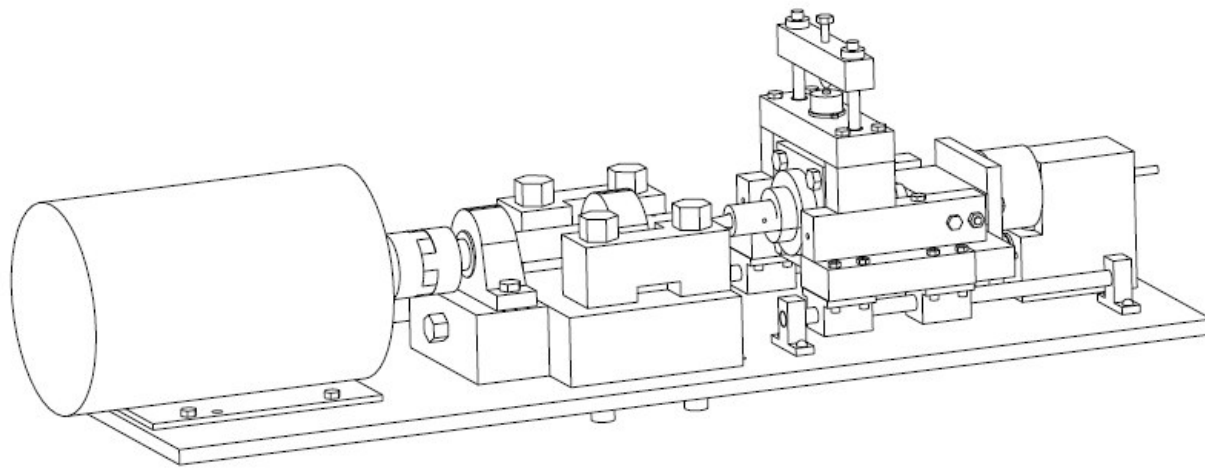

Subassembly H

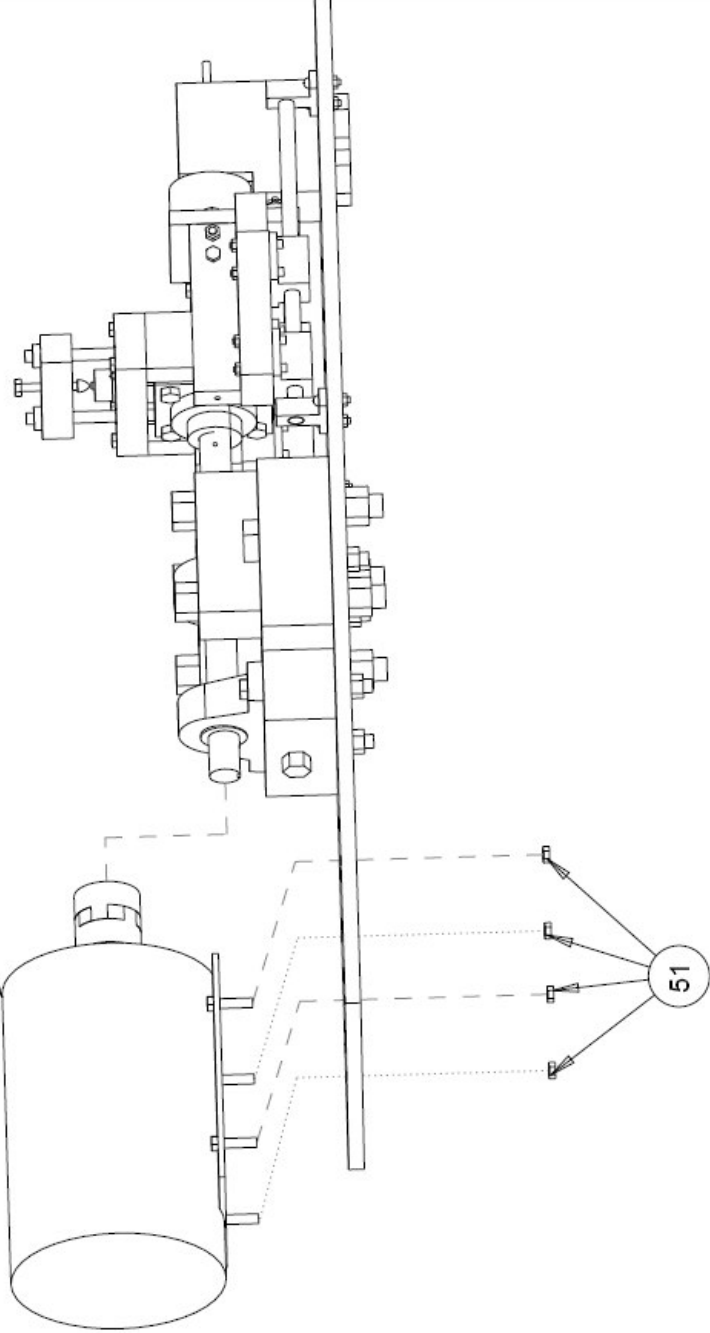

Steel

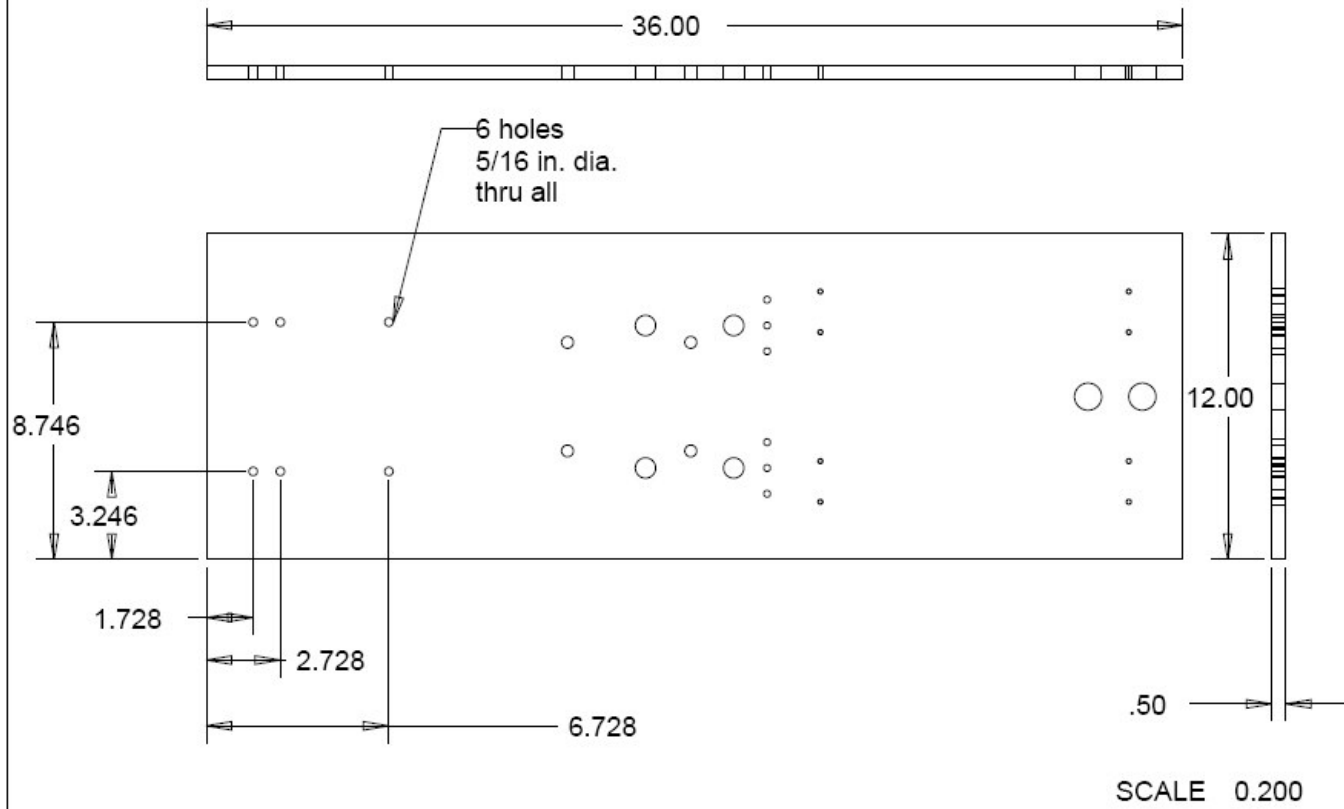

Cummins 2: Team 11	Part Name: Base (1 of 5)	Part Number:	Qty: 1	Mass: 67 lbs.
--------------------	--------------------------	--------------	--------	---------------

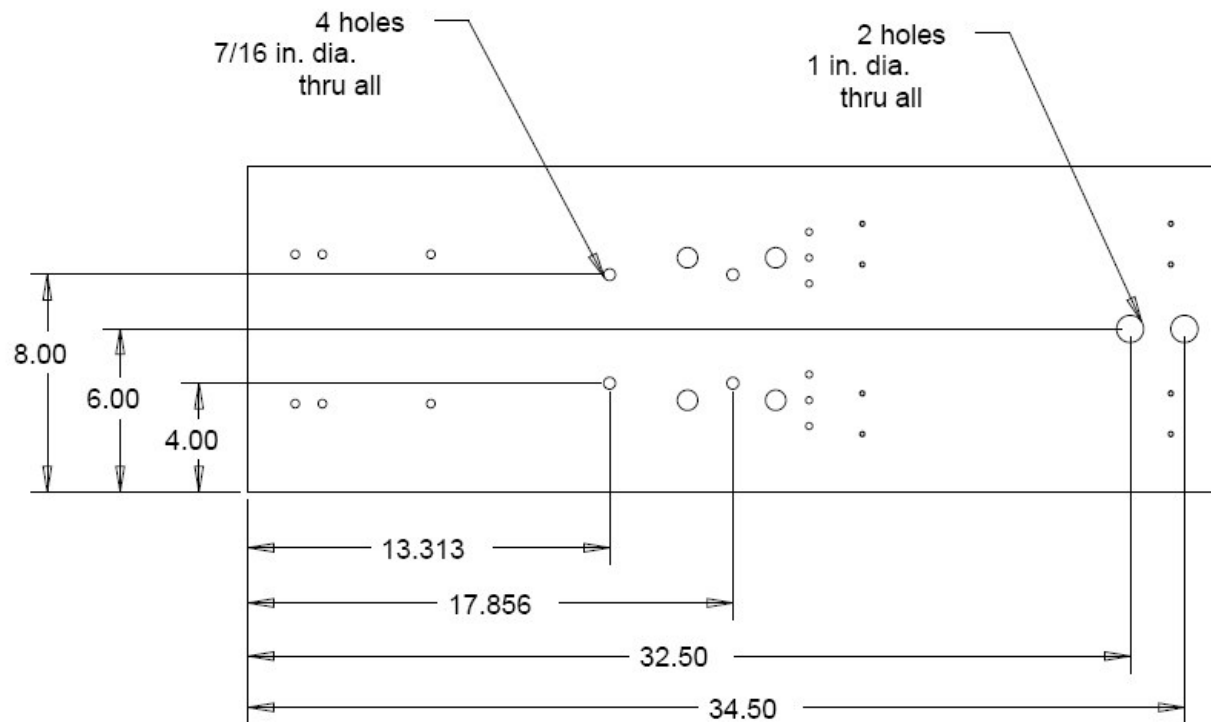

Cummins 2: Team 11	Part Name: Base (2 of 5)	Part Number: 1	Qty: 1	Mass: 67 lbs.
--------------------	--------------------------	----------------	--------	---------------



4 holes
3/4 in. dia.
thru all

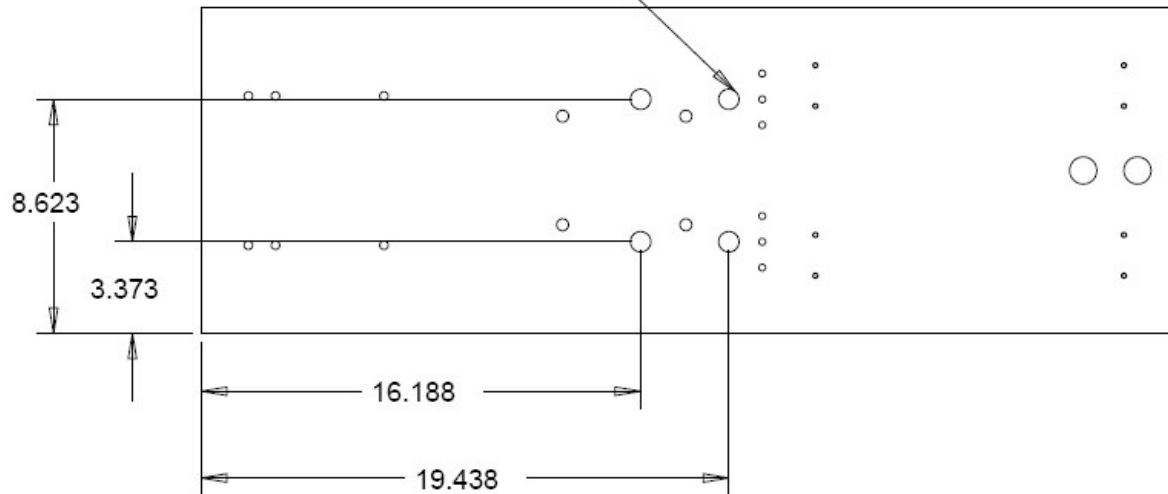

SCALE 0.200

Cummins 2: Team 11	Part Name: Base (3 of 5)	Part Number: 1	Qty: 1	Mass: 67 lbs.
--------------------	--------------------------	----------------	--------	---------------

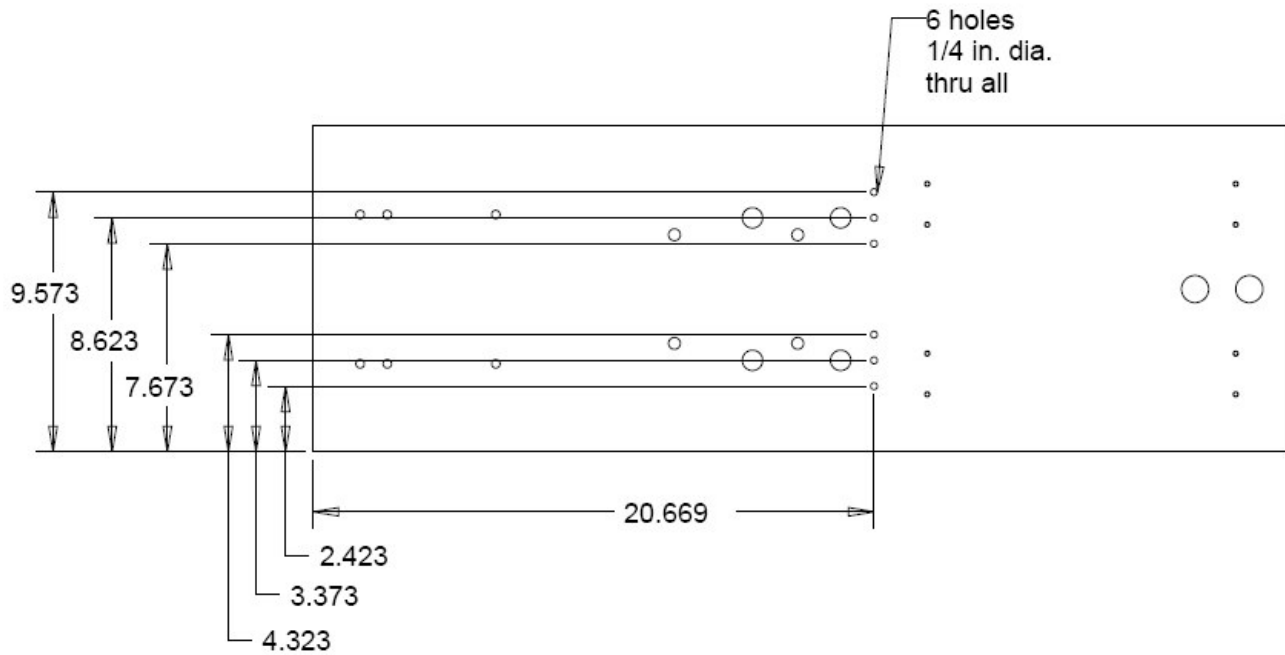

SCALE 0.200

Cummins 2: Team 11	Part Name: Base (4 of 5)	Part Number: 1	Qty: 1	Mass: 67 lbs.
--------------------	--------------------------	----------------	--------	---------------



8 holes
3/16 in. dia.
thru all

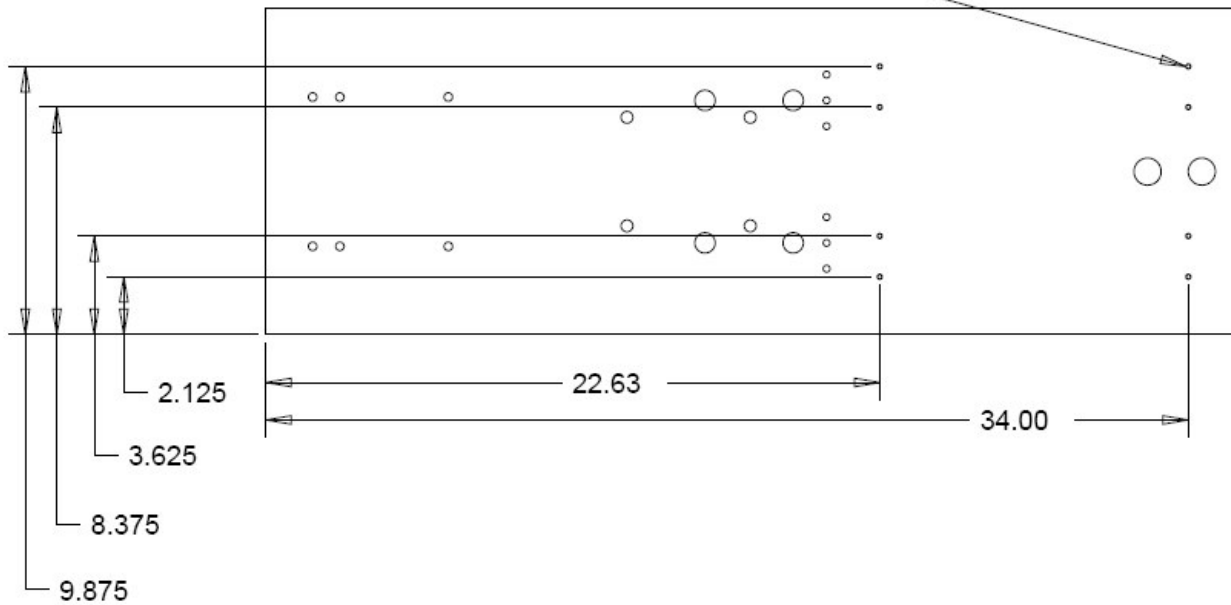

SCALE 0.200

Cummins 2: Team 11	Part Name: Base (5 of 5)	Part Number:1	Qty: 1	Mass: 67 lbs.
--------------------	--------------------------	---------------	--------	---------------

Aluminum 6061

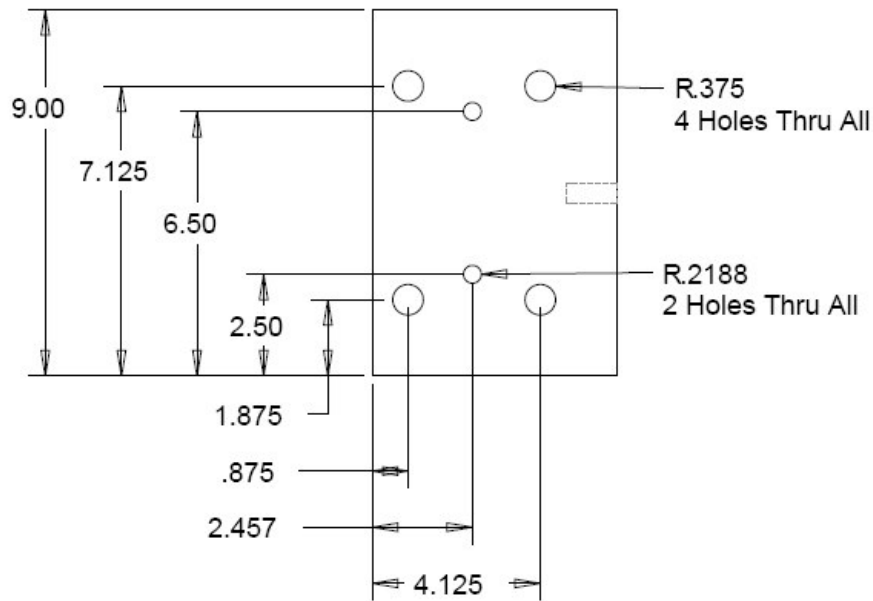
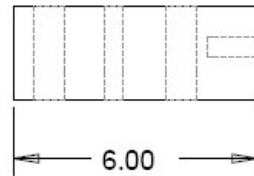

R.25
Drill 27/64
Tap 1/2-13
1.25 in. Depth

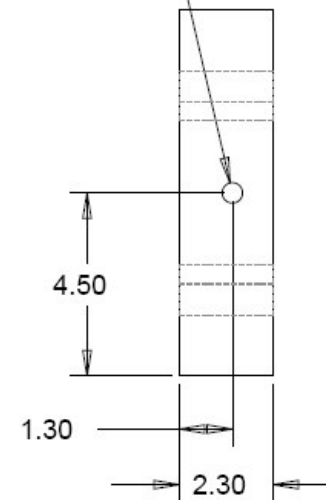

SCALE 0.300

Cummins 2: Team 11

Part Name: Large Spacer

Part Number: 2

Qty: 1

Mass: 11.2 lbs.



Aluminum 6061

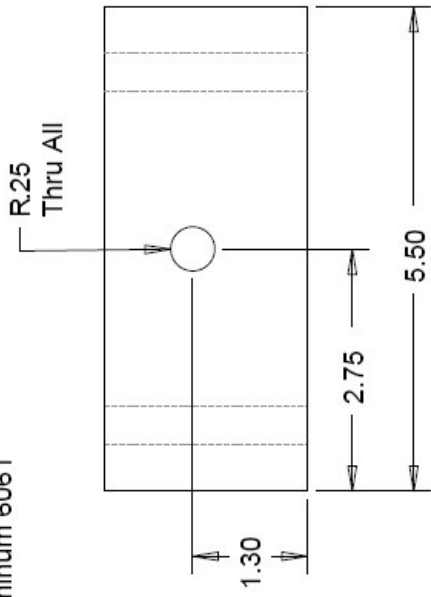

R.219
2 Holes Thru All

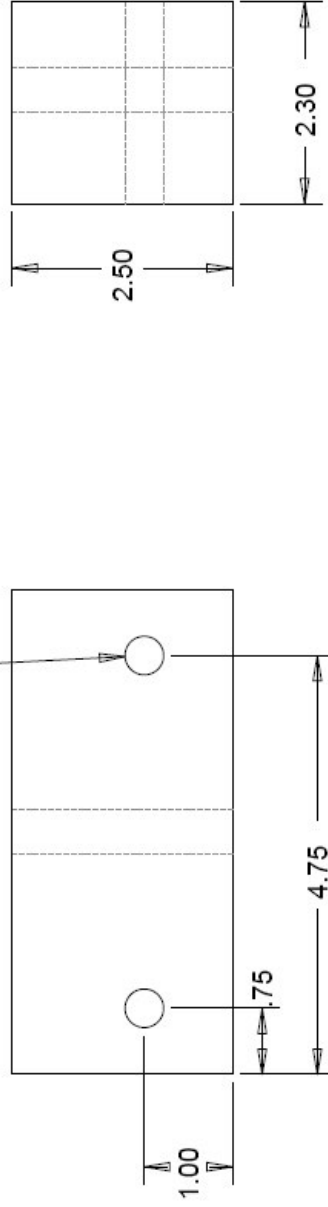

SCALE 0.650

Cummins 2: Team 11	Part Name: Small Spacer	Part Number: 3	Qty: 1	Mass: 3 lbs.
--------------------	-------------------------	----------------	--------	--------------

Aluminum 6061

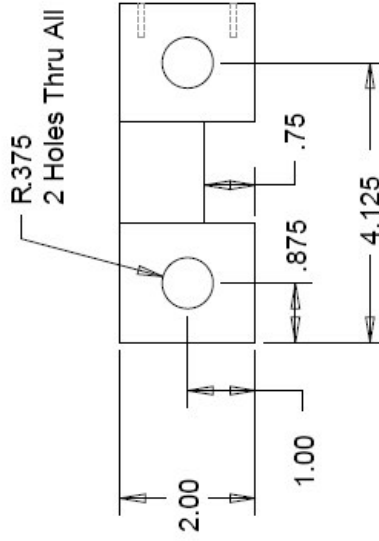
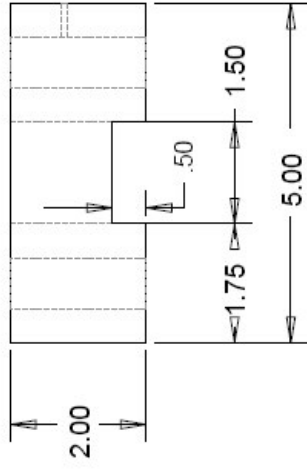
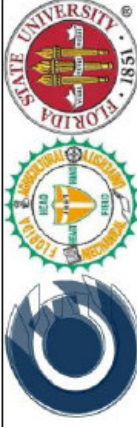

R045
Drill #36
Tap 6-32
2 Holes .5 in. Depth

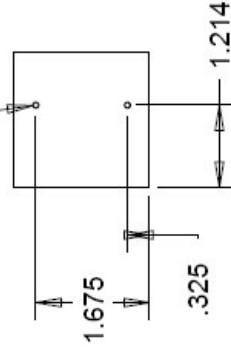

SCALE 0.500

Cummins 2: Team 11

Part Name: Mounted Support (Right)

Part Number: 4

Qty: 1

Mass: 1.47 lbs.

Aluminum 6061

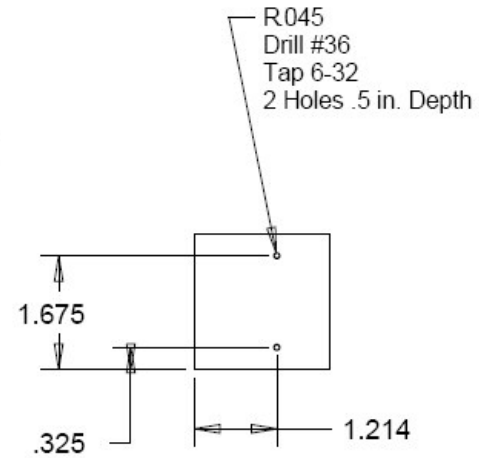
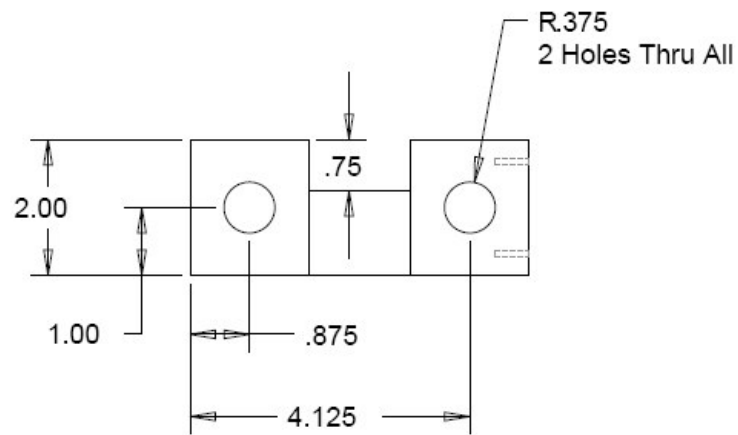
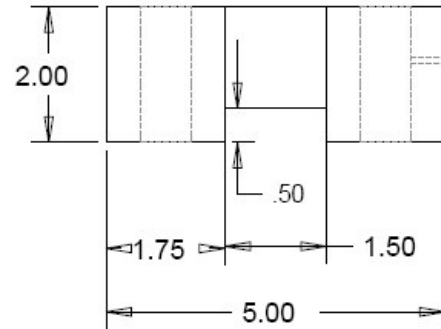

SCALE 0.500

Cummins 2: Team 11

Part Name: Mounted Support (Left)

Part Number: 5

Qty: 1

Mass: 1.47 lbs.

Aluminum 6061

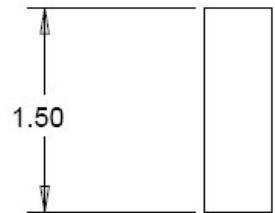
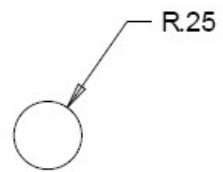

SCALE 1.000

Cummins 2: Team 11	Part Name: Pivot Pin	Part Number: 7	Qty: 2	Mass: .08 lbs.
--------------------	----------------------	----------------	--------	----------------

Aluminum 6061



R.1875
Drill 5/16
Tap 1/2-13
.5 in. Depth

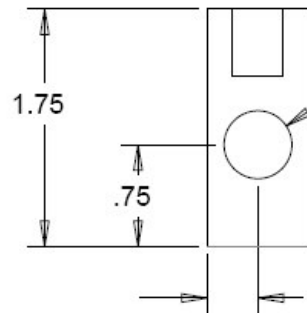
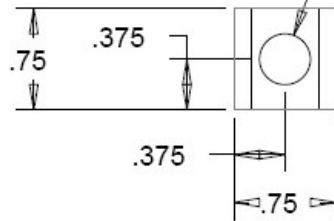

R.25
Thru All

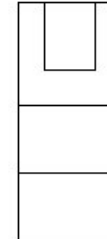

SCALE 1.000

Cummins 2: Team 11

Part Name: Vertical Track Guide

Part Number: 8

Qty: 2

Mass: .07 lbs.



Thread 3/8 - 16
1/2 in. down
both ends

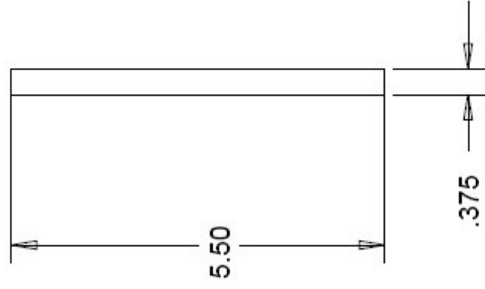

Cummins 2: Team 11	Part Name: Vertical Guide Rod	Part Number: 9	Qty: 2	Mass: .18 lbs.
--------------------	-------------------------------	----------------	--------	----------------

Aluminum 6061

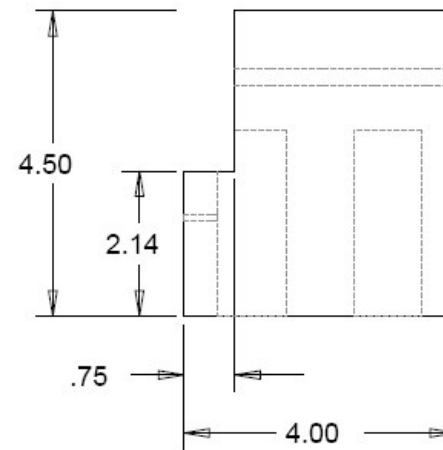
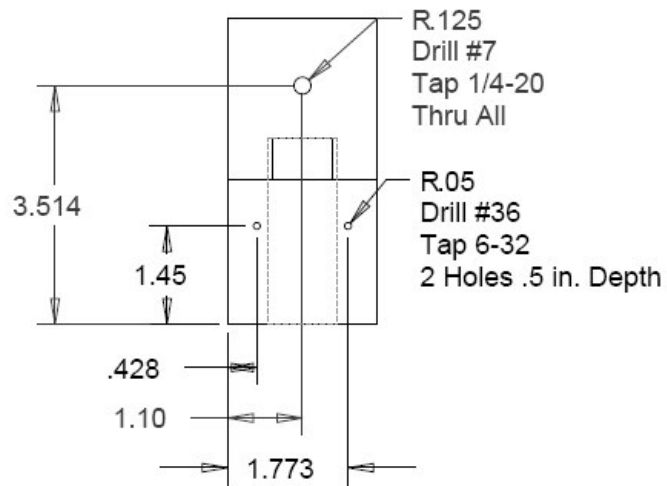
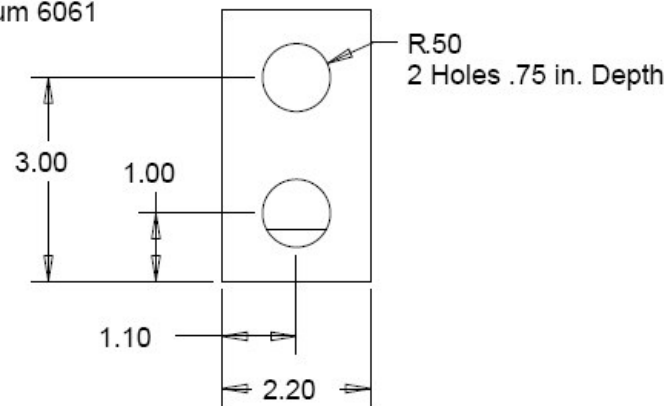

SCALE 0.500

Cummins 2: Team 11

Part Name: Rear Load Support

Part Number: 10

Qty: 1

Mass: 3.42 lbs.

Aluminum 6061

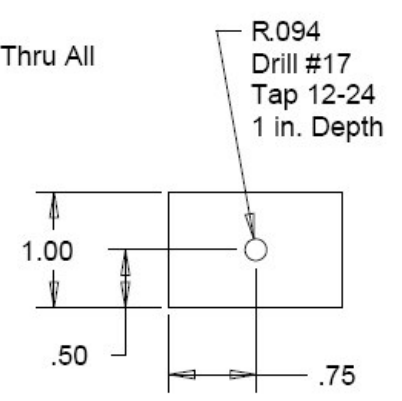
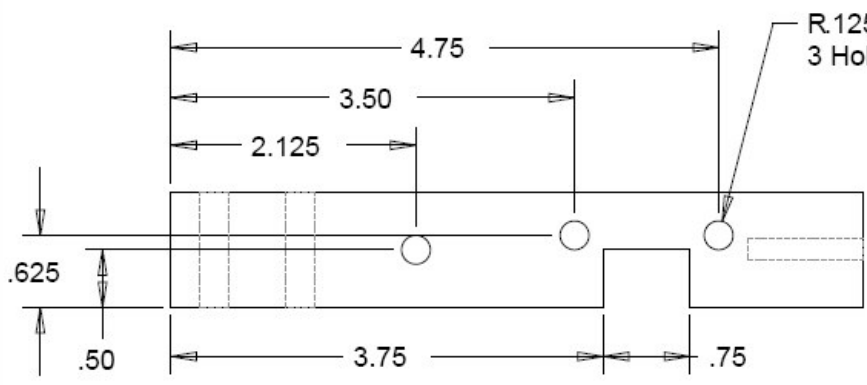
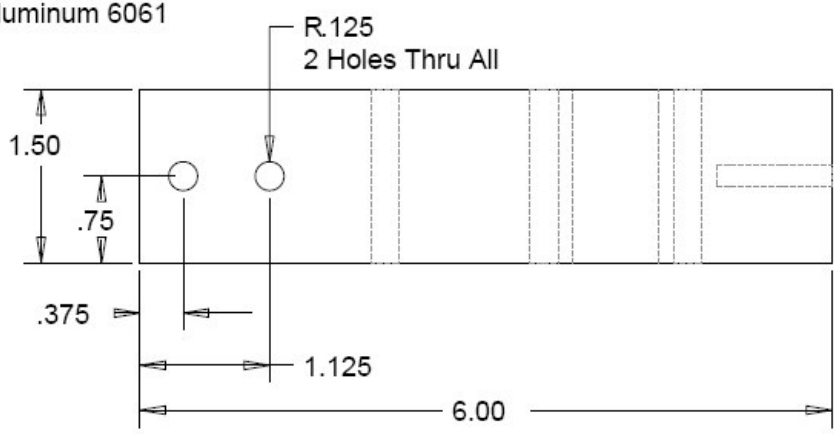

SCALE 0.850

Cummins 2: Team 11	Part Name: Vertical Track (Lower)	Part Number: 11	Qty: 2	Mass: .79 lbs.
--------------------	-----------------------------------	-----------------	--------	----------------

Aluminum 6061

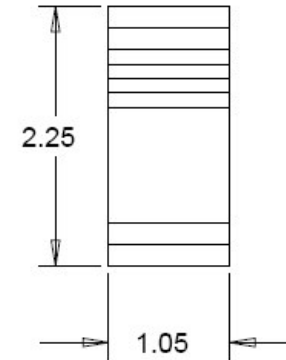
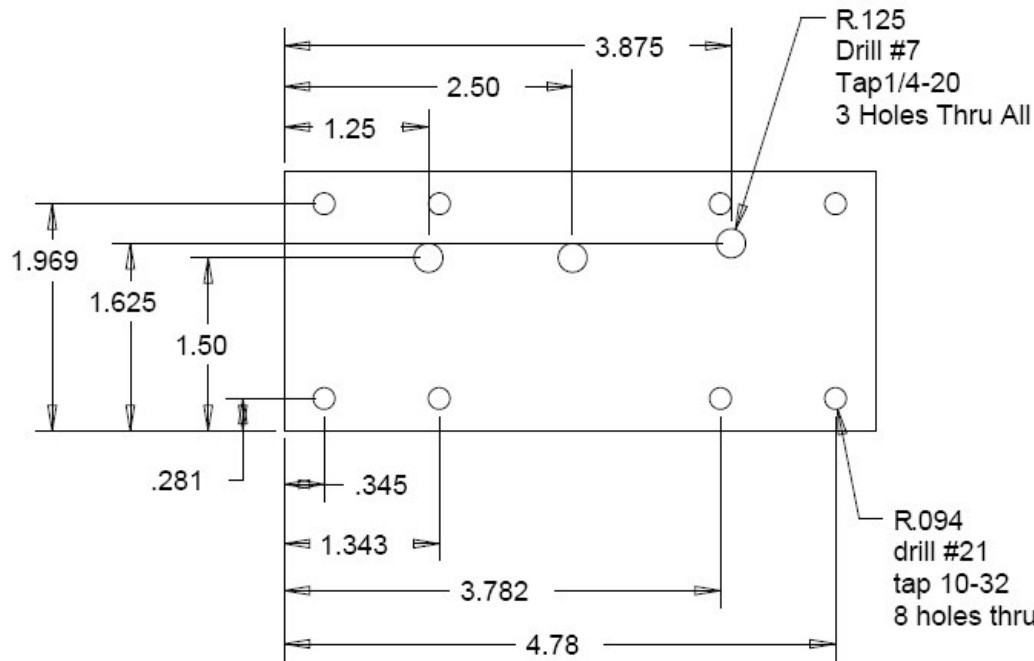
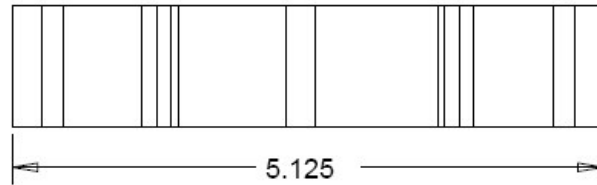

SCALE 0.850

Cummins 2: Team 11	Part Name: Linear Bearing Mount	Part Number: 12	Qty: 2	Mass: 1.17 lbs.
--------------------	---------------------------------	-----------------	--------	-----------------

Aluminum 6061

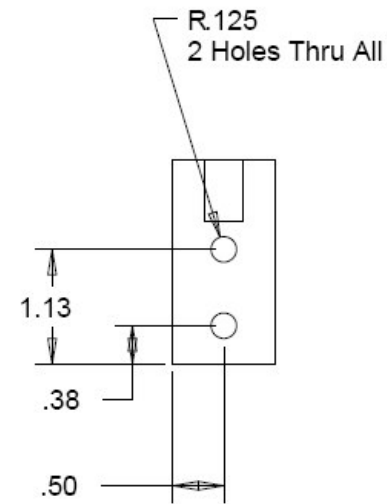
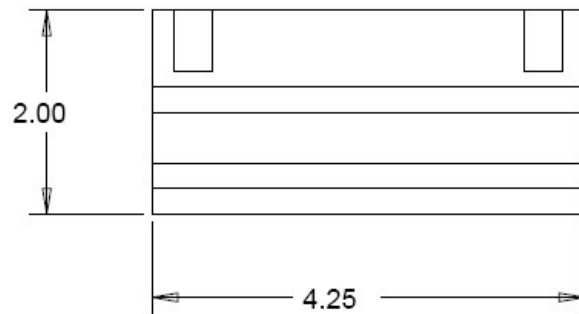
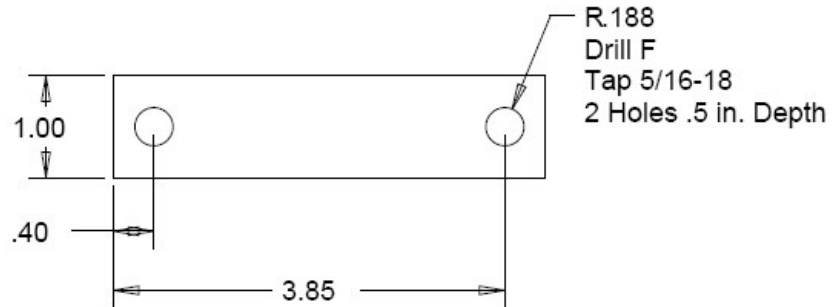

SCALE 0.750

Cummins 2: Team 11

Part Name: Platform Connector

Part Number: 13

Qty: 1

Mass: .75 lbs

Aluminum 6061

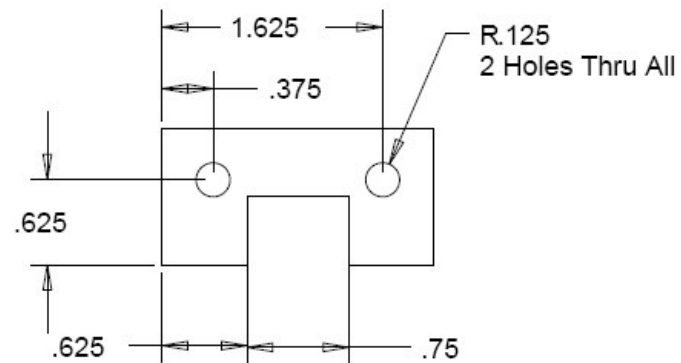
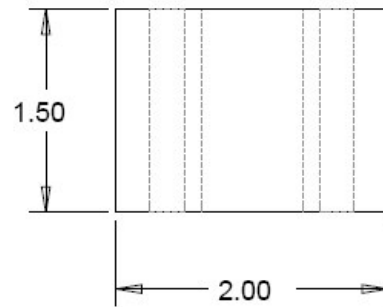

SCALE 1.000

Cummins 2: Team 11

Part Name: Vertical Support

Part Number: 14

Qty: 2

Mass: .21 lbs.

Aluminum 6061

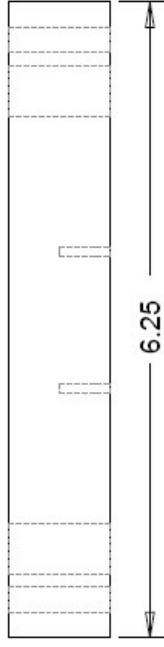

R.125
4 Holes Thru All

R.045
Drill #36
Tap 6-32
2 Holes .5 in. Depth

R.25
2 Holes Thru All

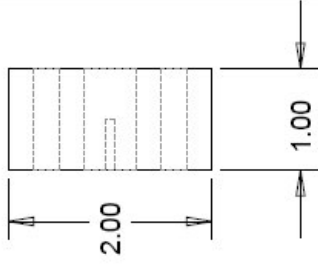
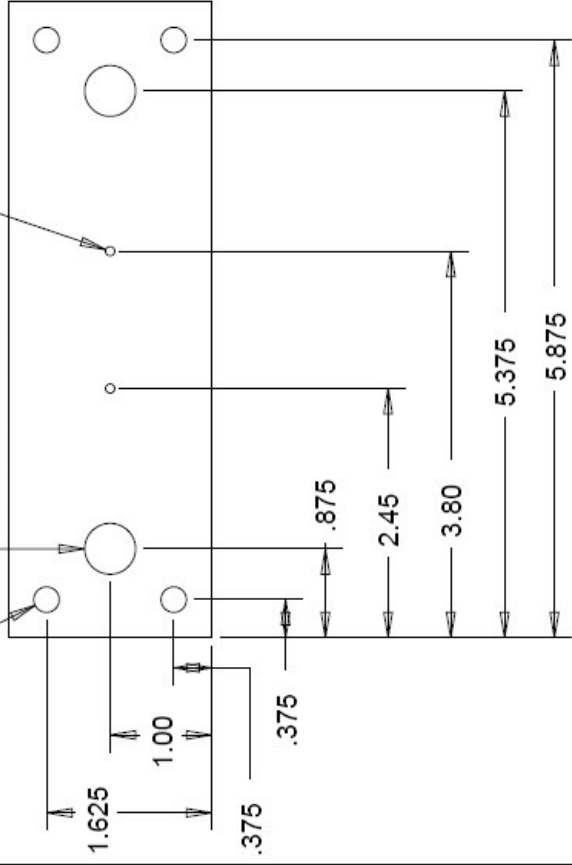

SCALE 0.750

Cummins 2: Team 11	Part Name: Vertical Load Cell Mount	Part Number: 15	Qty: 1	Mass: 1.13 lbs.
--------------------	-------------------------------------	-----------------	--------	-----------------

Aluminum 6061

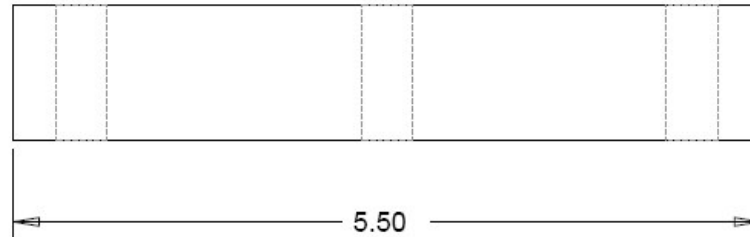

R.1875
2 Holes Thru All

R.1875
Drill #3
Tap 1/4-28
Thru All

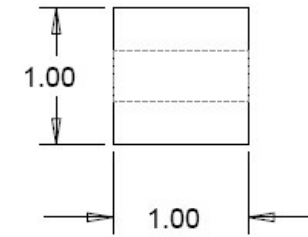
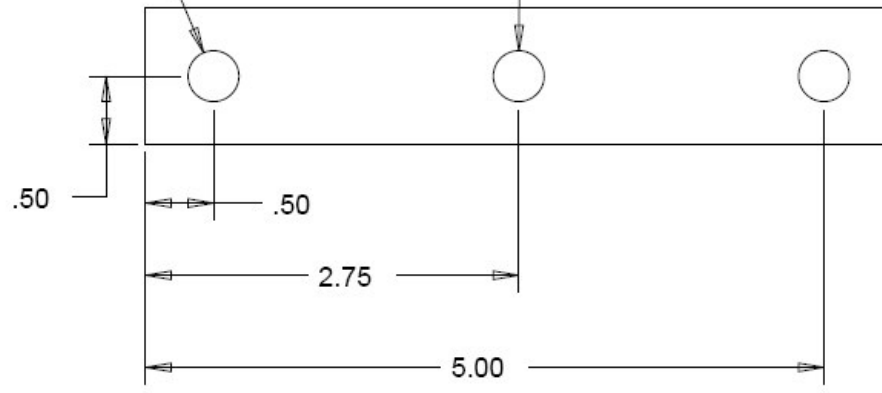

SCALE 1.000

Cummins 2: Team 11	Part Name: Top Bar	Part Number: 16	Qty: 1	Mass: .51 lbs.
--------------------	--------------------	-----------------	--------	----------------

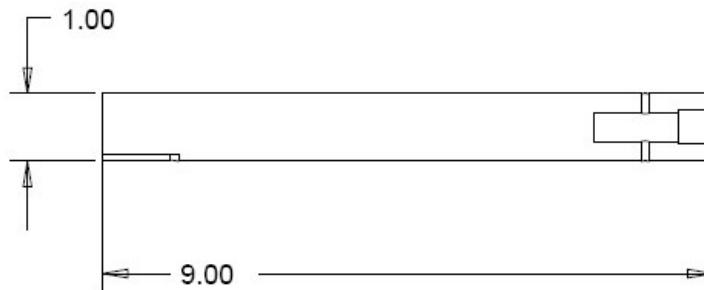
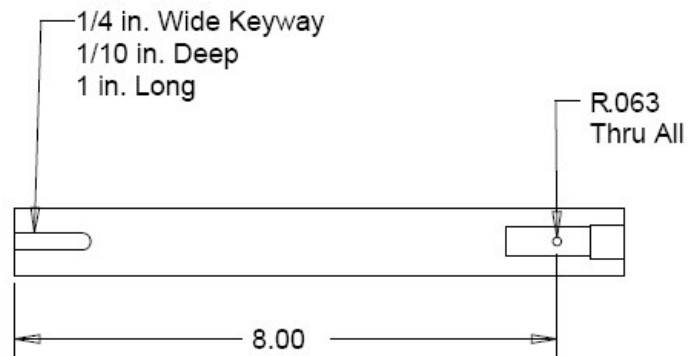

R.25
1 Hole .5 in. Depth



R.211
Drill 27/64
Tap 1/2-13
1 Hole 1.75 in. Depth

Cummins 2: Team 11

Part Name: Main Shaft

Part Number: 17

Qty: 1

Mass: 1.87 lbs

Stainless Steel



R.25
.5 in. Depth

R.21
Drill 27/64
Tap 1/2-13

R.50

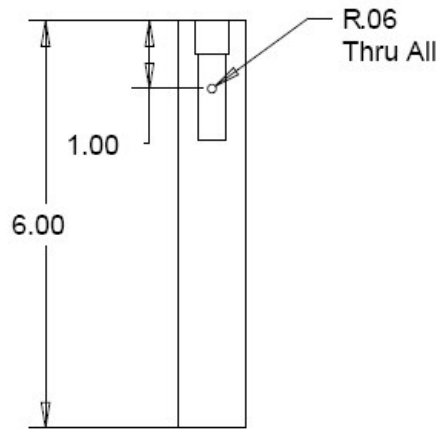

Cummins 2: Team 11

Part Name: Right Grip

Part Number: 18

Qty: 1

Mass: 1.21 lbs.

Steel

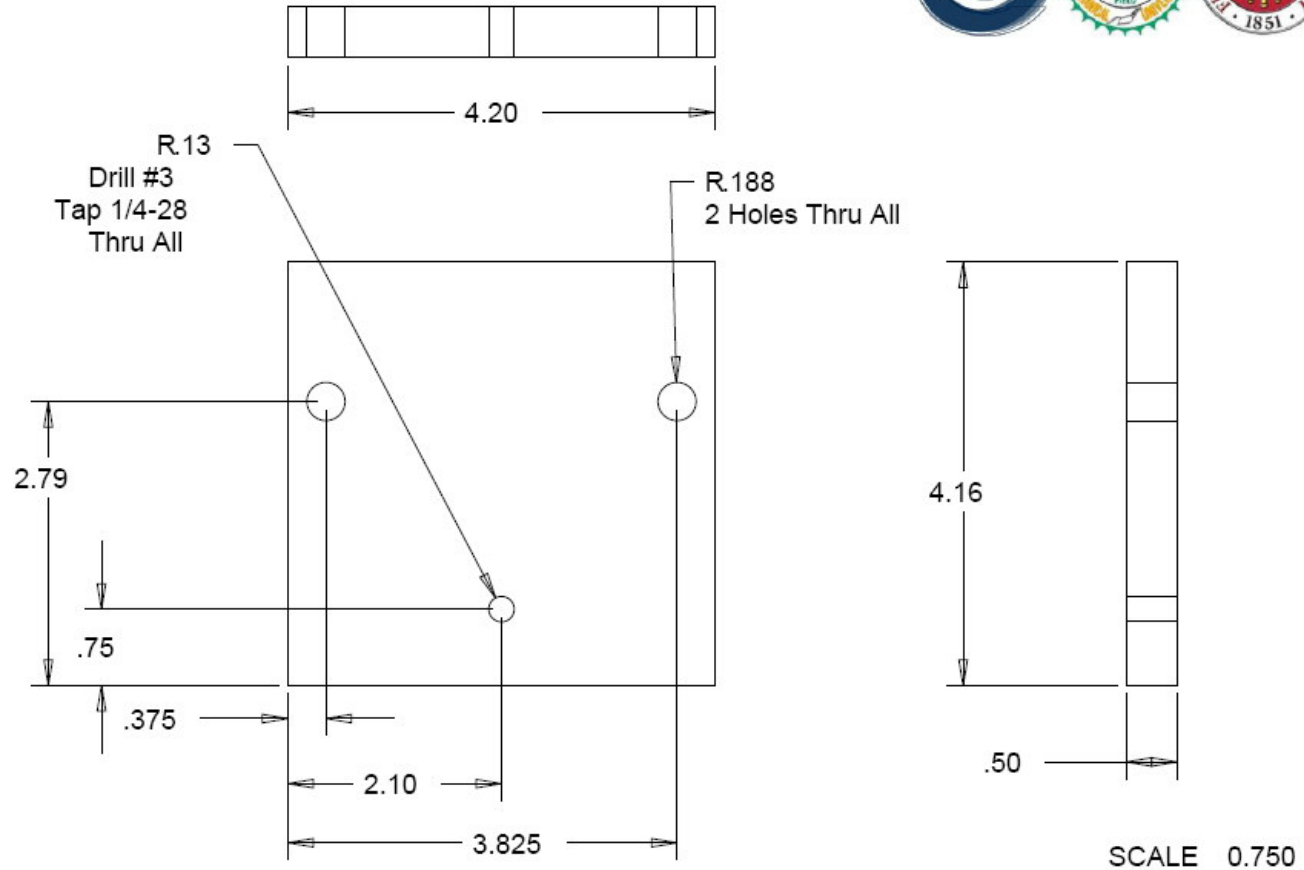

Cummins 2: Team 11	Part Name: Steel Plate	Part Number: 19	Qty: 1	Mass: 2.4 lbs.
--------------------	------------------------	-----------------	--------	----------------

Stainless Steel

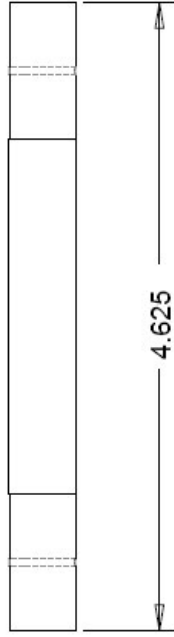

R.24
Thread 1/2-13
Two Sides 1 in. Depth

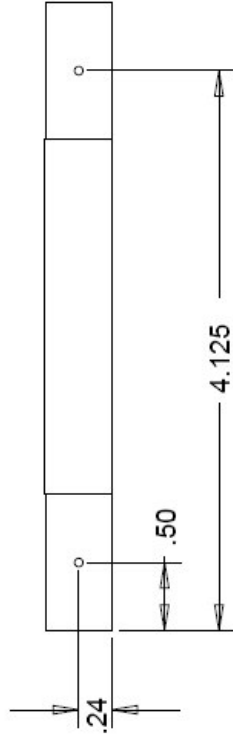

Cummins 2: Team 11

Part Name: Specimen Blank

Part Number: 20

Qty: 1

Mass: .22 lbs.

Aluminum 6061

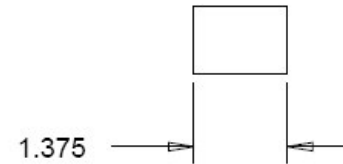
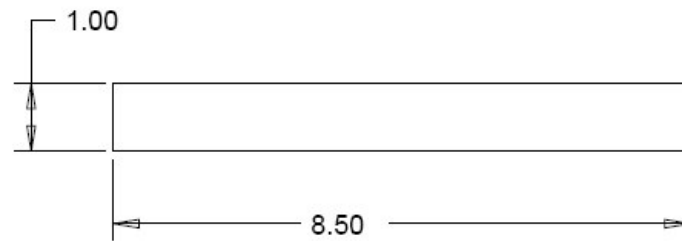

SCALE 0.500

Cummins 2: Team 11

Part Name: Rear Brace

Part Number: 21

Qty: 1

Mass: 1.14 lbs.

Gray Cast Iron Class 20

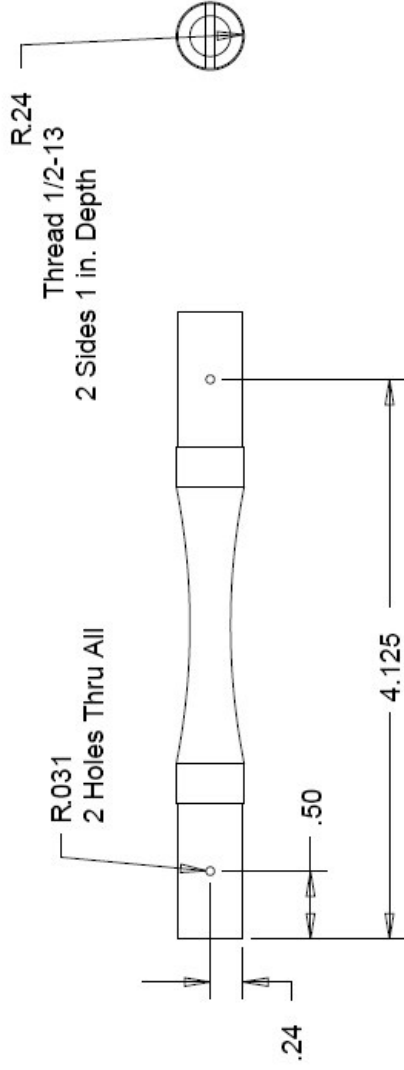
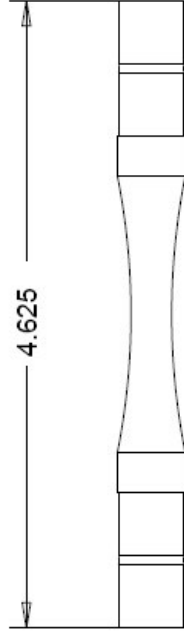

Cummins 2: Team 11

Part Name: Specimen

Part Number: 22

Qty: N.A.

Mass: .16 lbs.

Appendix E

Catalog Page Information for Selected Parts

Part 7 and 20: Steel rod (1/2"x 12")

Tight-Tolerance Undersize Rods— Precision Ground Finish



- Hardness: 200-255 Brinell
- Yield Strength: Not rated
- Annealed

Dia.	1 ft.		3 ft.	
	Part No.	Price	Part No.	Price
1/2"	88915K22	13.23		28.09

McMASTER-CARR

Part 17: Stainless steel shaft 1"x12"



- Hardness: 1/8"-2 1/2" dia. 170 to 241 Brinell; 2 5/8"-4" dia. 241 Brinell
- Yield Strength: 40,000 psi
- Annealed

Dia.	Part No.	Each			Dia.
		1 ft.	3 ft.	6 ft.	
1"	89095K23	\$19.50	\$48.80	\$82.33	1 15/16"

McMASTER-CARR

Part 22: Specimen (before machining)

<http://www.laboratorydevicesco.com/FATIGUES.html>

CAST IRON

CFR20

GRAY 20

\$11.00

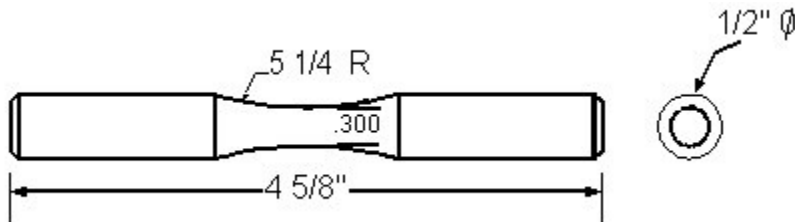

Part 23: Motor

Worldwide Electric 1/3 HP 56C frame, three phase electrical motor



Worldwide Electric 1/3 HP, 1800 rpm, 208-230/460 3 phase voltage, 56C frame, TEFC, 1.15 service factor. Worldwide Electric part number AT13-18-56CB. Fremont Industrial Supply, Inc

Picture from Fremont Industrial Supply, Inc

Part 24: Spider Hub

(5/8 in. dia. bore), Part 24 Spider, and Part 25 Spider Hub (1 in. dia. bore)

With Solid Spider

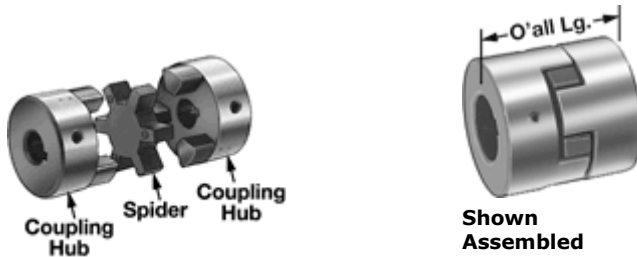

McMASTER-CARR

Part 35: Electromagnet

Electromagnet, Tubular, Low Profile, 2.63" (67 mm) DIA X 1.56" (40 mm) L

electromechanicsonline.com

MAGNETIC SENSOR SYSTEMS

Tubular Electromagnet

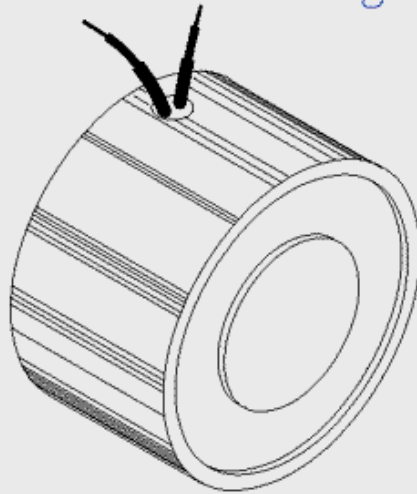

Series E-16-260
2 5/8" DIA X 1.56"
[66.8 mm X 39.6 mm]

TOTAL WEIGHT: 29.5 OUNCES [836 GR]

duty cycle maximum "ON" time, (Sec.)	1 (100%) ∞	1/2 (50%) 2000	1/4 (25%) 600	1/10 (10%) 120
watts	5	10	20	50
approximate ampere turns	600	850	1200	1900

AWG number	resistance (Ω)	volts DC	volts DC	volts DC	volts DC
19	1.4	2.6	3.6	5.2	8.1
20	1.8	2.9	4.1	5.8	9.1
21	3.0	3.8	5.4	7.7	12.1
22	4.5	4.8	6.8	9.6	15.2
23	7.8	6.1	8.6	12.1	19.1
24	12.0	7.7	10.9	15.5	24.5
25	18.5	9.6	13.5	19.1	30.3
26	32.5	12.5	17.7	25.1	39.7
27	48.4	15.7	22.2	31.4	49.6
28	75.2	19.8	28.0	39.6	62.6
29	127	25.4	36.0	50.9	80.4
30	201	31.7	44.9	63.4	100
31	313	39.1	55.4	78.3	124
32	469	48.8	69.0	97.6	154
33	770	62.1	87.8	124	196
34	1330	80.3	114	161	254
35	2257	103	146	207	327
36	3225	128	181	256	404

HEAT SINK: For proper heat dissipation, body of electromagnet should be mounted on an equivalent of 3.0" x 3.0" x 1/4" metal plate in an unrestricted flow of air.

6901 Woodley Avenue, Van Nuys, California 91406
 Telephone: (818) 785-6244 Fax: (818) 785-5713
www.solenoidcity.com

MAGNETIC SENSOR SYSTEMS

E-16-260

MECHANICAL DIMENSIONS

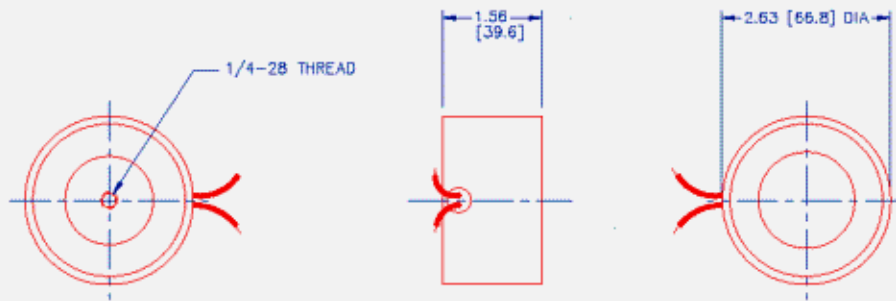

TOLERANCES: (UNLESS NOTED)
 0.XXX: ±0.005
 0.XX : ±0.010
 X/X: ±1/64
 COIL RESISTANCE: ±10%
 DIMENSIONS IN INCHES [mm]

TYPICAL HOLD FORCE VERSUS INPUT POWER

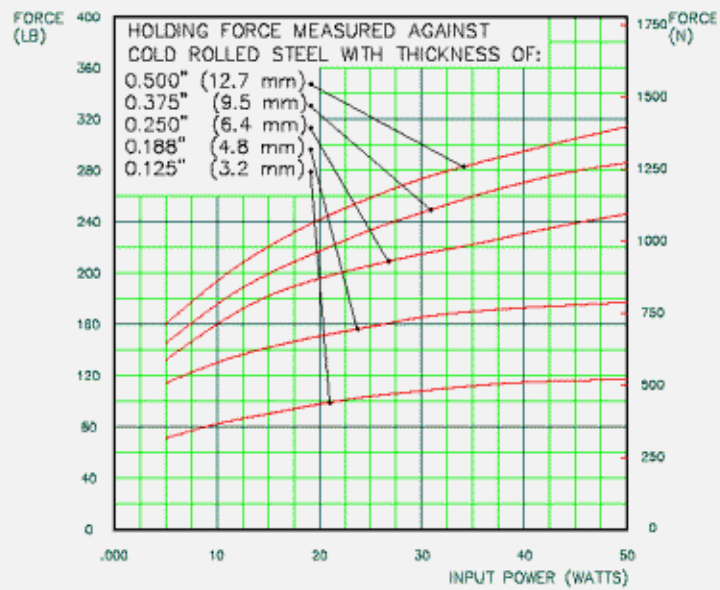

© Copyright 2002 Magnetic Sensor Systems

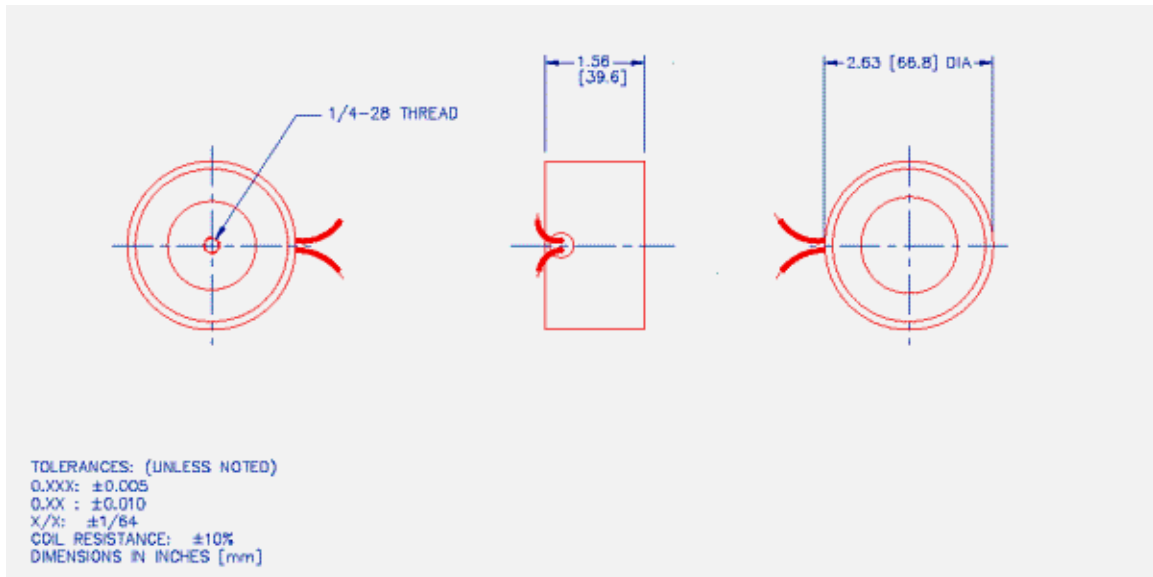

C = Continuous (100%) Duty Cycle, Maximum On-Time = Infinite
Approximate Input Power = 5 Watts

Holding force against cold rolled steel with a thickness of:

- 0.500" (12.7 mm): 144 Lb (65318 gr)
- 0.375" (9.5 mm): 131 Lb (59422 gr)
- 0.250" (6.4 mm): 119 Lb (53978 gr)
- 0.188" (4.8 mm): 103 Lb (46721 gr)
- 0.125" (3.2 mm): 64 Lb (29030 gr)

I = Intermittent (50%) Duty Cycle, Maximum On-Time = 2000 Seconds
Approximate Input Power = 10 Watts

Holding force against cold rolled steel with a thickness of:

- 0.500" (12.7 mm): 176 Lb (79834 gr)
- 0.375" (9.5 mm): 159 Lb (72122 gr)
- 0.250" (6.4 mm): 145 Lb (65772 gr)
- 0.188" (4.8 mm): 118 Lb (53525 gr)
- 0.125" (3.2 mm): 75 Lb (34020 gr)

L = Long Pulse (25%) Duty Cycle, Maximum On-Time = 600 Seconds
Approximate Input Power = 20 Watts

Holding force against cold rolled steel with a thickness of:

- 0.500" (12.7 mm): 218 Lb (98885 gr)
- 0.375" (9.5 mm): 195 Lb (88452 gr)
- 0.250" (6.4 mm): 176 Lb (79833 gr)
- 0.188" (4.8 mm): 136 Lb (61690 gr)
- 0.125" (3.2 mm): 88 Lb (39917 gr)

P = Pulse (10%) Duty Cycle, Maximum On-Time = 120 Seconds
Approximate Input Power = 50 Watts

Holding force against cold rolled steel with a thickness of:

- 0.500" (12.7 mm): 283 Lb (128369 gr)
- 0.375" (9.5 mm): 257 Lb (116575 gr)
- 0.250" (6.4 mm): 221 Lb (100246 gr)
- 0.188" (4.8 mm): 159 Lb (72122 gr)
- 0.125" (3.2 mm): 105 Lb (47628 gr)

Tubular Low Profile Electromagnet, 2.63" (67 mm) DIA X 1.56" (40 mm) L.
 Mounting: 1/4 -28 threaded hole.
 Minimum Heat Sink: Equivalent of 3.0" x 3.0" x 0.25" (76 mm x 76 mm x 6.4 mm) metal Plate
 All values are at 25°C.

Duty Cycle= on time/(on time+off time) in one cycle of operation when voltage is being cycled on and off.

$$V = R \times I$$

$$P = V \times I = V^2 / R = R \times I^2$$

V = input D.C. voltage (volts)
R = electromagnet resistance (ohms)
I = current used by electromagnet (amperes)
P = input power to electromagnet (watts)

Part 61: Motor Speed Controller

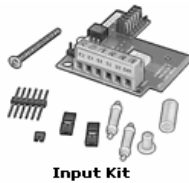

For hp	Output Voltage (VAC)	Input Voltage (VAC)	Ht. x Wd. x Dp.	
1/8- 1/2	230	115/230	3.0" x 4.3" x 3.7"	6488K21

McMASTER-CARR

Part 62: Input Kit for Motor Controller

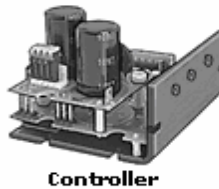

For hp	Output Voltage (VAC)	Input Voltage (VAC)	Ht. x Wd. x Dp.
1/8- 1/2	230	115/230	3.0" x 4.3" x 3.7"
1/4-1	230	115/230	4.5" x 6.9" x 4.4"
Input Kit			

McMASTER-CARR

Part 63: Motor Starter

Motor Starters with Overload Relay

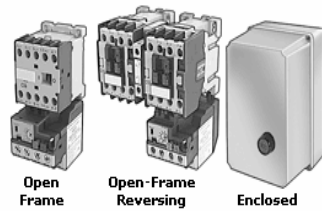

Adjustable Overload Amp Range	MAXIMUM MOTOR HORSEPOWER RATING, hp					Ht.	Wd.	Dp.	Open-Frame Starters		Enclosed Starters	
	Single Phase		Three Phase						Each	Each		
	115 VAC	230 VAC	200 VAC	230 VAC	460 VAC							
Standard— For Single- and Three-Phase Motors												
1.0-1.5					1/2- 3/4	4.3"	1.8"	3.2"	7603K56	134.04	7603K76	176.34
1.8-2.7			1/2	1/2	1	4.3"	1.8"	3.2"	7603K57	134.04	7603K77	176.34

McMASTER-CARR

Part 64: On/Off Power Cycler

Part # ELSOOPC950 Electric Load On-Off Power Cycling Module

From *electromechaniconline.com*

The Load On-Off Cycler is designed to enable the user to cycle the voltage across a solenoid or other devices. The frequency and the maximum voltage applied to the device are controlled using two onboard trim potentiometers. The range of the frequency is from 0.12 through 30 cycles per second.

Performance Specifications				
Parameter	Min	Typical	Max	Units
Supply Voltage	9		50	VDC
Peak Current			15	Amp
Average (RMS) Current		4		Amp
Cycling Frequency	0.12		30	Hz
Operating Temperature	0		50	Deg C
Heat Sink Temperature	0		75	Deg C
Storage Temperature	-40		125	Deg C
PWM Frequency		2		KHz

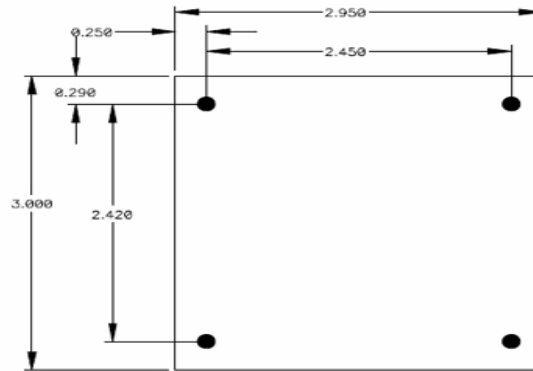

Electromechanics Inc.

Part 67: Bushings

Bronze Sleeve Bearings



Bearing Material	Temp. Range	Pmax	Vmax	PVmax
SAE 841	+10° to +220° F	2,000	1,200	50,000
Alloy 932 (SAE 660)	+10° to +450° F	4,000	750	75,000
SAE 863	+10° to +220° F	4,000	225	35,000
Alloy 954	Maximum is +500° F	4,500	225	125,000

SAE 841

Lg.	Each
-----	------

For Shaft Dia.: 3/8"; Bearing OD: 1/2"

1/4"	6391K171	.51
3/8"	6391K172	.58
1/2"	6391K173	.59
5/8"	6391K174	.76
3/4"	6391K176	1.34
7/8"	6391K175	1.02
1"	6391K178	.97

McMASTER-CARR

Appendix F

This page shows the calculation for the torque on the motor due to rotating the shaft, right grip and specimen.

Torque calculations/tests:

$$T = F \cdot d = m \cdot a \cdot d = \rho \cdot V \cdot a \cdot d$$

$$a := 32 \frac{\text{ft}}{\text{s}^2}$$

$$.25\text{in} = 0.021\text{ft}$$

$$.5\text{in} = 0.042\text{ft}$$

$$6\text{in} = 0.5\text{ft}$$

Weight Calculated on PrincipalMetal.com

$W_{9\text{inchshaft}} := 2.004\text{lb}$ Stainless steel 9inchx1inch diameter

$W_{3\text{inchshaft}} := .152\text{lb}$ Cast iron 3inchx.5inch diameter

$W_{6\text{inchshaft}} := 1.217\text{lb}$ Stainless steel 6inchx1inch diameter

f = "frictional force"

$$f = \mu \cdot N$$

$$f_9 = \mu \cdot W_{9\text{inchshaft}} \qquad f_6 = \mu \cdot W_{6\text{inchshaft}}$$

Torque not including Friction from bearings

$$T_{w9} := W_{9\text{inchshaft}} \cdot .042\text{ft}$$

$$T_{w9} = 0.012\text{m} \cdot \text{kg}$$

$$T_{w3} := W_{3\text{inchshaft}} \cdot .021\text{ft}$$

$$T_{w3} = 2.967 \times 10^{-4} \text{ m}^2 \frac{\text{lb}}{\text{ft}}$$

$$T_{w6} := W_{6\text{inchshaft}} \cdot .5\text{ft}$$

$$T_{w6} = 0.084\text{m} \cdot \text{kg}$$

Total Torque

$$T_{w9} + T_{w3} + T_{w6} = 0.096\text{m} \cdot \text{kg}$$

$$.096\text{m} \cdot \text{kg} = 0.694\text{ft} \cdot \text{lb}$$

Torque including Friction from bearings

$$T_{w9} = W_{9\text{inchshaft}} \cdot .042\text{ft} + 2f_9$$

$$T_{w3} := W_{3\text{inchshaft}} \cdot .021\text{ft}$$

$$T_{w3} = 4.416 \times 10^{-4} \text{ m} \cdot \text{kg}$$

$$T_{w6} = W_{6\text{inchshaft}} \cdot .5\text{ft} + 2 \cdot f_6$$

Total Torque

$$T_{w9} + T_{w3} + T_{w6}$$

In order to determine the torque caused by friction in the cold bearings, a test was performed using the main shaft, two pillow block mounted bearings, and a torque wrench (Figure F-1).



Figure F-1: Test Assembly

The test showed that the combination of two cold bearings resulted in less than 0.5 ft-lbs of torque. It is assumed that the flange mounted bearings will result in the same torque as the pillow block mounted bearings. Therefore, the additional torque due to friction in the four cold bearings is assumed to be less than 1ft-lb. The combined torque is then expected to be no greater than 1.7ft-lb.

Theoretical Force Calculations:

Stress calculations were performed in order to determine the necessary force according specimen dimensions and geometry. The .2 in. diameter specimen represents the smallest recommended specimen diameter recommended by ASTM. Similarly the 1 in. diameter represents the largest recommended diameter by ASTM. The .3 in. diameter represents the specimen diameter if the specimens for the combination fatigue tester.

Force Calculations

Gray Cast Iron Class 20

Force Needed to Reach Fatigue Limit (.3 in. Diameter)

$$f_{fl} := (.15\text{in})^2 \cdot \pi \cdot 1000\text{psi}$$

$$f_{fl} = 706.858\text{lbf}$$

Force Needed to Reach Fatigue Limit (.2 in. Diameter)

$$f_{fl\text{min}} := (.1\text{in})^2 \cdot \pi \cdot 1000\text{psi}$$

$$f_{fl\text{min}} = 314.159\text{lbf}$$

Force Needed to Reach Fatigue Limit (1 in. Diameter)

$$f_{fl\text{max}} := (.5\text{in})^2 \cdot \pi \cdot 1000\text{psi}$$

$$f_{fl\text{max}} = 7.854 \times 10^3 \text{lbf}$$

Force Needed to Reach Ultimate Tensile Strength (.3 in. Diameter)

$$f_{uts} := (.15\text{in})^2 \cdot \pi \cdot 2000\text{psi}$$

$$f_{uts} = 1.414 \times 10^3 \text{lbf}$$

Force Needed to Reach Ultimate Tensile Strength (.2 in. Diameter)

$$f_{uts\text{min}} := (.1\text{in})^2 \cdot \pi \cdot 2000\text{psi}$$

$$f_{uts\text{min}} = 628.319\text{lbf}$$

Force Needed to Reach Ultimate Tensile Strength (1 in. Diameter)

$$f_{uts\text{max}} := (.5\text{in})^2 \cdot \pi \cdot 2000\text{psi}$$

$$f_{uts\text{max}} = 1.571 \times 10^4 \text{lbf}$$

Force Calculations

Gray Cast Iron Class 30

Force Needed to Reach Fatigue Limit (.3 in. Diameter)

$$f_{30fl} := (.15\text{in})^2 \cdot \pi \cdot 1400\text{psi}$$

$$f_{30fl} = 989.602\text{bf}$$

Force Needed to Reach Fatigue Limit (.2 in. Diameter)

$$f_{30flmin} := (.1\text{in})^2 \cdot \pi \cdot 1400\text{psi}$$

$$f_{30flmin} = 439.823\text{bf}$$

Force Needed to Reach Fatigue Limit (1 in. Diameter)

$$f_{30flmax} := (.5\text{in})^2 \cdot \pi \cdot 1400\text{psi}$$

$$f_{30flmax} = 1.1 \times 10^4 \text{bf}$$

Force Needed to Reach Ultimate Tensile Strength (.3 in. Diameter)

$$f_{30uts} := (.15\text{in})^2 \cdot \pi \cdot 3000\text{psi}$$

$$f_{30uts} = 2.121 \times 10^3 \text{bf}$$

Force Needed to Reach Ultimate Tensile Strength (.2 in. Diameter)

$$f_{30utsmin} := (.1\text{in})^2 \cdot \pi \cdot 3000\text{psi}$$

$$f_{30utsmin} = 942.478\text{bf}$$

Force Needed to Reach Ultimate Tensile Strength (1 in. Diameter)

$$f_{30utsmax} := (.5\text{in})^2 \cdot \pi \cdot 3000\text{psi}$$

$$f_{30utsmax} = 2.356 \times 10^4 \text{bf}$$

Shear force calculations (bolts):

These calculations are for part #53. Their position can be seen in Subassembly G (Appendix D). For the purposes of this test, a worst case scenario is assumed where the maximum load is assumed to be acting entirely on a single bolt.

Shear Calculations For Force On One Bolts

7/16 inch Bolt

Diameter: $d_1 := \left(\frac{7}{16}\right)\text{in}$

Radius: $r_1 := \frac{d_1}{2}$

Area: $A = \pi \cdot r^2$

$\tau =$ "Shear stress"

$$\tau = \frac{F}{A}$$

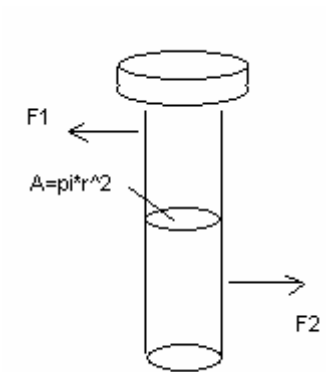

Force will vary from 100lb max force to 10lb minimum force

$$F_1 = F_2$$

$$F_1 := 0\text{lb}, 10\text{lb}.. 100\text{lb}$$

$$F_2 := 0\text{lb}, 10\text{lb}.. 100\text{lb}$$

Area => $A_1 := \pi \cdot r_1^2$

$$\tau_1(F_1) =$$

0	$\frac{\text{lb}}{\text{in}^2}$
66.52	
133.041	
199.561	
266.081	
332.601	
399.122	
465.642	
532.162	
598.682	
665.203	

Force verse Shear Stress graph

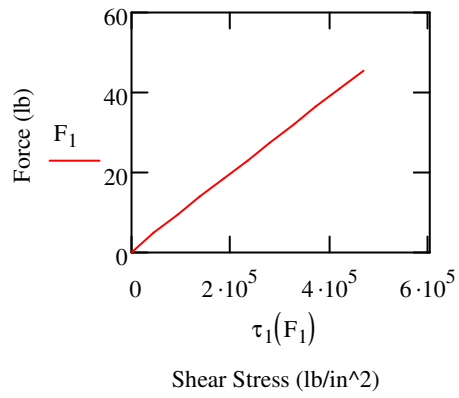

The following are calculation for the shear stress of part #39. Their position can be seen in Subassembly D. For the purposes of this test, a worst case scenario is assumed where the maximum load is assumed to be acting entirely on a single bolt.

¼ inch Bolt

Diameter: $d_2 := \left(\frac{1}{4}\right)\text{in}$

Radius: $r_2 := \frac{d_2}{2}$

Force will vary from 100lb max force to 10lb minimum force

$$F_1 = F_2$$

$$F_1 := 0\text{lb}, 10\text{lb}.. 100\text{lb}$$

$$F_2 := 0\text{lb}, 10\text{lb}.. 100\text{lb}$$

Area => $A_2 := \pi \cdot r_2^2$

Shear Stress=> $\tau_2(F_1) := \frac{F_1}{A_2}$

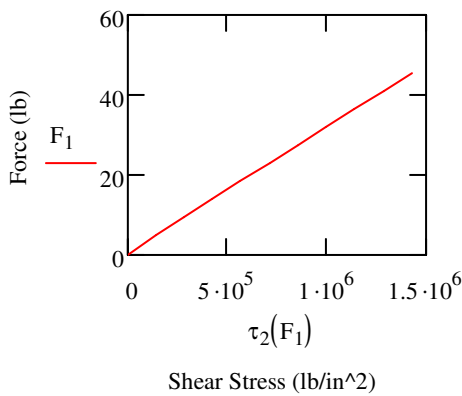

$\tau_2(F_1) =$

0
203.718
407.437
611.155
814.873
1.019·10 ³
1.222·10 ³
1.426·10 ³
1.63·10 ³
1.833·10 ³
2.037·10 ³

$\frac{\text{lb}}{\text{in}^2}$

Electromagnet Temperature at different Operating Conditions:

Below are the results for a test conducted to determine how quickly the electromagnets heat up at different input powers. The temperatures were measured using an infrared thermometer. The ambient temperature was measured off of the steel plate used to repel the electromagnet. The conditions were: quiescent air, continuous duty cycle, no fin. A plot of the temperature profile can be seen in Figure F-2.

Electromagnet 1 has a measured resistance of 18.7 ohms and it is running off a 19.2V power source. There is 19.7W of power going into electromagnet 1. Electromagnet 2 has a measured resistance of 19.0 ohms and it is running on a 12.4V power source. There is 8.1W of power going into electromagnet 2.

	Electromagnet 1		Electromagnet 2
Time (min)	Temperature (deg. F)	Temperature (ambient) (deg. F)	Temperature (deg. F)
0	72.8	71.7	73.2
5	76.4	73.6	75.6
10	81	74.3	77.2
15	91.8	74.9	83
20	95.6	75.4	84
25	105	75.8	87.5

Table F-1: Electromagnet Temperature Data

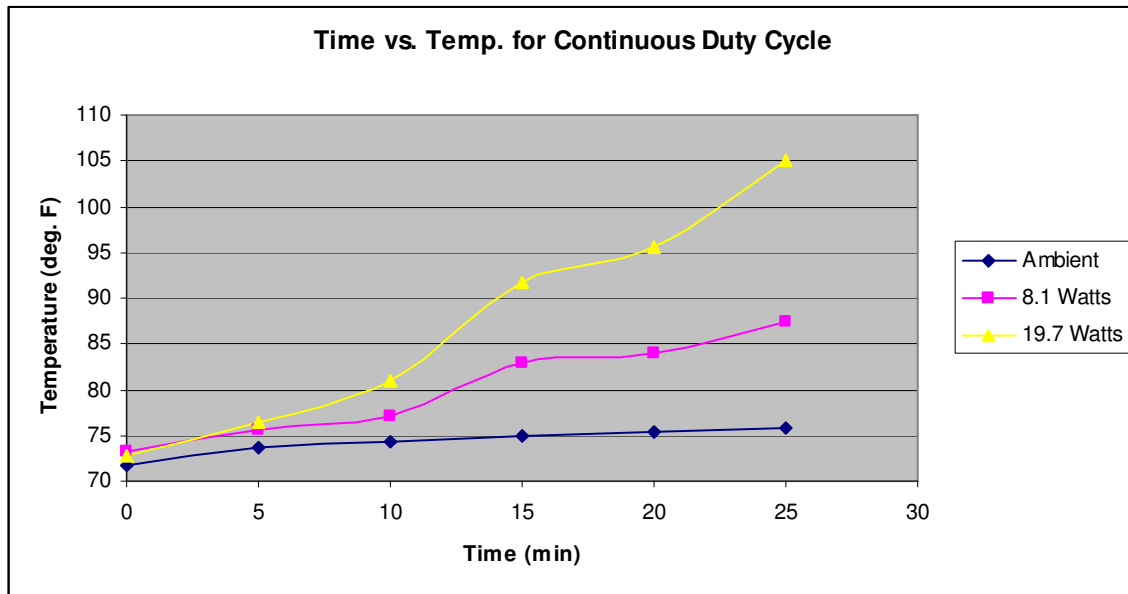

Figure F-2

Clearly, the temperature is rising much more rapidly at the higher wattage. The temperature needs to level off during regular operation so that the magnets are not damaged.

Expected Tensile load needed for a given elongation of specimen:

ΔL = "Change in specimen length" = "Axial elongation of Specimen"

ϵ = Strain

σ = "Normal Stress"

P = Load

A = "Cross Section Area"

E := "Modulus of elasticity"

ν = "Poisson s Ratio"

$$M := 10^6$$

$$k := 10^3$$

Class 20 Cast Iron

Properties found at

<http://www.matweb.com/search/SpecificMaterial.asp?bassnum=MCFE10>

Assuming lowest value of Elastic Modulus

$$E := 9750 \cdot k \cdot \text{psi}$$

$$\nu := .25$$

$$L := 3 \text{in}$$

$$r := .25 \text{in}$$

$$L = 0.076 \text{m}$$

$$r = 6.35 \times 10^{-3} \text{m}$$

$$\Delta L := \left(\frac{3}{10000} \right) \text{in}$$

$$\Delta L = 7.62 \times 10^{-6} \text{m}$$

$$\epsilon := \frac{\Delta L}{L}$$

$$\epsilon = 1 \times 10^{-4}$$

$$\sigma := E \cdot \epsilon$$

$$\sigma = 975 \text{psi}$$

$$A := \pi r^2$$

$$A = 0.196 \text{in}^2$$

$$P := \sigma \cdot A$$

$$P = 191.44 \text{lbf}$$

Required magnetic pushing force calculations

Estimated acceleration of the platform.

$$m_p := 20\text{lb} \quad \text{Assumed mass of platform}$$

$$d_p := 0.0003\text{in} \quad \text{Displacement of platform}$$

$$t := \frac{1}{60}\text{s}$$

At 30 cycles/second, it would need to travel 0.0003in in 1/60th of a second.

$$v_{\text{avg}} := \frac{d_p}{t} \quad v_{\text{avg}} = 4.572 \times 10^{-4} \frac{\text{m}}{\text{s}}$$

$$v_{\text{max}} := 2 \cdot v_{\text{avg}}$$

$$a_p := \frac{v_{\text{max}}}{\frac{1}{60}\text{s}} \quad \text{Acceleration needed for platform}$$

$$a_p = 0.055 \frac{\text{m}}{\text{s}^2}$$

$$F_m := m_p \cdot a_p \quad \text{Combined force required to move platform} \quad F_m = 0.112\text{lb}$$

Electromagnet calculations for power consumption.

$R_{e1} := 19.1$ Resistance of electromagnet #1 in Ω . This was tested using a multimeter.

$R_{e2} := 17.4$ Resistance of electromagnet #2 in Ω

$V := 12.4$ Input voltage in volts

$$R_{eq} := \left(\frac{1}{R_{e1}} + \frac{1}{R_{e2}} \right)^{-1} \quad R_{eq} = 9.105 \quad \Omega \quad \text{Equivalent resistance of the two electromagnets in parallel.}$$

Now find the total current:

$$I := \frac{V}{R_{eq}} \quad I = 1.362 \quad \text{amps} \quad \text{Current}$$

Power consumed by both magnets combined:

$$P := \frac{V^2}{R_{eq}} \quad P = 16.887 \quad \text{watts}$$

In the final assembly, electromagnet #1 is used.

Power consumed at 12.4 VDC:

$$P := \frac{V^2}{R_{e1}} \quad P = 8.05 \quad \text{Watts}$$

Power consumed at 19.4 VDC:

$$V := 19.4$$

$$P := \frac{V^2}{R_{e1}} \quad P = 19.705 \quad \text{Watts}$$

Algor Calculations:

Finite element analysis was performed on the specimen for several reasons. It was first needed to be confirmed that the maximum stresses were occurring at the center of the specimen. Also needed was the maximum displacement the specimen would see. All analysis was performed with a simulated specimen of class 30 gray cast iron. The specimen had a test diameter of .3 in.

Figure F-3 shows that the maximum stress when a surface load is applied at one end of the specimen. This simulates the maximum bending load, based on the ultimate tensile strength that would be experienced by the specimen during testing. Figure F-4 shows that the specimen will displace a maximum of .03 in. in the z-direction (vertically for the sake of a real test) before failing.

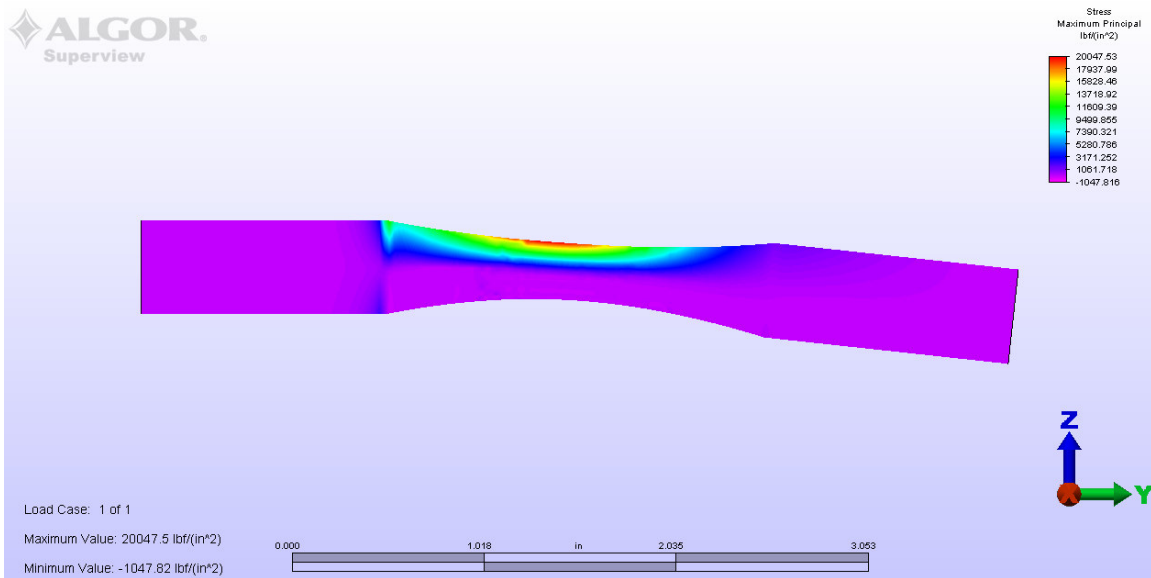

Figure F-3: Maximum Principal Stress with a 30lbf load applied to right side of specimen

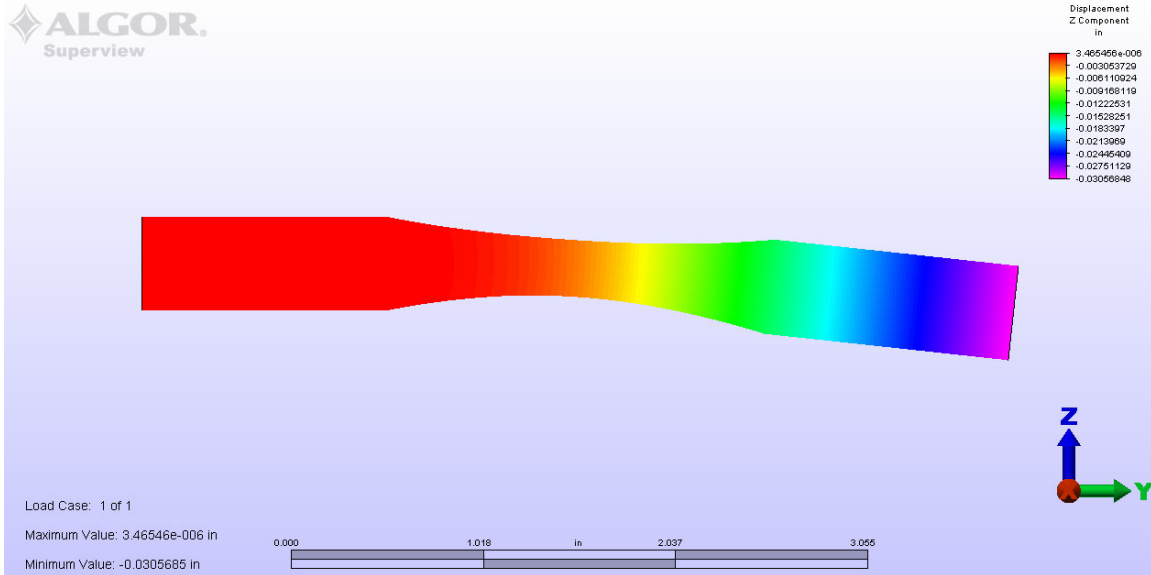

Figure F-4: Vertical Displacement a 30lb load applied to right side of specimen

Figure F-5 displays the reactions of the specimen when under going a tensile load. Again it was confirmed that the maximum stresses would occur in the desired region. Figure F-6 displays a maximum displacement of .004 in. when the ultimate tensile load is experienced. The data obtained from the finite element analysis was used for many calculations.

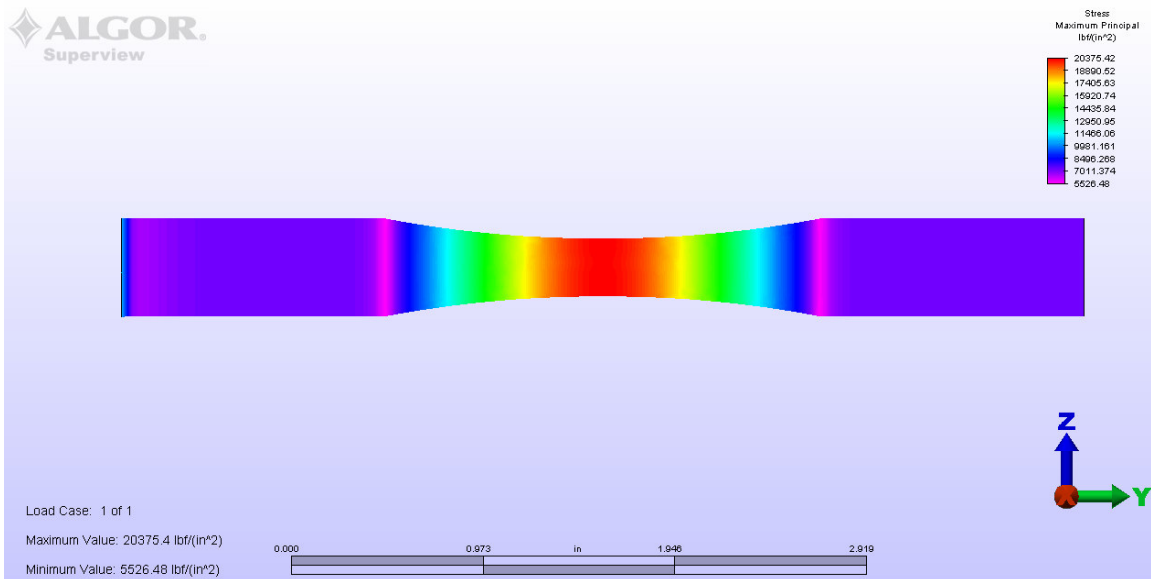

Figure F-5: Maximum Principal Stress under a 30lb tensile load

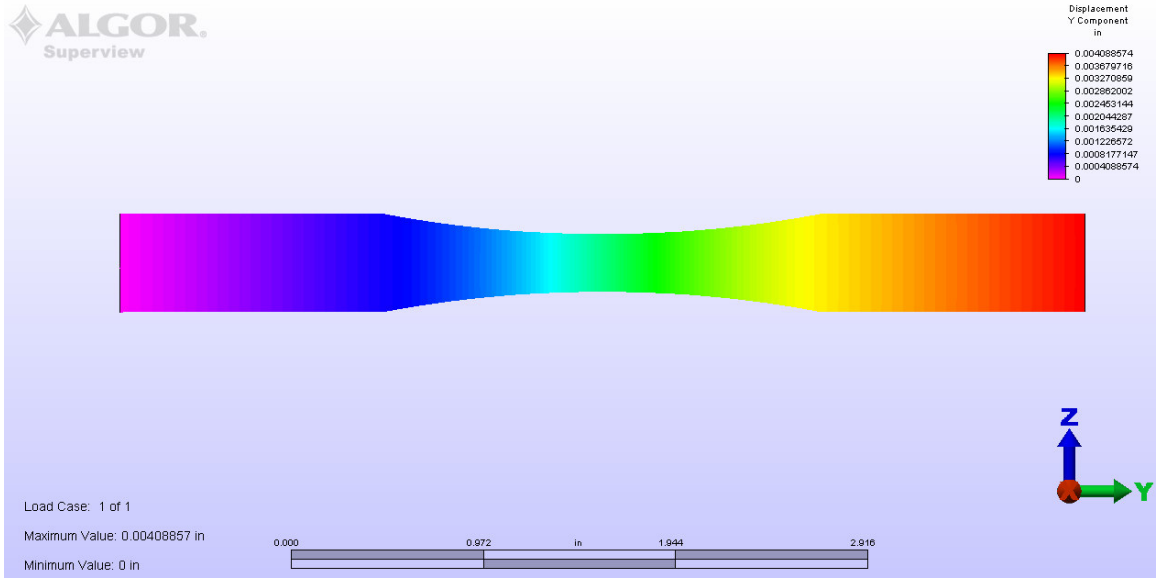

Figure F-6: Horizontal Displacement under a 30lb tensile load

Appendix G

Part Masses:

Machine Part	Mass (g) Tolerance (+/- 2g)	Mass (lbs) Tolerance (+/- .01)
Right mounted support	665	1.47
left mounted support	665	1.47
small spacer	1354	2.99
rear support	1550	3.42
vertical track (1 dot)	356	0.78
vertical track (2 dot)	358	0.79
vertical support (2 dot)	96	0.21
vertical support (1 dot)	96	0.21
vertical track guide (blue)	34	0.07
vertical track guide (silver)	34	0.07
linear bearing mount (1 dot)	545	1.20
linear bearing mount (2 dot)	523	1.15
platform connector	339	0.75
vertical load cell mount top	513	1.13
Pivot plate	528	1.16
flange mount bearing (bottom sticker)	733	1.62
flange mount bearing (top sticker)	727	1.60
Top bar	231	0.51
Pivot pin (1 dot)	36	0.08
Pivot pin (2 dot)	36	0.08
spider coupling hub 5/8in	277	0.61
spider coupling hub 1in	241	0.53
spider	12	0.03
vertical guide rod	83	0.18
pillow block bearing (writing)	736	1.62
pillow block bearing (no writing)	733	1.62
main shaft	846	1.87
right grip	548	1.21
linear shaft mounts	104	0.23
1 in bolt	445	0.98
7/16-20 bolt	54	0.12
7/16-20 nuts	11	0.02
7/16-20 big bolt	82	0.18
specimen	71	0.16
electromagnet	866	1.91
3/4-16 nut	32	0.07
Specimen Blank	102	0.22
1/4 long bolt	32	0.07
linear bearings	109	0.24
Load cell	17	0.04
bushings		0.00
1/4-28 fully threaded 2in	12	0.03
Base		67.00
large spacer		11.20

Appendix H



Cummins 2



Fatigue Tester Operations Manual

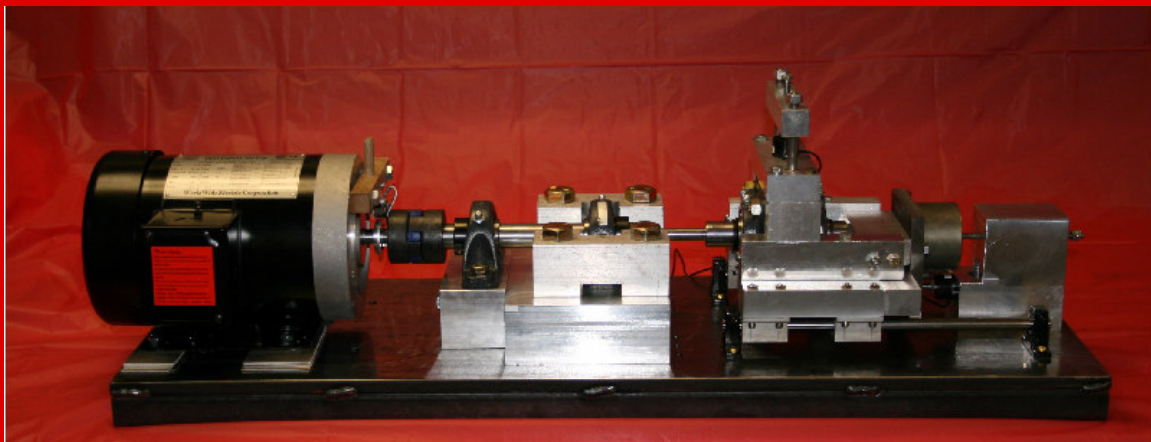

Department of Mechanical Engineering
EML 4551 Senior Design Project
Dr. Cesar Luongo

Team 11

Members:

Robert Graves
Coby W. McColgin
Robert Nichols II
Brett Van Hazel

Graduate Assistant: Kevin Garvey

Purpose

The purpose of the CL-12 is to perform Rotating Bending Fatigue (RBF) Testing, Tensile Fatigue Testing, and/or a combination of the two in order to produce data that can be used to predict trends in metals.

Safety Precautions

1. Safety goggles should be worn during machine operation.
2. Check CL-12 for loose or damaged nuts and bolts. Tighten all loose nuts and bolts and replace any damaged nuts and bolts (reference Appendix A).
3. Make sure the CL-12 is on a level sturdy surface before testing.
4. Place safety box over CL-12 before testing begins, and keep the box over the CL-12 during all testing.
5. Make sure power outlet being used can safely handle the electrical components of the CL-12.
6. Relubricate bearings 2 times per year

Test Procedure

How to run a test

Tensile loading only:

Step 1)

Begin by making sure that everything is turned off. Adjust the vertical loading bolt so that the right grip and the main shaft are aligned.



Step 2)

Using the spacer plate, adjust the tensile loading bolt or the magnet adjustment screw so that the electromagnet is a set distance from the steel plate. Be sure not to tangle the power chord. Note that the tensile loading bolt must always be flush with the load cell when running a test.

Note: Counter Clockwise Extends Electromagnet

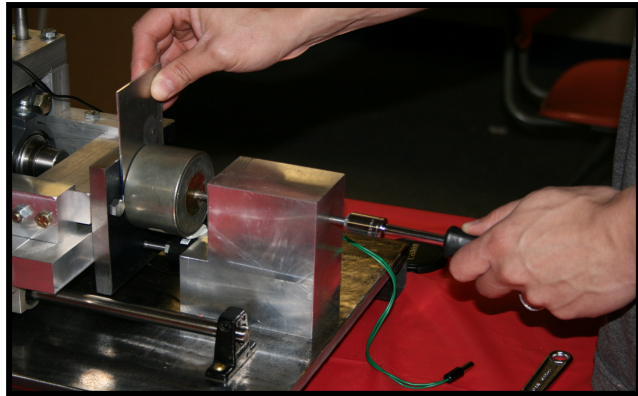

Step 3)

Start Labview in accordance with attached instructions.

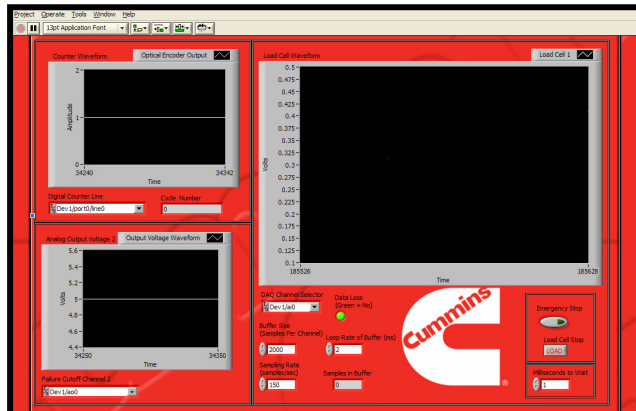

Step 4)

Plug in the electromagnet power supply and adjust the power cycler to the lowest frequency setting.

Note: Counter Clockwise Decreases Frequency.

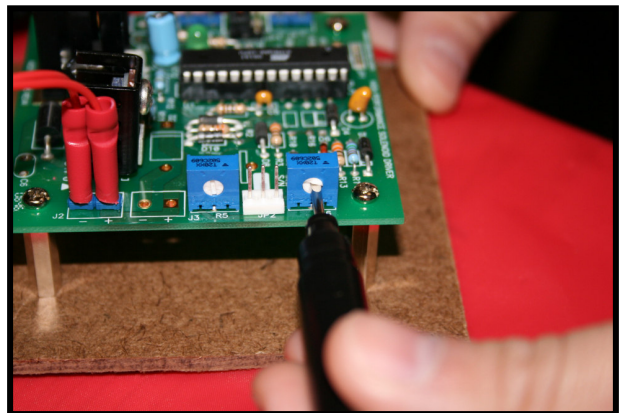
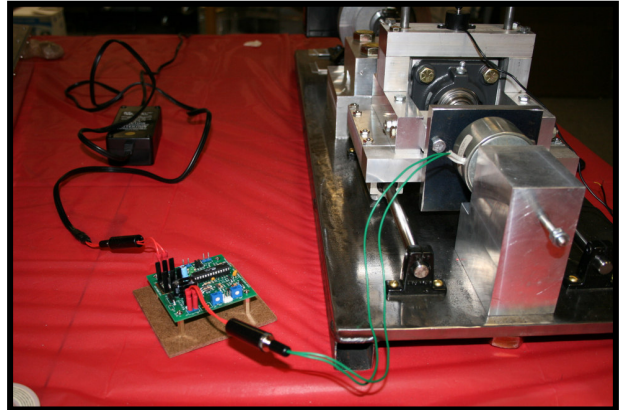

Step 5)

Using Labview, record the magnitude of the force (or voltage, from which force can be calculated) being applied to the load cell. This is for calibration purposes.

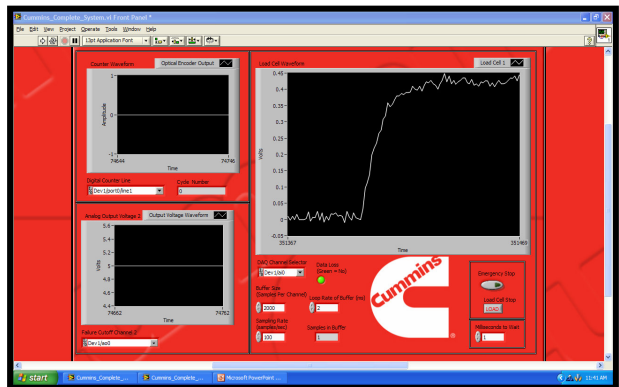

Step 6)

Unplug the electromagnet power supply. Retract the electromagnet and tensile load bolt.

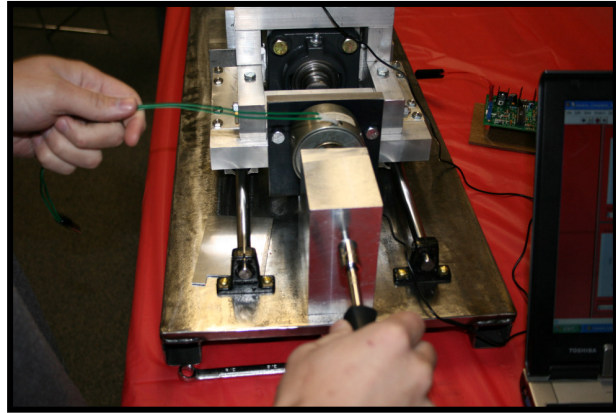

Step 7)

Tilt the right grip so that the opening is facing up. Insert the specimen into the right grip and turn clockwise to tighten. Lower the right grip and align the specimen with the opening in the end of the main shaft. It may be necessary to remove the rear steel plate in order to insert or remove specimens.

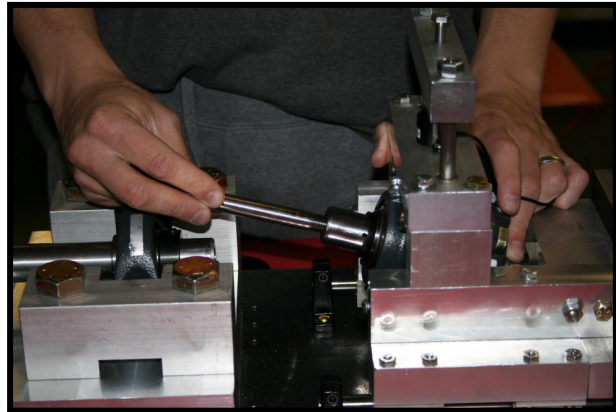
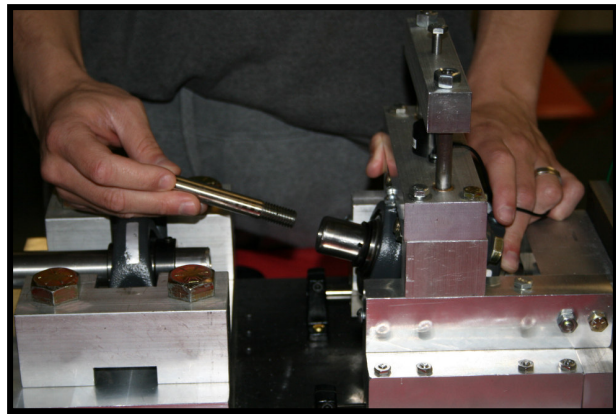

Step 8)

Move the platform so that the specimen is inserted into the main shaft. Rotate the main shaft so that the specimen is threaded into the shaft and tightened.

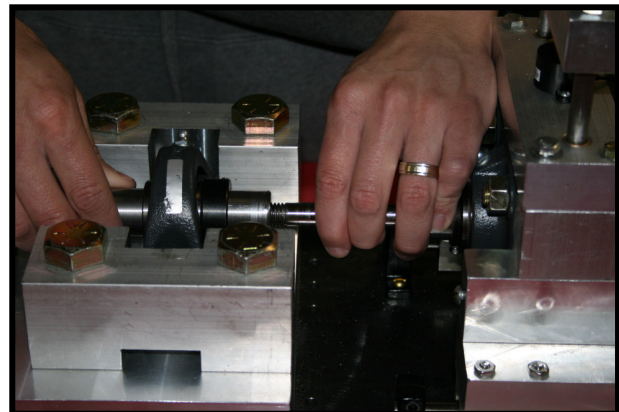

Step 9)

Adjust the electromagnet and/or tensile loading bolt so that the electromagnet face is the same distance from the steel plate as it was during the calibration stage (again, use the spacer plate). Plug the electromagnet power supply back in and read the loading that is recorded by Labview. The difference between the reading taken before the specimen was loaded and this reading is the load being applied to the specimen. Start a new “test” in Labview and adjust to the desired frequency of the electromagnet cycle using the right-most trim potentiometer on the On/Off Power Cycler. Be sure to keep the frequency low enough that the sensor and software can distinguish between cycles.

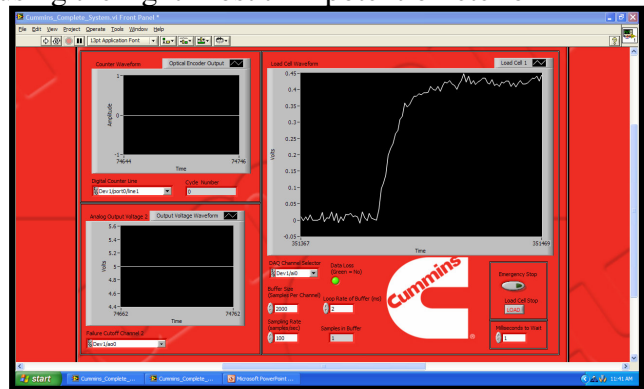
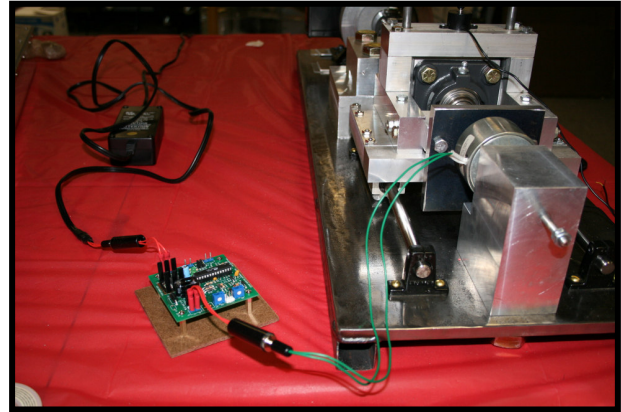

Testing Complete

Once the test is completed, unplug the electromagnet power supply. Then remove the specimen (or specimen fragments) from the main shaft and right grip.

Rotating-bending only:

Step 1)

To perform the Rotating-Bending test, begin by making sure that everything is turned off. Adjust the vertical loading bolt so that the right grip and the main shaft are aligned.

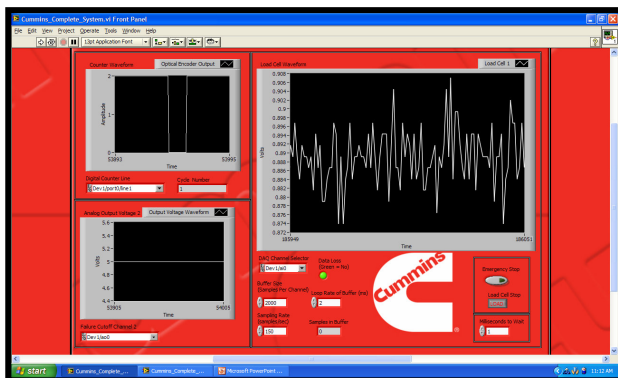
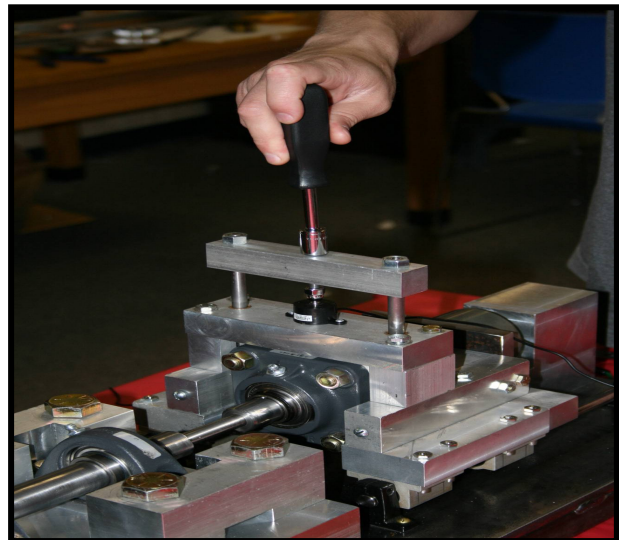

Step 2)

Follow **Step 7** of tensile loading instructions.

Step 3)

Plug in the motor. Start the motor using Labview, and increase to top speed for two minutes. This is to allow the bearing lubrication to warm up. Remove the specimen blank and replace it with a specimen, following the same procedure as before. Note: it may be necessary to remove the rear steel plate in order to insert or remove specimens and specimen blank.

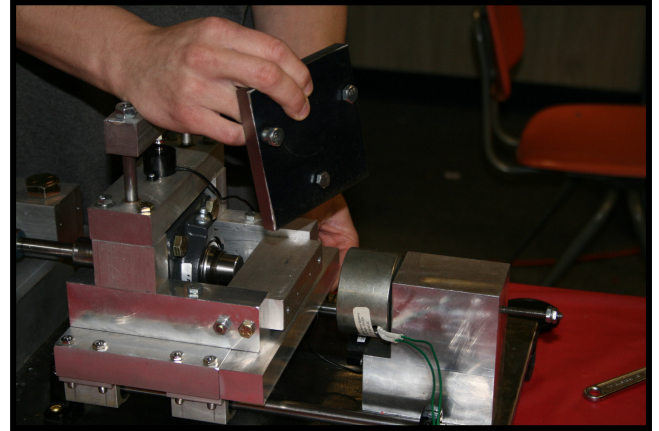

Step 4)

Check to make sure that the vertical load is the same as it was with no specimen. Adjust the vertical load bolt in order to increase the vertical load (the difference between the no-specimen load and this reading is the actual bending load being applied to the specimen). Restart the data acquisition in Labview and plug in the motor.

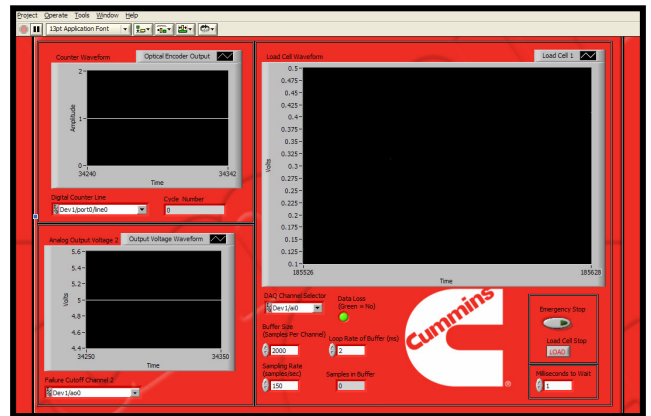

Testing Complete

Allow the test to run until failure or until the desired number of cycles has been reached. Unplug the motor and remove the safety box. Then remove the specimen (or specimen fragments) from the main shaft and right grip.

Combined loading (tensile and rotating-bending):

Follow the procedures for each mode, making sure to use the specimen black to warm up the bearings first.

**Cummins Inc. RBF Test Rig
Data Acquisition and Control System
User's Guide**



**Created By: Kevin Garvey
Date: March 29, 2007**

Introduction

This manual outlines the proper setup and usage of the NI USB-6009 DAQ board and the associated LabVIEW virtual instrument (VI) software designed specifically for use with the Cummins Inc. RBF test rig.



Safety Instructions



DO NOT connect the USB-6009 to the USB Hub on the computer interface until all sensors have been connected to the USB-6009 and checked for correct orientation.

The USB-6009 outputs **5 Volts DC at 8.5 mA** max. Take precaution when connecting and disconnecting wires.

USB-6009 DAQ Board Channel Configuration

The following diagrams outline the specific channel lines and their accompanying LabVIEW program reference title.

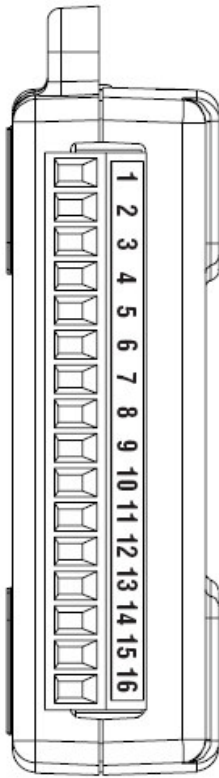

Channel	Reference	LabVIEW Channel Reference
1	Ground	N/A
2	Analog Input	AI 0
3	Analog Input	AI 4
4	Ground	N/A
5	Analog Input	AI 1
6	Analog Input	AI 5
7	Ground	N/A
8	Analog Input	AI 2
9	Analog Input	AI 6
10	Ground	N/A
11	Analog Input	AI 3
12	Analog Input	AI 7
13	Ground	N/A
14	Analog Output	AO 0
15	Analog Output	AO 1
16	Ground	N/A

Figure 1: USB-6009 Analog Channels

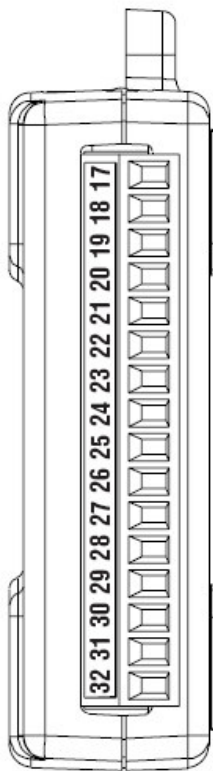

Channel	Reference	LabVIEW Channel Reference
17	Digital Port/Line	P0.0
18	Digital Port/Line	P0.1
19	Digital Port/Line	P0.2
20	Digital Port/Line	P0.3
21	Digital Port/Line	P0.4
22	Digital Port/Line	P0.5
23	Digital Port/Line	P0.6
24	Digital Port/Line	P0.7
25	Digital Port/Line	P1.0
26	Digital Port/Line	P1.1
27	Digital Port/Line	P1.2
28	Digital Port/Line	P1.3
29	Counter Input	PFI0
30	+2.5VDC	N/A
31	+ 5VDC	N/A
32	Ground	N/A

Figure 2: USB-6009 Digital Channels

Connecting sensors to the USB-6009 DAQ Board

Various sensors may be connected to the USB-6009 DAQ board. The RBF test rig only requires the connection of 2 Load Cells, 1 Optical Encoder, and 1 Electromechanical Relay. Below is the procedure for connecting these sensors to the board.

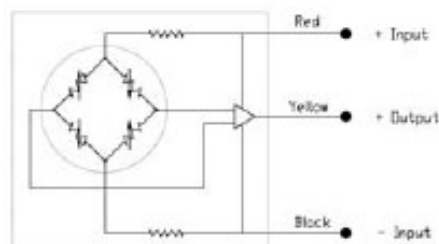

Figure 3: Load Cell Schematic (FC22 Type)

- Load Cell Connection
 1. Connect Red Power Wire to Port 31 (See figure 3 above)
 2. Connect Yellow Signal Wire to Analog Port 2

3. Connect Black Ground Wire to port 32

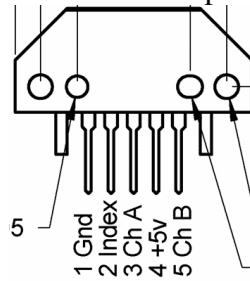

Figure 4: Optical Encoder Schematic (HEDS Type)

- HEDS Optical Encoder Connection
 1. Connect +5V to Port 31 (See figure 4 above)
 2. Connect Index to 17 and 29 in parallel
 3. Connect Gnd to Port 32

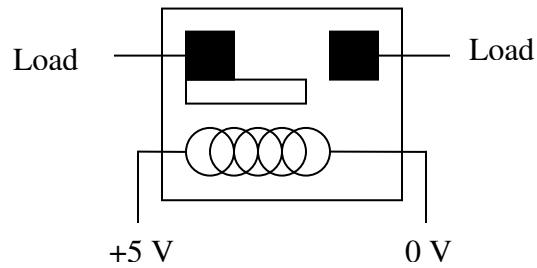

Figure 5: Relay Schematic (Reed Type)

- Reed Relay Cutoff Circuit Connection
 1. Connect +5V to Port 31 (See figure 5 above)
 2. Connect Load in series across motor power wire
 3. Connect 0V to Port 32

Important Note:

After connecting all sensors, ensure that all channels are properly connected and that no short circuits are present. Before connecting the USB-6009 to the computer,

check to make sure that no wires will bind or become pinched by the RBF test rig during the testing process.

LabVIEW Virtual Instrument Software

- Ensure that all electrical sensors are correctly oriented and connected into the USB-6009 DAQ board.
- Connect the DAQ board to the USB hub into the computer interface.
- Finally, turn on computer and open the LabVIEW VI program titled **Cummins Complete System.vi**

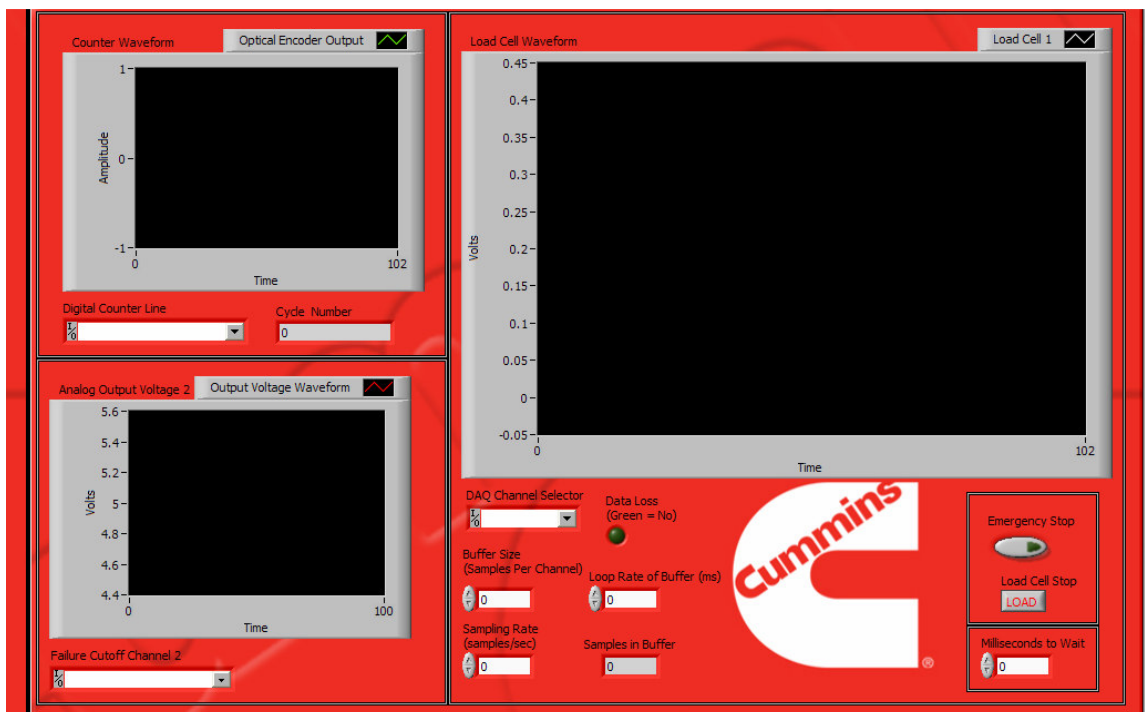

Figure 6: LabVIEW VI Screenshot

Program Description

- Counter Waveform (Upper Left Box)
 - The upper left box of the program shows the cycle count number and the associated waveform from the optical encoder.
- Cutoff Channel Waveform (Lower Left Box)
 - The lower left box outlines the waveform from the analog output signal. This channel outputs a constant 5 Volts DC when no failure is present and outputs 0 Volts when a failure occurs.

- Load Cell Waveform (Right Box)
 - The right box shows the load cell waveform which outputs the load signals from the associated channels.
- Emergency Cutoff Circuit (Lower Right Box)
 - The lower right box contains the emergency stop button for emergency cutoff of the entire RBF system as well as the LabVIEW program.
 - This circuit also contains an option to connect/disconnect certain load cell channels during a test.

Running the LabVIEW Virtual Instrument Software

To run the Cummins Inc. LabVIEW VI program, the following steps need to be followed before starting the program.

Assigning Channels:

- 1.) Pull down the drop down menu in the counter waveform box and select Dev1/port0/line0 (as seen in figure 7 below)
- 2.) Pull down the drop down menu in the analog output box and select Dev1/ao0
- 3.) Pull down the drop down menu in the load cell box and select Dev1/ai0

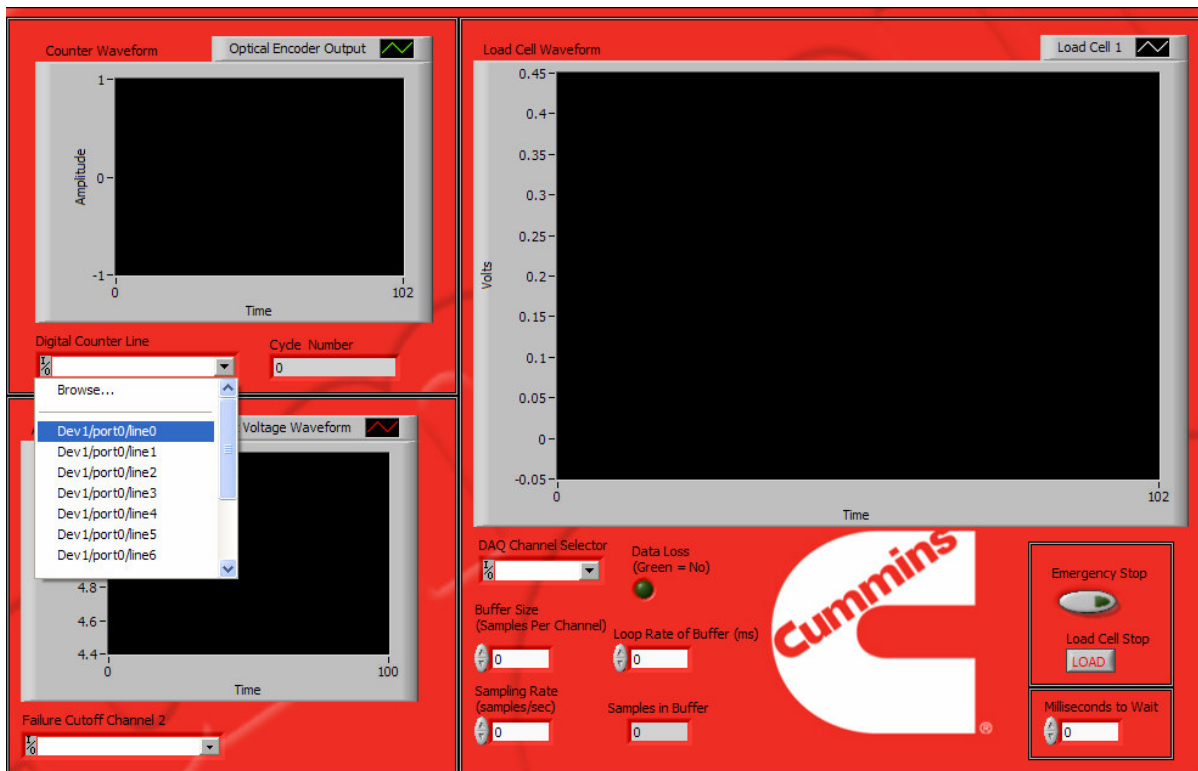

Figure 7: Assigning Channels in LabVIEW VI

Setting the Buffer configuration:

A buffer has been setup within the LabVIEW VI such that the sample rate can be set so the USB-6009 DAQ Board will not become over saturated and begin to lose data. To set the buffer the following steps need to be followed:

- 1.) Under the “Buffer Size,” set the samples per channel, at the most, to 2000.
- 2.) Under “Sampling Rate,” set the samples/sec to 150 at the most.
- 3.) Under “Loop Rate of Buffer,” set the ms to 2 at the most.
- 4.) Also, set the “Milliseconds to Wait” to 1. (Reference figure 8 below)

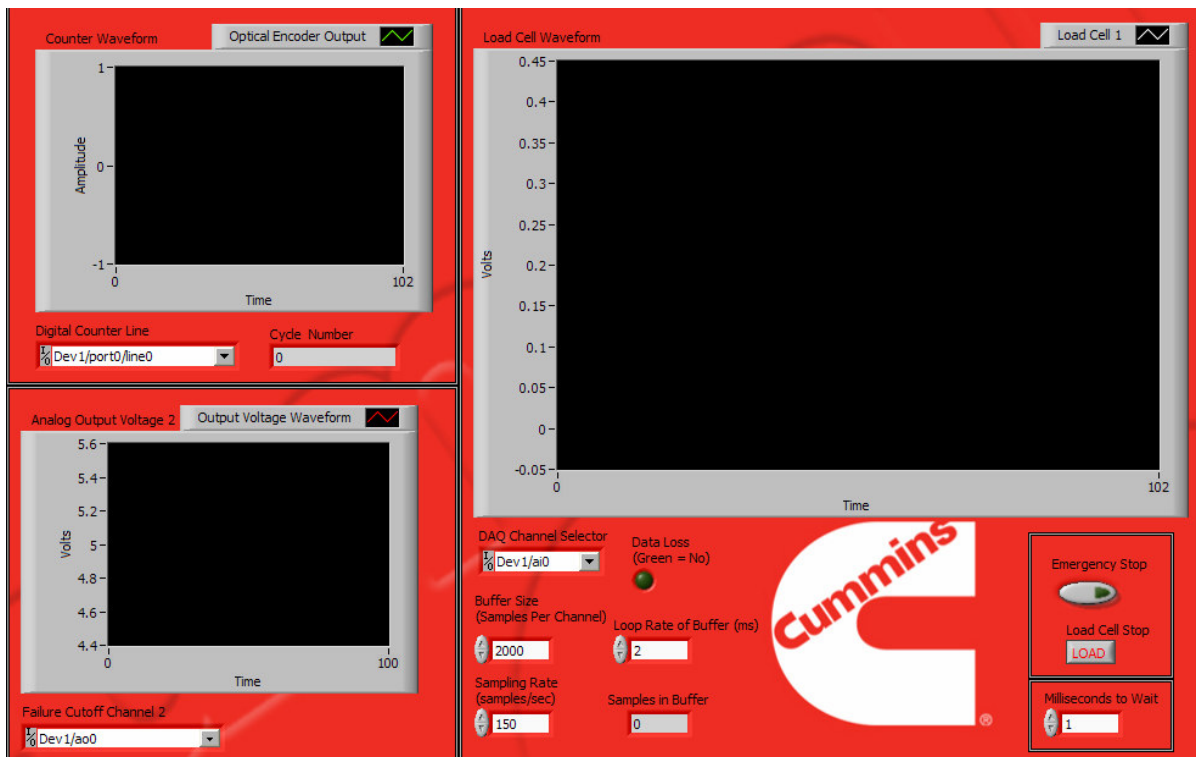

Figure 8: Buffer Configuration

Important Note:

The buffer has a circuit which constantly checks against data loss. A **GREEN** indicator light means that NO data is being lost. If the indicator light is off, then data loss is occurring and the sampling rate needs to be decreased. The USB-6009 DAQ board has a 32 bit internal buffer that is constantly overwritten by this software buffer. If at any time during the testing a 32 appears in the “Samples in Buffer” box, then data is being aliased into the real-time display and the test data is compromised.

Running the VI and Emergency Cutoff Circuits:

There are 2 modes that the VI can be configured for: Simple Run or Continuously Run.

- 1.) First choose Simple Run as seen in figure 9 below.
- 2.) Once the program begins running and no errors have been found, then the Continuously Run option should be selected. (See Figure 9 below)

Emergency Stop Cutoff

If for any reason the system needs to be cutoff from a remote distance from the RBF test rig, an emergency stop cutoff circuit has been added for safety. See figure 9 below for the location of the emergency stop cutoff button.

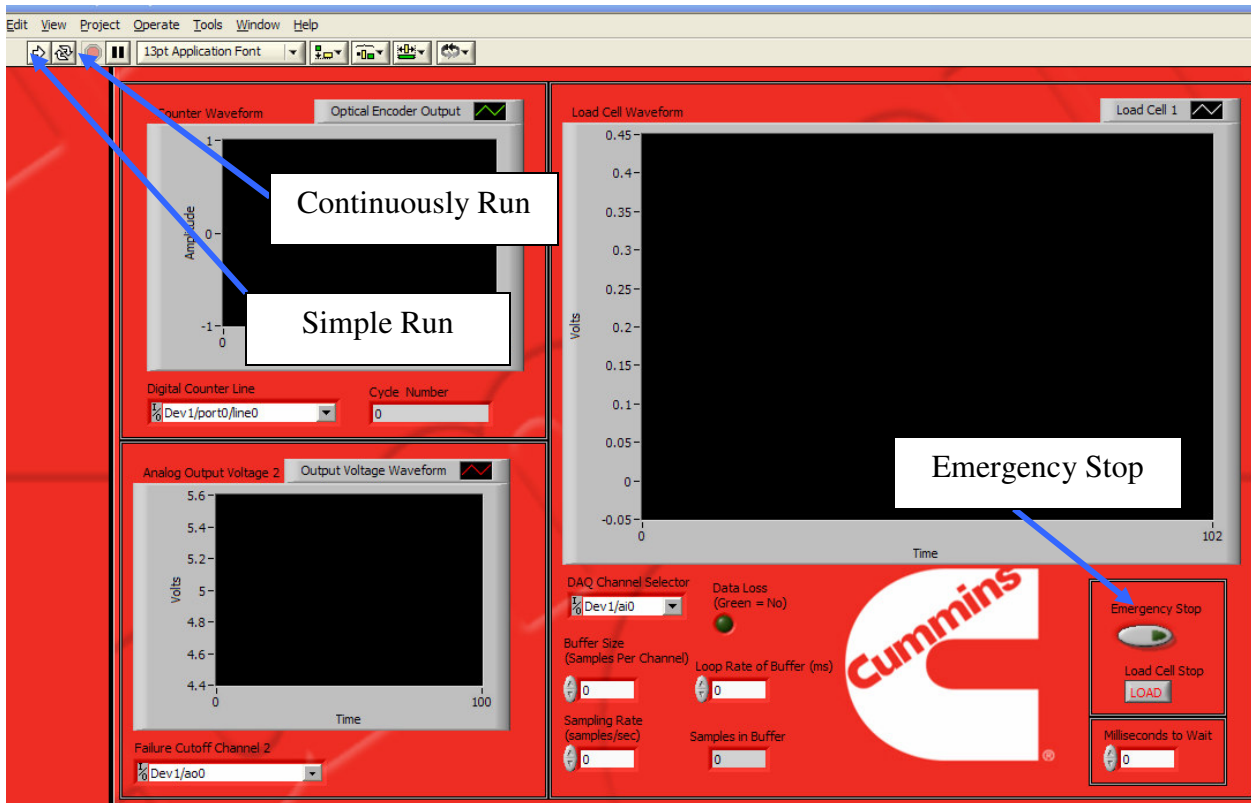

Figure 9: Run Modes and Emergency Cutoff

Bibliography:

1.) Background Information –

- a. www.epi-eng.com/BAS-Fatigue.htm
- b. www.instron.us/wa/applications/test_types
- c. www.coiledtubingtulsa.org
- d. www.wikipedia.org
- e. www.hyperphysics.phy-astr.gsu.edu/hbase/magnetic/solenoid.html#c3
- f. www.ee.surrey.ac.uk/Workshop/advice/coils/force.html
- g. Norton, R. *Machine Design, An Integrated Approach*, 3rd ed. Upper Saddle River, NJ. Pearson Education, Inc. 2006.
- h. ASTM Standard - Designation: E 739 - 91. *Standard Practice for Statistical Analysis of Linear or Linearized Stress-Life (S-N) and Strain-Life (ϵ -N) Fatigue Data.*
- i. ASTM Standard - Designation: E 206 - 72. *Standard Definitions of Terms Relating to FATIGUE TESTING AND THE STATISTICAL ANALYSIS OF FATIGUE DATA.*
- j. ASTM Standard - Designation: E 466 - 82. *Standard Practice for Conducting constant Amplitude Axial Fatigue Tests of Metallic Materials.*
- k. ASTM Standard - Designation: E 467 – 98a. *Standard Practice for Verification of Constant Amplitude Dynamic Forces in an Axial Fatigue Testing System.*

2.) Analysis Information –

- a. Smith, W.F., and J. Hashemi, Ph.D. 2006. *Foundations of Materials Science and Engineering*, 4th ed. New York, NY. McGraw-Hill, Inc.
- b. Weibull, W. *Fatigue Testing and Analysis of Results*. New York, NY. Pergamon Press, 1961.
- c. Hibbeler, R.C. *Statics and Mechanics of Materials*, 2nd ed. Upper saddle River, NJ. Person Education, Inc. 2004
- d. Bannantine, J., Ph.D., J. Comer, Ph.D., and J. Handrock, Ph.D. 1990. *Fundamentals of Metal Fatigue Analysis*. Englewood Cliffs, NJ. Prentice-Hall, Inc. 1990.

3.) Parts Suppliers –

- a. Miller Bearings; 1525 Capital Circle Nw # 5 Tallahassee, FL 32303

- b. Metal Fabrication and Sales; 3600 Weems Rd Ste D Tallahassee, FL 32317.
- c. www.radioshack.com
- d. www.mcmaster.com
- e. www.homedepot.com
- f. www.encoder-technology.com
- g. www.semiconductoronline.com/storefronts/thomsonindustries.html
- h. www.fremontindustrialsupply.com
- i. www.digikey.com
- j. www.laboratorydevicesco.com/index.html
- k. www.fouraker.com
- l. www.electromechanicsonline.com/products/ELMATU067040.asp

4.) Group Contacts –

- a. Greg Kostrzewsky - Cummins Contact/Sponsor
- b. Kevin Garvey - Sponsor Contact and provided data acquisition program (Lab View)
- c. Yu Zheng - Assisted with electrical components
- d. Chris Monzingo - Assisted in electrical component selection
- e. COE Machine Shop:
 - i. Tim Gamble, Supervisor - machinist and supplied parts
 - ii. Ed Hill- machinist
 - iii. Scott Goodman - machinist
 - iv. Keith Larson - supplied parts
 - v. Chip Young – machining advice
- f. Dr. Cesar Luongo, Professor of Mechanical Engineering
- g. Jon Cloos - Group Finances